



Operation **Manual**

Goodrive300-02 Series Through-the-Wall Inverter



Preface

Thanks for choosing Goodrive300-02 inverters.

Goodrive300-02 high performance open loop vector inverters can be used to control asynchronous AC induction motors and PMS motors. The products adopt world-leading synchronous speed sensorless vector control technology, use DSP control system and enhance the reliability, adaptability and customized and industry-oriented design, so the functions are optimized, the applications are more flexible and the performance is more stable.

Based on the hardware platform of Goodrive300 inverters, Goodrive300-02 series through-the-wall inverters are high performance vector inverters developed for avoiding cotton fiber, dust and oil causing secondary pollution, improving the reliability and adaptability. By the design of large radiator size and wide teeth space as well as through-the-wall installation manner, Goodrive300-02 inverters separate the cooling system and electrical system relatively, get the radiator fit outside the electric cabinet and reduce the temperature of the inverter via the external air duct of the radiator.

With the same excellent control performance as international high-end inverters, Goodrive300-02 inverters realize the integration of synchronous and asynchronous motor drives, torque control and speed control, so the products become the rare integrated drives in the industry and meet the requirements of high performance applications. Simultaneously, Goodrive300-02 inverters have the anti-trip performance beyond other products in the same category and the adaptability to harsh grid, temperature, humidity and dust, greatly improving the reliability.

Goodrive300-02 inverters adopt modular design. On the premise of meeting general requirements, the inverters can flexibly satisfy individual and industrial needs by extension design, which adapts to the application trends. The speed control, torque control, simple PLC, I/O terminals, pulse frequency reference and frequency control can meet the requirements of various complicated high accuracy drives and also provide high integrated solutions for equipment manufacturers, which are of great value for the system to reduce the cost and improve the reliability.

By EMC overall design, Goodrive300-02 inverters meet the environmental demand of low noise and electromagnetic interference.

This manual provides installation and configuration, parameters setting, fault diagnoses and daily maintenance and relative precautions for customers. Please read this manual carefully before the installation to ensure a proper installation and operation and high performance of Goodrive300-02 inverters.

If the product is ultimately used for military affairs or manufacture of weapon, it will be listed on the export control formulated by *Foreign Trade Law of the People's Republic of China*. Rigorous review and necessary export formalities are needed when exported.

Our company reserves the right to update the information of our products.

Content

Preface	1
Content	2
Safety precautions	1 5
1.1 What this chapter contains	5
1.2 Safety definition	5
1.3 Warning symbols	5
1.4 Safety guidelines	6
Quick start-up	2 9
2.1 What this chapter contains	9
2.2 Unpacking inspection	9
2.3 Application confirmation	9
2.4 Environment confirmation	9
2.5 Installation confirmation	10
2.6 Basic commissioning	11
Product overview	3 12
3.1 What this chapter contains	12
3.2 Basic principles	12
3.3 Product specification	13
3.4 Name plate	15
3.5 Type designation key	15
3.6 Rated specifications for the inverters of AC 3PH 380V(-15%)~440V(+10%)	16
3.7 Structure diagram	16
Installation guidelines	4 18
4.1 What this chapter contains	18
4.2 Mechanical installation	18
4.3 Standard wiring	21
4.4 Layout protection	27
Keypad operation procedure	5 29
5.1 What this chapter contains	29
5.2 Keypad	29
5.3 Keypad displaying	31
5.4 Keypad operation	33
Function parameters	6 35

6.1 What this chapter contains	35
6.2 List of function parameters	35
Basic operation instruction	7
7.1 What this chapter contains	127
7.2 First powering on	127
7.3 Vector control	132
7.4 SVPWM control	137
7.5 Torque control	143
7.6 Parameters of the motor	147
7.7 Start-up and stop control	153
7.8 Frequency setting	157
7.9 Analog input	162
7.10 Analog output	164
7.11 Digital input	167
7.12 Digital output	175
7.13 Simple PLC	179
7.14 Multi-step speed running	182
7.15 PID control	184
7.16 Traverse running	188
7.17 Pulse counter	190
7.18 Fixed-length control	191
7.19 Fault handling	192
Fault tracking	8
8.1 What this chapter contains	196
8.2 Alarm and fault indications	196
8.3 Fault reset	196
8.4 Fault history	196
8.5 Fault instruction and solution	196
8.6 Common fault analysis	202
Maintenance and hardware diagnosis	9
9.1 What this chapter contains	208
9.2 Maintenance intervals	208
9.3 Cooling fan	210
9.4 Capacitors	211
9.5 Power cable	212

Communication protocol	10	213
10.1 What this chapter contains		213
10.2 Brief introduction to MODBUS protocol		213
10.3 Application of the inverter		213
10.4 RTU command code and communication data illustration		219
10.5 Common communication fault		234
Extension card	Appendix A	235
A.1 What this chapter contains		235
A.2 PROFIBUS extension card		235
A.3 CANopen optional cards		251
Technical data	Appendix B	252
B.1 What this chapter contains		252
B.2 Ratings		252
B.3 Grid specifications		253
B.4 Motor connection data		253
B.5 Applicable standards		254
B.6 EMC regulations		255
Dimension drawings	Appendix C	257
C.1 What this chapter contains		257
C.2 Overall dimension		257
C.3 Installation dimension		258
Peripheral options and parts	Appendix D	259
D.1 What this chapter contains		259
D.2 Peripheral wiring		259
D.3 Power supply		260
D.4 Cables		261
D.5 Breaker and electromagnetic contactor		264
D.6 Reactors		264
D.7 Filters		266
D.8 Braking system		267
Further information	Appendix E	270

Safety precautions

1

1.1 What this chapter contains

Please read this manual carefully and follow all safety precautions before moving, installing, operating and servicing the inverter. If ignored, physical injury or death may occur, or damage may occur to the devices.









If any physical injury or death or damage to the devices occurs for ignoring to the safety precautions in the manual, our company will not be responsible for any damages and we are not legally bound in any manner.

1.2 Safety definition

Danger:	Serious physical injury or even death may occur if not follow relevant requirements
Warning:	Physical injury or damage to the devices may occur if not follow relevant requirements
Note:	Physical hurt may occur if not follow relevant requirements
Qualified electricians:	People working on the device should take part in professional electrical and safety training, receive the certification and be familiar with all steps and requirements of installing, commissioning, operating and maintaining the device to avoid any emergency.





1.3 Warning symbols

Warnings caution you about conditions which can result in serious injury or death and/or damage to the equipment, and advice on how to avoid the danger. Following warning symbols are used in this manual:

Symbols	Name	Instruction	Abbreviation
 Danger	Electrical Danger	Serious physical injury or even death may occur if not follow the relative requirements	
 Warning	General danger	Physical injury or damage to the devices may occur if not follow the relative requirements	
 Do not	Electrostatic discharge	Damage to the PCBA board may occur if not follow the relative requirements	
 Hot sides	Hot sides	Sides of the device may become hot. Do not touch.	

Note	Note	Physical hurt may occur if not follow the relative requirements	Note
------	------	---	------

1.4 Safety guidelines

	<p>◇ Only qualified electricians are allowed to operate the inverter.</p> <p>◇ Do not carry out any wiring and inspection or changing components when the power supply is applied. Ensure all input power supply is disconnected before wiring and checking and always wait for at least the time designated on the inverter or until the DC bus voltage is less than 36V. Below is the table of the waiting time:</p> <table border="1" style="margin-left: auto; margin-right: auto;"> <thead> <tr> <th colspan="2">Inverter module</th> <th>Min. waiting time</th> </tr> </thead> <tbody> <tr> <td style="text-align: center;">380V</td> <td style="text-align: center;">7.5kW-55kW</td> <td style="text-align: center;">5 minutes</td> </tr> </tbody> </table>	Inverter module		Min. waiting time	380V	7.5kW-55kW	5 minutes
Inverter module		Min. waiting time					
380V	7.5kW-55kW	5 minutes					
	<p>◇ Do not refit the inverter unauthorizedly; otherwise fire, electric shock or other injury may occur.</p>						
	<p>◇ The base of the radiator may become hot during running. Do not touch to avoid hurt.</p>						
	<p>◇ The electrical parts and components inside the inverter are electrostatic. Take measurements to avoid electrostatic discharge during relevant operation.</p>						

1.4.1 Delivery and installation

	<p>◇ Please install the inverter on fire-retardant material and keep the inverter away from combustible materials.</p> <p>◇ Connect the braking optional parts (braking resistors, braking units or feedback units) according to the wiring diagram.</p> <p>◇ Do not operate the inverter if there is any damage or components loss to the inverter.</p> <p>◇ Do not touch the inverter with wet items or body, otherwise electric shock may occur.</p>
--	---

Note:

- ◇ Select appropriate moving and installing tools to ensure a safe and normal running of the inverter and avoid physical injury or death. For physical safety, the erector should take some mechanical protective measurements, such as wearing smash-proof shoes and working uniforms.
- ◇ Ensure to avoid physical shock or vibration during delivery and installation.
- ◇ Do not carry the inverter by its cover. The cover may fall off.
- ◇ Install away from children and other public places.

- ◇ The inverter cannot meet the requirements of medium and low voltage protection in IEC61800-5-1 if the sea level of installation site is above 2000m.
- ◇ Please use the inverter on appropriate condition (See chapter *Installation environment*).
- ◇ Do not allow screws, cables or other conductive items to fall inside the inverter.
- ◇ The leakage current of the inverter may be above 3.5mA during operation. Ground with proper techniques and ensure the grounding resistor is less than 10Ω . The conductivity of PE grounding conductor is the same as that of the phase conductor (with the same cross sectional area).
- ◇ R, S and T are the input terminals of the power supply, while U, V and W are the output terminals of the motor. Please connect the input power cables and motor cables with proper techniques; otherwise the damage to the inverter may occur.

1.4.2 Commissioning and running

	<ul style="list-style-type: none"> ◇ Disconnect all power supplies applied to the inverter before the terminal wiring and wait for at least the designated time on the inverter after disconnecting the power supply. ◇ High voltage is present inside the inverter during running. Do not carry out any operation except for the keypad setting. ◇ The inverter may start up by itself when P01.21=1. Do not get close to the inverter and motor. ◇ The inverter cannot be used as “Emergency-stop device”. ◇ The inverter cannot be used to break the motor suddenly. A mechanical braking device should be provided. ◇ When the PMS motor is running, except above precautions before installation and maintenance, confirm as followings: <ol style="list-style-type: none"> 1. All input power supplies including main power and control power are disconnected. 2. The PMS motor stops running and the voltage at the output side of the inverter is less than 36V. 3. The waiting time is not lower than the designated time on the inverter after PMS motor stops running and the voltage between + and - is less than 36V. 4. During operation, ensure it is impossible for PMS motor to run again due to external loads. Suggest installing effective external braking devices or disconnecting the electrical connection between PMS motor and the inverter.
--	--

Note:

- ◇ Do not switch on or off the input power supply of the inverter frequently.

- ◇ For inverters that have been stored for a long time, check and fix the capacitance and try to run it again before utilization (see *Maintenance and hardware fault diagnosis*).
- ◇ Cover the front board before running, otherwise electric shock may occur.

1.4.3 Maintenance and replacement of components

	<ul style="list-style-type: none"> ◇ Only qualified electricians are allowed to perform the maintenance, inspection, and components replacement of the inverter. ◇ Disconnect all power supplies to the inverter before the terminal wiring. Wait for at least the time designated on the inverter after disconnection. ◇ Take measures to avoid screws, cables or other conductive items to fall into the inverter during maintenance and component replacement.
---	--

Note:

- ◇ Please select proper torque to tighten screws.
- ◇ Keep the inverter and components away from combustible materials during maintenance and component replacement.
- ◇ Do not carry out any isolation and pressure test on the inverter and do not measure the control circuit of the inverter by megameter.
- ◇ Carry out a sound anti-electrostatic protection to the inverter and its internal components during maintenance and component replacement.

1.4.4 What to do after scrapping

	<ul style="list-style-type: none"> ◇ There are heavy metals in the inverter. Deal with it as industrial effluent.
---	--

Quick start-up

2

2.1 What this chapter contains

This chapter mainly describes the basic guidelines during the installation and commission procedures on the inverter, which you may follow to install and commission the inverter quickly.

2.2 Unpacking inspection

Check as followings after receiving products:

- | |
|---|
| 1. Check that there are no damage and humidification to the package. If not, please contact with local agents or company offices. |
| 2. Check the information on the type designation label on the outside of the package to verify that the drive is the correct type. If not, please contact with local dealers or company offices. |
| 3. Check that there are no signs of water in the package and no signs of damage or breach to the inverter. If not, please contact with local dealers or company offices. |
| 4. Check the information on the type designation label on the outside of the package to verify that the name plate is the correct type. If not, please contact with local dealers or company offices. |
| 5. Check to ensure the accessories (including user's manual, control keypad and extension card) inside the device are complete. If not, please contact with local dealers or company offices. |

2.3 Application confirmation

Check the machine before beginning to use the inverter:

- | |
|---|
| 1. Check the load type to verify that there is no overload of the inverter during work and check that whether the drive needs to modify the power degree. |
| 2. Check that the actual current of the motor is less than the rated current of the inverter. |
| 3. Check that the control accuracy of the load is the same of the inverter. |
| 4. Check that the grid voltage is consistent with the rated voltage of the inverter. |
| 5. Check that the communication needs optional card or not. |

2.4 Environment confirmation

Check as followings before the actual installation and usage:

- | |
|--|
| 1. Check that the ambient temperature of the inverter is below 40°C. If exceeds, derate 3% for every additional 1°C. Additionally, the inverter cannot be used if the ambient temperature is above 50°C.

Note: For the cabinet inverter, the ambient temperature means the air temperature inside the cabinet. |
|--|

<p>2. Check that the ambient temperature of the inverter in actual usage is above -10°C. If not, add heating facilities.</p> <p>Note: For the cabinet inverter, the ambient temperature means the air temperature inside the cabinet.</p>
<p>3. Check that the altitude of the actual usage site is below 1000m. If exceeds, derate 1% for every additional 100m.</p>
<p>4. Check that the humidity of the actual usage site is below 90% and condensation is not allowed. If not, add additional protection inverters.</p>
<p>5. Check that the actual usage site is away from direct sunlight and foreign objects can not enter the inverter. If not, add additional protective measures.</p>
<p>6. Check that there is no conductive dust or flammable gas in the actual usage site. If not, add additional protection to inverters.</p>

2.5 Installation confirmation

Check as followings after the installation:

<p>1. Check that the load range of the input power cables and motor cables meet the need of actual load.</p>
<p>2. Check that the accessories of the inverter are correctly and properly installed. The installation cables should meet the needs of every component (including reactors, input filters, output reactors, output filters, DC reactors, braking units and braking resistors).</p>
<p>3. Check that the inverter is installed on non-flammable materials and the calorific accessories (reactors and brake resistors) are away from flammable materials.</p>
<p>4. Check that all control cables and power cables run separately and the routing complies with EMC requirement.</p>
<p>5. Check that all grounding systems are properly grounded according to the requirements of the inverter.</p>
<p>6. Check that the free space during installation is sufficient according to the instructions in user's manual.</p>
<p>7. Check that the installation conforms to the instructions in user's manual. The drive must be installed in an upright position.</p>
<p>8. Check that the external connection terminals are tightly fastened and the torque is appropriate.</p>
<p>9. Check that there are no screws, cables and other conductive items left in the inverter. If not, get them out.</p>

2.6 Basic commissioning

Complete the basic commissioning as followings before actual utilization:

- | |
|---|
| 1. Select the motor type, set correct motor parameters and select control mode of the inverter according to the actual motor parameters. |
| 2. Autotuning. If possible, de-coupled from the motor load to start dynamic autotuning. Or if not, static autotuning is available. |
| 3. Adjust the ACC/DEC time according to the actual running of the load. |
| 4. Commission the device via jogging and check that the rotation direction is as required. If not, change the rotation direction by changing the wiring of motor. |
| 5. Set all control parameters and then operate. |

Product overview

3.1 What this chapter contains

The chapter briefly describes the operation principle, product characteristics, layout, name plate and type designation information.

3.2 Basic principles

Goodrive300-02 inverters are through-the-wall mounting devices for controlling asynchronous AC induction motors and PMS motors.

The diagram below shows the simplified main circuit diagram of the inverter. The rectifier converts three-phase AC voltage to DC voltage. The capacitor bank of the intermediate circuit stabilizes the DC voltage. The converter transforms the DC voltage back to AC voltage for the AC motor. The brake pipe connects the external braking resistor to the intermediate DC circuit to consume the feedback energy when the voltage in the circuit exceeds its maximum limit.

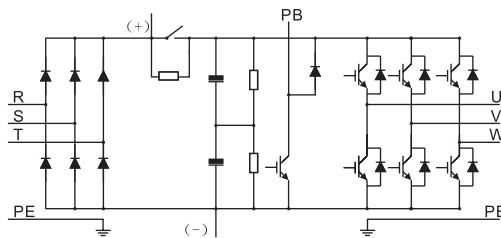

Fig 3-1 The simplified main circuit diagram (inverters of 380V ≤30kW)

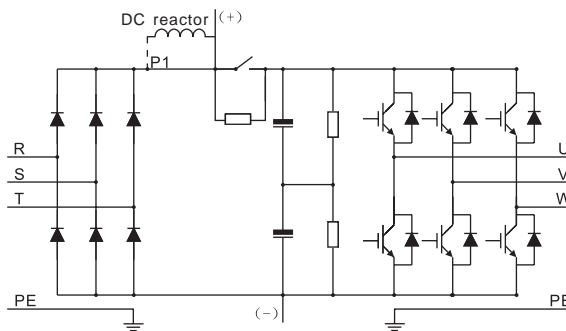

Fig 3-2 The simplified main circuit diagram (inverters of 380V ≥37kW)

Note:

1. The inverters of 380V ($\geq 37\text{kW}$) supports external DC reactors, but it is necessary to remove the copper tag between P1 and (+) before connecting. The inverters of 380V ($\geq 22\text{kW}$) supports external braking units. DC reactors and braking units are optional.
2. The inverters of 380V ($\leq 18.5\text{kW}$) supports external braking resistors which are optional.

3.3 Product specification

Function		Specification
Power input	Input voltage (V)	AC 3PH 380V(-15%)~440V(+10%) Rated voltage: 380V
	Input current (A)	Refer to <i>the rated value</i>
	Input frequency (Hz)	50Hz or 60Hz Allowed range: 47~63Hz
Power output	Output voltage (V)	0~input voltage
	Output current (A)	Refer to <i>the rated value</i>
	Output power (kW)	Refer to <i>the rated value</i>
	Output frequency (Hz)	0~400Hz
Technical control feature	Control mode	SVPWM, SVC
	Motor type	Asynchronous motor, PMS motor
	Adjustable-speed ratio	Asynchronous motor 1:200 (SVC), synchronous motor 1:20 (SVC)
	Speed control accuracy	$\pm 0.2\%$ (SVC)
	Speed fluctuation	$\pm 0.3\%$ (SVC)
	Torque response	<20ms (SVC)
	Torque control accuracy	10% (SVC)
	Starting torque	Asynchronous motor: 0.25Hz/150% (SVC) Synchronous motor: 2.5Hz/150% (SVC)
	Overload capability	150% of rated current: 1 minute 180% of rated current: 10 seconds 200% of rated current: 1 second
Running control feature	Frequency setting method	Digital setting, analog setting, pulse frequency setting, multi-step speed running setting, simple PLC setting, PID setting, MODBUS communication setting,

Function		Specification
		PROFIBUS communication setting, etc. Switch between the combination and the set channel.
	Auto-adjustment of the voltage	Keep constant voltage automatically when the grid voltage transients
	Fault protection	Provide more than 30 fault protection functions: overcurrent, overvoltage, undervoltage, overheating, phase loss and overload, etc.
	Restart after rotating speed tracking	Smooth starting of the rotating motor
Peripheral interface	Terminal analog input resolution	≤ 20mV
	Terminal switch input resolution	≤ 2ms
	Analog input	2 (AI1, AI2) 0~10V/0~20mA and 1 (AI3) -10~10V
	Analog output	2 (AO1, AO2) 0~10V/0~20mA
	Digital input	8 common inputs, the Max. frequency: 1kHz, internal impedance: 3.3kΩ; 1 high-speed input, the Max. frequency: 50kHz
	Digital output	1 high-speed pulse output, the Max. frequency: 50kHz; 1 Y terminal open collector output
	Relay output	2 programmable relay outputs RO1A NO, RO1B NC, RO1C common terminal RO2A NO, RO2B NC, RO2C common terminal Contact capacity: 3A/AC250V, 1A/DC30V
Others	Mountable method	Through-the-wall (flange) mounting
	Temperature of the running environment	-10~50°C, derate above 40°C
	Average non-fault time	2 years (25°C ambient temperature)
	Protective degree	IP20
	Cooling	Forced air cooling (external air duct cooling, air speed>2m/s)
	Braking unit	Built-in for inverters (≤18.5kW) Optional and external for inverters (≥22kW)

Function		Specification
	EMC filter	Built-in C3 filter: meet the degree requirement of IEC61800-3 C3 Optional and external filter: meet the degree requirement of IEC61800-3 C2

3.4 Name plate

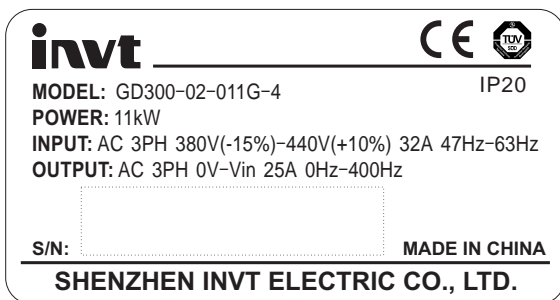

Note: The name plate above is an example of Goodrive300-02 standard products. CE/TUV/IP20 will be identified on basis of actual certification.

Fig 3-3 Name plate

3.5 Type designation key

The type designation contains information on the inverter. The user can find the type designation on the type designation label attached to the inverter or the simple name plate.

GD300-02 - 022G - 4
①
②
③

Fig 3-4 Product model

Key	No.	Detailed description	Detailed content
Abbreviation	①	Product abbreviation	Goodrive300-02: through-the-wall inverter GD300-02 is short for Goodrive300-02.
Rated power	②	Power range + Load type	022-22kW G-Constant torque load
Voltage degree	③	Voltage degree	4: AC 3PH 380V(-15%)~440V(+10%) Rated voltage: 380V

3.6 Rated specifications for the inverters of AC 3PH 380V(-15%)~440V(+10%)

Model	Output power (kW)	Input current (A)	Output current (A)	Carrier frequency (kHz)
GD300-02-7R5G-4	7.5	25	18.5	1~15 (8)
GD300-02-011G-4	11	32	25	1~15 (8)
GD300-02-015G-4	15	40	32	1~15 (4)
GD300-02-018G-4	18.5	47	38	1~15 (4)
GD300-02-022G-4	22	56	45	1~15 (4)
GD300-02-030G-4	30	70	60	1~15 (4)
GD300-02-037G-4	37	80	75	1~15 (4)
GD300-02-045G-4	45	94	92	1~15 (4)
GD300-02-055G-4	55	128	115	1~15 (4)

Note:

1. The input current of inverters 7.5~55kW is detected when the input voltage is 380V and there is no DC reactors and input/output reactors.
2. The output current cannot exceed the rated output current and the output power cannot exceed the rated output power in the voltage range.

3.7 Structure diagram

Below is the layout figure of the inverter (take the inverter of 380V 18.5kW as the example).

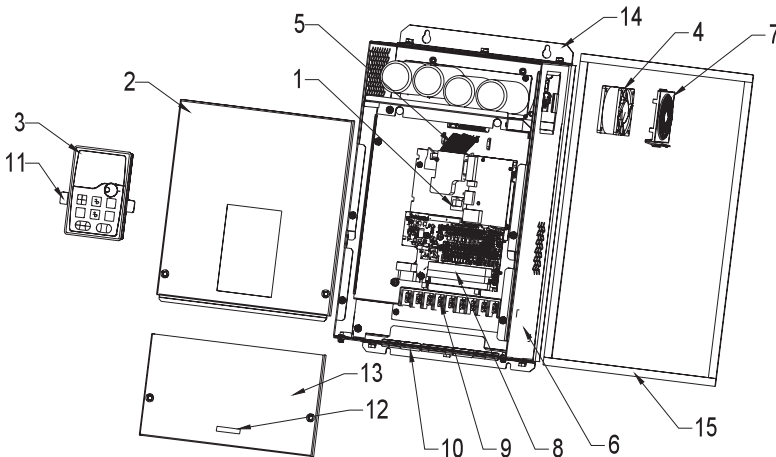



Fig 3-5 Product structure

Serial No.	Name	Illustration
1	Keypad port	Connect the keypad
2	Upper cover	Protect the internal parts and components
3	Keypad	See Keypad operation procedure for detailed information
4	Cooling fan	See Maintenance and hardware fault diagnosis for detailed information
5	Wiring port	Connect to the control board and the drive board
6	Name plate	See Operation principle and product overview for detailed information
7	Fan cover	Protect the fans
8	Control terminals	See Electric installation for detailed information
9	Main circuit terminals	See Electric installation for detailed information
10	Main circuit cable port	Fix the main circuit cable
11	Fixed strip of keypad	Fix the keypad
12	Simple name plate	See Model codes for detailed information
13	Lower cover	Protect the internal parts and components
14	Upper and lower mounting support	Fix the inverter
15	EPDM foaming rubber strip	Seal the inverter and belong to accessories. Users can paste it for sealing on their own.

Installation guidelines

4.1 What this chapter contains

The chapter describes the mechanical installation and electric installation.

	<ul style="list-style-type: none"> ◇ Only qualified electricians are allowed to carry out what described in this chapter. Please operate as the instructions in Safety precautions. Ignoring these may cause physical injury or death or damage to the devices. ◇ Ensure the power supply of the inverter is disconnected during the operation. Wait for at least the time designated until the POWER indicator is off after the disconnection if the power supply is applied. It is recommended to use the multimeter to monitor that the DC bus voltage of the drive is under 36V. ◇ The installation and design of the inverter should comply with the requirement of the local laws and regulations in the installation site. If the installation infringes the requirement, our company will exempt from any responsibility. Additionally, if users do not comply with the suggestions, some damage beyond the assured maintenance range may occur.
---	--

4.2 Mechanical installation

4.2.1 Installation environment

The installation environment is the safeguard for a full performance and long-term stable functions of the inverter. Check the installation environment as followings:

Environment	Conditions
Installation site	Indoor
Environment temperature	<p>-10~+50°C</p> <p>If the ambient temperature of the inverter is above 40°C, derate 3% for every additional 1°C.</p> <p>It is not recommended to use the inverter if the ambient temperature is above 50°C.</p> <p>Note: Ensure the air speed of the radiator is above 2m/s.</p> <p>In order to improve the reliability of the device, do not use the inverter if the ambient temperature changes frequently.</p> <p>Please provide cooling fan or air conditioner to control the internal ambient temperature below the required one if the inverter is used in a close space such as in the control cabinet.</p> <p>When the temperature is too low, if the inverter needs to restart to run after a long stop, it is necessary to provide an external heating device</p>

Environment	Conditions
	to increase the internal temperature, otherwise damage to the devices may occur.
Humidity	RH<90% No condensation is allowed. The maximum relative humidity should be equal to or less than 60% in corrosive air.
Storage temperature	-30~+60°C
Running environment condition	The installation site of the inverter should: keep away from the electromagnetic radiation source; keep away from oil mist, corrosive gas and flammable gas; ensure foreign objects, such as metal power, dust, oil and water cannot enter into the inverter (do not install the inverter on the flammable materials such as wood); keep away from radioactive and flammable materials; keep away from harmful gas and liquid; be in sites with little salt; keep away from direct sunlight.
Altitude	<1000m If the sea level is above 1000m, please derate 1% for every additional 100m.
Vibration	$\leq 5.8\text{m/s}^2(0.6\text{g})$
Installation direction	The inverter should be installed on an upright position to ensure sufficient cooling effect.

4.2.2 Installation direction

The inverter may be installed on the wall or in a cabinet.

The inverter must be installed in an upright position. Check the installation site according to the requirements below. Refer to chapter *Dimension drawings* in the appendix for frame details.

4.2.3 Installation manner

Through-the-wall (flange) mounting (for the inverters of $380V \leq 55kW$)

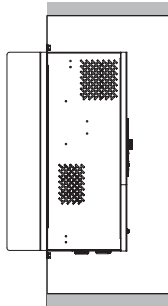

Fig 4-2 Installation manner

- (1) Mark the hole location. The location of the holes is shown in the dimension drawings in the appendix.
- (2) To ensure sealing without gap, paste the EPDM foaming rubber strip onto the inverter or installation board.
- (3) Put the inverter through the wall.
- (4) Fix the screws or bolts to the marked locations and tighten the mounting screws in the wall.
- (5) External independent air duct, air speed > 2m/s.

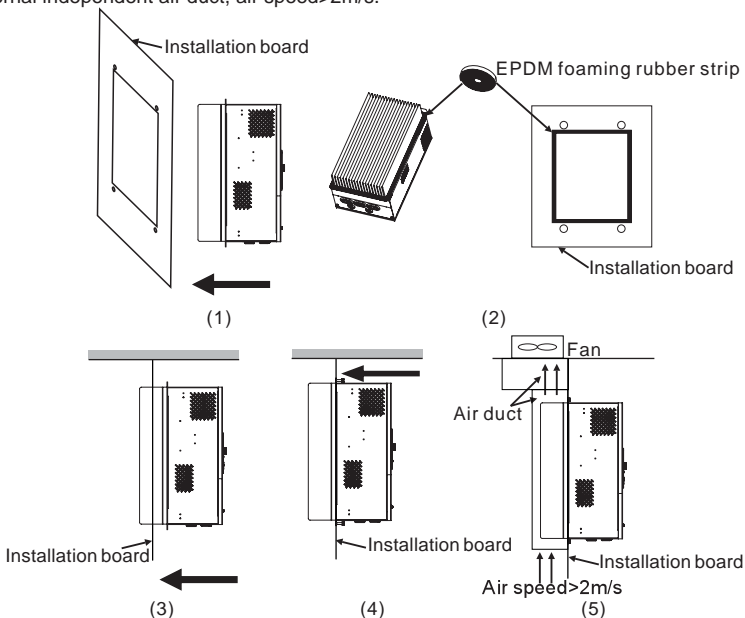

Fig 4-3 Installation diagram

4.3 Standard wiring

4.3.1 Wiring of main circuit

4.3.1.1 Wiring of main circuit for the inverters of AC 3PH 380V(-15%)~440V(+10%)

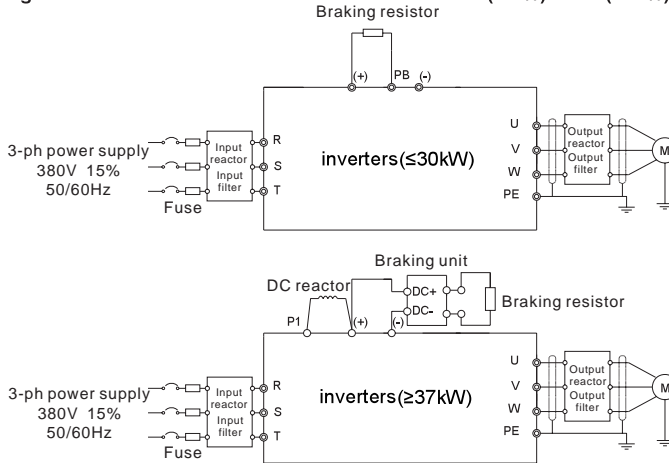

Fig 4-4 Wiring of main circuit for the inverters of 380V

Note:

1. The fuse, DC reactor, braking unit, braking resistor, input reactor, input filter, output reactor, output filter are optional parts. Please refer to *Peripheral Optional Parts* for detailed information.
2. P1 and (+) are short circuited in factory for the inverters of 380V ($\geq 37kW$), if need to connect with the DC reactor, please remove the contact tag between P1 and (+).

The inverters of 22~30kW need to connect with external braking units.

4.3.2 Terminals of main circuit

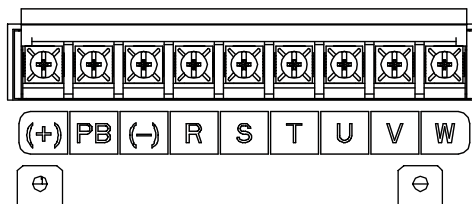

Fig 4-5 Terminals of main circuit for the inverters of 380V 7.5~18kW

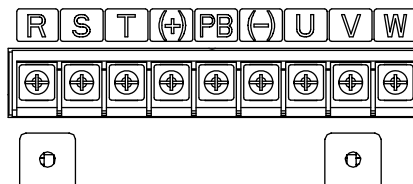

Fig 4-6 Terminals of main circuit for the inverters of 380V 22~30kW

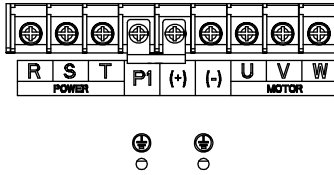

Fig 4-7 Terminals of main circuit for the inverters of 380V 37~55kW

Terminal	Terminal name		Function
	380V ≤30kW	380V ≥37kW	
R,S,T	Power input of the main circuit		3-phase AC input terminals which are generally connected with the power supply.
U,V,W	The inverter output		3-phase AC output terminals which are generally connected with the motor.
P1	/	DC reactor terminal 1	P1 and (+) are connected with the terminals of DC reactor.
(+)	Braking resistor 1	DC reactor terminal 2, braking unit terminal 1	
(-)	/	Braking unit terminal 2	(+) and (-) are connected with the terminals of braking unit.
PB	Braking resistor 2	/	PB and (+) are connected with the terminals of braking resistor.
PE	380V: the grounding resistor is less than 10Ω		Protective grounding terminals, every machine is provided 2 PE terminals as the standard configuration. These terminals should be grounded reliably.

Note:

- ◆ Do not use an asymmetrically constructed motor cable. If there is a symmetrically constructed grounding conductor in the motor cable in addition to the conductive shield, connect the grounding conductor to the grounding terminal at the inverter and motor ends.
- ◆ Braking resistor, braking unit and DC reactor are optional parts.
- ◆ Route the motor cable, input power cable and control cables separately.
- ◆ If the terminal description is “/”, the machine does not provide the terminal as the external terminal.

4.3.3 Wiring of terminals in main circuit

1. Fasten the grounding conductor of the input power cable with the grounding terminal of the inverter (PE) by 360 degree grounding technique. Connect the phase conductors to R, S and T terminals and

fasten.

2. Strip the motor cable and connect the shield to the grounding terminal of the inverter by 360 degree grounding technique. Connect the phase conductors to U, V and W terminals and fasten.
3. Connect the optional brake resistor with a shielded cable to the designated position by the same procedures in the previous step.
4. Secure the cables outside the inverter mechanically.

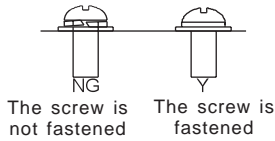

Fig 4-8 Correct installation of the screw

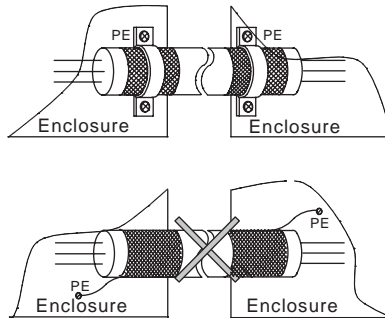

Fig 4-9 360 degree grounding technique

4.3.4 Wiring of control circuit

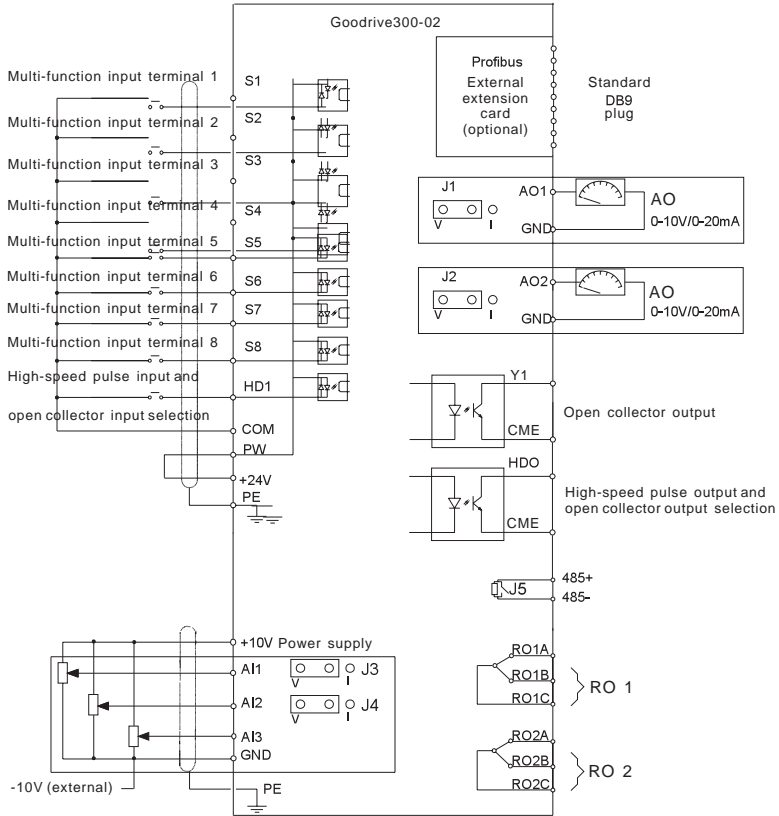

Fig 4-10 Wiring of control circuit

4.3.5 Terminals of control circuit

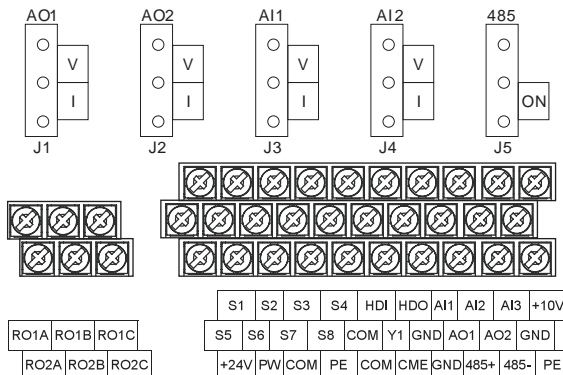
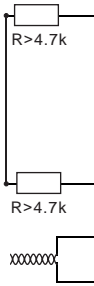
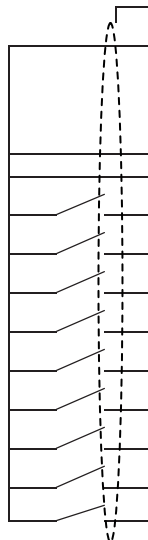

Fig 4-11 Terminals of control circuit

Terminal name	Description
RO1A	RO1 relay output, RO1A NO, RO1B NC, RO1C common terminal Contact capacity: 3A/AC250V, 1A/DC30V
RO1B	
RO1C	
RO2A	RO2 relay output, RO2A NO, RO2B NC, RO2C common terminal Contact capacity: 3A/AC250V, 1A/DC30V
RO2B	
RO2C	



Terminal name	Description
HDO	1. Switch capacity: 200mA/30V 2. Output frequency range: 0~50kHz
COM	+24V common terminal
CME	Common terminal of open collector output
Y	1. Switch capacity: 200mA/30V 2. Output frequency range: 0~1kHz
485+	485 communication interface and 485 differential signal interface If it is the standard 485 communication interface, please use twisted pairs or shield cable.
485-	



Terminal name	Description
PE	Grounding terminal
PW	Provide the input switch working power supply from external to internal. Voltage range: 12~24V
24V	The inverter provides the power supply for users with a maximum output current of 200mA
COM	+24V common terminal
S1	Switch input 1
S2	Switch input 2
S3	Switch input 3
S4	Switch input 4
S5	Switch input 5
S6	Switch input 6
S7	Switch input 7
S8	Switch input 8
HDI	Except for S1~S8, the terminal can be used as high frequency input

channel. Max. input frequency: 50kHz	
Terminal name	Description
+10V	Local power supply +10V
AI1	1. Input range: AI1/AI2 voltage and current can be chosen: 0~10V/0~20mA; AI1 can be shifted by J3, AI2 can be shifted by J4. AI3: -10V~+10V 2. Input impedance: voltage input: 20kΩ, current input: 500Ω 4. Resolution: the minimum one is 5mV when 10V corresponds to 50Hz 5. Deviation±1%, 25°C
AI2	
AI3	
GND	+10V reference null potential
AO1	1. Output range: 0~10V or 0~20mA; voltage or current output is set by jumpers; AO1 can be shifted by J1, AO2 can be shifted by J2. 2. Deviation±1%, 25°C
AO2	

4.3.6 Input/output signal connection figure

Please use U-shaped contact tag to set NPN mode or PNP mode and the internal or external power supply. The default setting is NPN internal mode.

Screw torque of control board for Goodrive300-02 series inverters: 3.5 ibf in

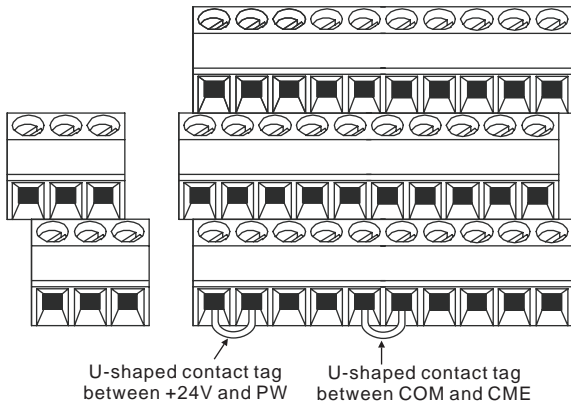

Fig 4-12 U-shaped contact tag

If the signal is from NPN transistor, please set the U-shaped contact tag between +24V and PW as below according to the used power supply.

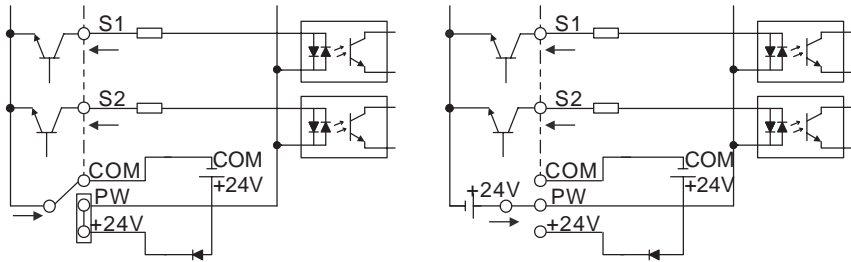

Fig 4-13 NPN modes

If the signal is from PNP transistor, please set the U-shaped contact tag as below according to the used power supply.

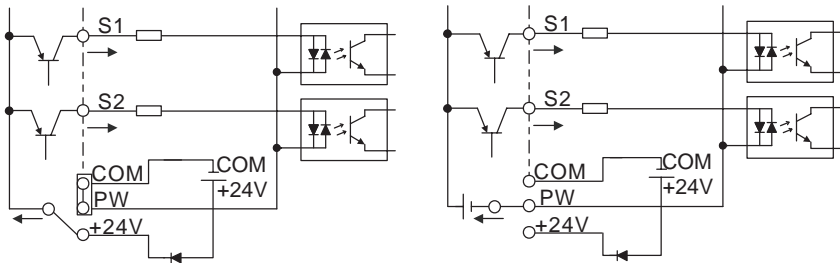

Fig 4-14 PNP modes

4.4 Layout protection

4.4.1 Protecting the inverter and input power cable in short-circuit situations

Protect the inverter and input power cable in short circuit situations and against thermal overload
 Arrange the protection according to the following guidelines.

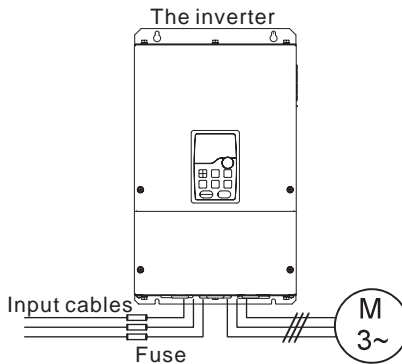

Fig 4-15 Fuse configuration

Note: Select the fuse as the manual indicated. The fuse will protect the input power cable from

damage in short-circuit situations. It will protect the surrounding devices when the internal of the inverter is short circuited.

4.4.2 Protecting the motor and motor cable in short-circuit situations

The inverter protects the motor and motor cable in a short-circuit situation when the motor cable is dimensioned according to the rated current of the inverter. No additional protection devices are needed.



⇨ If the inverter is connected to multiple motors, a separate thermal overload switch or a circuit breaker must be used for protecting each cable and motor. These devices may require a separate fuse to cut off the short-circuit current.

4.4.3 Protecting the motor against thermal overload

According to regulations, the motor must be protected against thermal overload and the current must be switched off when overload is detected. The inverter includes a motor thermal protection function that protects the motor and closes the output to switch off the current when necessary.

4.4.4 Implementing a bypass connection

It is necessary to set power frequency and variable frequency conversion circuits for the assurance of continuous normal work of the inverter if faults occur in some significant situations.

In some special situations, for example, if it is only used in soft start, the inverter can be converted into power frequency running after starting and some corresponding bypass should be added.



⇨ Never connect the power supply to the output terminals U, V and W of the inverter. Voltage applied to the motor cable may result in permanent damage to the inverter.

If frequent shifting is required, employ mechanically connected switches or contactors to ensure that the motor terminals are not connected to the input power cable and inverter output terminals simultaneously.

Keypad operation procedure

5.1 What this chapter contains

This chapter contains following operation:

- Buttons, indicating lights and the screen as well as the methods to inspect, modify and set function codes by keypad











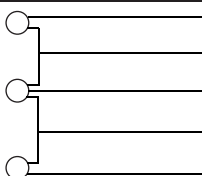



















5.2 Keypad







The keypad is used to control Goodrive300-02 inverters, read the state data and adjust parameters.



Fig 5-1 Keypad

No.	Name	Description	
1	State LED	RUN/TUNE	LED off means that the inverter is in the stopping state; LED blinking means the inverter is in the parameter autotune state; LED on means the inverter is in the running state.
		FWD/REV	FWD/REV LED LED off means the inverter is in the forward rotation state; LED on means the inverter is in the reverse rotation state.
		LOCAL/REMOT	LED for keypad operation, terminals operation and remote communication control LED off means that the inverter is in the keypad operation state; LED blinking means the inverter is in the terminals operation state; LED on means the inverter is in the remote communication

No.	Name	Description					
			control state.				
		TRIP	LED for faults LED on when the inverter is in the fault state; LED off in normal state; LED blinking means the inverter is in the pre-alarm state.				
2	Unit LED	Mean the unit displayed currently					
			Hz Frequency unit				
			RPM Rotating speed unit				
			A Current unit				
			% Percentage				
		V Voltage unit					
3	Code displaying zone	5-figure LED display displays various monitoring data and alarm code such as set frequency and output frequency.					
		Displayed	Corresponding word	Displayed word	Corresponding word	Displayed word	Corresponding word
			0		1		2
			3		4		5
			6		7		8
			9		A		B
			C		d		E
			F		H		
			L		N		n
			o		P		r
	S		t		U		
	v	.	.	'	-		
4	Digital potentiometer	Tuning frequency. Please refer to P08.42.					
5	Buttons		Programming key	Enter or escape from the first level menu and remove the parameter quickly			
			Entry key	Enter the menu step-by-step Confirm parameters			

No.	Name	Description	
		UP key	Increase data or function code progressively
		DOWN key	Decrease data or function code progressively
		Right-shift key	Move right to select the displaying parameter circularly in stopping and running mode. Select the parameter modifying digit during the parameter modification
		Run key	This key is used to operate the inverter in key operation mode
		Stop/Reset key	This key is used to stop in running state and it is limited by function code P07.04 This key is used to reset all control modes in the fault alarm state
		Quick key	The function of this key is confirmed by function code P07.02.



5.3 Keypad displaying

The keypad displaying state of Goodrive300-02 series inverters is divided into stopping state parameter, running state parameter, function code parameter editing state and fault alarm state and so on.

5.3.1 Displayed state of stopping parameter

When the inverter is in the stopping state, the keypad will display stopping parameters which is shown in figure 5-2.

In the stopping state, various kinds of parameters can be displayed. Select the parameters to be displayed or not by P07.07. See the instructions of P07.07 for the detailed definition of each bit.

In the stopping state, there are 14 stopping parameters can be selected to be displayed or not. They are: set frequency, bus voltage, input terminals state, output terminals state, PID reference, PID feedback, torque set value, AI1, AI2, AI3, HDI, PLC and the current step of multi-step speed, pulse count value, length value. P07.07 can select the parameter to be displayed or not by bit and /SHIFT can shift the parameters from left to right,  (P07.02=2) can shift the parameters from right to left.

5.3.2 Displayed state of running parameters

After the inverter receives valid running commands, the inverter will enter into the running state and the keypad will display the running parameters. **RUN/TUNE** LED on the keypad is on, while the **FWD/REV** is determined by the current running direction which is shown as figure 5-2.

In the running state, there are 24 parameters can be selected to be displayed or not. They are: running frequency, set frequency, bus voltage, output voltage, output current, running rotating speed, output power, output torque, PID reference, PID feedback, input terminals state, output terminals state, torque set value, length value, PLC and the current step of multi-step speed, AI1, AI2, AI3, HDI, percentage of motor overload, percentage of inverter overload, ramp reference value, linear speed, AC input current. P07.05 and P07.06 can select the parameter to be displayed or not by bit and **RIGHT/SHIFT** can shift the parameters from left to right, **QUICK/JOG** (P07.02=2) can shift the parameters from right to left.

5.3.3 Displayed state of fault

If the inverter detects the fault signal, it will enter into the fault alarm displaying state. The keypad will display the fault code by flickering. The **TRIP** LED on the keypad is on, and the fault reset can be operated by the **STOP/RST** on the keypad, control terminals or communication commands.

5.3.4 Displayed state of function codes editing

In the state of stopping, running or fault, press **PRG/ESC** to enter into the editing state (if there is a password, see P07.00).The editing state is displayed on two classes of menu, and the order is: function code group/function code number→function code parameter, press **DATA/ENT** into the displayed state of function parameter. On this state, you can press **DATA/ENT** to save the parameters or press **PRG/ESC** to retreat.

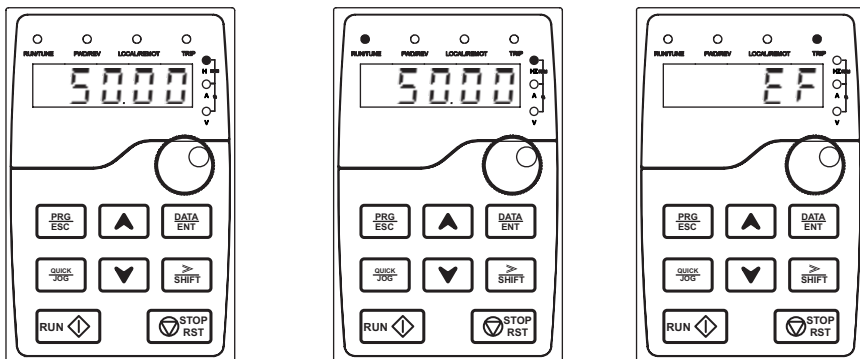

Fig 5-2 Displayed state

5.4 Keypad operation

Operate the inverter via operation panel. See the detailed structure description of function codes in the brief diagram of function codes.

5.4.1 How to modify the function codes of the inverter

The inverter has the menu of three levels, which are:

1. Group number of function code (first-level menu)
2. Tab of function code (second-level menu)
3. Set value of function code (third-level menu)

Remarks: Press both the **PRG/ESC** and the **DATA/ENT** can return to the second-level menu from the third-level menu. The difference is: pressing **DATA/ENT** will save the set parameters into the control panel, and then return to the second-level menu with shifting to the next function code automatically; while pressing **PRG/ESC** will directly return to the second-level menu without saving the parameters, and keep staying at the current function code.

Under the third-level menu, if the parameter has no flickering bit, it means the function code cannot be modified. The possible reasons could be:

- 1) This function code is not modifiable parameter, such as actual detected parameter, operation records and so on;
- 2) This function code is not modifiable in running state, but modifiable in stop state.

Example: Set function code P00.01 from 0 to 1.

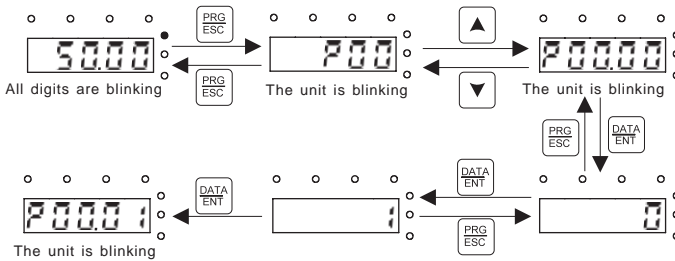

Fig 5-3 Sketch map of modifying parameters

5.4.2 How to set the password of the inverter

Goodrive300-02 series inverters provide password protection function to users. Set P07.00 to gain the password and the password protection becomes valid instantly after quitting from the function code editing state. Press **PRG/ESC** again to the function code editing state, "0.0.0.0.0" will be displayed. Unless using the correct password, the operators cannot enter it.

Set P07.00 to 0 to cancel password protection function.

The password protection becomes effective instantly after retreating from the function code editing

state. Press **PRG/ESC** again to the function code editing state, "0.0.0.0.0" will be displayed. Unless using the correct password, the operators cannot enter it.

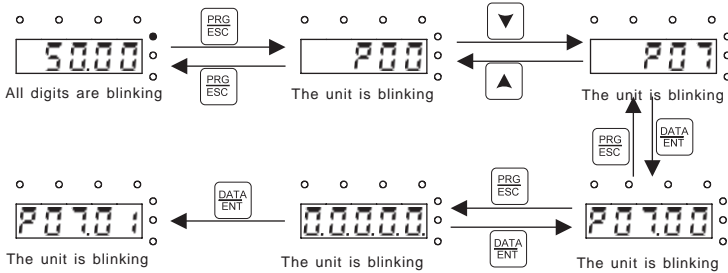

Fig 5-4 Sketch map of password setting

5.4.3 How to watch the inverter state through function codes

Goodrive300-02 series inverters provide group P17 as the state inspection group. Users can enter into P17 directly to watch the state.

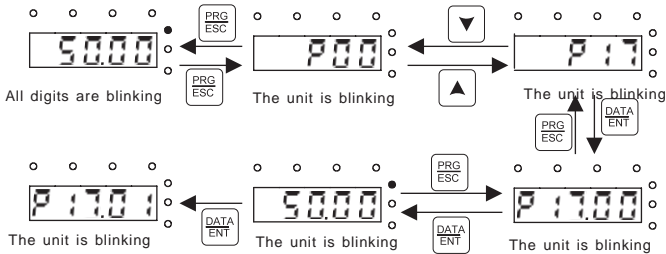

Fig 5-5 Sketch map of state watching

Function parameters

6

6.1 What this chapter contains

This chapter lists and describes the function parameters.

6.2 List of function parameters

The function parameters of Goodrive300-02 inverters have been divided into 30 groups (P00~P29) according to the function, of which P18~P28 are reserved. Each function group contains certain function codes applying 3-level menus. For example, "P08.08" means the eighth function code in the P8 group function, P29 group is factory reserved, and users are forbidden to access these parameters.

For the convenience of function codes setting, the function group number corresponds to the first level menu, the function code corresponds to the second level menu and the function code corresponds to the third level menu.

1. Below is the instruction of the function lists:

The first line "Function code": codes of function parameter group and parameters;

The second line "Name": full name of function parameters;

The third line "Detailed instruction of parameters": detailed instruction of the function parameters;

The fourth line "Default value": the original factory values of the function parameter;

The fifth line "Modify": the modifying character of function codes (the parameters can be modified or not and the modifying conditions), below is the instruction:

"○": means the set value of the parameter can be modified on stop and running state;

"◎": means the set value of the parameter cannot be modified on the running state;

"●": means the value of the parameter is the real detection value which cannot be modified.

(The inverter has limited the automatic inspection of the modifying character of the parameters to help users avoid mismodifying)

2. "Parameter radix" is decimal (DEC), if the parameter is expressed by hex, then the parameter is separated from each other when editing. The setting range of certain bits are 0~F (hex).

3. "Default value" means the function parameter will restore to the default value during default parameters restoring. But the detected parameter or recorded value will not be restored.

4. For a better parameter protection, the inverter provides password protection to the parameters. After setting the password (set P07.00 to any non-zero number), the system will come into the state of password verification firstly after the user press PRG/ESC to come into the function code editing state. And then "0.0.0.0.0." will be displayed. Unless the user input right password, they cannot enter into the system. For the factory setting parameter zone, it needs correct factory password (remind that the users can not modify the factory parameters by themselves, otherwise, if the parameter setting is

incorrect, damage to the inverter may occur). If the password protection is unlocked, the user can modify the password freely and the inverter will work as the last setting one. When P07.00 is set to 0, the password can be canceled. If P07.00 is not 0 during powering on, then the parameter is protected by the password. When modify the parameters by serial communication, the function of the password follows the above rules, too.

Function code	Name	Detailed instruction of parameters	Default value	Modify
P00 Group Basic function group				
P00.00	Speed control mode	<p>0: Sensorless vector control mode 0 (apply to AM, SM) No need to install encoders. It is suitable in cases with low-frequency large torque and high speed control accuracy for accurate speed and torque control at medium and small power.</p> <p>1: Sensorless vector control mode 1 (apply to AM) No need to install encoders. It is suitable in cases with high speed control accuracy for accurate speed and torque control at all power ratings.</p> <p>2: SVPWM control mode No need to install encoders. It can improve the control accuracy with the advantages of stable operation, valid low-frequency torque boost and current vibration suppression and the functions of slip compensation and voltage adjustment.</p> <p>Note: AM-asynchronous motor SM-synchronous motor</p>	1	◎
P00.01	Running command channel	<p>Select the running command channel of the inverter. The control command of the inverter includes: start-up, stop, forward, reverse, jogging and fault reset.</p> <p>0: Keypad running command channel ("LOCAL/REMOT" light off) Carry out the command control by RUN, STOP/RST on the keypad.</p> <p>Set the multi-function key QUICK/JOG to FWD/REV shifting function (P07.02=3) to change the running direction; press RUN and STOP/RST simultaneously</p>	0	○

Function code	Name	Detailed instruction of parameters	Default value	Modify
		<p>in running state to make the inverter coast to stop.</p> <p>1: Terminal running command channel ("LOCAL/REMOT" flickering)</p> <p>Carry out the running command control by the forward rotation, reverse rotation and forward jogging and reverse jogging of the multi-function terminals</p> <p>2: Communication running command channel ("LOCAL/REMOT" on);</p> <p>The running command is controlled by the upper computer via communication.</p>		
P00.02	Communication running commands	<p>Select the controlling communication command channel of the inverter.</p> <p>0: MODBUS communication channel 1: PROFIBUS/CANopen communication channel 2: Ethernet communication channel 3: Reserved</p> <p>Note: 1, 2 and 3 are extension functions which need corresponding extension cards.</p>	0	○
P00.03	Max. output frequency	<p>This parameter is used to set the maximum output frequency of the inverter. Users should pay attention to this parameter because it is the foundation of the frequency setting and the speed of acceleration and deceleration.</p> <p>Setting range: P00.04~400.00Hz</p>	50.00Hz	◎
P00.04	Upper limit of running frequency	<p>The upper limit of running frequency is the upper limit of output frequency of the inverter which is lower than or equal to the maximum frequency.</p> <p>Setting range: P00.05~P00.03 (Max. output frequency)</p>	50.00Hz	◎
P00.05	Lower limit of running frequency	<p>The lower limit of running frequency is that of output frequency of the inverter.</p> <p>The inverter runs at the lower limit frequency if the set frequency is lower than the lower limit one.</p> <p>Note: Max. output frequency ≥ Upper limit frequency</p>	0.00Hz	◎

Function code	Name	Detailed instruction of parameters	Default value	Modify
		<p>≥ Lower limit frequency</p> <p>Setting range: 0.00Hz~P00.04 (Upper limit of running frequency)</p>		
P00.06	A frequency command	<p>0:Keypad</p> <p>Modify the value P00.10 (set the frequency by keypad) to modify the frequency by the keypad.</p> <p>1: AI1</p> <p>2: AI2</p> <p>3: AI3</p> <p>Set the frequency by analog input terminals. Goodrive300-02 series inverters provide 3 analog input terminals as the standard configuration, of which AI1/AI2 are the voltage/current option (0~10V/0~20mA) which can be shifted by jumpers; while AI3 is voltage input (-10V~+10V).</p> <p>Note: When analog AI1/AI2 select 0~20mA input, the corresponding voltage of 20mA is 10V.</p>	0	○
P00.07	B frequency command	<p>100.0% of the analog input setting corresponds to the maximum frequency (P00.03) in forward direction and -100.0% corresponds to the maximum frequency in reverse direction (P00.03)</p> <p>4: High-speed pulse HDI setting</p> <p>The frequency is set by high-speed pulse terminals. Goodrive300-02 series inverters provide 1 high speed pulse input as the standard configuration. The pulse frequency range is 0.0~50.00kHz.</p> <p>100.0% of the high-speed pulse input setting corresponds to the maximum frequency in forward direction (P00.03) and -100.0% corresponds to the maximum frequency in reverse direction (P00.03).</p> <p>Note: The pulse setting can only be input by multi-function terminals HDI. Set P05.00 (HDI input selection) to high speed pulse input, and set P05.49</p>	2	○

Function code	Name	Detailed instruction of parameters	Default value	Modify
		<p>(HDI high speed pulse input function selection) to frequency setting input.</p> <p>5: Simple PLC program setting The inverter runs at simple PLC program mode when P00.06=5 or P00.07=5. Set P10 (simple PLC and multi-step speed control) to select the running frequency, running direction, ACC/DEC time and the keeping time of corresponding stage. See the function description of P10 for detailed information.</p> <p>6: Multi-step speed running setting The inverter runs at multi-step speed mode when P00.06=6 or P00.07=6. Set P05 to select the current running stage, and set P10 to select the current running frequency. The multi-step speed has the priority when P00.06 or P00.07 does not equal to 6, but the setting stage can only be the 1~15 stage. The setting stage is 0~15 if P00.06 or P00.07 equals to 6.</p> <p>7: PID control setting The running mode of the inverter is process PID control when P00.06=7 or P00.07=7. It is necessary to set P09. The running frequency of the inverter is the value after PID effect. See P09 for the detailed information of the reference source, reference value, feedback source of PID.</p> <p>8: MODBUS communication setting The frequency is set by MODBUS communication. See P14 for detailed information.</p> <p>9: PROFIBUS/CANopen communication setting The frequency is set by PROFIBUS/CANopen communication. See P15 for the detailed information.</p> <p>10: Ethernet communication setting The frequency is set by Ethernet communication. See P16 for the detailed information.</p>		

Function code	Name	Detailed instruction of parameters	Default value	Modify
		11:Reserved Note: A frequency and B frequency cannot be set as the same frequency reference method.		
P00.08	B frequency command reference	0: Maximum output frequency, 100% of B frequency setting corresponds to the maximum output frequency 1: A frequency command, 100% of B frequency setting corresponds to the maximum output frequency. Select this setting if it needs to adjust on the base of A frequency command.	0	<input type="radio"/>
P00.09	Combination of setting source	0: A, the current frequency setting is A frequency command 1: B, the current frequency setting is B frequency command 2: A+B, the current frequency setting is A frequency command + B frequency command 3: A-B, the current frequency setting is A frequency command - B frequency command 4: Max (A, B): The bigger one between A frequency command and B frequency is the set frequency. 5: Min (A, B): The lower one between A frequency command and B frequency is the set frequency. Note: The combination manner can be shifted by P5 (terminal function)	0	<input type="radio"/>
P00.10	Keypad set frequency	When A and B frequency commands are selected as "keypad setting", the value of the function code is the original setting one of the frequency data of the inverter. Setting range: 0.00Hz~P00.03 (Max. output frequency)	50.00Hz	<input type="radio"/>

Function code	Name	Detailed instruction of parameters	Default value	Modify																
P00.11	ACC time 1	ACC time means the time needed if the inverter speeds up from 0Hz to the Max. One (P00.03). DEC time means the time needed if the inverter speeds down from the Max. Output frequency (P00.03) to 0Hz.	Depend on model	<input type="radio"/>																
P00.12	DEC time 1	Goodrive300-02 series inverters define four groups of ACC/DEC time which can be selected by P05. The factory default ACC/DEC time of the inverter is the first group. Setting range of P00.11 and P00.12: 0.0~3600.0s	Depend on model	<input type="radio"/>																
P00.13	Running direction	0: Runs at the default direction, the inverter runs in the forward direction. FWD/REV indicator is off. 1: Runs at the reverse direction, the inverter runs in the reverse direction. FWD/REV indicator is on. Modify the function code to shift the rotation direction of the motor. This effect equals to the shifting the rotation direction by adjusting either two of the motor lines (U, V and W). The motor rotation direction can be changed by QUICK/JOG on the keypad. Refer to parameter P07.02. Note: When the function parameter restores to the default value, the motor's running direction will restore to the factory default state, too. In some cases it should be used with caution after commissioning if the change of rotation direction is disabled. 2: Forbid to run in reverse direction: It can be used in some special cases if the reverse running is disabled.	0	<input type="radio"/>																
P00.14	Carrier frequency setting	<table border="1"> <thead> <tr> <th>Carrier frequency</th> <th>Electromagnetic noise</th> <th>Noise and leakage current</th> <th>Heating eliminating</th> </tr> </thead> <tbody> <tr> <td>1kHz</td> <td>↑ High</td> <td>↑ Low</td> <td>↑ Low</td> </tr> <tr> <td>10kHz</td> <td>↓ Low</td> <td>↓ High</td> <td>↓ High</td> </tr> <tr> <td>15kHz</td> <td>↓ Low</td> <td>↓ High</td> <td>↓ High</td> </tr> </tbody> </table>	Carrier frequency	Electromagnetic noise	Noise and leakage current	Heating eliminating	1kHz	↑ High	↑ Low	↑ Low	10kHz	↓ Low	↓ High	↓ High	15kHz	↓ Low	↓ High	↓ High	Depend on model	<input type="radio"/>
Carrier frequency	Electromagnetic noise	Noise and leakage current	Heating eliminating																	
1kHz	↑ High	↑ Low	↑ Low																	
10kHz	↓ Low	↓ High	↓ High																	
15kHz	↓ Low	↓ High	↓ High																	

Function code	Name	Detailed instruction of parameters	Default value	Modify																						
		<p>The relationship table of the motor type and carrier frequency:</p> <table border="1" data-bbox="370 288 792 715"> <thead> <tr> <th colspan="2" data-bbox="370 288 602 400">Model</th> <th data-bbox="602 288 792 400">The factory value of carrier frequency</th> </tr> </thead> <tbody> <tr> <td data-bbox="370 400 456 520" rowspan="3">380V</td> <td data-bbox="456 400 602 440">1.5~11kW</td> <td data-bbox="602 400 792 440">8kHz</td> </tr> <tr> <td data-bbox="456 440 602 480">15~55kW</td> <td data-bbox="602 440 792 480">4kHz</td> </tr> <tr> <td data-bbox="456 480 602 520">Above 75kW</td> <td data-bbox="602 480 792 520">2kHz</td> </tr> <tr> <td data-bbox="370 520 456 639" rowspan="3">500V</td> <td data-bbox="456 520 602 560">4~11kW</td> <td data-bbox="602 520 792 560">8kHz</td> </tr> <tr> <td data-bbox="456 560 602 600">15~55kW</td> <td data-bbox="602 560 792 600">4kHz</td> </tr> <tr> <td data-bbox="456 600 602 639">75kW</td> <td data-bbox="602 600 792 639">2kHz</td> </tr> <tr> <td data-bbox="370 639 456 715" rowspan="2">660V</td> <td data-bbox="456 639 602 679">22~55kW</td> <td data-bbox="602 639 792 679">4kHz</td> </tr> <tr> <td data-bbox="456 679 602 715">75kW</td> <td data-bbox="602 679 792 715">2kHz</td> </tr> </tbody> </table> <p>The advantage of high carrier frequency: ideal current waveform, little current harmonic and motor noise.</p> <p>The disadvantage of high carrier frequency: increasing switch loss, increasing inverter temperature and the impact to the output capacity.</p> <p>The inverter needs to derate on high carrier frequency. At the same time, the leakage and electrical magnetic interference will increase.</p> <p>Applying low carrier frequency is contrary to the above, too low carrier frequency will cause unstable running, torque decreasing and surge.</p> <p>The manufacturer has set a reasonable carrier frequency when the inverter is in factory. In general, users do not need to change the parameter.</p> <p>When the used frequency exceeds the default carrier frequency, the inverter needs to derate 20% for each additional 1k carrier frequency.</p> <p>Setting range: 1.0~15.0kHz</p>	Model		The factory value of carrier frequency	380V	1.5~11kW	8kHz	15~55kW	4kHz	Above 75kW	2kHz	500V	4~11kW	8kHz	15~55kW	4kHz	75kW	2kHz	660V	22~55kW	4kHz	75kW	2kHz		
Model		The factory value of carrier frequency																								
380V	1.5~11kW	8kHz																								
	15~55kW	4kHz																								
	Above 75kW	2kHz																								
500V	4~11kW	8kHz																								
	15~55kW	4kHz																								
	75kW	2kHz																								
660V	22~55kW	4kHz																								
	75kW	2kHz																								
P00.15	Motor parameter	0: No operation 1: Rotation autotuning	0	©																						

Function code	Name	Detailed instruction of parameters	Default value	Modify
	autotuning	Comprehensive motor parameter autotune It is recommended to use rotation autotuning when high control accuracy is needed. 2: Static autotuning 1 (autotune totally); It is suitable in the cases when the motor cannot de-couple from the load. 3: Static autotuning 2 (autotune partially); when the current motor is motor 1, autotune P02.06, P02.07, P02.08; and when the current motor is motor 2, autotune P12.06, P12.07, P12.08.		
P00.16	AVR function selection	0: Invalid 1: Valid during the whole procedure The auto-adjusting function of the inverter can cancel the impact on the output voltage of the inverter because of the bus voltage fluctuation.	1	○
P00.17	Reserved	Reserved	0	◎
P00.18	Function restore parameter	0: No operation 1: Restore the default value 2: Cancel the fault record Note: The function code will restore to 0 after finishing the operation of the selected function code. Restoring to the default value will cancel the user password, please use this function with caution.	0	◎
P01 Group Start-up and stop control				
P01.00	Start mode	0: Start-up directly: start from the starting frequency P01.01. 1: Start-up after DC braking: start the motor from the starting frequency after DC braking (set the parameter P01.03 and P01.04). It is suitable in the cases where reverse rotation may occur to the low inertia load during starting. 2: Start-up after speed tracing: start the rotating motor smoothly after tracking the rotation speed and	0	◎

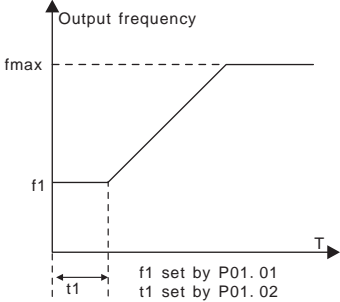
Function code	Name	Detailed instruction of parameters	Default value	Modify
		direction automatically. It is suitable in the cases where reverse rotation may occur to the big inertia load during starting. Note: ≥4kW, the function is available.		
P01.01	Starting frequency of direct start	Starting frequency of direct start-up means the original frequency during the inverter starting. See P01.02 for detailed information. Setting range: 0.00~50.00Hz	0.50Hz	☉
P01.02	Retention time of starting frequency	Set a proper starting frequency to increase the torque of the inverter during starting. During the retention time of starting frequency, the output frequency of the inverter is the starting frequency. And then, the inverter will run from the starting frequency to the set frequency. If the set frequency is lower than the starting frequency, the inverter will stop running and keep in the stand-by state. The starting frequency is not limited in the lower limit frequency.  Setting range: 0.0~50.0s	0.0s	☉
P01.03	The braking current before starting	The inverter will carry out DC braking at the braking current set before starting and it will speed up after the DC braking time. If the DC braking time is set to 0, the DC braking is invalid.	0.0%	☉
P01.04	The braking time before starting	The stronger the braking current, the bigger the braking power. The DC braking current before starting means the percentage of the rated current of the	0.00s	☉

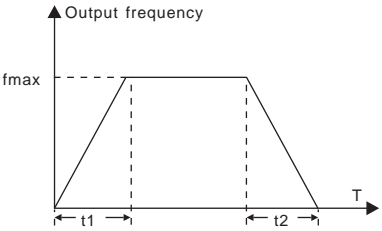
Function code	Name	Detailed instruction of parameters	Default value	Modify
		inverter. The setting range of P01.03: 0.0~100.0% The setting range of P01.04: 0.00~50.00s		
P01.05	ACC/DEC selection	The changing mode of the frequency during start-up and running. 0: Linear type The output frequency increases or decreases linearly.  1: Reserved	0	☉
P01.06	Reserved		Reserved	☉
P01.07	Reserved		Reserved	☉
P01.08	Stop mode	0: Decelerate to stop: after the stop command becomes valid, the inverter decelerates to decrease the output frequency during the set time. When the frequency decreases to stopping speed (P01.15), the inverter stops. 1: Coast to stop: after the stop command becomes valid, the inverter ceases the output immediately. And the load coasts to stop at the mechanical inertia.	0	○
P01.09	Starting frequency of DC braking	The starting frequency of stop braking: the inverter will carry on stop DC braking when the frequency arrives during the procedure of decelerating to stop.	0.00Hz	○
P01.10	Waiting time of DC braking	The waiting time of stop braking: before the stop DC braking, the inverter will close output and begin to carry on the DC braking after the waiting time. This	0.00s	○
P01.11	DC braking current	function is used to avoid the overcurrent fault caused by DC braking when the speed is too high.	0.0%	○

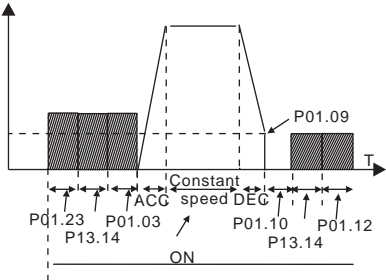
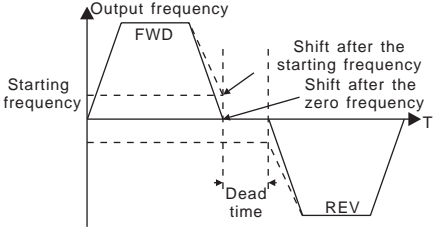
Function code	Name	Detailed instruction of parameters	Default value	Modify
P01.12	DC braking time	<p>Stop DC braking current: the DC brake added. The stronger the current, the bigger the DC braking effect. The braking time of stop braking: the retention time of DC brake. If the time is 0, the DC brake is invalid. The inverter will stop at the set deceleration time.</p>  <p>Setting range of P01.09: 0.00Hz~P00.03 Setting range of P01.10: 0.00~50.00s Setting range of P01.11: 0.0~100.0% Setting range of P01.12: 0.00~50.00s</p>	0.00s	○
P01.13	Dead time of FWD/REV rotation	<p>During the procedure of switching FWD/REV rotation, set the threshold by P01.14, which is as the table below:</p>  <p>Setting range: 0.0~3600.0s</p>	0.0s	○
P01.14	Shifting between FWD/REV rotation	<p>Set the threshold point of the inverter:</p> <ul style="list-style-type: none"> 0: Switch after zero frequency 1: Switch after the starting frequency 2: Switch after the speed reaches P01.15 and delays for P01.24 	0	◎

Function code	Name	Detailed instruction of parameters	Default value	Modify
P01.15	Stopping speed	0.00~100.00Hz	0.50Hz	☉
P01.16	Detection of stopping speed	0: Detect according to speed setting (no stopping delay) 1: Detect according to speed feedback (only valid for vector control)	1	☉
P01.17	Detection time of feedback speed	<p>If set P01.16 to 1, the feedback frequency is less than or equal to P01.15 and detect in the set time of P01.17, the inverter will stop; otherwise, the inverter will stop after the set time of P01.17.</p> <p>Setting range: 0.00~100.00s (only valid when P01.16=1)</p>	0.50s	☉
P01.18	Terminal running protection when powering on	<p>When the running commands are controlled by the terminal, the system will detect the state of the running terminal during powering on.</p> <p>0: The terminal running command is invalid when powering on. Even the running command is detected to be valid during powering on, the inverter will not run and the system keeps in the protection state until the running command is canceled and enabled again.</p> <p>1: The terminal running command is valid when powering on. If the running command is detected to be valid during powering on, the system will start the inverter automatically after the initialization.</p> <p>Note: This function should be selected with cautions, or serious result may follow.</p>	0	○

Function code	Name	Detailed instruction of parameters	Default value	Modify
P01.19	Action if running frequency < lower limit frequency (valid > 0)	<p>This function code determines the running state of the inverter when the set frequency is lower than the lower-limit one.</p> <p>0: Run at the lower-limit frequency 1: Stop 2: Hibernation</p> <p>The inverter will coast to stop when the set frequency is lower than the lower-limit one. If the set frequency is above the lower limit one again and it lasts for the time set by P01.20, the inverter will restore to the running state automatically.</p>	0	☉
P01.20	Hibernation restore delay time	<p>This function code determines the hibernation delay time. When the running frequency of the inverter is lower than the lower limit one, the inverter will pause to stand by.</p> <p>When the set frequency is above the lower limit one again and it lasts for the time set by P01.20, the inverter will run automatically.</p> <p>Note: The time is the total value when the set frequency is above the lower limit one.</p> <p>Setting range: 0.0~3600.0s (valid when P01.19=2)</p>	0.0s	○
P01.21	Restart after power off	<p>This function can enable the inverter to start or not after power off and then power on.</p> <p>0: Disable 1: Enable, if the starting need is met, the inverter will run automatically after waiting for the time defined by P01.22.</p>	0	○

Function code	Name	Detailed instruction of parameters		Default value	Modify
P01.22	The waiting time of restart after power off	<p>The function determines the waiting time before the automatic running of the inverter when powering off and then powering on.</p> <p>Setting range: 0.0~3600.0s (valid when P01.21=1)</p>		1.0s	<input type="radio"/>
P01.23	Start delay time	<p>The function determines the brake release after the running command is given, and the inverter is in a stand-by state and waits for the delay time set by P01.23.</p> <p>Setting range: 0.0~60.0s</p>		0.0s	<input type="radio"/>
P01.24	Delay time of stop speed	<p>Setting range: 0.0~100.0s</p>		0.0s	<input type="radio"/>
P01.25	0Hz output selection	<p>Select the output mode at 0Hz.</p> <p>0: Output without voltage 1: Output with voltage 2: Output at DC braking current at stopping</p>		0	<input type="radio"/>
P02 Group Motor 1					
P02.00	Motor type 1	<p>0: Asynchronous motor 1: Synchronous motor</p> <p>Note: Switch the current motor by the switching channel of P08.31.</p>	0	☉	Motor type 1
P02.01	Rated power of asynchronous	0.1~3000.0kW	Set the parameters of the controlled asynchronous motor.	Depend on model	☉

Function code	Name	Detailed instruction of parameters		Default value	Modify
	motor 1		To ensure control performance, set P02.01~P02.05 correctly according to AM name plate. Goodrive300-02 inverters		
P02.02	Rated frequency of asynchronous motor 1	0.01Hz~P00.03 (Max. output frequency)		50.00Hz	☉
P02.03	Rated speed of asynchronous motor 1	1~36000rpm	provide parameter autotuning function. Accurate parameter autotuning results from correct parameters setting.	Depend on model	☉
P02.04	Rated voltage of asynchronous motor 1	0~1200V	To ensure control performance, configure the motor according to standard adaptive motor. If the motor power and standard adaptive motor have a great gap, control performance will decrease obviously. Note: Resetting P02.01 can initialize P02.02~P02.10.	Depend on model	☉
P02.05	Rated current of asynchronous motor 1	0.8~6000.0A		Depend on model	☉
P02.06	Stator resistor of asynchronous motor 1	0.001~65.535Ω	After completing parameters autotuning, P02.06~P02.10 will update automatically. As the basic parameters of high performance vector control, the parameters have a direct impact on control performance. Note: Users cannot modify the parameters freely.	Depend on model	○
P02.07	Rotor resistor of asynchronous motor 1	0.001~65.535Ω		Depend on model	○
P02.08	Leakage inductance of asynchronous motor 1	0.1~6553.5mH		Depend on model	○
P02.09	Mutual inductance of asynchronous motor 1	0.1~6553.5mH		Depend on	○

Function code	Name	Detailed instruction of parameters		Default value	Modify
	asynchronous motor 1			model	
P02.10	Non-load current of asynchronous motor 1	0.1~6553.5A		Depend on model	○
P02.11	Magnetic saturation coefficient 1 for the iron core of AM1	0.0~100.0%		80.0%	◎
P02.12	Magnetic saturation coefficient 2 for the iron core of AM1	0.0~100.0%		68.0%	◎
P02.13	Magnetic saturation coefficient 3 for the iron core of AM1	0.0~100.0%		57.0%	◎
P02.14	Magnetic saturation coefficient 4 for the iron core of AM1	0.0~100.0%		40.0%	◎
P02.15	Rated power of synchronous motor 1	0.1~3000.0kW	Set the parameters of the controlled synchronous motor.	Depend on model	◎
P02.16	Rated frequency of	0.01Hz~P00.03 (Max. output frequency)	To ensure control performance, set P02.15~	50.00Hz	◎

Function code	Name	Detailed instruction of parameters		Default value	Modify
	synchronous motor 1		P02.19 correctly according to SM name plate.		
P02.17	Number of poles pairs for synchronous motor 1	1~50	Goodrive300-02 inverters provide parameter autotuning function. Accurate parameter autotuning results from correct parameters setting.	2	☉
P02.18	Rated voltage of synchronous motor 1	0~1200V	To ensure control performance, configure the motor according to standard adaptive motor. If the motor power and standard adaptive motor have a great gap, control performance will decrease obviously.	Depend on model	☉
P02.19	Rated current of synchronous motor 1	0.8~6000.0A	Note: Resetting P02.15 can initialize P02.16~P02.19.	Depend on model	☉
P02.20	Stator resistor of synchronous motor 1	0.001~65.535Ω	After completing parameters autotuning, P02.20~P02.22 will update automatically. As the basic parameters of high performance vector control, the parameters have a	Depend on model	○
P02.21	Direct axis inductance of synchronous motor 1	0.01~655.35mH	direct impact on control performance.	Depend on model	○
P02.22	Quadrature axis inductance of synchronous motor 1	0.01~655.35mH	When P00.15=1, P02.23 will be updated by autotuning and it does not	Depend on model	○
P02.23	Back EMF	When P00.15=2, the	need modification; When	300	○

Function code	Name	Detailed instruction of parameters		Default value	Modify
	constant of synchronous motor 1	<p>set value of P02.23 cannot be updated by autotuning, please count according to the following method.</p> <p>The counter-electromotive force constant can be counted according to the parameters on the name plate of the motor. There are three ways to count:</p> <p>1. If the name plate designates the counter-electromotive force constant K_e, then:</p> $E = (K_e * n_N * 2\pi) / 60$ <p>2. If the name plate designates the counter-electromotive force constant E' (V/1000r/min), then:</p> $E = E' * n_N / 1000$ <p>3. If the name plate does not designate the above parameters, then:</p> $E = P / \sqrt{3} * I$ <p>In the above formulas: n_N is the rated rotation speed, P is the rated power and I is the rated current.</p> <p>Setting range: 0~10000</p>	<p>P00.15=2, P02.23 cannot be updated by autotuning, so count P02.23 and update the value by manual.</p>		

Function code	Name	Detailed instruction of parameters	Default value	Modify
P02.24	Initial pole position of synchronous motor 1 (reserved)	0x0000~0xFFFF	0	●
P02.25	Identification current of synchronous motor 1 (reserved)	0%~50% (rated current of the motor)	10%	●
P02.26	Motor 1 overload protection	<p>0: No protection</p> <p>1: Common motor (with low speed compensation). Because the heat-releasing effect of the common motors will be weakened, the corresponding electric heat protection will be adjusted properly. The low speed compensation characteristic mentioned here means reducing the threshold of the overload protection of the motor whose running frequency is below 30Hz.</p> <p>2: Variable frequency motor (without low speed compensation) Because the heat-releasing effect of the specific motors will not be impacted by the rotation speed, it is not necessary to adjust the protection value during low-speed running.</p>	2	◎
P02.27	Motor 1 overload protection coefficient	<p>Times of motor overload $M = I_{out} / (I_n * K)$</p> <p>I_n is the rated current of the motor, I_{out} is the output current of the inverter and K is the motor overload protection coefficient.</p> <p>So, the bigger the value of K is, the smaller the value of M is. When $M=116\%$, the fault will be reported after 1 hour, when $M=200\%$, the fault will be reported after 1 minute, when $M \geq 400\%$, the fault will be reported instantly.</p>	100.0%	○

Function code	Name	Detailed instruction of parameters	Default value	Modify
		<p>Setting range: 20.0%~120.0%</p>		
P02.28	Correction coefficient of motor 1 power	<p>Correct the power displaying of motor 1.</p> <p>Only impact the displaying value other than the control performance of the inverter.</p> <p>Setting range: 0.00~3.00</p>	1.00	<input type="radio"/>
P02.29	Parameter display of motor 1	<p>0: Display according to the motor type</p> <p>1: Display all</p>	0	<input type="radio"/>
P03 Group Vector control				
P03.00	Speed loop proportional gain1	<p>The parameters P03.00~P03.05 only apply to vector control mode. Below the switching frequency 1 (P03.02), the speed loop PI parameters are: P03.00 and P03.01. Above the switching frequency 2 (P03.05), the speed loop PI parameters are: P03.03 and P03.04. PI parameters are gained according to the linear change of two groups of parameters. It is shown as below:</p>	20.0	<input type="radio"/>
P03.01	Speed loop integral time1		0.200s	<input type="radio"/>
P03.02	Low switching frequency		5.00Hz	<input type="radio"/>
P03.03	Speed loop proportional gain 2		20.0	<input type="radio"/>
P03.04	Speed loop integral time 2		0.200s	<input type="radio"/>
P03.05	High switching		10.00Hz	<input type="radio"/>

Function code	Name	Detailed instruction of parameters	Default value	Modify
	frequency	<p>the proportional gain and decreasing the integral time can speed up the dynamic response of the speed loop. But too high proportional gain and too low integral time may cause system vibration and overshoot. Too low proportional gain may cause system vibration and speed static deviation.</p> <p>PI has a close relationship with the inertia of the system. Adjust on the base of PI according to different loads to meet various demands.</p> <p>The setting range of P03.00: 0~200.0 The setting range of P03.01: 0.000~10.000s The setting range of P03.02: 0.00Hz~P03.05 The setting range of P03.03: 0~200.0 The setting range of P03.04: 0.000~10.000s The setting range of P03.05: P03.02~P00.03 (Max. output frequency)</p>		
P03.06	Speed loop output filter	0~8 (corresponding to 0~2 ⁸ /10ms)	0	<input type="radio"/>
P03.07	Compensation coefficient of electromotion slip	Slip compensation coefficient is used to adjust the slip frequency of the vector control and improve the speed control accuracy of the system. Adjusting the parameter properly can control the speed static error.	100%	<input type="radio"/>
P03.08	Compensation coefficient of braking slip	Setting range: 50%~200%	100%	<input type="radio"/>
P03.09	Current loop proportional coefficient P	<p>Note:</p> <p>1.These two parameters adjust the PI adjustment parameter of the current loop which affects the dynamic response speed and control accuracy directly. Generally, users do not need to change the default value.</p> <p>2.Only apply to the sensorless vector control mode 0 (P00.00=0).</p>	1000	<input type="radio"/>
P03.10	Current loop integral coefficient I		1000	<input type="radio"/>

Function code	Name	Detailed instruction of parameters	Default value	Modify
		Setting range: 0~65535		
P03.11	Torque setting method	<p>This parameter is used to enable the torque control mode, and set the torque.</p> <p>0: Torque control is invalid 1: Keypad setting torque (P03.12) 2: Analog AI1 setting torque 3: Analog AI2 setting torque 4: Analog AI3 setting torque 5: Pulse frequency HDI setting torque 6: Multi-step torque setting 7: MODBUS communication setting torque 8: PROFIBUS/CANopen communication setting torque 9: Ethernet communication setting torque 10: Reserved</p> <p>Note: Setting modes 2~10, 100% corresponds to three times of the rated current of the motor.</p>	0	<input type="radio"/>
P03.12	Keypad setting torque	Setting range: -300.0%~300.0% (rated current of the motor)	50.0%	<input type="radio"/>
P03.13	Torque reference filter time	0.000~10.000s	0.010s	<input type="radio"/>
P03.14	Upper frequency of forward rotation in torque control	0: Keypad (P03.16 sets P03.14, P03.17 sets P03.15) 1: AI1 2: AI2 3: AI3 4: Pulse frequency HDI setting upper-limit frequency 5: Multi-step setting upper-limit frequency	0	<input type="radio"/>
P03.15	Upper frequency of reverse	6: MODBUS communication setting upper-limit frequency 7: PROFIBUS/CANopen communication setting	0	<input type="radio"/>

Function code	Name	Detailed instruction of parameters	Default value	Modify
	rotation in torque control	upper-limit frequency 8: Ethernet communication setting upper-limit frequency 9: Reserved Note: Setting modes 1~9, 100% corresponds to the maximum frequency.		
P03.16	Keypad setting for upper frequency of forward rotation	This function is used to set the upper limit of the frequency. P03.16 sets the value of P03.14; P03.17 sets the value of P03.15. Setting range: 0.00Hz~P00.03 (Max. output frequency)	50.00Hz	<input type="radio"/>
P03.17	Keypad setting for upper frequency of reverse rotation		50.00Hz	<input type="radio"/>
P03.18	Upper electromotion torque source	This function code is used to select the electromotion and braking torque upper-limit setting source. 0: Keypad setting upper-limit frequency (P03.20 sets P03.18, P03.21 sets P03.19)	0	<input type="radio"/>
P03.19	Upper braking torque source	1: AI1 2: AI2 3: AI3 4: HDI 5: MODBUS communication 6: PROFIBUS/CANopen communication 7: Ethernet communication 8: Reserved	0	<input type="radio"/>

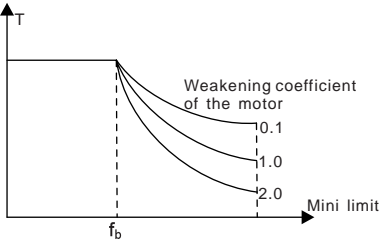
Function code	Name	Detailed instruction of parameters	Default value	Modify
		Note: Setting modes 1~8,100% corresponds to three times of the motor current.		
P03.20	Keypad setting of electromotion torque	The function code is used to set the limit of the torque. Setting range: 0.0~300.0% (motor rated current)	180.0%	<input type="radio"/>
P03.21	Keypad setting of braking torque		180.0%	<input type="radio"/>
P03.22	Weakening coefficient in constant power zone	The function code is used when the motor is under weakening control. 	0.3	<input type="radio"/>
P03.23	Lowest weakening point in constant power zone	P03.22 and P03.23 are valid at constant power. The motor will enter into the weakening state when the motor runs at rated speed. Change the weakening curve by modifying the weakening control coefficient. The bigger the weakening control coefficient is, the steeper the weak curve is. P03.22 is only valid for vector mode 1. The setting range of P03.22: 0.1~2.0 The setting range of P03.23: 10%~100%	20%	<input type="radio"/>
P03.24	Max. voltage limit	P03.24 set the Max. voltage of the inverter, which is dependent on the site situation. The setting range: 0.0~120.0%	100.0%	<input checked="" type="radio"/>
P03.25	Pre-exciting time	Preactivate the motor when the inverter starts up. Build up a magnetic field inside the inverter to	0.300s	<input type="radio"/>

Function code	Name	Detailed instruction of parameters	Default value	Modify
		improve the torque performance during the starting process. The setting time: 0.000~10.000s		
P03.26	Weak magnetic proportional gain	0~4000 Note: P03.24~P03.26 are invalid for vector mode 1.	1000	○
P03.27	Vector control speed	0: Display the actual value 1: Display the setting value	0	○
P03.28	Compensation coefficient of static friction	0.0~100.0% Adjust P03.28 to compensate the coefficient of static friction. Only valid when the running frequency is below 1Hz.	0.0%	○
P03.29	Compensation coefficient of dynamic friction	0.0~100.0% Adjust P03.29 to compensate the coefficient of static friction. Only valid when the running frequency is above 1Hz.	0.0%	○
P04 Group SVPWM control				
P04.00	Motor 1 V/F curve setting	The function code defines the V/F curve of Goodrive300-02 motor 1 to meet the need of different loads. 0: Straight line V/F curve; applying to the constant torque load 1: Multi-dots V/F curve 2: 1.3 th power low torque V/F curve 3: 1.7 th power low torque V/F curve 4: 2.0 th power low torque V/F curve Curves 2~4 apply to the torque loads such as fans and water pumps. Users can adjust according to the features of the loads to achieve a best energy-consuming effect. 5: Customized V/F (V/F separation); on this mode, V	0	◎

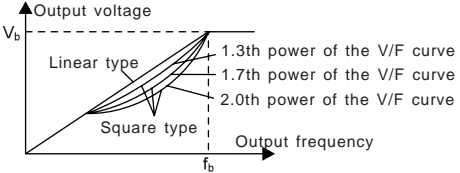
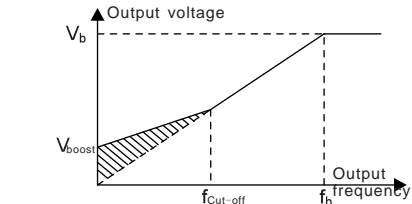
Function code	Name	Detailed instruction of parameters	Default value	Modify
		<p>and f can be separated and f can be adjusted through the frequency reference channel set by P00.06 or the voltage reference channel set by P04.27 to change the feature of the curve.</p> <p>Note: V_b in the below picture is the motor rated voltage and f_b is the motor rated frequency.</p> 		
P04.01	Torque boost of motor 1	Torque boost to the output voltage for the features of low frequency torque. P04.01 is for the Max. Output voltage V_b .	0.0%	○
P04.02	Torque boost close of motor 1	<p>P04.02 defines the percentage of close frequency of manual torque to f_b.</p> <p>Torque boost should be selected according to the load. The bigger the load is, the bigger the boost is. Too big torque boost is inappropriate because the motor will run with over-magnetic, and the current of the inverter will increase to raise the temperature of the inverter and decrease the efficiency.</p> <p>When the torque boost is set to 0.0%, the inverter is automatic torque boost.</p> <p>Torque boost threshold: under the threshold, the torque boost is valid, but over the threshold, the torque boost is invalid.</p> 	20.0%	○

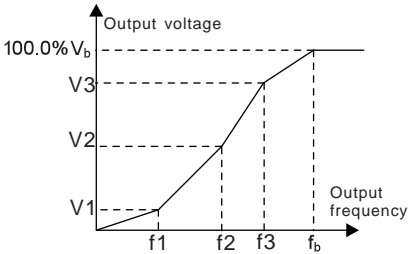
Function code	Name	Detailed instruction of parameters	Default value	Modify
		The setting range of P04.01: 0.0%: (automatic) 0.1%~10.0% The setting range of P04.02: 0.0%~50.0%		
P04.03	V/F frequency 1 of motor 1	When P04.00=1, the user can set V/F curve through P04.03~P04.08. V/F is generally set according to the load of the motor.	0.00Hz	<input type="radio"/>
P04.04	V/F voltage 1 of motor 1	<p>Note: $V1 < V2 < V3$, $f1 < f2 < f3$. Too high low frequency voltage will heat the motor excessively or cause damage. The inverter may stall when overcurrent or overcurrent protection.</p> 	00.0%	<input type="radio"/>
P04.05	V/F frequency 2 of motor 1		00.00Hz	<input type="radio"/>
P04.06	V/F voltage 2 of motor 1		00.0%	<input type="radio"/>
P04.07	V/F frequency 3 of motor 1		00.00Hz	<input type="radio"/>
P04.08	V/F voltage 3 of motor 1		<p>The setting range of P04.03: 0.00Hz~P04.05</p> <p>The setting range of P04.04: 0.0%~110.0% (the rated voltage of motor 1)</p> <p>The setting range of P04.05: P04.03~P04.07</p> <p>The setting range of P04.06: 0.0%~110.0% (the rated voltage of motor 1)</p> <p>The setting range of P04.07: P04.05~P02.02 (the rated frequency of motor 1) or P04.05~P02.16 (the rated frequency of motor 1)</p> <p>The setting range of P04.08: 0.0%~110.0% (the rated voltage of motor 1)</p>	00.0%
P04.09	V/F slip compensation gain of motor 1	This function code is used to compensate the change of the rotation speed caused by load during compensation SVPWM control to improve the rigidity of the motor. It can be set to the rated slip frequency of the motor which is counted as below:	100.0%	<input type="radio"/>

Function code	Name	Detailed instruction of parameters	Default value	Modify
		$\Delta f = f_b - n * p / 60$ Of which, f_b is the rated frequency of the motor, its function code is P02.02; n is the rated rotating speed of the motor and its function code is P02.03; p is the pole pair of the motor. 100.0% corresponds to the rated slip frequency Δf . Setting range: 0.0~200.0%		
P04.10	Vibration control factor at low frequency of motor 1	In SVPWM control mode, current fluctuation may occur to the motor at some frequency, especially the motor with big power. The motor cannot run stably or overcurrent may occur. These phenomena can be canceled by adjusting this parameter. The setting range of P04.10: 0~100 The setting range of P04.11: 0~100 The setting range of P04.12: 0.00Hz~P00.03 (Max. output frequency)	10	<input type="radio"/>
P04.11	Vibration control factor at high frequency of motor 1		10	<input type="radio"/>
P04.12	Vibration control threshold of motor 1		30.00Hz	<input type="radio"/>
P04.13	Motor 2 V/F curve setting	The group of parameters defines the V/F setting means of Goodrive300-02 motor 2 to meet various requirements of different loads. See P04.00~P04.12 for the detailed function code instruction. Note: P04 group includes two sets of V/F parameters of the motor which cannot display simultaneously and are only valid for the selected motor. The motor selection can be selected by defined channels in P08.31 or terminal function 35 "the shift between motor 1 and motor 2".	0	<input checked="" type="radio"/>
P04.14	Torque boost of motor 2		0.0%	<input type="radio"/>
P04.15	Torque boost close of motor 2		20.0%	<input type="radio"/>
P04.16	V/F frequency 1 of motor 2		0.00Hz	<input type="radio"/>

Function code	Name	Detailed instruction of parameters	Default value	Modify
P04.17	V/F voltage 1 of motor 2		00.0%	<input type="radio"/>
P04.18	V/F frequency 2 of motor 2		00.00Hz	<input type="radio"/>
P04.19	V/F voltage 2 of motor 2		00.0%	<input type="radio"/>
P04.20	V/F frequency 3 of motor 2		00.00Hz	<input type="radio"/>
P04.21	V/F voltage 3 of motor 2		00.0%	<input type="radio"/>
P04.22	V/F slip compensation gain of motor 2		100.0%	<input type="radio"/>
P04.23	Vibration control factor at low frequency of motor 2		In SVPWM control mode, current fluctuation may occur to the motor at some frequency, especially the motor with big power. The motor cannot run stably or overcurrent may occur. These phenomena can be canceled by adjusting this parameter. The setting range of P04.23: 0~100 The setting range of P04.24: 0~100 The setting range of P04.25: 0.00Hz~P00.03 (Max. output frequency)	10
P04.24	Vibration control factor at high frequency of motor 2	10		<input type="radio"/>
P04.25	Vibration control threshold of motor 2	30.00Hz		<input type="radio"/>

Function code	Name	Detailed instruction of parameters	Default value	Modify
P04.26	Energy-saving operation	0: No operation 1: Automatic energy-saving operation Motors will automatically adjust the output voltage to save energy at light loads.	0	☉
P04.27	Voltage setting	Select the output setting channel at V/F curve separation. 0: Keypad: the output voltage is determined by P04.28. 1: AI1 2: AI2 3: AI3 4: HDI1 5: Multi-step speed 6: PID 7: MODBUS communication 8: PROFIBUS/CANopen communication 9: Ethernet communication 10: Reserved Note: 100% corresponds to the rated voltage of the motor.	0	○
P04.28	Keypad setting voltage	The function code is the voltage displaying when the voltage is set through keypad. The setting range: 0.0%~100.0%	100.0%	○
P04.29	Voltage increasing time	Voltage increasing time is the time when the inverter accelerates from the minimum output voltage to the maximum output voltage.	5.0s	○
P04.30	Voltage decreasing time	Voltage decreasing time is the time when the inverter decelerates from the maximum output voltage to the minimum output voltage. The setting range: 0.0~3600.0s	5.0s	○
P04.31	Maximum output voltage	Set the upper and low limit of the output voltage.	100.0%	☉

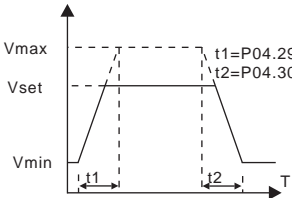
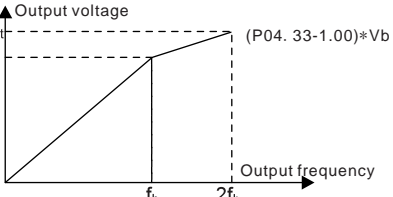
Function code	Name	Detailed instruction of parameters	Default value	Modify
P04.32	Minimum output voltage	 <p>The setting range of P04.31: P04.32~100.0% (the rated voltage of the motor) The setting range of P04.32: 0.0%~P04.31</p>	0.0%	☉
P04.33	Weakening coefficient in constant power zone	<p>The function is used to adjust the output voltage of inverter in SVPWM mode in weak magnetic.</p> <p>Note: Invalid in constant-torque mode</p>  <p>The setting range of P04.33: 1.00~1.30</p>	1.00	○
P05 Group Input terminals				
P05.00	HDI input selection	0: High-speed pulse input. See P05.49~P05.54 1: Digital input. See P05.09	0	☉
P05.01	S1 terminal function selection	0: No function	1	☉
		1: Forward rotation operation 2: Reverse rotation operation		
P05.02	S2 terminal function selection	3: 3-wire control operation (SIn)	4	☉
		4: Forward jogging 5: Reverse jogging		
P05.03	S3 terminal function selection	6: Coast to stop	7	☉
		7: Fault reset 8: Operation pause		
P05.04	S4 terminal function selection	9: External fault input 10: Frequency setting increasing (UP) 11: Frequency setting decreasing (DOWN)	0	☉

Function code	Name	Detailed instruction of parameters	Default value	Modify
P05.05	S5 terminal function selection	12: Frequency setting clear 13: Shift between A setting and B setting 14: Shift between combination setting and A setting	0	☉
P05.06	S6 terminal function selection	15: Shift between combination setting and B setting 16: Multi-step speed terminal 1 17: Multi-step speed terminal 2	0	☉
P05.07	S7 terminal function selection	18: Multi-step speed terminal 3 19: Multi-step speed terminal 4 20: Multi-step speed pause	0	☉
P05.08	S8 terminal function selection	21: ACC/DEC time 1 22: ACC/DEC time 2 23: Simple PLC stop reset	0	☉
P05.09	HDI terminal function selection	24: Simple PLC pause 25: PID control pause 26: Traverse pause(stop at the current frequency) 27: Traverse reset(return to the center frequency) 28: Counter reset 29: Torque control disabling 30: ACC/DEC disabling 31: Counter triggering 32: Length reset 33: Cancel the frequency change setting temporarily 34: DC brake 35: Shift the motor 1 to motor 2 36: Shift the command to the keypad 37: Shift the command to the terminal 38: Shift the command to the communication 39: Pre-magnetized command 40: Consumption power clear 41: Consumption power holding 42~60: Reserved 61: PID polarity shifting 62~63: Reserved	0	☉

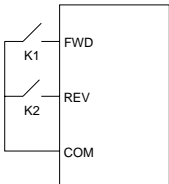
Function code	Name	Detailed instruction of parameters	Default value	Modify																				
P05.10	Polarity selection of input terminals	<p>The function code is used to set the polarity of input terminals.</p> <p>Set the bit to 0, the input terminal is anode.</p> <p>Set the bit to 1, the input terminal is cathode.</p> <table border="1" style="margin-left: auto; margin-right: auto;"> <tr> <td></td> <td>BIT8</td> <td>BIT7</td> <td>BIT6</td> <td>BIT5</td> </tr> <tr> <td></td> <td>HDI</td> <td>S8</td> <td>S7</td> <td>S6</td> </tr> <tr> <td>BIT4</td> <td>BIT3</td> <td>BIT2</td> <td>BIT1</td> <td>BIT0</td> </tr> <tr> <td>S5</td> <td>S4</td> <td>S3</td> <td>S2</td> <td>S1</td> </tr> </table> <p>The setting range: 0x000~0x1FF</p>		BIT8	BIT7	BIT6	BIT5		HDI	S8	S7	S6	BIT4	BIT3	BIT2	BIT1	BIT0	S5	S4	S3	S2	S1	0x000	○
	BIT8	BIT7	BIT6	BIT5																				
	HDI	S8	S7	S6																				
BIT4	BIT3	BIT2	BIT1	BIT0																				
S5	S4	S3	S2	S1																				
P05.11	ON-OFF filter time	<p>Set the sampling filter time of S1~S8 and HDI terminals. If the interference is strong, increase the parameter to avoid the disoperation.</p> <p>The setting range: 0.000~1.000s</p>	0.010s	○																				
P05.12	Virtual terminals setting	<p>0x000~0x1FF (0: disabling, 1: enabling)</p> <p>BIT0: S1 virtual terminal</p> <p>BIT1: S2 virtual terminal</p> <p>BIT2: S3 virtual terminal</p> <p>BIT3: S4 virtual terminal</p> <p>BIT4: S5 virtual terminal</p> <p>BIT5: S6 virtual terminal</p> <p>BIT6: S7 virtual terminal</p> <p>BIT7: S8 virtual terminal</p> <p>BIT8: HDI virtual terminal</p>	0x000	◎																				
P05.13	Terminals control running mode	<p>Set the operation mode of the terminals control</p> <p>0: 2-wire control 1; the enabling and the direction combine into one. This mode is widely used. It determines the rotation direction by the defined FWD and REV terminals command.</p> <div style="display: flex; align-items: center; justify-content: center;">  <table border="1" style="margin-left: 20px;"> <thead> <tr> <th>FWD</th> <th>REV</th> <th>Running command</th> </tr> </thead> <tbody> <tr> <td>OFF</td> <td>OFF</td> <td>Stop</td> </tr> <tr> <td>ON</td> <td>OFF</td> <td>FWD running</td> </tr> <tr> <td>OFF</td> <td>ON</td> <td>REV running</td> </tr> <tr> <td>ON</td> <td>ON</td> <td>Hold</td> </tr> </tbody> </table> </div> <p>1: 2-wire control 2; the enabling and the direction</p>	FWD	REV	Running command	OFF	OFF	Stop	ON	OFF	FWD running	OFF	ON	REV running	ON	ON	Hold	0	◎					
FWD	REV	Running command																						
OFF	OFF	Stop																						
ON	OFF	FWD running																						
OFF	ON	REV running																						
ON	ON	Hold																						

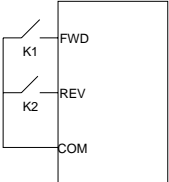
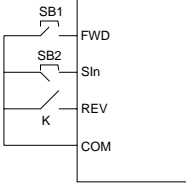
Function code	Name	Detailed instruction of parameters	Default value	Modify																																				
		<p>separate. The defined FWD by this mode is the enabling terminal. The direction depends on the state of the defined REV.</p> <div style="display: flex; align-items: center; justify-content: center;">  <table border="1" style="margin-left: 20px;"> <tr> <td>FWD</td> <td>REV</td> <td>Running command</td> </tr> <tr> <td>OFF</td> <td>OFF</td> <td>Stop</td> </tr> <tr> <td>ON</td> <td>OFF</td> <td>FWD running</td> </tr> <tr> <td>OFF</td> <td>ON</td> <td>Hold</td> </tr> <tr> <td>ON</td> <td>ON</td> <td>REV running</td> </tr> </table> </div> <p>2: 3-wire control 1; SIn is the enabling terminal on this mode, and the running command is caused by FWD and the direction is controlled by REV. When the inverter runs, SIn needs to be in closed state, a rising edge signal is caused by FWD and the running direction is controlled by REV; when the inverter stops, SIn needs to be disconnected.</p> <div style="display: flex; align-items: center; justify-content: center;">  </div> <p>In operation, the direction is:</p> <table border="1" style="margin-left: auto; margin-right: auto;"> <thead> <tr> <th>SIn</th> <th>REV</th> <th>Previous direction</th> <th>Current direction</th> </tr> </thead> <tbody> <tr> <td rowspan="2">ON</td> <td rowspan="2">OFF→ON</td> <td>FWD</td> <td>REV</td> </tr> <tr> <td>REV</td> <td>FWD</td> </tr> <tr> <td rowspan="2">ON</td> <td rowspan="2">ON→OFF</td> <td>REV</td> <td>FWD</td> </tr> <tr> <td>FWD</td> <td>REV</td> </tr> <tr> <td rowspan="2">ON→OFF</td> <td>ON</td> <td colspan="2" rowspan="2">Decelerate to stop</td> </tr> <tr> <td>OFF</td> </tr> </tbody> </table> <p>3: 3-wire control 2; SIn is the enabling terminal on this mode, and the running command is caused by FWD or REV and both of them control the running direction. When the inverter runs, SIn needs to be in closed state, a rising edge signal is caused by FWD or REV</p>	FWD	REV	Running command	OFF	OFF	Stop	ON	OFF	FWD running	OFF	ON	Hold	ON	ON	REV running	SIn	REV	Previous direction	Current direction	ON	OFF→ON	FWD	REV	REV	FWD	ON	ON→OFF	REV	FWD	FWD	REV	ON→OFF	ON	Decelerate to stop		OFF		
FWD	REV	Running command																																						
OFF	OFF	Stop																																						
ON	OFF	FWD running																																						
OFF	ON	Hold																																						
ON	ON	REV running																																						
SIn	REV	Previous direction	Current direction																																					
ON	OFF→ON	FWD	REV																																					
		REV	FWD																																					
ON	ON→OFF	REV	FWD																																					
		FWD	REV																																					
ON→OFF	ON	Decelerate to stop																																						
	OFF																																							

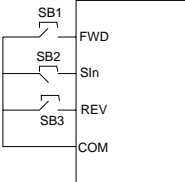
Function code	Name	Detailed instruction of parameters	Default value	Modify																					
		<p>and the running direction is controlled by FWD or REV; when the inverter stops, SIn needs to be disconnected.</p>  <table border="1" data-bbox="344 507 819 794"> <thead> <tr> <th>SIn</th> <th>FWD</th> <th>REV</th> <th>Running direction</th> </tr> </thead> <tbody> <tr> <td rowspan="2">ON</td> <td>OFF→ON</td> <td>ON</td> <td>FWD</td> </tr> <tr> <td></td> <td>OFF</td> <td>FWD</td> </tr> <tr> <td rowspan="2">ON</td> <td>ON</td> <td rowspan="2">OFF→ON</td> <td>REV</td> </tr> <tr> <td>OFF</td> <td>REV</td> </tr> <tr> <td>ON→OFF</td> <td></td> <td></td> <td>Decelerate to stop</td> </tr> </tbody> </table> <p>SIn: 3-wire running control, FWD: forward running, REV: reverse running</p> <p>Note: For the 2-wire running mode, when FWD/REV terminal is valid, the inverter stops because of the stopping command from other sources, even the control terminal FWD/REV keeps valid; the inverter will not work when the stopping command is canceled. Only when FWD/REV is relaunched, the inverter can start again. For example, the valid STOP/RST stop at PLC single-cycle stop, fixed length and terminal control (see P07.04).</p>	SIn	FWD	REV	Running direction	ON	OFF→ON	ON	FWD		OFF	FWD	ON	ON	OFF→ON	REV	OFF	REV	ON→OFF			Decelerate to stop		
SIn	FWD	REV	Running direction																						
ON	OFF→ON	ON	FWD																						
		OFF	FWD																						
ON	ON	OFF→ON	REV																						
	OFF		REV																						
ON→OFF			Decelerate to stop																						
P05.14	Switch-on delay of S1 terminal	The function code defines the corresponding delay time of electrical level of the programmable input terminals from switching on to switching off.	0.000s	○																					
P05.15	Switch-off delay of S1 terminal		0.000s	○																					

Function code	Name	Detailed instruction of parameters	Default value	Modify
P05.16	Switch-on delay of S2 terminal	<p>Setting range: 0.000~50.000s</p>	0.000s	<input type="radio"/>
P05.17	Switch-off delay of S2 terminal		0.000s	<input type="radio"/>
P05.18	Switch-on delay of S3 terminal		0.000s	<input type="radio"/>
P05.19	Switch-off delay of S3 terminal		0.000s	<input type="radio"/>
P05.20	Switch-on delay of S4 terminal		0.000s	<input type="radio"/>
P05.21	Switch-off delay of S4 terminal		0.000s	<input type="radio"/>
P05.22	Switch-on delay of S5 terminal		0.000s	<input type="radio"/>
P05.23	Switch-off delay of S5 terminal		0.000s	<input type="radio"/>
P05.24	Switch-on delay of S6 terminal		0.000s	<input type="radio"/>
P05.25	Switch-off delay of S6 terminal		0.000s	<input type="radio"/>
P05.26	Switch-on delay of S7 terminal	0.000s	<input type="radio"/>	

Function code	Name	Detailed instruction of parameters	Default value	Modify
P05.27	Switch-off delay of S7 terminal		0.000s	<input type="radio"/>
P05.28	Switch-on delay of S8 terminal		0.000s	<input type="radio"/>
P05.29	Switch-off delay of S8 terminal		0.000s	<input type="radio"/>
P05.30	Switch-on delay of HDI terminal		0.000s	<input type="radio"/>
P05.31	Switch-off delay of HDI terminal		0.000s	<input type="radio"/>
P05.32	Lower limit of AI1	<p>The function code defines the relationship between the analog input voltage and its corresponding set value. If the analog input voltage beyond the set minimum or maximum input value, the inverter will count at the minimum or maximum one.</p> <p>When the analog input is the current input, the corresponding voltage of 0~20mA is 0~10V. In different cases, the corresponding rated value of 100.0% is different. See the application for detailed information.</p> <p>The figure below illustrates different applications:</p>	0.00V	<input type="radio"/>
P05.33	Corresponding setting of the lower limit of AI1		0.0%	<input type="radio"/>
P05.34	Upper limit of AI1		10.00V	<input type="radio"/>
P05.35	Corresponding setting of the upper limit of AI1		100.0%	<input type="radio"/>
P05.36	AI1 input filter time		0.100s	<input type="radio"/>
P05.37	Lower limit of AI2		0.00V	<input type="radio"/>
P05.38	Corresponding setting of		0.0%	<input type="radio"/>

Function code	Name	Detailed instruction of parameters	Default value	Modify	
	the lower limit of AI2				
P05.39	Upper limit of AI2		10.00V	<input type="radio"/>	
P05.40	Corresponding setting of the upper limit of AI2		100.0%	<input type="radio"/>	
P05.41	AI2 input filter time		Input filter time: This parameter is used to adjust the sensitivity of the analog input. Increasing the value properly can enhance the anti-interference of the analog, but weaken the sensitivity of the analog input.	0.100s	<input type="radio"/>
P05.42	Lower limit of AI3			-10.00V	<input type="radio"/>
P05.43	Corresponding setting of the lower limit of AI3		Note: Analog AI1 and AI2 can support 0~10V or 0~20mA input. When AI1 and AI2 selects 0~20mA input, the corresponding voltage of 20mA is 10V. AI3 can support -10V~+10V input.	-100.0%	<input type="radio"/>
P05.44	Middle value of AI3		The setting range of P05.32: 0.00V~P05.34 The setting range of P05.33: -100.0%~100.0%	0.00V	<input type="radio"/>
P05.45	Corresponding middle setting of AI3		The setting range of P05.34: P05.32~10.00V The setting range of P05.35: -100.0%~100.0% The setting range of P05.36: 0.000s~10.000s The setting range of P05.37: 0.00V~P05.39	0.0%	<input type="radio"/>
P05.46	Upper limit of AI3		The setting range of P05.38: -100.0%~100.0% The setting range of P05.39: P05.37~10.00V	10.00V	<input type="radio"/>
P05.47	Corresponding setting of the upper limit of AI3		The setting range of P05.40: -100.0%~100.0% The setting range of P05.41: 0.000s~10.000s The setting range of P05.42: -10.00V~P05.44 The setting range of P05.43: -100.0%~100.0%	100.0%	<input type="radio"/>
P05.48	AI3 input filter time	The setting range of P05.44: P05.42~P05.46 The setting range of P05.45: -100.0%~100.0% The setting range of P05.46: P05.44~10.00V The setting range of P05.47: -100.0%~100.0% The setting range of P05.48: 0.000s~10.000s	0.100s	<input type="radio"/>	

Function code	Name	Detailed instruction of parameters	Default value	Modify
P05.49	HDI high-speed pulse input function selection	The function selection when HDI terminals is high-speed pulse input 0: Frequency setting input, frequency setting source 1: Counter input, high-speed pulse counter input terminals 2: Length counting input, length counter input terminals	0	☉
P05.50	Lower limit frequency of HDI	0.000kHz~P05.52	0.000 kHz	○
P05.51	Corresponding setting of HDI lower limit frequency	-100.0%~100.0%	0.0%	○
P05.52	Upper limit frequency of HDI	P05.50~50.000kHz	50.000 kHz	○
P05.53	Corresponding setting of HDI upper limit frequency	-100.0%~100.0%	100.0%	○
P05.54	HDI frequency input filter time	0.000s~10.000s	0.010s	○
P06 Group Output terminals				
P06.00	HDO output	The function is used to select the high-speed pulse output terminals function. 0: Open collector high-speed pulse output: The Max. pulse frequency is 50.0kHz. See P06.27~P06.31 for detailed information of the related functions.	0	☉

Function code	Name	Detailed instruction of parameters	Default value	Modify
		1: Open collector output. See P06.02 for detailed information of the related functions.		
P06.01	Y output	0: Invalid	0	○
P06.02	HDO output	1: In operation	0	○
P06.03	Relay RO1 output	2: Forward rotation operation 3: Reverse rotation operation	1	○
P06.04	Relay RO2 output	4: Jogging operation 5: Inverter fault 6: Frequency degree test FDT1 7: Frequency degree test FDT2 8: Frequency arrival 9: Zero speed running 10: Upper limit frequency arrival 11: Lower limit frequency arrival 12: Ready for operation 13: Pre-magnetizing 14: Overload pre-alarm 15: Underload pre-alarm 16: Completion of simple PLC stage 17: Completion of simple PLC cycle 18: Setting count value arrival 19: Reference count value arrival 20: External fault valid 21: Length arrival 22: Running time arrival 23: MODBUS communication virtual terminals output 24: PROFIBUS/CANopen communication virtual terminals output 25: Ethernet communication virtual terminals output 26: Completion of DC bus voltage setting 27~30: Reserved	5	○
P06.05	Polarity of output	The function code is used to set the pole of the output terminal.	00	○

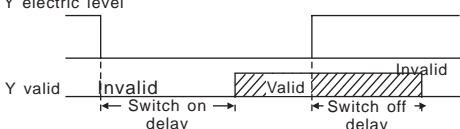
Function code	Name	Detailed instruction of parameters	Default value	Modify								
	terminals	When the current bit is set to 0, input terminal is positive. When the current bit is set to 1, input terminal is negative. <table border="1" style="margin: 10px auto;"> <tr> <td>BIT3</td> <td>BIT2</td> <td>BIT1</td> <td>BIT0</td> </tr> <tr> <td>RO2</td> <td>RO1</td> <td>HDO</td> <td>Y</td> </tr> </table> Setting range: 00~0F	BIT3	BIT2	BIT1	BIT0	RO2	RO1	HDO	Y		
BIT3	BIT2	BIT1	BIT0									
RO2	RO1	HDO	Y									
P06.06	Y switch-on delay time	The function code defines the corresponding delay time of the electrical level change during the programmable terminal switching on and off. Y electric level 	0.000s	<input type="radio"/>								
P06.07	Y switch-off delay time		0.000s	<input type="radio"/>								
P06.08	HDO switch-on delay time		0.000s	<input type="radio"/>								
P06.09	HDO switch-off delay time		0.000s	<input type="radio"/>								
P06.10	RO1 switch-on delay time		0.000s	<input type="radio"/>								
P06.11	RO1 switch-off delay time		The setting range: 0.000~50.000s Note: P06.08 and P06.08 are valid only when P06.00=1.	0.000s	<input type="radio"/>							
P06.12	RO2 switch-on delay time		0.000s	<input type="radio"/>								
P06.13	RO2 switch-off delay time		0.000s	<input type="radio"/>								
P06.14	AO1 output		0: Running frequency	0	<input type="radio"/>							
P06.15	AO2 output		1: Set frequency	0	<input type="radio"/>							
P06.16	HDO high-speed		2: Ramp reference frequency 3: Running rotation speed	0	<input type="radio"/>							

Function code	Name	Detailed instruction of parameters	Default value	Modify
	pulse output	4: Output current (relative to the rated current of the inverter) 5: Output current (relative to the rated current of the motor) 6: Output voltage 7: Output power 8: Set torque value 9: Output torque 10: AI1 input value 11: AI2 input value 12: AI3 input value 13: High-speed pulse HDI input value 14: MODBUS communication set value 1 15: MODBUS communication set value 2 16: PROFIBUS/CANopen communication set value 1 17: PROFIBUS/CANopen communication set value 2 18: Ethernet communication set value 1 19: Ethernet communication set value 2 20~21: Reserved 22: Torque current (relative to the rated current of the motor) 23: Ramp reference frequency (with sign) 24~30: Reserved		
P06.17	Lower output limit of AO1	The above function codes define the relative relationship between the output value and analog output. When the output value exceeds the range of set maximum or minimum output, it will count according to the low-limit or upper-limit output. When the analog output is current output, 1mA equals to 0.5V. In different cases, the corresponding analog output of 100% of the output value is different. See each application for detailed information.	0.0%	<input type="radio"/>
P06.18	Corresponding AO1 output of lower limit		0.00V	<input type="radio"/>
P06.19	Upper output limit of AO1		100.0%	<input type="radio"/>
P06.20	Corresponding AO1 output of upper limit		10.00V	<input type="radio"/>

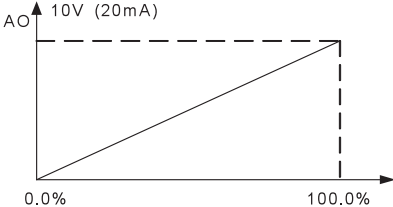
Function code	Name	Detailed instruction of parameters	Default value	Modify
P06.21	AO1 output filter time		0.000s	<input type="radio"/>
P06.22	Lower output limit of AO2		0.0%	<input type="radio"/>
P06.23	Corresponding AO2 output of lower limit		0.00V	<input type="radio"/>
P06.24	Upper output limit of AO2		100.0%	<input type="radio"/>
P06.25	Corresponding AO2 output of upper limit		10.00V	<input type="radio"/>
P06.26	AO2 output filter time		0.000s	<input type="radio"/>
P06.27	Lower output limit of HDO		0.0%	<input type="radio"/>
P06.28	Corresponding HDO output of lower limit		0.00kHz	<input type="radio"/>
P06.29	Upper output limit of HDO		100.0%	<input type="radio"/>
P06.30	Corresponding HDO output of upper limit		50.00kHz	<input type="radio"/>
P06.31	HDO output filter time		0.000s	<input type="radio"/>
P07 Group Human machine interface				
P07.00	User's password	0~65535 The password protection will be valid when setting any non-zero number. 00000: Clear the previous user's password, and make the password protection invalid. After the set user's password becomes valid, if the	0	<input type="radio"/>

Function code	Name	Detailed instruction of parameters	Default value	Modify
		<p>password is incorrect, users cannot enter the parameter menu. Only correct password can make the user check or modify the parameters. Please remember all users' passwords.</p> <p>Retreat editing state of the function codes and the password protection will become valid in a minute. If the valid password is available, press PRG/ESC to enter into the editing state of the function codes, and then "0.0.0.0.0" will be displayed. Unless input right password, the operator cannot enter into it.</p> <p>Note: Restoring to the default value can clear the password, please use it with caution.</p>		
P07.01	Parameter copy	<p>The function code determines the manner of parameters copy.</p> <p>0: No operation</p> <p>1: Upload the local function parameter to the keypad</p> <p>2: Download the keypad function parameter to local address (including the motor parameters)</p> <p>3: Download the keypad function parameter to local address (excluding the motor parameter of P02 and P12 group)</p> <p>4: Download the keypad function parameters to local address (only for the motor parameter of P02 and P12 group)</p> <p>Note: After completing the 1~4 operations, the parameter will restore to 0 automatically; the function of upload and download excludes the factory parameters of P29.</p>	0	◎
P07.02	QUICK/JOG function selection	<p>0: No function</p> <p>1: Jogging. Press QUICK/JOG to begin the jogging running.</p> <p>2: Shift the display state by the shifting key. Press QUICK/JOG to shift the displayed function code from</p>	1	◎

Function code	Name	Detailed instruction of parameters	Default value	Modify
		<p>right to left.</p> <p>3: Shift between forward rotations and reverse rotations. Press QUICK/JOG to shift the direction of the frequency commands. This function is only valid in the keypad commands channels.</p> <p>4: Clear UP/DOWN settings. Press QUICK/JOG to clear the set value of UP/DOWN.</p> <p>5: Coast to stop. Press QUICK/JOG to coast to stop.</p> <p>6: Shift the reference manner of running commands. Press QUICK/JOG to shift the reference manner of running commands.</p> <p>7: Quick commission mode (commission according to the non-factory parameter)</p> <p>Note: Press QUICK/JOG to shift between forward rotation and reverse rotation, the inverter does not remember the state after shifting during powering off. The inverter will run in the running direction set according to parameter P00.13 during next powering on.</p>		
P07.03	Shifting sequence selection of QUICK/JOG commands	<p>When P07.02=6, set the shifting sequence of running command channels.</p> <p>0: Keypad control→ terminals control→ communication control</p> <p>1: Keypad control←→terminals control</p> <p>2: Keypad control←→communication control</p> <p>3: Terminals control←→communication control</p>	0	○
P07.04	STOP/RST stop function	<p>STOP/RST is valid for stop function. STOP/RST is valid in any state for the fault reset.</p> <p>0: Only valid for the keypad control</p> <p>1: Both valid for keypad and terminals control</p> <p>2: Both valid for keypad and communication control</p> <p>3: Valid for all control modes</p>	0	○
P07.05	Parameters	0x0000~0xFFFF	0x03FF	○

Function code	Name	Detailed instruction of parameters	Default value	Modify
	state 1	BIT0: running frequency (Hz on) BIT1: set frequency (Hz flickering) BIT2: bus voltage (Hz on) BIT3: output voltage (V on) BIT4: output current (A on) BIT5: running rotation speed (rpm on) BIT6: output power (% on) BIT7: output torque (% on) BIT8: PID reference (% flickering) BIT9: PID feedback value (% on) BIT10: input terminals state BIT11: output terminals state BIT12: torque set value (% on) BIT13: pulse counter value BIT14: length value BIT15: PLC and the current step in multi-step speed		
P07.06	Parameters state 2	0x0000~0xFFFF BIT0: AI1 (V on) BIT1: AI2 (V on) BIT2: AI3 (V on) BIT3: HDI frequency BIT4: motor overload percentage (% on) BIT5: inverter overload percentage (% on) BIT6: ramp frequency reference value (Hz on) BIT7: linear speed BIT8: AC inlet current (A on) BIT9: upper limit frequency (Hz on) BIT10~15: reserved	0x0000	○
P07.07	Parameters for stopping state	0x0000~0xFFFF BIT0: set frequency (Hz on, frequency flickering slowly) BIT1: bus voltage (V on) BIT2: input terminals state	0x00FF	○

Function code	Name	Detailed instruction of parameters	Default value	Modify
		BIT3: output terminals state BIT4: PID reference (% flickering) BIT5: PID feedback value (% on) BIT6: torque set value (% on) BIT7: AI1 (V on) BIT8: AI2 (V on) BIT9: AI3 (V on) BIT10: HDI frequency BIT11: PLC and the current step in multi-step speed BIT12: pulse count value BIT13: length value BIT14: upper limit frequency (Hz on) BIT15: reserved		
P07.08	Frequency coefficient	0.01~10.00 Displayed frequency=running frequency* P07.08	1.00	○
P07.09	Rotation speed coefficient	0.1~999.9% Mechanical rotation speed=120*displayed running frequency×P07.09/motor pole pairs	100.0%	○
P07.10	Linear speed coefficient	0.1~999.9% Linear speed=mechanical rotation speed×P07.10	1.0%	○
P07.11	Rectifier bridge module temperature	-20.0~120.0°C		●
P07.12	Converter module temperature	-20.0~120.0°C		●
P07.13	Software version	1.00~655.35		●
P07.14	Local accumulative running time	0~65535h		●

Function code	Name	Detailed instruction of parameters	Default value	Modify
P07.15	High bit of power consumption	Display the power used by the inverter. Power consumption of the inverter =P07.15*1000+P07.16		●
P07.16	Low bit of power consumption	Setting range of P07.15: 0~65535°(*1000) Setting range of P07.16: 0.0~999.9°		●
P07.17	Reserved	Reserved		●
P07.18	Rated power of the inverter	0.4~3000.0kW		●
P07.19	Rated voltage of the inverter	50~1200V		●
P07.20	Rated current of the inverter	0.1~6000.0A		●
P07.21	Factory bar code 1	0x0000~0xFFFF		●
P07.22	Factory bar code 2	0x0000~0xFFFF		●
P07.23	Factory bar code 3	0x0000~0xFFFF		●
P07.24	Factory bar code 4	0x0000~0xFFFF		●
P07.25	Factory bar code 5	0x0000~0xFFFF		●
P07.26	Factory bar code 6	0x0000~0xFFFF		●

Function code	Name	Detailed instruction of parameters	Default value	Modify
P07.27	Current fault type	0: No fault 1: IGBT U phase protection (OUt1) 2: IGBT V phase protection (OUt2) 3: IGBT W phase protection (OUt3) 4: ACC overcurrent (OC1) 5: DEC overcurrent (OC2) 6: Constant speed overcurrent (OC3) 7: ACC overvoltage (OV1) 8: DEC overvoltage (OV2) 9: Constant speed overvoltage (OV3) 10: Bus undervoltage UV		●
P07.28	Previous fault type	11: Motor overload (OL1) 12: Inverter overload (OL2) 13: Input side phase loss (SPI) 14: Output side phase loss (SPO) 15: Overheat of the rectifier module (OH1) 16: Overheat fault of the converter module (OH2) 17: External fault (EF) 18: 485 communication fault (CE) 19: Current detection fault (ItE) 20: Motor antotuning fault (tE)		●
P07.29	Previous 2 fault type	21: EEPROM operation fault (EEP)		●
P07.30	Previous 3 fault type	22: PID response offline fault (PIDE) 23: Braking unit fault (bCE)		●
P07.31	Previous 4 fault type	24: Running time arrival (END) 25: Electrical overload (OL3)		●
P07.32	Previous 5 fault type	26: Panel communication fault (PCE) 27: Parameter uploading fault (UPE) 28: Parameter downloading fault (DNE) 29: PROFIBUS communication fault (E-DP) 30: Ethernet communication fault (E-NET) 31: CANopen communication fault (E-CAN) 32: Grounding short circuit fault 1 (ETH1)		●

Function code	Name	Detailed instruction of parameters	Default value	Modify
		33: Grounding short circuit fault 2 (ETH2) 34: Speed deviation fault (dEu) 35: Maladjustment (STo) 36: Underload fault (LL)		
P07.33	Running frequency at current fault		0.00Hz	●
P07.34	Ramp reference frequency at current fault		0.00Hz	
P07.35	Output voltage at current fault		0V	
P07.36	Output current at current fault		0.0A	
P07.37	Bus voltage at current fault		0.0V	
P07.38	Max. temperature at current fault		0.0°C	
P07.39	Input terminals state at current fault		0	●
P07.40	Output terminals state at current fault		0	●
P07.41	Running		0.00Hz	●

Function code	Name	Detailed instruction of parameters	Default value	Modify
	frequency at previous fault			
P07.42	Ramp reference frequency at previous fault		0.00Hz	●
P07.43	Output voltage at previous fault		0V	●
P07.44	Output current at previous fault		0.0A	●
P07.45	Bus voltage at previous fault		0.0V	●
P07.46	Max. temperature at previous fault		0.0°C	●
P07.47	Input terminals state at previous fault		0	●
P07.48	Output terminals state at previous fault		0	●

Function code	Name	Detailed instruction of parameters	Default value	Modify
P07.49	Running frequency at previous 2 fault		0.00Hz	●
P07.50	Ramp reference frequency at previous 2 fault		0.00Hz	●
P07.51	Output voltage at previous 2 fault		0V	●
P07.52	Output current at previous 2 fault		0.0A	●
P07.53	Bus voltage at previous 2 fault		0.0V	●
P07.54	Max. temperature at previous 2 fault		0.0°C	●
P07.55	Input terminals state at previous 2 fault		0	●
P07.56	Output terminals state at previous 2 fault		0	●

Function code	Name	Detailed instruction of parameters	Default value	Modify
	fault			
P08 Group Enhanced function				
P08.00	ACC time 2	See P00.11 and P00.12 for detailed definition. Goodrive300-02 series define four groups of ACC/DEC time which can be selected by P5 group. The first group of ACC/DEC time is the factory default one. Setting range: 0.0~3600.0s	Depend on model	<input type="radio"/>
P08.01	DEC time 2		Depend on model	<input type="radio"/>
P08.02	ACC time 3		Depend on model	<input type="radio"/>
P08.03	DEC time 3		Depend on model	<input type="radio"/>
P08.04	ACC time 4		Depend on model	<input type="radio"/>
P08.05	DEC time 4		Depend on model	<input type="radio"/>
P08.06	Jogging frequency	This parameter is used to define the reference frequency during jogging. Setting range: 0.00Hz ~P00.03	5.00Hz	<input type="radio"/>
P08.07	Jogging ACC time	The jogging ACC time means the time needed if the inverter runs from 0Hz to the Max. frequency.	Depend on model	<input type="radio"/>
P08.08	Jogging DEC time	The jogging DEC time means the time needed if the inverter goes from the Max. frequency (P0.03) to 0Hz. Setting range: 0.0~3600.0s	Depend on model	<input type="radio"/>
P08.09	Jumping frequency 1	When the set frequency is in the range of jumping frequency, the inverter will run at the edge of the jumping frequency.	0.00Hz	<input type="radio"/>
P08.10	Jumping frequency	The inverter can avoid the mechanical resonance	0.00Hz	<input type="radio"/>

Function code	Name	Detailed instruction of parameters	Default value	Modify	
	range 1	point by setting the jumping frequency. The inverter			
P08.11	Jumping frequency 2	can set three jumping frequency. But this function will be invalid if all jumping points are 0.	0.00Hz	<input type="radio"/>	
P08.12	Jumping frequency range 2		0.00Hz	<input type="radio"/>	
P08.13	Jumping frequency 3		0.00Hz	<input type="radio"/>	
P08.14	Jumping frequency range 3		Setting range: 0.00Hz~P00.03	0.00Hz	<input type="radio"/>
P08.15	Traverse range		This function applies to the industries where traverse and convolution function are required such as textile and chemical fiber.	0.0%	<input type="radio"/>
P08.16	Sudden jumping frequency range	The traverse function means that the output frequency of the inverter is fluctuated with the set frequency as its center. The route of the running frequency is illustrated as below, of which the traverse is set by P08.15 and when P08.15 is set as	0.0%	<input type="radio"/>	
P08.17	Traverse boost time	0, the traverse is 0 with no function.	5.0s	<input type="radio"/>	
P08.18	Traverse declining time	<p>Traverse range: The traverse running is limited by upper and low frequency.</p> <p>The traverse range relative to the center frequency: $\text{traverse range AW} = \text{center frequency} \times \text{traverse range P08.15}$</p> <p>Sudden jumping frequency=$\text{traverse range AW} \times \text{sudden jumping frequency range P08.16}$. When run</p>	5.0s	<input type="radio"/>	

Function code	Name	Detailed instruction of parameters	Default value	Modify
		<p>at the traverse frequency, the value which is relative to the sudden jumping frequency.</p> <p>The raising time of the traverse frequency: The time from the lowest point to the highest one.</p> <p>The declining time of the traverse frequency: The time from the highest point to the lowest one.</p> <p>The setting range of P08.15: 0.0~100.0%(relative to the set frequency)</p> <p>The setting range of P08.16: 0.0~50.0%(relative to the traverse range)</p> <p>The setting range of P08.17: 0.1~3600.0s</p> <p>The setting range of P08.18: 0.1~3600.0s</p>		
P08.19	Setting length	The function codes of setting length, actual length and unit pulse are mainly used to control the fixed	0m	<input type="radio"/>
P08.20	Actual length	length. The length is counted by the pulse signal of HDI	0m	<input checked="" type="radio"/>
P08.21	Pulse per rotation	terminals input and the HDI terminals are needed to set as the length counting input.	1	<input type="radio"/>
P08.22	Axle perimeter	Actual length=the length counting input pulse/unit pulse	10.00cm	<input type="radio"/>
P08.23	Length ratio	When the actual length P08.20 exceeds the setting length P08.19, the multi-function digital output terminals will output ON.	1.000	<input type="radio"/>
P08.24	Length correcting coefficient	<p>Setting range of P08.19: 0~65535m</p> <p>Setting range of P08.20: 0~65535m</p> <p>Setting range of P08.21: 1~10000</p> <p>Setting range of P08.22: 0.01~100.00cm</p> <p>Setting range of P08.23: 0.001~10.000</p> <p>Setting range of P08.24: 0.001~1.000</p>	1.000	<input type="radio"/>
P08.25	Setting count value	The counter works by the input pulse signals of the HDI terminals.	0	<input type="radio"/>
P08.26	Reference count value	When the counter achieves a fixed number, the multi-function output terminals will output the signal of	0	<input type="radio"/>

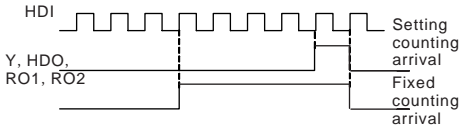
Function code	Name	Detailed instruction of parameters	Default value	Modify
		<p>“fixed counting number arrival” and the counter go on working; when the counter achieves a setting number, the multi-function output terminals will output the signal of “setting counting number arrival”, the counter will clear all numbers and stop to recount before the next pulse.</p> <p>The setting count value P08.26 should be no more than the setting count value P08.25.</p> <p>The function is illustrated as below:</p>  <p>Setting range of P08.25: P08.26~65535 Setting range of P08.26: 0~P08.25</p>		
P08.27	Set running time	<p>Pre-set running time of the inverter. When the accumulative running time achieves the set time, the multi-function digital output terminals will output the signal of “running time arrival”.</p> <p>Setting range: 0~65535min</p>	0min	○
P08.28	Fault reset times	<p>Fault reset times: set the automatic fault reset times. If the reset time exceeds this set value, the inverter will stop to wait maintenance.</p>	0	○
P08.29	Interval time of automatic fault reset	<p>Interval time of automatic fault reset: the interval between the time when the fault occurs and the time when the reset action occurs.</p> <p>After the inverter runs, if no fault in 60s, P08.28 will clear.</p> <p>Setting range of P08.28: 0~10 Setting range of P08.29: 0.1~3600.0s</p>	1.0s	○
P08.30	Frequency decreasing ratio of	<p>The output frequency of the inverter changes as the load. And it is mainly used to balance the power when several inverters drive one load.</p>	0.00Hz	○

Function code	Name	Detailed instruction of parameters	Default value	Modify
	dropping control	Setting range: 0.00~50.00Hz		
P08.31	Motor shifting	<p>Goodrive300-02 series supports the shift between two motors. This function is used to select the shifting channel.</p> <p>LED ones: shifting channel</p> <p>0: terminal shifting; digital terminal is 35</p> <p>1: MODBUS communication shifting</p> <p>2: PROFIBUS/CANopen communication shifting</p> <p>3: Ethernet communication shifting</p> <p>4: Reserved</p> <p>LED tens: shifting enabling in operation</p> <p>0: Disabled</p> <p>1: Enabled</p> <p>0x00~0x14</p>	0x00	☉
P08.32	FDT1 electrical level detection value	<p>When the output frequency exceeds the corresponding frequency of FDT electrical level, the multi-function digital output terminals will output the signal of "frequency level detect FDT" until the output frequency decreases to a value lower than (FDT electrical level-FDT retention detection value) the corresponding frequency, the signal is invalid. Below is the waveform diagram:</p> <p>Setting range of P08.32: 0.00Hz~P00.03 (Max. output</p>	50.00Hz	○
P08.33	FDT1 retention detection value		5.0%	○
P08.34	FDT2 electrical level detection value		50.00Hz	○
P08.35	FDT2 retention detection value		5.0%	○

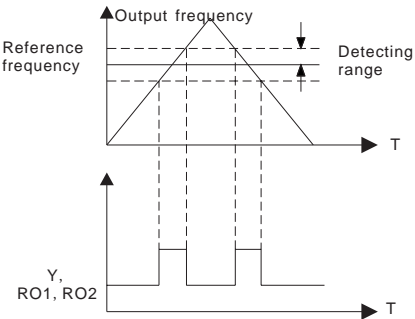
Function code	Name	Detailed instruction of parameters	Default value	Modify
		frequency) Setting range of P08.33: 0.0~100.0% (FDT1 electrical level) Setting range of P08.34: 0.00Hz~P00.03 (Max. output frequency) Setting range of P08.35: 0.0~100.0% (FDT2 electrical level)		
P08.36	Frequency arrival detection value	When the output frequency is among the positive or negative detection range of the set frequency, the multi-function digital output terminal will output the signal of "frequency arrival", see the diagram below for detailed information:  The setting range: 0.00Hz~P00.03 (Max. output frequency)	0.00Hz	○
P08.37	Energy braking enable	This parameter is used to control the internal braking pipe inside the inverter. 0: Disable 1: Enable Note: Only apply to internal braking pipe.	0	○
P08.38	Threshold voltage	After setting the original bus voltage to brake the energy, adjust the voltage appropriately to brake the load. The factory changes with the voltage level. The setting range: 200.0~2000.0V	380V voltage: 700.0V 500V voltage:	○

Function code	Name	Detailed instruction of parameters	Default value	Modify
			900.0V	
			660V voltage: 1120.0V	
P08.39	Cooling fan running mode	0: Normal mode 1: The fan keeps running after power on	0	○
P08.40	PWM selection	0x00~0x21 LED ones: PWM mode selection 0: PWM mode 1, three-phase modulation and two-phase modulation 1: PWM mode 2, three-phase modulation LED tens: low-speed carrier frequency limit mode 0: Low-speed carrier frequency limit mode 1, the carrier frequency will limit to 2k if it exceeds 2k at low speed 1: Low-speed carrier frequency limit mode 2, the carrier frequency will limit to 4k if it exceeds 4k at low speed 2: No limit	01	◎
P08.41	Over commission selection	LED ones 0: Invalid 1: Valid LED tens 0: Light overcommission; in zone 1 1: Heavy overcommission; in zone 2	01	◎
P08.42	Keypad data control	0x000~0x1223 LED ones: frequency enable selection 0: Both \wedge/\vee key and digital potentiometer adjustment are valid 1: Only \wedge/\vee key adjustment is valid 2: Only digital potentiometer adjustment is valid	0x0000	○

Function code	Name	Detailed instruction of parameters	Default value	Modify
		<p>3: Neither \wedge/\vee key nor digital potentiometer adjustment is valid</p> <p>LED tens: frequency control selection</p> <p>0: Only valid when P00.06=0 or P00.07=0</p> <p>1: Valid for all frequency setting manner</p> <p>2: Invalid for multi-step speed when multi-step speed has the priority</p> <p>LED hundreds: action selection during stopping</p> <p>0: Setting is valid</p> <p>1: Valid during running, clear after stopping</p> <p>2: Valid during running, clear after receiving the stop command</p> <p>LED thousands: \wedge/\vee key and digital potentiometer integral function</p> <p>0: The integral function is valid</p> <p>1: The integral function is invalid</p>		
P08.43	Integral ratio of keypad potentiometer	0.01~10.00s	0.10s	○
P08.44	UP/DOWN terminals control	<p>0x000~0x221</p> <p>LED ones: frequency enable selection</p> <p>0: UP/DOWN terminals setting is valid</p> <p>1: UP/DOWN terminals setting is invalid</p> <p>LED tens: frequency control selection</p> <p>0: Only valid when P00.06=0 or P00.07=0</p> <p>1: All frequency means are valid</p> <p>2: When the multi-step speed has the priority, it is invalid to the multi-step speed</p> <p>LED hundreds: action selection during stopping</p> <p>0: Setting is valid</p> <p>1: Valid during running, clear after stop</p> <p>2: Valid during running, clear after receiving the stop command</p>	0x000	○

Function code	Name	Detailed instruction of parameters	Default value	Modify
P08.45	UP terminals frequency changing ratio	0.01~50.00Hz/s	0.50Hz/s	<input type="radio"/>
P08.46	DOWN terminals frequency changing ratio	0.01~50.00Hz/s	0.50Hz/s	<input type="radio"/>
P08.47	Frequency setting at power loss	0x000~0x111 LED ones: Action selection when power off. 0: Save when power off 1: Clear when power off LED tens: Action selection when MODBUS set frequency off 0: Save when power off 1: Clear when power off LED hundreds: The action selection when other communication set frequency off 0: Save when power off 1: Clear when power off	0x000	<input type="radio"/>
P08.48	High bit of initial power consumption	This parameter is used to set the original value of the power consumption. Original value of power consumption	0°	<input type="radio"/>
P08.49	Low bit of initial power consumption	=P08.48*1000+P08.49 Setting range of P08.48: 0~59999°(k) Setting range of P08.49: 0.0~999.9°	0.0°	<input type="radio"/>
P08.50	Magnetic flux braking	This function code is used to enable magnetic flux. 0: Invalid. 100~150: The bigger the coefficient, the stronger the braking is. This inverter is used to increase the magnetic flux to	0	<input type="radio"/>

Function code	Name	Detailed instruction of parameters	Default value	Modify
		<p>decelerate the motor. The energy generated by the motor during braking can be converted into heat energy by increasing the magnetic flux.</p> <p>The inverter monitors the state of the motor continuously even during the magnetic flux period. So the magnetic flux can be used in the motor stop, as well as to change the rotation speed of the motor. Its other advantages are:</p> <p>Brake immediately after the stop command. It does not need to wait the magnetic flux weaken.</p> <p>Better cooling for motors. The current of the stator other than the rotor increases during magnetic flux braking, while the cooling of the stator is more effective than the rotor.</p>		
P08.51	Input power factor of the inverter	<p>This function code is used to adjust the displayed current of the AC input side.</p> <p>Setting range: 0.00~1.00</p>	0.56	<input type="radio"/>
P09 Group PID control				
P09.00	PID reference source	<p>When the frequency command selection (P00.06, P00.07) is 7 or the voltage setting channel selection (P04.27) is 6, the running mode of the inverter is procedure PID controlled.</p> <p>The parameter determines the target reference channel during the PID procedures.</p> <p>0: Keypad (P09.01)</p> <p>1: AI1</p> <p>2: AI2</p> <p>3: AI3</p> <p>4: HDI</p> <p>5: Multi-step speed set</p> <p>6: MODBUS communication set</p> <p>7: PROFIBUS/CANopen communication set</p> <p>8: Ethernet communication set</p>	0	<input type="radio"/>

Function code	Name	Detailed instruction of parameters	Default value	Modify
		<p>9: Reserved</p> <p>The setting target of procedure PID is a relative one, 100% of the setting equals to 100% of the response of the controlled system.</p> <p>The system is calculated according to the relative value (0~100.0%).</p> <p>Note: Multi-step speed reference, it is realized by setting P10 group parameters.</p> <p>PROFIBUS, Ethernet and CANopen communication setting need corresponding extension cards.</p>		
P09.01	Keypad PID preset	<p>When P09.00=0, set the parameter whose basic value is the response value of the system.</p> <p>The setting range: -100.0%~100.0%</p>	0.0%	<input type="radio"/>
P09.02	PID feedback source	<p>Select the PID channel by the parameter.</p> <p>0: AI1 1: AI2 2: AI3 3: HDI 4: MODBUS communication feedback 5: PROFIBUS/CANopen communication feedback 6: Ethernet communication feedback 7: Reserved</p> <p>Note: The reference and feedback channel cannot coincide, otherwise, PID cannot control effectively.</p>	0	<input type="radio"/>
P09.03	PID output feature	<p>0: PID output is positive: when the feedback signal exceeds the PID reference, the output frequency of the inverter will decrease to balance the PID. For example, the strain PID control during wrapup</p> <p>1: PID output is negative: When the feedback signal is stronger than the PID reference, the output frequency of the inverter will increase to balance the PID. For example, the strain PID control during wrapdown</p>	0	<input type="radio"/>
P09.04	Proportional	The function is applied to the proportional gain P of	1.00	<input type="radio"/>

Function code	Name	Detailed instruction of parameters	Default value	Modify
	gain (Kp)	PID input. P determines the strength of the whole PID adjuster. The parameter of 100 means that when the offset of PID feedback and reference value is 100%, the adjusting range of PID adjuster is the Max. frequency (ignoring integral and differential function). The setting range: 0.00~100.00		
P09.05	Integral time(Ti)	This parameter determines the speed of PID adjuster to carry out integral adjustment on the deviation of PID feedback and reference. When the deviation of PID feedback and reference is 100%, the integral adjuster works continuously after the time (ignoring the proportional effect and differential effect) to achieve the Max. Frequency (P00.03) or the Max. Voltage (P04.31). Shorter the integral time, stronger is the adjustment Setting range: 0.00~10.00s	0.10s	○
P09.06	Differential time(Td)	This parameter determines the strength of the change ratio when PID adjuster carries out integral adjustment on the deviation of PID feedback and reference. If the PID feedback changes 100% during the time, the adjustment of integral adjuster (ignoring the proportional effect and differential effect) is the Max. Frequency (P00.03) or the Max. Voltage (P04.31). Longer the integral time, stronger is the adjusting. Setting range: 0.00~10.00s	0.00s	○
P09.07	Sampling cycle(T)	This parameter means the sampling cycle of the feedback. The adjuster operates each sampling cycle. The longer the sapling cycle is, the slower the response is. Setting range: 0.000~10.000s	0.100s	○
P09.08	PID control	The output of PID system is the maximum deviation	0.0%	○

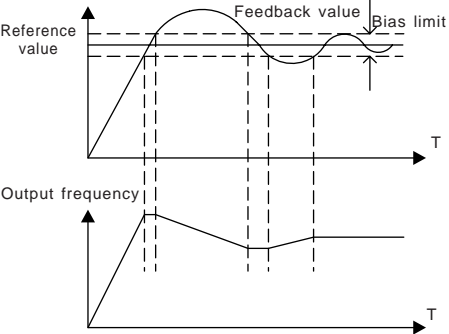
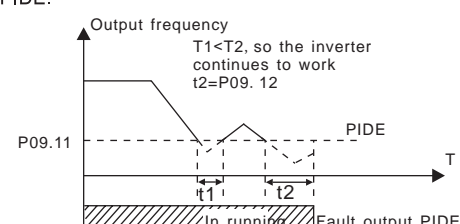
Function code	Name	Detailed instruction of parameters	Default value	Modify
	deviation limit	<p>relative to close loop reference. As shown in the diagram below, PID adjustor stops to work during the deviation limit. Set the function properly to adjust the accuracy and stability of the system.</p>  <p>Setting range: 0.0~100.0%</p>		
P09.09	Output upper limit of PID	<p>This parameter is used to set the upper and lower limit of the PID adjustor output.</p> <p>100.0 % corresponds to max. frequency or the max. voltage of (P04.31)</p>	100.0%	<input type="radio"/>
P09.10	Output lower limit of PID	<p>Setting range of P09.09: P09.10~100.0%</p> <p>Setting range of P09.10: -100.0%~P09.09</p>	0.0%	<input type="radio"/>
P09.11	Detection value of feedback offline	<p>Set the detection value of feedback offline, when the feedback detection value is smaller than or equals to the detected value, and the lasting time exceeds the set value in P09.12, the inverter will report "PID feedback offline fault" and the keypad will display PIDE.</p>	0.0%	<input type="radio"/>
P09.12	Detection time of feedback offline	 <p>Setting range of P09.11: 0.0~100.0%</p>	1.0s	<input type="radio"/>

Function code	Name	Detailed instruction of parameters	Default value	Modify
		Setting range of P09.12: 0.0~3600.0s		
P09.13	PID adjustment	0x0000~0x1111 LED ones: 0: Keep on integral adjustment when the frequency achieves the upper and low limit; the integration shows the change between the reference and the feedback unless it reaches the internal integral limit. When the trend between the reference and the feedback changes, it needs more time to offset the impact of continuous working and the integration will change with the trend. 1: Stop integral adjustment when the frequency achieves the upper and low limit. If the integration keeps stable, and the trend between the reference and the feedback changes, the integration will change with the trend quickly. LED tens: 0: The same with the setting direction; if the output of PID adjustment is different from the current running direction, the internal will output 0 forcedly. 1: Opposite to the setting direction; if the output of PID adjustment is different from the current running direction, carry out close loop adjustment output which is opposite to the current setting direction. LED hundreds: 0: According to the Max. frequency limiting 1: According to A frequency limiting LED thousands: 0: A+B frequency, buffer ACC/DEC for main reference A frequency source is invalid 1: A+B frequency, buffer ACC/DEC for main reference A frequency source is valid and ACC/DEC is decided by P08.04.	0x0001	○

Function code	Name	Detailed instruction of parameters	Default value	Modify
P09.14	Low frequency proportional gain (Kp)	0.00~100.00	1.00	<input type="radio"/>
P09.15	PID command ACC/DEC time	0.0~1000.0s	0.0s	<input type="radio"/>
P09.16	PID output filter time	0.000~10.000s	0.000s	<input type="radio"/>
P10 Group Multi-step speed control				
P10.00	Simple PLC	0: Stop after running once. The inverter has to be commanded again after finishing a cycle. 1: Run at the final value after running once. After finish a signal, the inverter will keep the running frequency and direction of the last run. 2: Cycle running. The inverter will keep on running until receiving a stop command d. And then, the system will stop.	0	<input type="radio"/>
P10.01	Simple PLC memory	0: Power loss without memory 1: Power loss memory; PLC record the running stage and frequency when power loss.	0	<input type="radio"/>
P10.02	Multi-step speed 0	The frequency setting range of stage 0~15: -100.0~100.0%, 100.0% of the frequency setting	0.0%	<input type="radio"/>
P10.03	The running time of step 0	corresponds to the Max. frequency P00.03. The operation time setting of stage 0~15:	0.0s	<input type="radio"/>
P10.04	Multi-step speed 1	0.0~6553.5s(min), the time unit is determined by P10.37. When selecting simple PLC running, set	0.0%	<input type="radio"/>
P10.05	The running time of step 1	P10.02~P10.33 to define the running frequency and time of all stages.	0.0s	<input type="radio"/>
P10.06	Multi-step speed 2	Note: The symbol of multi-step determines the running direction of simple PLC. The negative value	0.0%	<input type="radio"/>
P10.07	The running	means reverse rotation.	0.0s	<input type="radio"/>

Function code	Name	Detailed instruction of parameters	Default value	Modify
	time of step 2			
P10.08	Multi-step speed 3		0.0%	<input type="radio"/>
P10.09	The running time of step 3		0.0s	<input type="radio"/>
P10.10	Multi-step speed 4	If multi-step speed operation is selected, multi-step	0.0%	<input type="radio"/>
P10.11	The running time of step 4	speeds are in the range of $-f_{max} \sim f_{max}$ and it can be set continuously. The start-up and stop during multi-step speed is decided by P00.01.	0.0s	<input type="radio"/>
P10.12	Multi-step speed 5	Goodrive300-02 series inverters can set 16 stages	0.0%	<input type="radio"/>
P10.13	The running time of step 5	speed, selected by the combination of multi-step terminals 1~4 (select the setting by S terminals, the corresponding function codes are P05.01~P05.09),	0.0s	<input type="radio"/>
P10.14	Multi-step speed 6	corresponding to the speed 0 to speed 15.	0.0%	<input type="radio"/>
P10.15	The running time of step 6		0.0s	<input type="radio"/>
P10.16	Multi-step speed 7		0.0%	<input type="radio"/>
P10.17	The running time of step 7		0.0s	<input type="radio"/>
P10.18	Multi-step speed 8		0.0%	<input type="radio"/>
P10.19	The running time of step 8	When terminal 1, terminal 2, terminal 3, terminal 4=OFF, the frequency input manner is selected via	0.0s	<input type="radio"/>
P10.20	Multi-step speed 9	code P00.06 or P00.07. When not all terminal 1, terminal 2, terminal 3, terminal 4 are off, it runs at	0.0%	<input type="radio"/>
P10.21	The running time of step 9	multi-step which takes precedence of keypad, analog value, high-speed pulse, PID, communication	0.0s	<input type="radio"/>
P10.22	Multi-step speed 10	frequency setting.	0.0%	<input type="radio"/>
P10.23	The running	The relationship between terminal 1, terminal 2,	0.0s	<input type="radio"/>

Function code	Name	Detailed instruction of parameters	Default value	Modify																											
	time of step 10	terminal 3, terminal 4 and multi-step speed is as following:																													
P10.24	Multi-step speed 11	<table border="1"> <tr> <td>Terminal 1</td> <td>OFF</td> <td>ON</td> <td>OFF</td> <td>ON</td> <td>OFF</td> <td>ON</td> <td>OFF</td> <td>ON</td> </tr> <tr> <td>Terminal 2</td> <td>OFF</td> <td>OFF</td> <td>ON</td> <td>ON</td> <td>OFF</td> <td>OFF</td> <td>ON</td> <td>ON</td> </tr> </table>	Terminal 1	OFF	ON	OFF	ON	OFF	ON	OFF	ON	Terminal 2	OFF	OFF	ON	ON	OFF	OFF	ON	ON	0.0%	<input type="radio"/>									
Terminal 1	OFF	ON	OFF	ON	OFF	ON	OFF	ON																							
Terminal 2	OFF	OFF	ON	ON	OFF	OFF	ON	ON																							
P10.25	The running time of step 11	<table border="1"> <tr> <td>Terminal 3</td> <td>OFF</td> <td>OFF</td> <td>OFF</td> <td>OFF</td> <td>ON</td> <td>ON</td> <td>ON</td> <td>ON</td> </tr> <tr> <td>Terminal 4</td> <td>OFF</td> <td>OFF</td> <td>OFF</td> <td>OFF</td> <td>OFF</td> <td>OFF</td> <td>OFF</td> <td>OFF</td> </tr> <tr> <td>Step</td> <td>0</td> <td>1</td> <td>2</td> <td>3</td> <td>4</td> <td>5</td> <td>6</td> <td>7</td> </tr> </table>	Terminal 3	OFF	OFF	OFF	OFF	ON	ON	ON	ON	Terminal 4	OFF	OFF	OFF	OFF	OFF	OFF	OFF	OFF	Step	0	1	2	3	4	5	6	7	0.0s	<input type="radio"/>
Terminal 3	OFF	OFF	OFF	OFF	ON	ON	ON	ON																							
Terminal 4	OFF	OFF	OFF	OFF	OFF	OFF	OFF	OFF																							
Step	0	1	2	3	4	5	6	7																							
P10.26	Multi-step speed 12	<table border="1"> <tr> <td>Terminal 1</td> <td>OFF</td> <td>ON</td> <td>OFF</td> <td>ON</td> <td>OFF</td> <td>ON</td> <td>OFF</td> <td>ON</td> </tr> <tr> <td>Terminal 2</td> <td>OFF</td> <td>OFF</td> <td>ON</td> <td>ON</td> <td>OFF</td> <td>OFF</td> <td>ON</td> <td>ON</td> </tr> </table>	Terminal 1	OFF	ON	OFF	ON	OFF	ON	OFF	ON	Terminal 2	OFF	OFF	ON	ON	OFF	OFF	ON	ON	0.0%	<input type="radio"/>									
Terminal 1	OFF	ON	OFF	ON	OFF	ON	OFF	ON																							
Terminal 2	OFF	OFF	ON	ON	OFF	OFF	ON	ON																							
P10.27	The running time of step 12	<table border="1"> <tr> <td>Terminal 3</td> <td>OFF</td> <td>OFF</td> <td>OFF</td> <td>OFF</td> <td>ON</td> <td>ON</td> <td>ON</td> <td>ON</td> </tr> <tr> <td>Terminal 4</td> <td>ON</td> <td>ON</td> <td>ON</td> <td>ON</td> <td>ON</td> <td>ON</td> <td>ON</td> <td>ON</td> </tr> <tr> <td>Step</td> <td>8</td> <td>9</td> <td>10</td> <td>11</td> <td>12</td> <td>13</td> <td>14</td> <td>15</td> </tr> </table>	Terminal 3	OFF	OFF	OFF	OFF	ON	ON	ON	ON	Terminal 4	ON	ON	ON	ON	ON	ON	ON	ON	Step	8	9	10	11	12	13	14	15	0.0s	<input type="radio"/>
Terminal 3	OFF	OFF	OFF	OFF	ON	ON	ON	ON																							
Terminal 4	ON	ON	ON	ON	ON	ON	ON	ON																							
Step	8	9	10	11	12	13	14	15																							
P10.28	Multi-step speed 13		0.0%	<input type="radio"/>																											
P10.29	The running time of step 13		0.0s	<input type="radio"/>																											
P10.30	Multi-step speed 14		0.0%	<input type="radio"/>																											
P10.31	The running time of step 14		0.0s	<input type="radio"/>																											
P10.32	Multi-step speed 15		0.0%	<input type="radio"/>																											
P10.33	The running time of step 15		0.0s	<input type="radio"/>																											
P10.34	Simple PLC 0~7 step ACC/DEC time	<p>Below is the detailed instruction:</p> <table border="1"> <thead> <tr> <th>Function code</th> <th colspan="2">Binary bit</th> <th>Step</th> <th>ACC/DEC 1</th> <th>ACC/DEC 2</th> <th>ACC/DEC 3</th> <th>ACC/DEC 4</th> </tr> </thead> <tbody> <tr> <td rowspan="2">P10.34</td> <td>BIT1</td> <td>BIT0</td> <td>0</td> <td>00</td> <td>01</td> <td>10</td> <td>11</td> </tr> <tr> <td>BIT3</td> <td>BIT2</td> <td>1</td> <td>00</td> <td>01</td> <td>10</td> <td>11</td> </tr> </tbody> </table>	Function code	Binary bit		Step	ACC/DEC 1	ACC/DEC 2	ACC/DEC 3	ACC/DEC 4	P10.34	BIT1	BIT0	0	00	01	10	11	BIT3	BIT2	1	00	01	10	11	0x0000	<input type="radio"/>				
Function code	Binary bit		Step	ACC/DEC 1	ACC/DEC 2	ACC/DEC 3	ACC/DEC 4																								
P10.34	BIT1	BIT0	0	00	01	10	11																								
	BIT3	BIT2	1	00	01	10	11																								
P10.35	Simple PLC 8~15 step		0x0000	<input type="radio"/>																											

Function code	Name	Detailed instruction of parameters	Default value	Modify																																																																																																		
	ACC/DEC time	<table border="1"> <tr> <td>BIT3</td> <td>BIT4</td> <td>2</td> <td>00</td> <td>01</td> <td>10</td> <td>11</td> </tr> <tr> <td>BIT7</td> <td>BIT6</td> <td>3</td> <td>00</td> <td>01</td> <td>10</td> <td>11</td> </tr> <tr> <td>BIT9</td> <td>BIT8</td> <td>4</td> <td>00</td> <td>01</td> <td>10</td> <td>11</td> </tr> <tr> <td>BIT11</td> <td>BIT10</td> <td>5</td> <td>00</td> <td>01</td> <td>10</td> <td>11</td> </tr> <tr> <td>BIT13</td> <td>BIT12</td> <td>6</td> <td>00</td> <td>01</td> <td>10</td> <td>11</td> </tr> <tr> <td>BIT15</td> <td>BIT14</td> <td>7</td> <td>00</td> <td>01</td> <td>10</td> <td>11</td> </tr> <tr> <td>BIT1</td> <td>BIT0</td> <td>8</td> <td>00</td> <td>01</td> <td>10</td> <td>11</td> </tr> <tr> <td>BIT3</td> <td>BIT2</td> <td>9</td> <td>00</td> <td>01</td> <td>10</td> <td>11</td> </tr> <tr> <td>BIT5</td> <td>BIT4</td> <td>10</td> <td>00</td> <td>01</td> <td>10</td> <td>11</td> </tr> <tr> <td>BIT7</td> <td>BIT6</td> <td>11</td> <td>00</td> <td>01</td> <td>10</td> <td>11</td> </tr> <tr> <td>BIT9</td> <td>BIT8</td> <td>12</td> <td>00</td> <td>01</td> <td>10</td> <td>11</td> </tr> <tr> <td>BIT11</td> <td>BIT10</td> <td>13</td> <td>00</td> <td>01</td> <td>10</td> <td>11</td> </tr> <tr> <td>BIT13</td> <td>BIT12</td> <td>14</td> <td>00</td> <td>01</td> <td>10</td> <td>11</td> </tr> <tr> <td>BIT15</td> <td>BIT14</td> <td>15</td> <td>00</td> <td>01</td> <td>10</td> <td>11</td> </tr> </table> <p>P10.35</p> <p>After users select the corresponding ACC/DEC time, the combining 16 binary bit can be changed into hexadecimal bit, and then set the corresponding function codes.</p> <p>ACC/DEC time 1 is set by P00.11 and P00.12; ACC/DEC time 2 is set by P08.00 and P08.01; ACC/DEC time 3 is set by P08.02 and P08.03; ACC/DEC time 4 is set by P08.04 and P08.05.</p> <p>Setting range: -0x0000~0xFFFF</p>	BIT3	BIT4	2	00	01	10	11	BIT7	BIT6	3	00	01	10	11	BIT9	BIT8	4	00	01	10	11	BIT11	BIT10	5	00	01	10	11	BIT13	BIT12	6	00	01	10	11	BIT15	BIT14	7	00	01	10	11	BIT1	BIT0	8	00	01	10	11	BIT3	BIT2	9	00	01	10	11	BIT5	BIT4	10	00	01	10	11	BIT7	BIT6	11	00	01	10	11	BIT9	BIT8	12	00	01	10	11	BIT11	BIT10	13	00	01	10	11	BIT13	BIT12	14	00	01	10	11	BIT15	BIT14	15	00	01	10	11		
BIT3	BIT4	2	00	01	10	11																																																																																																
BIT7	BIT6	3	00	01	10	11																																																																																																
BIT9	BIT8	4	00	01	10	11																																																																																																
BIT11	BIT10	5	00	01	10	11																																																																																																
BIT13	BIT12	6	00	01	10	11																																																																																																
BIT15	BIT14	7	00	01	10	11																																																																																																
BIT1	BIT0	8	00	01	10	11																																																																																																
BIT3	BIT2	9	00	01	10	11																																																																																																
BIT5	BIT4	10	00	01	10	11																																																																																																
BIT7	BIT6	11	00	01	10	11																																																																																																
BIT9	BIT8	12	00	01	10	11																																																																																																
BIT11	BIT10	13	00	01	10	11																																																																																																
BIT13	BIT12	14	00	01	10	11																																																																																																
BIT15	BIT14	15	00	01	10	11																																																																																																
P10.36	PLC restart	<p>0: Restart from the first step; stop during running (cause by the stop command, fault or power loss), run from the first stage after restart.</p> <p>1: Continue to run from the stop frequency; stop during running(cause by stop command and fault), the inverter will record the running time automatically, enter into the stage after restart and keep the remaining running at the setting frequency.</p>	0	☉																																																																																																		
P10.37	Multi-step time unit	0: Seconds; the running time of all steps is counted by second	0	☉																																																																																																		

Function code	Name	Detailed instruction of parameters	Default value	Modify								
		1: Minutes; the running time of all steps is counted by minute										
P11 Group Protective parameters												
P11.00	Phase loss protection	0x00~0x11 LED ones: 0: Input phase loss protection disable 1: Input phase loss protection enable LED tens: 0: Input phase loss protection disable 1: Input phase loss protection enable	11	<input type="radio"/>								
P11.01	Frequency decreasing at sudden power loss	0: Disable 1: Enable	0	<input type="radio"/>								
P11.02	Frequency decreasing ratio at sudden power loss	Setting range: 0.00Hz/s~P00.03 After the power loss of the grid, the bus voltage drops to the sudden frequency decreasing point, the inverter begins to decrease the running frequency at P11.02 to make the inverter generate power again. The returning power can maintain the bus voltage to ensure a rated running of the inverter until the recovery of power. <table border="1" style="margin-left: auto; margin-right: auto;"> <tr> <td>Voltage degree</td> <td>380V</td> <td>500V</td> <td>660V</td> </tr> <tr> <td>Frequency decreasing threshold</td> <td>460V</td> <td>580V</td> <td>800V</td> </tr> </table> <p>Note: 1. Adjust the parameter properly to avoid the stopping caused by inverter protection during the switching of the grid. 2. Prohibition of input phase protection can enable this function.</p>	Voltage degree	380V	500V	660V	Frequency decreasing threshold	460V	580V	800V	10.00Hz/s	<input type="radio"/>
Voltage degree	380V	500V	660V									
Frequency decreasing threshold	460V	580V	800V									
P11.03	Overvoltage	0: Disable	1	<input type="radio"/>								

Function code	Name	Detailed instruction of parameters	Default value	Modify
	stall protection	1: Enable 		
P11.04	Voltage	120~150% (standard bus voltage) (380V)	140%	○
	protection of overvoltage	120~150% (standard bus voltage) (500V)	132%	
	stall	120~150% (standard bus voltage) (660V)	120%	
P11.05	Current limit action selection	The actual increasing ratio of motor speed is lower than the ratio of output frequency because of the big load during ACC running. It is necessary to take measures to avoid overcurrent fault and the inverter trips. Ones: current limit 0: Invalid 1: Valid Tens: overload alarm of hardware current limit 0: Valid 1: Invalid	01	◎
P11.06	Automatic current limit	During the running of the inverter, it will detect the output current and compare it with the limit level defined in P11.06. If it exceeds the level, the inverter will run at stable frequency in ACC running, or the inverter will derate to run during the constant running.	160.0%	◎
P11.07	Frequency decreasing ratio during current limit	If it exceeds the level continuously, the output frequency will keep on decreasing to the lower limit. If the output current is detected to be lower than the limit level, the inverter will accelerate to run.	10.00Hz/s	◎

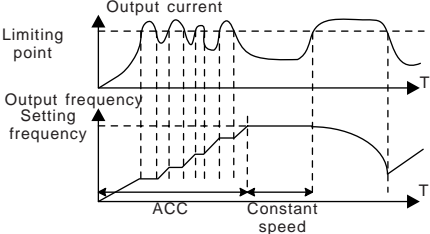
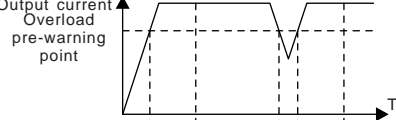
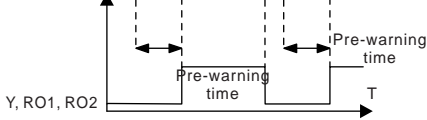
Function code	Name	Detailed instruction of parameters	Default value	Modify
		 <p>Setting range of P11.06: 50.0~200.0%</p> <p>Setting range of P11.07: 0.00~50.00Hz/s</p>		
P11.08	Overload pre-alarm of motor/inverter	<p>The output current of the inverter or the motor is above P11.09 and the lasting time is beyond P11.10, overload pre-alarm will be output.</p>	0x000	○
P11.09	Overload pre-alarm detection		150%	○
P11.10	Overload pre-alarm detection time	 <p>Setting range of P11.08: Enable and define the overload pre-alarm of the inverter or the motor. Setting range: 0x000~0x131</p> <p>LED ones: 0: Overload pre-alarm of the motor, relative to the rated current of the motor 1: Overload pre-alarm of the inverter, relative to the rated current of the inverter</p> <p>LED tens: 0: The inverter continues to work after underload pre-alarm 1: The inverter continues to work after underload</p>	1.0s	○

Function code	Name	Detailed instruction of parameters	Default value	Modify
		<p>pre-alarm and the inverter stops running after overload fault</p> <p>2: The inverter continues to work after overload pre-alarm and the inverter stops running after underload fault</p> <p>3: The inverter stops running after overload/underload fault</p> <p>LED hundreds :</p> <p>0: Detection all the time</p> <p>1: Detection in constant running</p> <p>Setting range of P11.09: P11.11~200%</p> <p>Setting range of P11.10: 0.1~3600.0s</p>		
P11.11	Underload pre-alarm detection	<p>If the inverter current or the output current is lower than P11.11, and its lasting time is beyond P11.12, the inverter will output underload pre-alarm.</p> <p>Setting range of P11.11: 0~P11.09</p> <p>Setting range of P11.12: 0.1~3600.0s</p>	50%	<input type="radio"/>
P11.12	Underload pre-alarm detection time	<p>Setting range of P11.11: 0~P11.09</p> <p>Setting range of P11.12: 0.1~3600.0s</p>	1.0s	<input type="radio"/>
P11.13	Output terminal action during fault	<p>Select the action of fault output terminals on undervoltage and fault reset.</p> <p>0x00~0x11</p> <p>LED ones:</p> <p>0: Action under fault undervoltage</p> <p>1: No action under fault undervoltage</p> <p>LED tens:</p> <p>0: Action during the automatic reset</p> <p>1: No action during the automatic reset</p>	0x00	<input type="radio"/>
P11.14	Speed deviation detection	<p>0.0~50.0%</p> <p>Set the speed deviation detection time.</p>	10.0%	<input type="radio"/>
P11.15	Speed deviation	<p>This parameter is used to set the speed deviation detection time.</p>	0.5s	<input type="radio"/>

Function code	Name	Detailed instruction of parameters		Default value	Modify
	detection time	<p>Actual detecting value</p> <p>Setting detecting value</p> <p>t_1 t_2</p> <p>In running Fault output DEu</p> <p>$T_1 < t_2$, so the inverter continues to work $t_2 = P11.15$ Setting range of P11.15: 0.0~10.0s</p>			
P11.16	Automatic frequency decreasing at voltage drop	0: Invalid 1: Valid; ensure rated output torque when voltage drop		0	○
P12 Group Motor 2					
P12.00	Motor type 2	0: Asynchronous motor 1: Synchronous motor Note: Switch the current motor by the switching channel of P08.31.		0	◎
P12.01	Rated power of asynchronous motor 2	0.1~3000.0kW	Set the parameter of the controlled asynchronous motor.	Depend on model	◎
P12.02	Rated frequency of asynchronous motor 2	0.01Hz~P00.03 (Max. output frequency)	In order to ensure the control performance, set the P12.01~P12.05 according to the name plate of asynchronous motor.	50.00Hz	◎
P12.03	Rated speed of asynchronous motor 2	1~36000rpm	Goodrive300-02 series inverters provide the function of parameter autotuning. Correct parameter autotuning comes	Depend on model	◎
P12.04	Rated voltage of asynchronous	0~1200V	from the correct setting of the motor name plate. In order to ensure the control	Depend on model	◎

Function code	Name	Detailed instruction of parameters		Default value	Modify
	motor 2		performance, please configure		
P12.05	Rated current of asynchronous motor 2	0.8~6000.0A	the motor according to the standard principles, if the gap between the motor and the standard one is huge, the control performance of the inverter will decrease. Note: Resetting P12.01 can initialize P12.02~P12.05	Depend on model	☉
P12.06	Stator resistor of asynchronous motor 2	0.001~65.535Ω	After completing the motor parameter autotuning, the set value of P12.06~P12.10 will update automatically. As the basic parameters of high performance vector control, the parameters have a direct impact on control performance. Note: Users cannot modify the parameters freely.	Depend on model	○
P12.07	Rotor resistor of asynchronous motor 2	0.001~65.535Ω		Depend on model	○
P12.08	Leakage inductance of asynchronous motor 2	0.1~6553.5mH		Depend on model	○
P12.09	Mutual inductance of asynchronous motor 2	0.1~6553.5mH		Depend on model	○
P12.10	Non-load current of asynchronous motor 2	0.1~6553.5A		Depend on model	○
P12.11	Magnetic saturation coefficient 1 for the iron	0.0~100.0%		80.0%	○

Function code	Name	Detailed instruction of parameters		Default value	Modify
	core of AM2				
P12.12	Magnetic saturation coefficient 2 for the iron core of AM2	0.0~100.0%		68.0%	○
P12.13	Magnetic saturation coefficient 3 for the iron core of AM2	0.0~100.0%		57.0%	○
P12.14	Magnetic saturation coefficient 4 for the iron core of AM2	0.0~100.0%		40.0%	○
P12.15	Rated power of synchronous motor 2	0.1~3000.0kW	Set the parameter of the controlled asynchronous motor. In order to ensure the controlling performance, set the P12.15~P12.19 according to the name plate of the asynchronous motor. Goodrive300-02 series inverters provide the function of parameter autotuning. Correct parameter autotuning comes from the correct setting of the motor name plate.	Depend on model	◎
P12.16	Rated frequency of synchronous motor 2	0.01Hz~P00.03 (Max. output frequency)		50.00Hz	◎
P12.17	Number of poles pairs for synchronous motor 2	1~50		2	◎
P12.18	Rated voltage of synchronous motor 2	0~1200V		Depend on model	◎

Function code	Name	Detailed instruction of parameters		Default value	Modify
P12.19	Rated current of synchronous motor 2	0.8~6000.0A	In order to ensure the controlling performance, please configure the motor according to the standard principles, if the gap between the motor and the standard one is huge, the features of the inverter will decrease. Note: Reset the rated power of the motor(P12.15), initialize the motor parameter of P12.16~ P12.19.	Depend on model	◎
P12.20	Stator resistor of synchronous motor 2	0.001~65.535Ω	After finish the motor parameter autotuning, the set value of P12.20~P12.22 will renew automatically.	Depend on model	○
P12.21	Direct axis inductance of synchronous motor 2	0.01~655.35mH	These parameters are basic parameters controlled by vectors which directly impact the features.	Depend on model	○
P12.22	Quadrature axis inductance of synchronous motor 2	0.01~655.35mH	When P00.15=1, the set value of P12.23 can be updated through autotuning automatically, and there is no need to change the value of P12.23; when P00.15=2, the set value of P12.23 cannot be updated through autotuning, please account and	Depend on model	○
P12.23	Back EMF constant of synchronous motor 2	When P00.15=2, the set value of P12.23 cannot be updated by autotuning, please count according to the following method. The counter-		300	○

Function code	Name	Detailed instruction of parameters		Default value	Modify
		electromotive force constant can be counted according to the parameters on the name plate of the motor. There are three ways to count: 1. If the name plate designates the counter-electromotive force constant K_e , then: $E=(K_e \cdot n_N \cdot 2\pi)/60$ 2. If the name plate designates the counter-electromotive force constant E' (V/1000r/min), then: $E=E' \cdot n_N / 1000$ 3. If the name plate does not designate the above parameters, then: $E=P/\sqrt{3} \cdot I$ In the above formulas: n_N is the rated rotation speed, P is the rated power and I is the rated current. Setting range: 0~10000	update the value of P12.23. Note: Users cannot modify the parameters freely.		
P12.24	Initial pole position of synchronous motor 2 (reserved)	0~FFFFH (reserved)		0x0000	●
P12.25	Identification current of synchronous motor 2	0%~50%(the rated current of the motor)(reserved)		10%	●

Function code	Name	Detailed instruction of parameters	Default value	Modify
	(reserved)			
P12.26	Motor 2 overload protection	0: No protection 1: Common motor (with low speed compensation) 2: Variable frequency motor (without low speed compensation)	2	<input checked="" type="radio"/>
P12.27	Motor 2 overload protection coefficient	<p>Times of motor overload $M = I_{out} / (I_n * K)$</p> <p>I_n is the rated current of the motor, I_{out} is the output current of the inverter and K is the motor protection coefficient.</p> <p>So, the bigger the value of K is, the smaller the value of M is. When $M = 116\%$, the fault will be reported after 1 hour, when $M = 200\%$, the fault will be reported after 1 minute, when $M \geq 400\%$, the fault will be reported instantly.</p> <p>Setting range: 20.0%~120.0%</p>	100.0%	<input type="radio"/>
P12.28	Correction coefficient of motor 2 power	Correct the power displaying of motor 2. Only impact the displaying value other than the control performance of the inverter. Setting range: 0.00~3.00	1.00	<input type="radio"/>
P12.29	Parameter display of motor 2	0: Display according to the motor type: only the parameters relative to the current motor type are displayed for the convenient for the customers in this mode. 1: All parameters are displayed: all parameters are displayed in this mode.	0	<input type="radio"/>
P13 Group Synchronous motor control				

Function code	Name	Detailed instruction of parameters	Default value	Modify
P13.00	Reduction coefficient of source current	0.0~100.0%	80.0%	<input type="radio"/>
P13.01	Original pole test mode	0: No test 1: High-frequency superposition (reserved) 2: Pulse superposition	0	<input checked="" type="radio"/>
P13.02	Source current 1	Source current is the positioning current of the magnetic pole position. Source current 1 is valid under the frequency point of current shifting. Increasing the value can raise the starting torque. Setting range: 0.0%~100.0% (rated current of the motor)	20.0%	<input type="radio"/>
P13.03	Source current 2	Source current is directional current of the magnetic pole position. Source current 2 is valid under the frequency point of current shifting. There is no need to modify the value generally. Setting range: 0.0%~100.0% (rated current of the motor)	10.0%	<input type="radio"/>
P13.04	Shift frequency of source current	Valid frequency shifting point between source current 1 and current 2. Setting range: 0.00Hz~P00.03	10.00Hz	<input type="radio"/>
P13.05	Superposing frequency (reserved)	200~1000Hz	500Hz	<input checked="" type="radio"/>
P13.06	Pulse superposing voltage	0.0~300.0% (rated voltage of the motor)	40.0%	<input checked="" type="radio"/>
P13.07	Reserved	0~65535	0	<input type="radio"/>
P13.08	Control parameter 1	0~65535	0	<input type="radio"/>
P13.09	Control parameter 2	0~655.35	2.00	<input type="radio"/>
P13.10	Reserved	0~65535	0	<input type="radio"/>

Function code	Name	Detailed instruction of parameters	Default value	Modify
P13.11	Maladjustment detection time	Adjust the response of anti-maladjustment. Bigger load inertia may increase the value, but the response will be slower. Setting range: 0.0~10.0s	0.5s	<input type="radio"/>
P13.12	High frequency compensation coefficient	When the motor speed is faster than the rated speed, the parameter is valid, if vibration occurs to the motor, please adjust the parameter. Setting range: 0~100.0%	0.0%	<input type="radio"/>
P13.13	Braking current of short-circuit	When P01.00=0 during the starting of the inverter, set P13.14 to a non-zero value to enter the short circuit braking.	0.0%	<input type="radio"/>
P13.14	Braking retention time before starting	When the running frequency is lower than P01.09 during the stopping of the inverter, set 13.15 to a non-zero value to enter into stopping short circuited braking and then carry out the DC braking at the time set by P01.12 (refer to the instruction of P01.09~P01.12) .	0.00s	<input type="radio"/>
P13.15	Braking retention time when stopping	Setting range of P13.13: 0.0~150.0% (the inverter) Setting range of P13.14: 0.00~50.00s Setting range of P13.15: 0.00~50.00s	0.00s	<input type="radio"/>
P14 Group Serial communication				
P14.00	Local communication address	The setting range: 1~247 When the master is writing the frame, the communication address of the slave is set to 0; the address is the communication address. All slaves on the MODBUS fieldbus can receive the frame, but the slave does not answer. The communication of the drive is unique in the communication net. This is the fundamental for the point to point communication between the upper computer and the drive. Note: The address of the slave cannot be set to 0.	1	<input type="radio"/>
P14.01	Communication speed	Set the digital transmission speed between the upper	4	<input type="radio"/>

Function code	Name	Detailed instruction of parameters	Default value	Modify
	on baud ratio	<p>computer and the inverter.</p> <p>0: 1200BPS 1: 2400BPS 2: 4800BPS 3: 9600BPS 4: 19200BPS 5: 38400BPS 6: 57600BPS 7: 115200BPS</p> <p>Note: The baud rate between the upper computer and the inverter must be the same. Otherwise, the communication is not applied. The bigger the baud rate, the quicker the communication speed.</p>		
P14.02	Digital bit checkout	<p>The data format between the upper computer and the inverter must be the same. Otherwise, the communication is not applied.</p> <p>0: No check (N,8,1) for RTU 1: Odd check (E,8,1) for RTU 2: Even check (O,8,1) for RTU 3: No check (N,8,2) for RTU 4: Odd check (E,8,2) for RTU 5: Even check(O,8,2) for RTU</p>	1	○
P14.03	Answer delay	<p>0~200ms</p> <p>The interval time when the drive receives the data and sends it to the upper computer. If the answer delay is shorter than the system processing time, then the answer delay time is the system processing time; if the answer delay is longer than the system processing time, then after the system deals with the data, wait until achieving the answer delay time to send the data to the upper computer.</p>	5	○
P14.04	Fault time of communicatio	<p>0.0 (invalid), 0.1~60.0s</p> <p>When the function code is set as 0.0, the</p>	0.0s	○

Function code	Name	Detailed instruction of parameters	Default value	Modify
	n overtime	communication overtime parameter is invalid. When the function code is set as non-zero, if the interval time between two communications exceeds the communication overtime, the system will report "485 communication faults" (CE). Generally, set it as invalid; set the parameter in the continuous communication to monitor the communication state.		
P14.05	Transmission fault processing	0: Alarm and stop freely 1: No alarm and continue to run 2: No alarm and stop according to the stop mode (only under the communication control) 3: No alarm and stop according to the stop mode (under all control modes)	0	○
P14.06	Communication processing	0x00~0x11 LED ones: Write action 0: Write with response: the inverter will respond to all reading and writing commands of upper computer. 1: Write without response: the inverter only responds to the reading command other than the writing command of upper computer. The communication efficiency can be increased by this method. LED tens: Communication encryption processing 0: Communication encrypting is invalid 1: Communication encrypting is valid	0x00	○
P15 Group PROFIBUS function				
P15.00	Module type	0: PROFIBUS 1: CANopen Select communication protocol	0	◎
P15.01	Module address	0~127 This function code is used to designate the address of the inverter. Note: 0 is the broadcast address, when set it as	2	◎

Function code	Name	Detailed instruction of parameters	Default value	Modify
		broadcast address, only receive the radio command of the upper computer other than answering the upper computer.		
P15.02	PZD2 receiving	0: Invalid	0	<input type="radio"/>
P15.03	PZD3 receiving	1: Setting frequency (0~Fmax(unit: 0.01Hz))	0	<input type="radio"/>
P15.04	PZD4 receiving	2: PID reference, range(0~1000, 1000 corresponds to 100.0%)	0	<input type="radio"/>
P15.05	PZD5 receiving	3: PID feedback, range(0~1000, 1000 corresponds to 100.0%)	0	<input type="radio"/>
P15.06	PZD6 receiving	4: Torque setting (-3000~3000, 1000 corresponds to 100.0% the rated current of the motor)	0	<input type="radio"/>
P15.07	PZD7 receiving	5: Upper frequency of forward rotation (0~Fmax (unit: 0.01Hz))	0	<input type="radio"/>
P15.08	PZD8 receiving	6: Upper frequency of reverse rotation (0~Fmax (unit: 0.01Hz))	0	<input type="radio"/>
P15.09	PZD9 receiving	7: Electromotion torque upper limit (0~3000,1000 corresponds to 100.0%of the rated current of the motor)	0	<input type="radio"/>
P15.10	PZD10 receiving	8: Braking torque upper limit (0~2000, 1000 corresponds to 100.0% of the rated current of the motor)	0	<input type="radio"/>
P15.11	PZD11 receiving	9: Virtual input terminals command Range: 0x00~0x1FF	0	<input type="radio"/>
P15.12	PZD12 receiving	10: Virtual output terminals command Range: 0x00~0x0F 11: Voltage setting value (special for V/F separation)(0~1000, 1000 corresponds to 100.0% the rated voltage of the motor) 12: AO output set value 1 (-1000~1000,1000 corresponds to 100.0%) 13: AO output set value 2 (-1000~1000,1000 corresponds to 100.0%) 14~20: Reserved	0	<input type="radio"/>
P15.13	PZD2 sending	0: Invalid 1: Running frequency (*100, Hz)	0	<input type="radio"/>

Function code	Name	Detailed instruction of parameters	Default value	Modify
P15.14	PZD3 sending	2: Setting frequency (*100, Hz)	0	<input type="radio"/>
P15.15	PZD4 sending	3: Bus voltage (*10, V) 4: Output voltage (*1, V) 5: Output current (*10, A)	0	<input type="radio"/>
P15.16	PZD5 sending	6: Output torque actual value (*10, %) 7: Output power actual value (*10, %)	0	<input type="radio"/>
P15.17	PZD6 sending	8: Running rotating speed(*1, RPM) 9: Running linear speed (*1, m/s)	0	<input type="radio"/>
P15.18	PZD7 sending	10: Ramp reference frequency 11: Fault code	0	<input type="radio"/>
P15.19	PZD8 sending	12: AI1 value (*100, V) 13: AI2 value (*100, V)	0	<input type="radio"/>
P15.20	PZD9 sending	14: AI3 value (*100, V) 15: PULSE frequency value (*100, kHz)	0	<input type="radio"/>
P15.21	PZD10 sending	16: Terminals input state 17: Terminals output state	0	<input type="radio"/>
P15.22	PZD11 sending	18: PID reference (*100, %) 19: PID feedback (*100, %)	0	<input type="radio"/>
P15.23	PZD12 sending	20: Motor rated torque 21: Control word	0	<input type="radio"/>
P15.24	Temporarily variable 1 for PZD sending	0~65535	0	<input type="radio"/>
P15.25	Fault time of DP communication overtime	0.0 (invalid), 0.1~60.0s When this function code is set as 0.0, this function is invalid. When the function code is set as nonzero value, if the interval time between two adjacent communication exceeds the communication overtime, the system will report "PROFIBUS/CANopen communication fault" (E-DP).	0.0s	<input type="radio"/>
P15.26	Fault time of CANopen communication overtime	0.0 (invalid), 0.1~60.0s When this function code is set as 0.0, this function is invalid. When the function code is set as nonzero value, if the	0.0s	

Function code	Name	Detailed instruction of parameters	Default value	Modify
		interval time between two adjacent communication exceeds the communication overtime, the system will report "CANopen communication fault" (E-CAN)		
P15.27	CANopen baud rate	0: 1000k 1: 800k 2: 500k 3: 250k 4: 125k 5: 100k 6: 50k 7: 20k	0	●
P16 Group Ethernet function				
P16.00	Speed setting of the Ethernet communication	0: Self-adapting 1: 100M full duplex 2: 100M semiduplex 3: 10M full duplex 4: 10M semiduplex The function code is used to set the Ethernet communication speed.	0	◎
P16.01	IP address 1	0~255	192	◎
P16.02	IP address 2	Set the IP address of Ethernet communication	168	◎
P16.03	IP address 3	The format of IP address: P16.09.P16.10.P16.11.P16.12	0	◎
P16.04	IP address 4	For example: IP address is 192.168.0.1.	1	◎
P16.05	Subnet mask 1		255	◎
P16.06	Subnet mask 2	0~255 Set the subnet mask of Ethernet communication.	255	◎
P16.07	Subnet mask 3	The format of IP subnet mask: P16.13.P16.14.P16.15.P16.16.	255	◎
P16.08	Subnet mask 4	For example: The mask is 255.255.255.0.	0	◎
P16.09	Gateway 1	0~255	192	◎

Function code	Name	Detailed instruction of parameters	Default value	Modify
P16.10	Gateway 2	Set the gateway of Ethernet communication	168	⊙
P16.11	Gateway 3		1	⊙
P16.12	Gateway 4		1	⊙
P17 Group Monitoring function				
P17.00	Setting frequency	Display current set frequency of the inverter Range: 0.00Hz~P00.03	0.00Hz	●
P17.01	Output frequency	Display current output frequency of the inverter Range: 0.00Hz~P00.03	0.00Hz	●
P17.02	Ramp reference frequency	Display current ramp reference frequency of the inverter Range: 0.00Hz~P00.03	0.00Hz	●
P17.03	Output voltage	Display current output voltage of the inverter Range: 0~1200V	0V	●
P17.04	Output current	Display current output current of the inverter Range: 0.0~3000.0A	0.0A	●
P17.05	Motor speed	Display the rotation speed of the motor. Range: 0~65535RPM	0RPM	●
P17.06	Torque current	Display current torque current of the inverter Range: -3000.0~3000.0A	0.0A	●
P17.07	Exciting current	Display current exciting current of the inverter Range: -3000.0~3000.0A	0.0A	●
P17.08	Motor power	Display current power of the motor. 100.0% corresponds to motor rated power, positive in electromotion state and negative in power generation. Setting range: -300.0%~300.0% (relative to the rated power of the motor)	0.0%	●
P17.09	Output torque	Display the current output torque of the inverter. 100.0% corresponds to motor rated torque, positive in electromotion state and negative in power generation. Range: -250.0~250.0%	0.0%	●
P17.10	Evaluated motor	Evaluate the motor rotor frequency on open loop vector.	0.00Hz	●

Function code	Name	Detailed instruction of parameters	Default value	Modify																				
	frequency	Range: 0.00~P00.03																						
P17.11	DC bus voltage	Display current DC bus voltage of the inverter. Range: 0.0~2000.0V	0.0V	●																				
P17.12	Digital input terminals state	Display current switch input terminals state of the inverter. <table border="1" style="margin-left: 20px;"> <tr> <td></td> <td>BIT8</td> <td>BIT7</td> <td>BIT6</td> <td>BIT5</td> </tr> <tr> <td></td> <td>HDI</td> <td>S8</td> <td>S7</td> <td>S6</td> </tr> <tr> <td>BIT4</td> <td>BIT3</td> <td>BIT2</td> <td>BIT1</td> <td>BIT0</td> </tr> <tr> <td>S5</td> <td>S4</td> <td>S3</td> <td>S2</td> <td>S1</td> </tr> </table> Range: 0000~01FF		BIT8	BIT7	BIT6	BIT5		HDI	S8	S7	S6	BIT4	BIT3	BIT2	BIT1	BIT0	S5	S4	S3	S2	S1	0	●
	BIT8	BIT7	BIT6	BIT5																				
	HDI	S8	S7	S6																				
BIT4	BIT3	BIT2	BIT1	BIT0																				
S5	S4	S3	S2	S1																				
P17.13	Digital output terminals state	Display current switch output terminals state of the inverter. <table border="1" style="margin-left: 20px;"> <tr> <td>BIT3</td> <td>BIT2</td> <td>BIT1</td> <td>BIT0</td> </tr> <tr> <td>RO2</td> <td>RO1</td> <td>HDO</td> <td>Y</td> </tr> </table> Range: 0000~000F	BIT3	BIT2	BIT1	BIT0	RO2	RO1	HDO	Y	0	●												
BIT3	BIT2	BIT1	BIT0																					
RO2	RO1	HDO	Y																					
P17.14	Digital adjustment	Display the adjustment through the keypad of the inverter. Range : 0.00Hz~P00.03	0.00Hz	●																				
P17.15	Torque reference	Display the torque reference, the percentage to the current rated torque of the motor. Setting range: -300.0%~300.0% (the rated current of the motor)	0.0%	●																				
P17.16	Linear speed	Display the current linear speed of the inverter. Range: 0~65535	0	●																				
P17.17	Length value	Display the current length of the inverter. Range: 0~65535	0	●																				
P17.18	Count value	Display the current count value of the inverter. Range: 0~65535	0	●																				
P17.19	AI1 input voltage	Display analog AI1 input signal. Range: 0.00~10.00V	0.00V	●																				
P17.20	AI2 input voltage	Display analog AI2 input signal. Range: 0.00~10.00V	0.00V	●																				
P17.21	AI3 input	Display analog AI2 input signal.	0.00V	●																				

Function code	Name	Detailed instruction of parameters	Default value	Modify
	voltage	Range: -10.00~10.00V		
P17.22	HDI input frequency	Display HDI input frequency. Range: 0.000~50.000kHz	0.000 kHz	●
P17.23	PID reference	Display PID reference value. Range: -100.0~100.0%	0.0%	●
P17.24	PID feedback	Display PID response value. Range: -100.0~100.0%	0.0%	●
P17.25	Power factor of the motor	Display the current power factor of the motor. Range: -1.00~1.00	0.00	●
P17.26	Current running time	Display the current running time of the inverter. Range: 0~65535min	0min	●
P17.27	Current step of the multi-step speed	Display the current step of the multi-step speed Range: 0~15	0	●
P17.28	ASR controller output	The percentage of the rated torque of the relative motor, display ASR controller output Range: -300.0%~300.0% (the rated current of the motor)	0.0%	●
P17.29	Magnetic pole angle of SM	Display synchronous motor Magnetic pole angle Range: 0.0~360.0	0.0	●
P17.30	Phase compensation of SM	Display synchronous motor phase compensation Range: -180.0~180.0	0.0	●
P17.31	High-frequency superimposed current of SM	Display synchronous motor high-frequency Superimposed current Range: 0.0~200.0% (the rated current of the motor)	0.0%	●
P17.32	Magnetic flux linkage	Display the magnetic flux linkage of the motor. Range: 0.0~200.0%	0.0%	●

Function code	Name	Detailed instruction of parameters	Default value	Modify
P17.33	Exciting current reference	Display the exciting current reference in the vector control mode. Range: -3000.0~3000.0A	0.0A	●
P17.34	Torque current reference	Display the torque current reference in the vector control mode. Range: -3000.0~3000.0A	0.0A	●
P17.35	AC current	Display the value of inlet current in AC side. Range: 0.0~5000.0A	0.0A	●
P17.36	Output torque	Display the output torque, positive in electromotion state and negative in power generation. Range : -3000.0Nm~3000.0Nm	0.0Nm	●
P17.37	Count value of motor overload	0~100 (100 reports OL1 fault)	0	●
P17.38	PID output	-100.00~100.00%	0.00%	●
P17.39	Wrong download of parameters	0.00~99.99	0.00	●

Basic operation instruction

7

7.1 What this chapter contains

This chapter describes the internal function modules of the inverter in details.



- ◇ Check all terminals are connected properly and tightly.
- ◇ Check that the power of the motor corresponds to that of the inverter.

7.2 First powering on

Check before powering on

Please check according to the installation list in Chapter 2.

Original powering operation

Check to ensure there is no mistake in wiring and power supply, switch on the air switch of the AC power supply on the input side of the inverter to power on the inverter. 8.8.8.8.8 will be displayed on the keypad, and the contactor closes normally. When the character on the nixie tube changes to the set frequency, the inverter has finished the initialization and it is in the stand-by state.

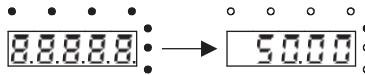

LED displays “8. 8. 8. 8. 8” and in the stand-by state, 7 LEDs are on.

Below diagram shows the first operation: (take motor 1 as the example)

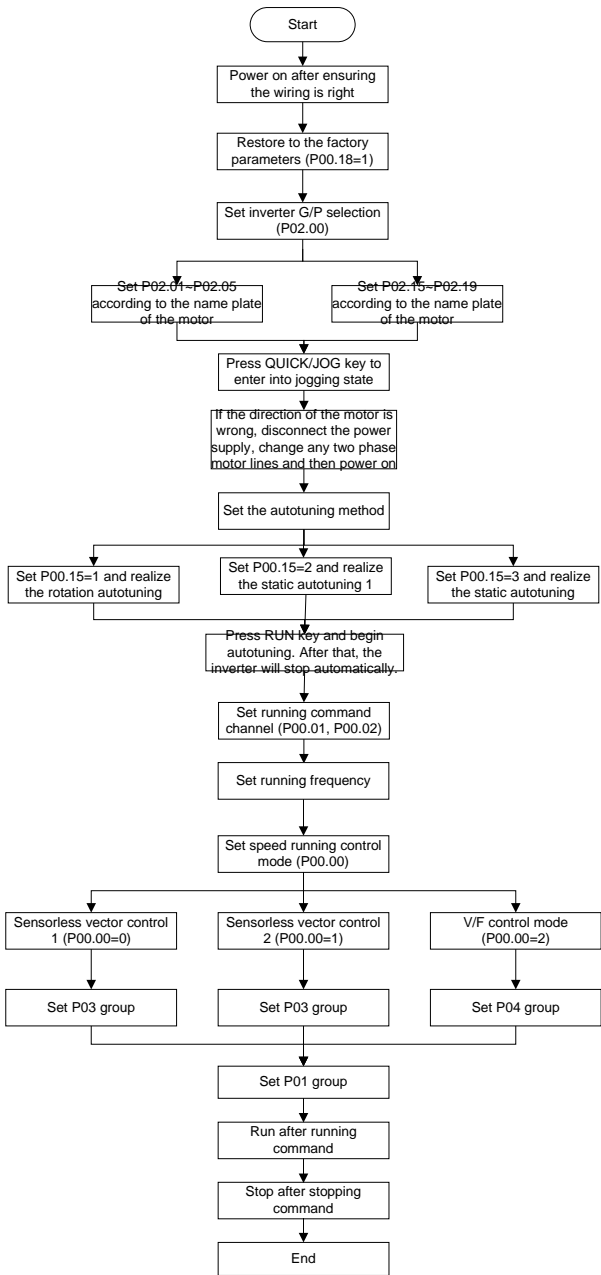

Note: If a fault occurs, please do as “Fault Tracking” to judge the reason and settle the issue.

Besides P00.01 and P00.02, terminal command setting can also be used to set the running command channel.

Current running command channel P00.01	Multi-function terminal 36 Switch to keypad	Multi-function terminal 37 Switch to terminal	Multi-function terminal 38 Switch to communication
Keypad running command channel	/	Terminal running command channel	Communication running command channel
Terminal running command channel	Keypad running command channel	/	Communication running command channel
Communication running command channel	Keypad running command channel	Terminal running command channel	/

Note: “/” means the multi-function terminal is invalid on the current reference channel.

Relative parameters table:

Function code	Name	Detailed instruction of parameters	Default value
P00.00	Speed control mode	0: Sensorless vector control mode 0 1: Sensorless vector control mode 1 2: SVPWM control mode (apply to AM, SM)	1
P00.01	Running command channel	0: Keypad running command channel (LED off) 1: Terminal running command channel (LED flickering) 2: Communication running command channel (LED on)	0
P00.02	Communication running commands	0: MODBUS communication channel 1: PROFIBUS/CANopen communication channel 2: Ethernet communication channel 3: Reserved	0
P00.15	Motor parameter autotuning	0: No operation 1: Rotation autotuning 2: Static autotuning 1 (autotune totally) 3: Static autotuning 2 (autotune partially)	0

Function code	Name	Detailed instruction of parameters	Default value
P00.18	Function restore parameter	0: No operation 1: Restore the default value 2: Cancel the fault record	0
P02.00	Motor type 1	0: Asynchronous motor 1: Synchronous motor	0
P02.01	Rated power of asynchronous motor 1	0.1~3000.0kW	Depend on model
P02.02	Rated frequency of asynchronous motor 1	0.01Hz~P00.03 (Max. output frequency)	50.00Hz
P02.03	Rated speed of asynchronous motor 1	1~36000rpm	Depend on model
P02.04	Rated voltage of asynchronous motor 1	0~1200V	Depend on model
P02.05	Rated current of asynchronous motor 1	0.8~6000.0A	Depend on model
P02.15	Rated power of synchronous motor 1	0.1~3000.0kW	Depend on model
P02.16	Rated frequency of synchronous motor 1	0.01Hz~P00.03 (Max. output frequency)	50.00Hz

Function code	Name	Detailed instruction of parameters	Default value
P02.17	Number of poles pairs for synchronous motor 1	1~50	2
P02.18	Rated voltage of synchronous motor 1	0~1200V	Depend on model
P02.19	Rated current of synchronous motor 1	0.8~6000.0A	Depend on model
P05.01~P05.09	Multi-function digital input terminals (S1~S8, HDI)	36: Shift the command to the keypad 37: Shift the command to the terminal 38: Shift the command to the communication	
P07.01	Parameter copy	The function code determines the manner of parameters copy. 0: No operation 1: Upload the local function parameter to the keypad 2: Download the keypad function parameter to local address (including the motor parameters) 3: Download the keypad function parameter to local address (excluding the motor parameter of P02 and P12 group) 4: Download the keypad function parameters to local address (only for the motor parameter of P02 and P12 group)	0
P07.02	QUICK/JOG function selection	0: No function 1: Jogging 2: Shift the display state by the shifting key 3: Shift between forward rotations and reverse rotations 4: Clear UP/DOWN settings	1

Function code	Name	Detailed instruction of parameters	Default value
		5: Coast to stop 6: Shift the reference manner of running commands 7: Quick commission mode (commission according to the non-factory parameter)	

7.3 Vector control

Because asynchronous motors have the characteristics of high stage, nonlinear, strong coupling and various variables, the actual control of the asynchronous motor is very difficult. Vector control is mainly used to settle this problem with the theme of that divide the stator current vector into exciting current (the current heft generating internal magnetic field of the motor) and torque current (the current heft generating torque) by controlling and measuring the stator current vector according to the principles of beamed magnetic field to control the range and phase of these two hefts. This method can realize the decoupling of exciting current and torque current to adjust the high performance of asynchronous motors.

Goodrive300-02 series inverters are embedded speedless sensor vector control calculation. Because the core calculation of vector control is based on exact motor parameter models, the accuracy of motor parameter will impact on the performance of vector control. It is recommended to input the motor parameters and carry out autotune before vector running.

Because the vector control calculation is very complicated, high technical theory is needed for the user during internal autotune. It is recommended to use the specific function parameters in vector control with cautions.

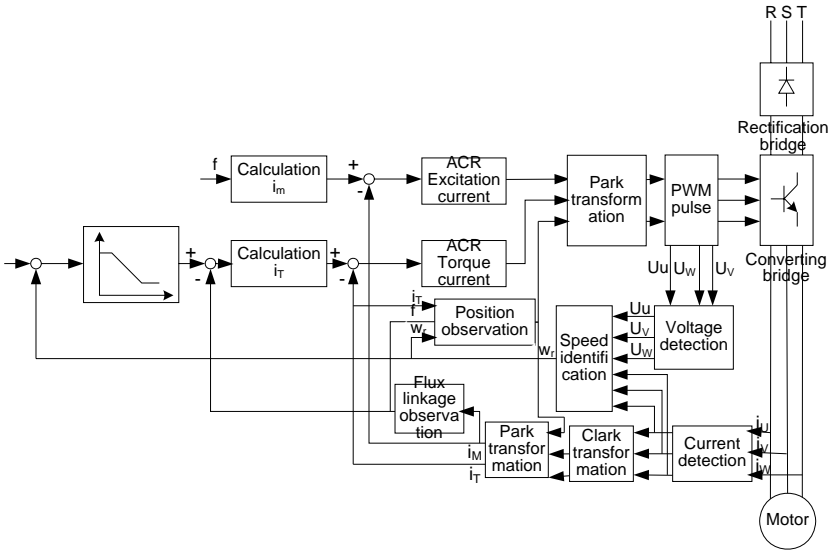

Function code	Name	Detailed instruction of parameters	Default value
P00.00	Speed control mode	0: Sensorless vector control mode 0 (apply to AM, SM) 1: Sensorless vector control mode 1 (apply to AM) 2: SVPWM control mode (apply to AM, SM)	1
P00.15	Motor parameter autotuning	0: No operation 1: Rotation autotuning 2: Static autotuning 1 (autotune totally) 3: Static autotuning 2 (autotune partially)	0
P02.00	Motor type 1	0: Asynchronous motor 1: Synchronous motor	0
P03.00	Speed loop proportional gain 1	0~200.0	20.0
P03.01	Speed loop integral time 1	0.000~10.000s	0.200s
P03.02	Low switching frequency	0.00Hz~P03.05	5.00Hz
P03.03	Speed loop proportional	0~200.0	20.0

	gain 2		
P03.04	Speed loop integral time 2	0.000~10.000s	0.200s
P03.05	High switching frequency	P03.02~P00.03 (Max. output frequency)	10.00Hz
P03.06	Speed loop output filter	0~8 (corresponding to 0~2 ⁸ /10ms)	0
P03.07	Compensation coefficient of electromotion slip	50%~200%	100%
P03.08	Compensation coefficient of braking slip	50%~200%	100%
P03.09	Current loop proportional coefficient P	0~65535	1000
P03.10	Current loop integral coefficient I	0~65535	1000
P03.11	Torque setting method	0: Torque control is invalid 1: Keypad setting torque (P03.12) 2: Analog AI1 setting torque 3: Analog AI2 setting torque 4: Analog AI3 setting torque 5: Pulse frequency HDI setting torque 6: Multi-step torque setting 7: MODBUS communication setting torque 8: PROFIBUS/CANopen communication setting torque 9: Ethernet communication setting torque 10: Reserved Note: Setting modes 2~10, 100% corresponds to three times of the rated current of the motor.	0
P03.12	Keypad setting torque	-300.0%~300.0% (rated current of the motor)	50.0%

P03.13	Torque reference filter time	0.000~10.000s	0.010s
P03.14	Upper frequency of forward rotation in torque control	<p>0: Keypad (P03.16 sets P03.14, P03.17 sets P03.15)</p> <p>1: AI1</p> <p>2: AI2</p> <p>3: AI3</p> <p>4: Pulse frequency HDI setting upper-limit frequency</p> <p>5: Multi-step setting upper-limit frequency</p> <p>6: MODBUS communication setting upper-limit frequency</p> <p>7: PROFIBUS/CANopen communication setting upper-limit frequency</p> <p>8: Ethernet communication setting upper-limit frequency</p> <p>9: Reserved</p> <p>Note: Setting modes 1~9, 100% corresponds to the maximum frequency.</p>	0
P03.15	Upper frequency of reverse rotation in torque control	<p>0: Keypad (set by P03.17)</p> <p>1~9: The same as P03.14</p>	0
P03.16	Keypad setting for upper frequency of forward rotation	Setting range: 0.00Hz~P00.03 (Max. output frequency)	50.00Hz
P03.17	Keypad setting for upper frequency of reverse rotation		50.00Hz
P03.18	Upper	0: Keypad setting upper-limit frequency (set by P03.20)	0

	electromotion torque source	1: AI1 2: AI2 3: AI3 4: HDI 5: MODBUS communication 6: PROFIBUS/CANopen communication 7: Ethernet communication 8: Reserved Note: Setting modes 1~8, 100% corresponds to three times of the motor current.	
P03.19	Upper braking torque source	0: Keypad setting upper-limit frequency (set by P03.21) 1~8: The same as P03.18	0
P03.20	Keypad setting of electromotion torque	0.0~300.0% (motor rated current)	180.0%
P03.21	Keypad setting of braking torque		180.0%
P03.22	Weakening coefficient in constant power zone	0.1~2.0	0.3
P03.23	Lowest weakening point in constant power zone	10%~100%	20%
P03.24	Max. voltage limit	0.0~120.0%	100.0%
P03.25	Pre-exciting time	0.000~10.000s	0.300s

P17.32	Magnetic flux linkage	0.0%~200.0%	0.0%
--------	-----------------------	-------------	------

7.4 SVPWM control

Goodrive300-02 series inverters provide internal SVPWM control which can be used in the cases where it does not need high control accuracy. It is also recommended to use SVPWM control when one inverter drives multiple motors.

Goodrive300-02 series inverters provide multiple V/F curve modes. The user can select the corresponding V/F curve to the site needs. Or they can set the corresponding V/F curve to their own needs.

Recommendations:

For the load of constant torque, such as the conveyor belt which runs linearly, it is properly to select linear V/F curve because it needs constant torque.

For the load of decreasing torque, such as fans and water pumps, it is properly to select corresponding 1.3th, 1.7th or 2th power of V/F curve because the actual torque is 2-squared or 3-squared of the rotating speed.

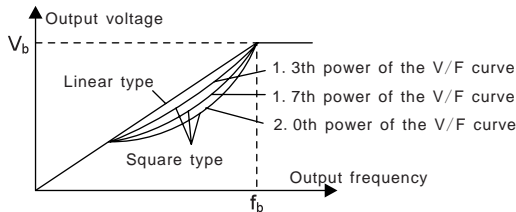

Goodrive300-02 series inverters provide multi-dots V/F curve, the user can change the output V/F curve by setting the voltage and frequency of three middle dots. The whole curve consists of 5 dots. The starting dot is (0Hz, 0V), and the ending dot is (the basic frequency of the motor, the rated voltage of the motor). During the setting processing: $0 \leq f_1 \leq f_2 \leq f_3 \leq$ the basic frequency of the motor; $0 \leq V_1 \leq V_2 \leq V_3 \leq$ the rated voltage of the motor.

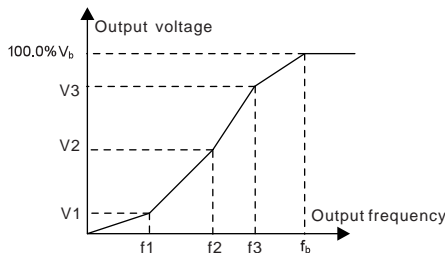

Goodrive300-02 series inverters provide special function code for SVPWM control mode which can improve the performance of SVPWM control by means of setting.

1. Torque boost

Torque boost function can compensate the performance of low speed torque during SVPWM control. The inverter will adjust the torque boost according to the actual load.

Note:

The torque boost takes effect only when the frequency is under the frequency of torque boost.

If the torque boost is too big, low frequency vibration or overcurrent fault may occur. Please lower the torque boost.

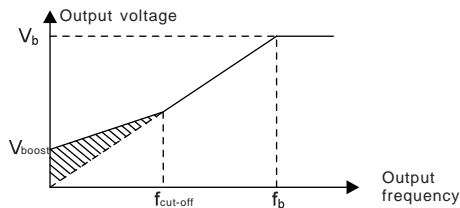

2. Energy-saving running

In the actual operation, the inverter can search by itself to achieve a better effect point. The inverter can work with high effect to save energy.

Note:

This function is usually used in the cases where the load is light or empty.

If the load transients frequently, this function is not appropriate to be selected.

3. V/F slips compensation gain

SVPWM control belongs to the open loop mode. If the load of the motor transients suddenly, the fluctuation of the rotation speed may occur. In the cases where the high accuracy speed is needed, slip compensation gain (internal output adjustment) can be set to compensate the speed change caused by load fluctuation.

Setting range of slip compensation gain: 0~200%, of which 100% corresponds to the rated slip frequency.

Note: Rated slip frequency=(rated synchronous rotation speed of the motor-rated rotation speed of the motor)*number of pole pairs/60.

4. Vibration control

Motor vibration occurs frequently when applying SVPWM control mode in the cases where high power is needed. In order to settle this problem, Goodrive300-02 series inverters add two function codes which are set to control the vibration factors. The user can set the corresponding function

code according to the vibration frequency.

Note: Bigger the set value, more effective is the control. If the set value is too big, overcurrent may occur to the motor.

5. User-defined V/F curve (V/F separation) function

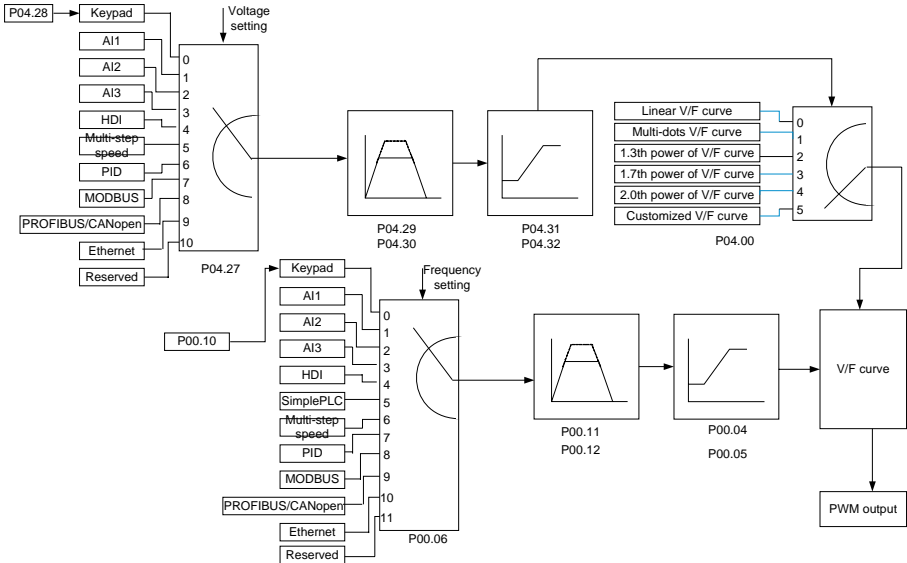

When the user selects the user-defined V/F curve function in Goodrive300-02 series inverters, they can set the reference channel of voltage and frequency and the corresponding ACC/DEC time, or the two can combine to form a real-time curve.

Note: The application of V/F curve separation can be used in many cases with various kinds of power supply of the inverter. But the users should set and adjust the parameters with caution. Incorrect parameters may cause damage to the inverter.

Function code	Name	Detailed instruction of parameters	Default value
P00.00	Speed control mode	0: Sensorless vector control mode 0 (apply to AM, SM) 1: Sensorless vector control mode 1 (apply to AM) 2: SVPWM control mode (apply to AM, SM)	1
P00.03	Max. output frequency	P00.04~400.00Hz	50.00Hz
P00.04	Upper limit of running frequency	P00.05~P00.03	50.00Hz

P00.05	Lower limit of running frequency	0.00Hz~P00.04	0.00Hz
P00.11	ACC time 1	0.0~3600.0s	Depend on model
P00.12	DEC time 1	0.0~3600.0s	Depend on model
P02.00	Motor type 1	0: Asynchronous motor 1: Synchronous motor	0
P02.02	Rated frequency of asynchronous motor 1	0.01Hz~P00.03 (Max. output frequency)	50.00Hz
P02.04	Rated voltage of asynchronous motor 1	0~1200V	Depend on model
P04.00	Motor 1 V/F curve setting	0: Straight line V/F curve 1: Multi-dots V/F curve 2: 1.3th power low torque V/F curve 3: 1.7th power low torque V/F curve 4: 2.0th power low torque V/F curve 5: Customized V/F (V/F separation)	0
P04.01	Torque boost of motor 1	0.0%: (automatic) 0.1%~10.0%	0.0%
P04.02	Torque boost close of motor 1	0.0%~50.0% (rated frequency of motor 1)	20.0%
P04.03	V/F frequency 1 of motor 1	0.00Hz~P04.05	0.00Hz
P04.04	V/F voltage 1 of motor 1	0.0%~110.0%	0.0%
P04.05	V/F frequency 2 of	P04.03~P04.07	0.00Hz

	motor 1		
P04.06	V/F voltage 2 of motor 1	0.0%~110.0%	0.0%
P04.07	V/F frequency 3 of motor 1	P04.05~P02.02 or P04.05~P02.16	0.00Hz
P04.08	V/F voltage 3 of motor 1	0.0%~110.0%	0.0%
P04.09	V/F slip compensation gain of motor 1	0.0~200.0%	100.0%
P04.10	Vibration control factor at low frequency of motor 1	0~100	10
P04.11	Vibration control factor at high frequency of motor 1	0~100	10
P04.12	Vibration control threshold of motor 1	0.00Hz~P00.03 (Max. output frequency)	30.00Hz
P04.13	Motor 2 V/F curve setting	0: Straight line V/F curve 1: Multi-dots V/F curve 2: 1.3 th power low torque V/F curve 3: 1.7 th power low torque V/F curve 4: 2.0 th power low torque V/F curve 5: Customized V/F (V/F separation)	0
P04.14	Torque boost of motor 2	0.0%: (automatic) 0.1%~10.0%	0.0%

P04.15	Torque boost close of motor 2	0.0%~50.0% (rated frequency of motor 1)	20.0%
P04.16	V/F frequency 1 of motor 2	0.00Hz~P04.18	0.00Hz
P04.17	V/F voltage 1 of motor 2	0.0%~110.0%	0.0%
P04.18	V/F frequency 2 of motor 2	P04.16~ P04.20	0.00Hz
P04.19	V/F voltage 2 of motor 2	0.0%~110.0%	0.0%
P04.20	V/F frequency 3 of motor 2	P04.18~P02.02 or P04.18~P02.16	0.00Hz
P04.21	V/F voltage 3 of motor 2	0.0%~110.0%	0.0%
P04.22	V/F slip compensation gain of motor 2	0.0~200.0%	100.0%
P04.23	Vibration control factor at low frequency of motor 2	0~100	10
P04.24	Vibration control factor at high frequency of motor 2	0~100	10

P04.25	Vibration control threshold of motor 2	0.00Hz~P00.03 (Max. output frequency)	30.00Hz
P04.26	Energy-saving operation	0: No operation 1: Automatic energy-saving operation	0
P04.27	Voltage setting	0: Keypad: the output voltage is determined by P04.28. 1: AI1 2: AI2 3: AI3 4: HDI1 5: Multi-step speed 6: PID 7: MODBUS communication 8: PROFIBUS/CANopen communication 9: Ethernet communication 10: Reserved	0
P04.28	Keypad setting voltage	0.0%~100.0% (the rated voltage of the motor)	100.0%
P04.29	Voltage increasing time	0.0~3600.0s	5.0s
P04.30	Voltage decreasing time	0.0~3600.0s	5.0s
P04.31	Maximum output voltage	P04.32~100.0% (the rated voltage of the motor)	100.0%
P04.32	Minimum output voltage	0.0%~P04.31	0.0%

7.5 Torque control

Goodrive300-02 series inverters support two kinds of control mode: torque control and rotation speed control. The core of rotation speed is that the whole control focuses on the stable speed and ensures the setting speed is the same as the actual running speed. The Max. load should be in the range of

the torque limit. The core of torque control is that the whole control focuses on the stable torque and ensures the setting torque is the same as the actual output torque. At the same time, the output frequency is among the upper limit or the lower limit.

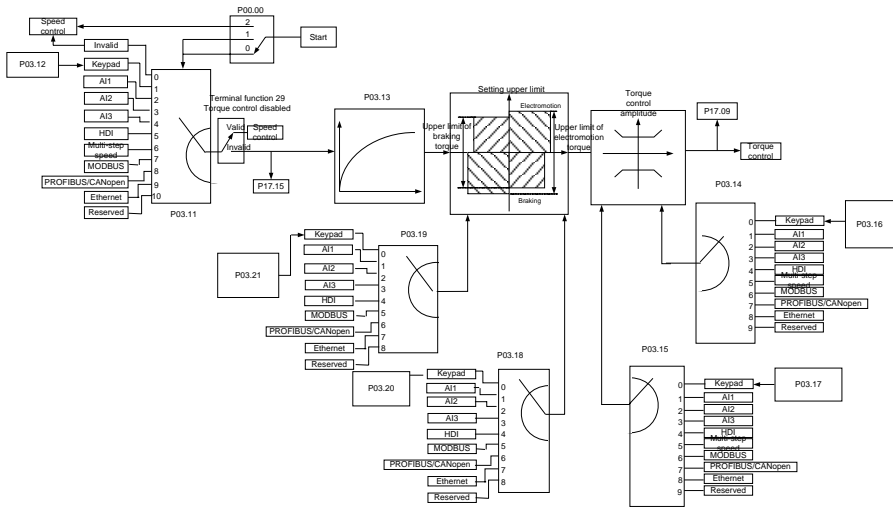



Function code	Name	Detailed instruction of parameters	Default value
P00.00	Speed control mode	0: Sensorless vector control mode 0 (apply to AM, SM) 1: Sensorless vector control mode 1 (apply to AM) 2: SVPWM control mode (apply to AM, SM)	1
P03.11	Torque setting method	0: Torque control is invalid 1: Keypad setting torque (P03.12) 2: Analog AI1 setting torque (100% corresponds to three times of the rated current of the motor) 3: Analog AI2 setting torque (the same as above) 4: Analog AI3 setting torque (the same as above) 5: Pulse frequency HDI setting torque (the same as above) 6: Multi-step torque setting (the same as above) 7: MODBUS communication setting torque (the same as above) 8: PROFIBUS/CANopen communication setting torque (the same as above) 9: Ethernet communication setting torque (the same as	0

		above) 10: Reserved	
P03.12	Keypad setting torque	-300.0%~300.0% (rated current of the motor)	50.0%
P03.13	Torque reference filter time	0.000~10.000s	0.010s
P03.14	Upper frequency of forward rotation in torque control	0: Keypad (P03.16) 1: AI1 (100% corresponds to the Max. frequency) 2: AI2 (the same as above) 3: AI3 (the same as above) 4: Pulse frequency HDI setting upper-limit frequency (the same as above) 5: Multi-step setting upper-limit frequency (the same as above) 6: MODBUS communication setting upper-limit frequency (the same as above) 7: PROFIBUS/CANopen communication setting upper-limit frequency (the same as above) 8: Ethernet communication setting upper-limit frequency (the same as above) 9: Reserved	0
P03.15	Upper frequency of reverse rotation in torque control	0: Keypad (P03.17) 1: AI1 (100% corresponds to the Max. frequency) 2: AI2 (the same as above) 3: AI3 (the same as above) 4: Pulse frequency HDI setting upper-limit frequency (the same as above) 5: Multi-step setting upper-limit frequency (the same as above) 6: MODBUS communication setting upper-limit frequency (the same as above)	0

		<p>7: PROFIBUS/CANopen communication setting upper-limit frequency (the same as above)</p> <p>8: Ethernet communication setting upper-limit frequency (the same as above)</p> <p>9: Reserved</p>	
P03.16	Keypad setting for upper frequency of forward rotation	0.00Hz~P00.03 (Max. output frequency)	50.00Hz
P03.17	Keypad setting for upper frequency of reverse rotation	0.00 Hz~P00.03 (Max. output frequency)	50.00Hz
P03.18	Upper electromotion torque source	<p>0: Keypad setting upper-limit frequency (P03.20)</p> <p>1: AI1 (100% corresponds to three times of the rated current of the motor)</p> <p>2: AI2 (the same as above)</p> <p>3: AI3 (the same as above)</p> <p>4: HDI (the same as above)</p> <p>5: MODBUS communication (the same as above)</p> <p>6: PROFIBUS/CANopen communication (the same as above)</p> <p>7: Ethernet communication (the same as above)</p> <p>8: Reserved</p>	0
P03.19	Upper braking torque source	<p>0: Keypad setting upper-limit frequency (P03.21)</p> <p>1: AI1 (100% corresponds to three times of the rated current of the motor)</p> <p>2: AI2 (the same as above)</p>	0

		<p>3: AI3 (the same as above)</p> <p>4: HDI (the same as above)</p> <p>5: MODBUS communication (the same as above)</p> <p>6: PROFIBUS/CANopen communication (the same as above)</p> <p>7: Ethernet communication (the same as above)</p> <p>8: Reserved</p>	
P03.20	Keypad setting of electromotion torque	0.0~300.0% (motor rated current)	180.0%
P03.21	Keypad setting of braking torque	0.0~300.0% (motor rated current)	180.0%
P17.09	Output torque	-250.0~250.0%	0.0%
P17.15	Torque reference	-300.0%~300.0% (the rated current of the motor)	0.0%

7.6 Parameters of the motor

	<p>◇Physical accident may occur if the motor starts up suddenly during autotune. Please check the safety of surrounding environment of the motor and the load before autotune.</p> <p>◇The power is still applied even when the motor stops running during static autotune. Please do not touch the motor until the autotune is completed, otherwise there would be electric shock.</p>
	<p>◇Do not carry out the rotation autotune if the motor is coupled with the load. Otherwise, misaction or damage may occur to the inverter or the mechanical devices. During rotation autotune on the motor which is coupled with load, the motor parameter may not be counted correctly and misaction may occur. If necessary, de-couple the motor from the load during autotune.</p>

Goodrive300-02 series inverters can drive asynchronous and synchronous motors and support two sets of motor parameters which can shift between two motors through multi-function digital input terminal or communication.

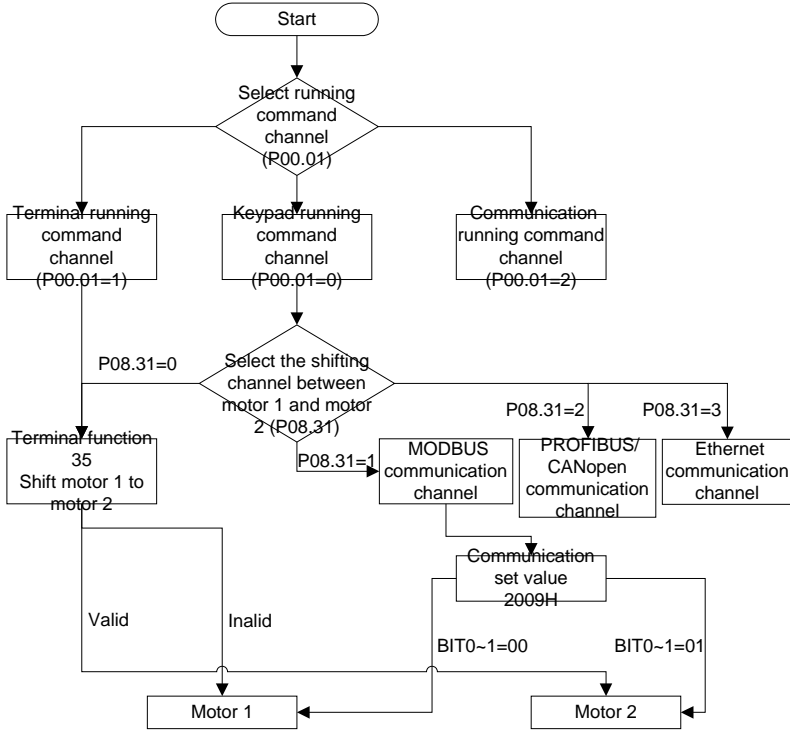

The control performance of the inverter is based on the established accurate motor model. The user has to carry out the motor autotune before first running (take motor 1 as the example).

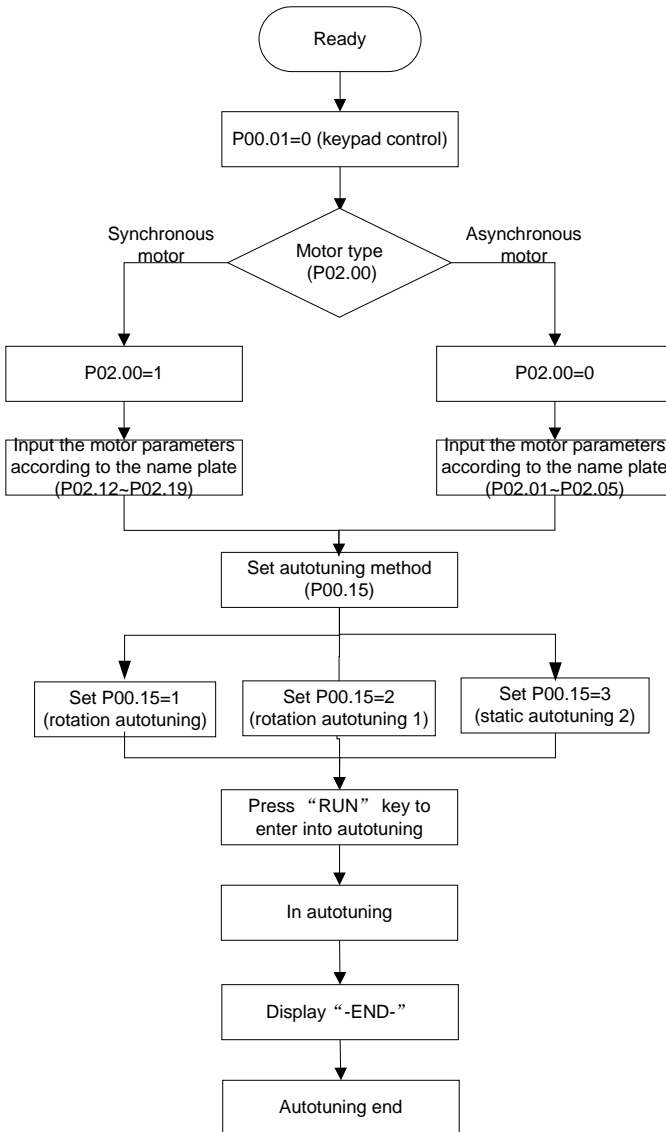

Note:

1. Set the motor parameters according to the name plate of the motor.
2. During the motor autotune, if rotation autotune is selected, de-couple the motor from the load to make the motor in a static and empty state; otherwise, the result of autotune is incorrect. The asynchronous motors can autotune the parameters of P02.06~P02.10 and the synchronous motors can autotune the parameters of P02.20~P02.23.

3. During the motor autotune, if static autotune is selected, do not de-couple the motor from the load. Because only some parameters of the motor are involved, the control performance is not as better as the rotation autotune. The asynchronous motors can autotune the parameters of P02.06~P02.10; the synchronous motors can autotune the parameters of P02.20~P02.22, P02.23 can be counted.
4. Motor autotune only involves the current motor. Switch the motor through P08.31 to carry out the autotune on the other motor.

Relative parameters list:

Function code	Name	Detailed instruction of parameters	Default value
P00.01	Running command channel	0: Keypad running command 1: Terminal running command channel ("LOCAL/REMOT" flickering) 2: Communication running command channel ("LOCAL/REMOT" on);	0
P00.15	Motor parameter autotuning	0: No operation 1: Rotation autotuning 2: Static autotuning 1 (autotune totally) 3: Static autotuning 2 (autotune partially)	0
P02.00	Motor type 1	0: Asynchronous motor 1: Synchronous motor	0
P02.01	Rated power of asynchronous motor 1	0.1~3000.0kW	Depend on model
P02.02	Rated frequency of asynchronous motor 1	0.01Hz~P00.03 (Max. output frequency)	50.00Hz
P02.03	Rated speed of asynchronous motor 1	1~36000rpm	Depend on model
P02.04	Rated voltage of asynchronous motor 1	0~1200V	Depend on model
P02.05	Rated current of asynchronous motor 1	0.8~6000.0A	Depend on model
P02.06	Stator resistor of asynchronous motor 1	0.001~65.535Ω	Depend on model
P02.07	Rotor resistor of asynchronous motor 1	0.001~65.535Ω	Depend on model
P02.08	Leakage inductance of asynchronous motor 1	0.1~6553.5mH	Depend on model
P02.09	Mutual inductance of	0.1~6553.5mH	Depend

Function code	Name	Detailed instruction of parameters	Default value
	asynchronous motor 1		on model
P02.10	Non-load current of asynchronous motor 1	0.1~6553.5A	Depend on model
P02.15	Rated power of synchronous motor 1	0.1~3000.0kW	Depend on model
P02.16	Rated frequency of synchronous motor 1	0.01Hz~P00.03 (Max. output frequency)	50.00Hz
P02.17	Number of poles pairs for synchronous motor 1	1~50	2
P02.18	Rated voltage of synchronous motor 1	0~1200V	Depend on model
P02.19	Rated current of synchronous motor 1	0.8~6000.0A	Depend on model
P02.20	Stator resistor of synchronous motor 1	0.001~65.535Ω	Depend on model
P02.21	Direct axis inductance of synchronous motor 1	0.01~655.35mH	Depend on model
P02.22	Quadrature axis inductance of synchronous motor 1	0.01~655.35mH	Depend on model
P02.23	Back EMF constant of synchronous motor 1	0~10000	300
P05.01~ P05.09	Multi-function digital input terminals (S1~S8, HDI) function selection	35: Shift from motor 1 to motor 2	
P08.31	Motor shifting	LED ones: shifting channel 0: terminal shifting 1: MODBUS communication shifting 2: PROFIBUS/CANopen communication shifting 3: Ethernet communication shifting 4: Reserved LED tens: shifting enabling in operation 0: Disabled	00

Function code	Name	Detailed instruction of parameters	Default value
		1: Enabled 0x00~0x14	
P12.00	Motor type 2	0:Asynchronous motor 1:Synchronous motor	0
P12.01	Rated power of asynchronous motor 2	0.1~3000.0kW	Depend on model
P12.02	Rated frequency of asynchronous motor 2	0.01Hz~P00.03 (Max. output frequency)	50.00Hz
P12.03	Rated speed of asynchronous motor 2	1~36000rpm	Depend on model
P12.04	Rated voltage of asynchronous motor 2	0~1200V	Depend on model
P12.05	Rated current of asynchronous motor 2	0.8~6000.0A	Depend on model
P12.06	Stator resistor of asynchronous motor 2	0.001~65.535Ω	Depend on model
P12.07	Rotor resistor of asynchronous motor 2	0.001~65.535Ω	Depend on model
P12.08	Leakage inductance of asynchronous motor 2	0.1~6553.5mH	Depend on model
P12.09	Mutual inductance of asynchronous motor 2	0.1~6553.5mH	Depend on model
P12.10	Non-load current of asynchronous motor 2	0.1~6553.5A	Depend on model
P12.15	Rated power of synchronous motor 2	0.1~3000.0kW	Depend on model
P12.16	Rated frequency of synchronous motor 2	0.01Hz~P00.03 (Max. output frequency)	50.00Hz
P12.17	Number of poles pairs for synchronous motor 2	1~50	2
P12.18	Rated voltage of synchronous motor 2	0~1200V	Depend on model
P12.19	Rated current of synchronous motor 2	0.8~6000.0A	Depend on model
P12.20	Stator resistor of	0.001~65.535Ω	Depend

Function code	Name	Detailed instruction of parameters	Default value
	synchronous motor 2		on model
P12.21	Direct axis inductance of synchronous motor 2	0.01~655.35mH	Depend on model
P12.22	Quadrature axis inductance of synchronous motor 2	0.01~655.35mH	Depend on model
P12.23	Back EMF constant of synchronous motor 2	0~10000	300

7.7 Start-up and stop control

The start-up and stop control of the inverter includes three states: start after the running command during normal powering on, start after the restarting function becomes valid during normal powering on and start after the automatic fault reset. Below is the detailed instruction for three starting methods. There are three starting methods for the inverter: start from the starting frequency directly, start after the AC braking and start after the rotation speed tracking. The user can select according to different situations to meet their needs.

For the load with big inertia, especially in the cases where the reverse rotation may occur, it is better to select starting after DC braking and then starting after rotation speed tracking.

Note: Users are suggested to adopt the direct starting method to drive synchronous motors.

1. The starting logic figure of starting after the running command during the normal powering on

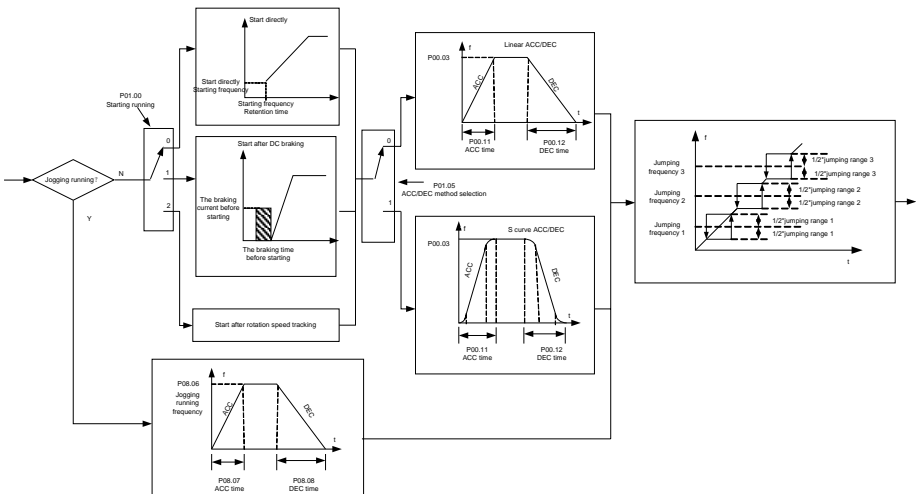

2. The starting logic figure of starting after the restarting function becomes valid during the normal

powering on

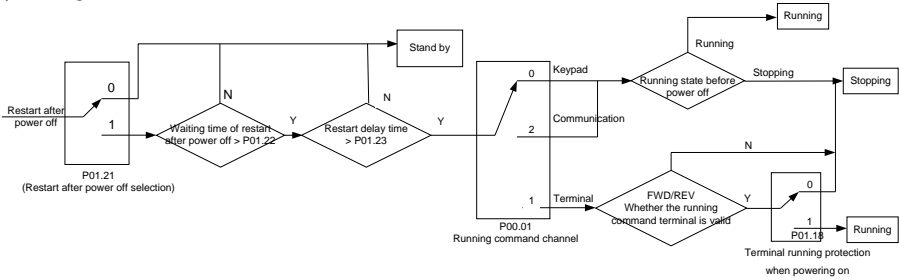

3. The starting logic figure of starting after the automatic fault reset

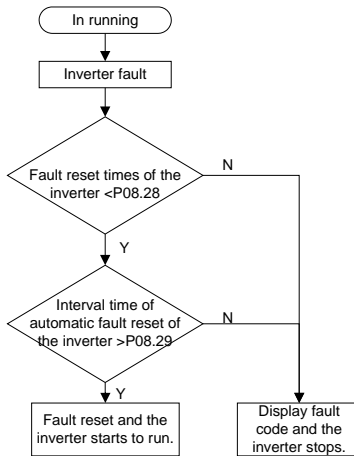

Relative parameters list:

Function code	Name	Detailed instruction of parameters	Default value
P00.01	Running command channel	0:Keypad running command 1:Terminal running command channel ("LOCAL/REMOT" flickering) 2:Communication running command channel ("LOCAL/REMOT" on);	0
P00.11	ACC time 1	0.0~3600.0s	Depend on model
P00.12	DEC time 1	0.0~3600.0s	Depend on model
P01.00	Start mode	0:Start-up directly 1:Start-up after DC braking	0

Function code	Name	Detailed instruction of parameters	Default value
		2: Start-up after speed tracing	
P01.01	Starting frequency of direct start	0.00~50.00Hz	0.50Hz
P01.02	Retention time of starting frequency	0.0~50.0s	0.0s
P01.03	The braking current before starting	0.0~100.0%	0.0%
P01.04	The braking time before starting	0.00~50.00s	0.00s
P01.05	ACC/DEC selection	0: Linear type 1: Reserved	0
P01.08	Stop mode	0: Decelerate to stop 1: Coast to stop	0
P01.09	Starting frequency of DC braking	0.00Hz~P00.03 (Max. output frequency)	0.00Hz
P01.10	Waiting time of DC braking	0.00~50.00s	0.00s
P01.11	DC braking current	0.0~100.0%	0.0%
P01.12	DC braking time	0.00~50.00s	0.00s
P01.13	Dead time of FWD/REV rotation	0.0~3600.0s	0.0s
P01.14	Shifting between FWD/REV rotation	Set the threshold point of the inverter: 0:Switch after 0 frequency 1:Switch after the starting frequency 2:Switch after the speed reaches P01.15 and delays for P01.24	0
P01.15	Stopping speed	0.00~100.00Hz	0.50 Hz
P01.16	Detection of stopping speed	0: Speed setting (the only detection method in SVPWM mode) 1: Speed detecting value	1
P01.18	Terminal running protection when powering on	0:The terminal running command is invalid when powering on 1: The terminal running command is valid when powering on	0
P01.19	Action if running	0: Run at the lower-limit frequency	0

Function code	Name	Detailed instruction of parameters	Default value
	frequency<lower limit frequency (valid>0)	1: Stop 2: Hibernation	
P01.20	Hibernation restore delay time	0.0~3600.0s(valid when P01.19=2)	0.0s
P01.21	Restart after power off	0: Disable 1: Enable	0
P01.22	The waiting time of restart after power off	0.0~3600.0s(valid when P01.21=1)	1.0s
P01.23	Start delay time	0.0~60.0s	0.0s
P01.24	Delay time of stop speed	0.0~100.0s	0.0s
P05.01~ P05.09	Digital input function selection	1: Forward rotation operation 2: Reverse rotation operation 4: Forward jogging 5: Reverse jogging 6: Coast to stop 7: Fault reset 8: Operation pause 21:ACC/DEC time 1 22:ACC/DEC time 2 30:ACC/DEC disabling	
P08.06	Jogging frequency	0.00Hz~P00.03 (Max. output frequency)	5.00Hz
P08.07	Jogging ACC time	0.0~3600.0s	Depend on model
P08.08	Jogging DEC time	0.0~3600.0s	Depend on model
P08.00	ACC time 2	0.0~3600.0s	Depend on model
P08.01	DEC time 2	0.0~3600.0s	Depend on model
P08.02	ACC time 3	0.0~3600.0s	Depend on model
P08.03	DEC time 3	0.0~3600.0s	Depend on model
P08.04	ACC time 4	0.0~3600.0s	Depend

Function code	Name	Detailed instruction of parameters	Default value
			on model
P08.05	DEC time 4	0.0~3600.0s	Depend on model
P08.28	Fault reset times	0~10	0
P08.29	Interval time of automatic fault reset	0.1~3600.0s	1.0s

7.8 Frequency setting

Goodrive300-02 series inverters can set the frequency by various means. The reference channel can be divided into main reference channel and assistant reference channel.

There are two main reference channels: A frequency reference channel and B frequency reference channel. These two reference channels can carry out mutual simple math calculation between each other. And the reference channels can be shifted dynamically through set multi-function terminals.

There are three assistant reference channels: keypad UP/DOWN input, terminals UP/DOWN switch input and digital potentiometer input. The three ways equal to the effect of input UP/DOWN reference in internal assistant reference of the inverter. The user can enable the reference method and the effect of the method to the frequency reference by setting function codes.

The actual reference of the inverter consists of main reference channel and assistant reference channel.

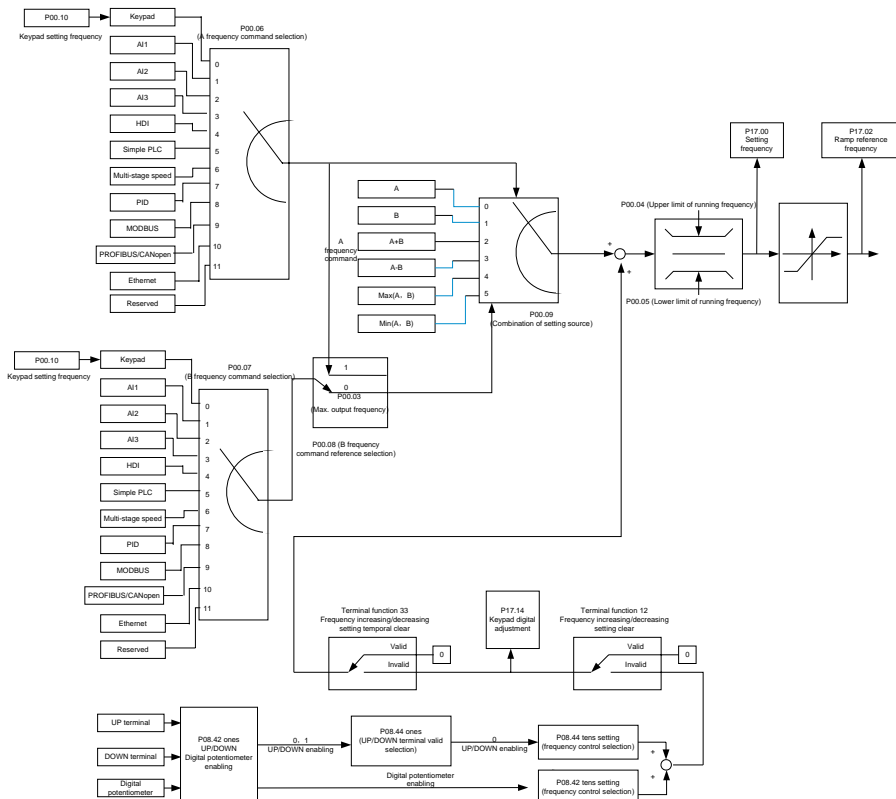

Goodrive300-02 series inverters support the shifting between different reference channels, and the detailed shifting rules is as below:

Current reference channel P00.09	Multi-function terminal function 13 Switch from A channel to B channel	Multi-function terminal function 14 Switch from combination setting to A channel	Multi-function terminal function 15 Switch from combination setting to B channel
A	B	/	/
B	/	/	/
A+B	/	A	B
A-B	/	A	B
Max(A, B)	/	A	B
Min(A, B)	/	A	B

Note: "/" means the multi-function terminal is invalid under the current reference channel.

When select multi-function terminal UP (10) and DOWN (11) to set the internal assistant frequency, P08.44 and P08.45 can be set to increase or decrease the set frequency quickly.

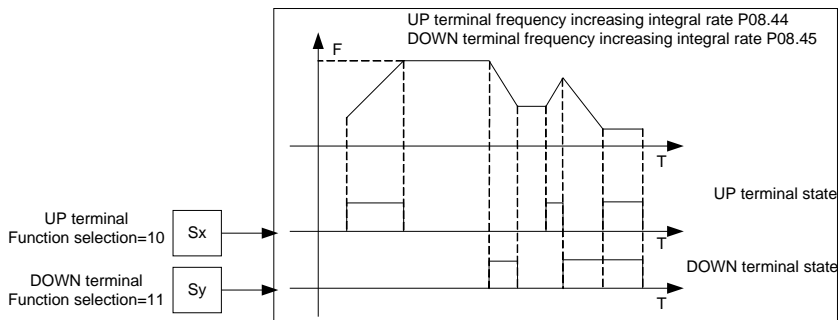

Relative parameters list:

Function code	Name	Detailed instruction of parameters	Default value
P00.03	Max. output frequency	P00.04~400.00Hz	50.00Hz
P00.04	Upper limit of running frequency	P00.05~P00.03	50.00Hz
P00.05	Lower limit of running frequency	0.00Hz~P00.04	0.00Hz
P00.06	A frequency command	0:Keypad	0
P00.07	B frequency command	1: AI1 2: AI2 3: AI3 4:High-speed pulse HDI setting 5:Simple PLC program setting 6: Multi-step speed running setting 7: PID control setting 8:MODBUS communication setting 9:PROFIBUS/CANopen communication setting 10:Ethernet communication setting(reserved) 11:Reserved	0
P00.08	B frequency command reference	0: Maximum output frequency 1: A frequency command	0
P00.09	Combination of setting source	0:A 1:B	0

Function code	Name	Detailed instruction of parameters	Default value
		2:(A+B)combination 3:(A-B)combination 4:Max(A,B)combination 5:Min(A,B)combination	
P05.01~ P05.09	Multi-function digital input terminals (S1~S8,HDI) function selection	10: Frequency setting increasing (UP) 11: Frequency setting decreasing (DOWN) 12: Frequency setting clear 13: Shift between A setting and B setting 14: Shift between combination setting and A setting 15: Shift between combination setting and B setting	
P08.42	Keypad data control	0x000~0x1223 LED ones: frequency enable selection 0:Both \wedge/\vee keys and digital potentiometer adjustments are valid 1:Only \wedge/\vee keys adjustment is valid 2:Only digital potentiometer adjustments is valid 3:Neither \wedge/\vee keys nor digital potentiometer adjustments are valid LED tens: frequency control selection 0:Only valid when P00.06=0 or P00.07=0 1:Valid for all frequency setting manner 2:Invalid for multi-step speed when multi-step speed has the priority LED hundreds: action selection during stopping 0:Setting is valid 1:Valid during running, cleared after stopping 2:Valid during running, cleared after receiving the stop command	0x0000

Function code	Name	Detailed instruction of parameters	Default value
		LED thousands: \wedge/V keys and digital potentiometer Integral function 0:The Integral function is valid 1:The Integral function is invalid	
P08.43	Integral ratio of keypad potentiometer	0.01~10.00s	0.10s
P08.44	UP/DOWN terminals control	0x000~0x221 LED ones: frequency enable selection 0: UP/DOWN terminals setting is valid 1: UP/DOWN terminals setting is invalid LED tens: frequency control selection 0: Only valid when P00.06=0 or P00.07=0 1: All frequency means are valid 2: When the multi-step speed has the priority, it is invalid to the multi-step speed LED hundreds: action selection during stopping 0: Setting is valid 1: Valid during running, clear after stop 2: Valid during running, clear after receiving the stop command	0x000
P08.45	UP terminals frequency changing ratio	0.01~50.00Hz/s	0.50Hz/s
P08.46	DOWN terminals frequency changing ratio	0.01~50.00Hz/s	0.50Hz/s
P17.00	Setting frequency	Display current set frequency of the inverter Range: 0.00Hz~P00.03	0.00Hz
P17.02	Ramp reference frequency	Display current ramp reference frequency of the inverter Range: 0.00Hz~P00.03	0.00Hz
P17.14	Digital adjustment	Display the adjustment through the	0.00Hz

Function code	Name	Detailed instruction of parameters	Default value
		keypad of the inverter. Range : 0.00Hz~P00.03	

7.9 Analog input

Goodrive300-02 series inverters have three analog input terminals and 1 high-speed pulse input terminal (of which, AI1 and AI2 are 0~10V/0~20mA and AI can select voltage input or current input by J1, A2 can select voltage input or current input by J2 and AI3 is for -10~10V) as the standard configuration. The inputs can be filtered and the maximum and minimum values can be adjusted.

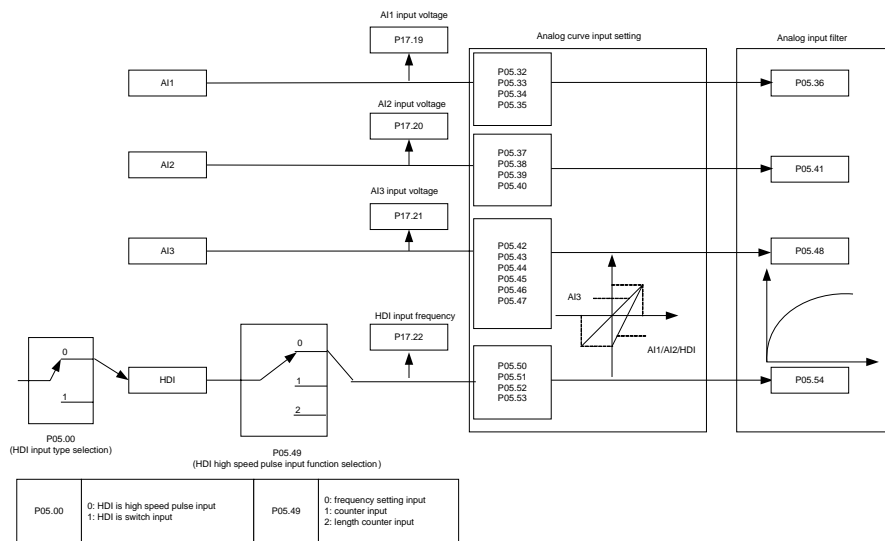

Relative parameters list:

Function code	Name	Detailed instruction of parameters	Default value
P05.00	HDI input selection	0: High-speed pulse input 1: Digital input	0
P05.32	Lower limit of AI1	0.00V~P05.34	0.00V
P05.33	Corresponding setting of the lower limit of AI1	-100.0%~100.0%	0.0%
P05.34	Upper limit of AI1	P05.32~10.00V	10.00V
P05.35	Corresponding setting of the upper limit of AI1	-100.0%~100.0%	100.0%
P05.36	AI1 input filter time	0.000s~10.000s	0.100s

Function code	Name	Detailed instruction of parameters	Default value
P05.37	Lower limit of AI2	0.00V~P05.39	0.00V
P05.38	Corresponding setting of the lower limit of AI2	-100.0%~100.0%	0.0%
P05.39	Upper limit of AI2	P05.37~10.00V	10.00V
P05.40	Corresponding setting of the upper limit of AI2	-100.0%~100.0%	100.0%
P05.41	AI2 input filter time	0.000s~10.000s	0.100s
P05.42	Lower limit of AI3	-10.00V~P05.44	-10.00V
P05.43	Corresponding setting of the lower limit of AI3	-100.0%~100.0%	-100.0%
P05.44	Middle value of AI3	P05.42~P05.46	0.00V
P05.45	Corresponding middle setting of AI3	-100.0%~100.0%	0.0%
P05.46	Upper limit of AI3	P05.44~10.00V	10.00V
P05.47	Corresponding setting of the upper limit of AI3	-100.0%~100.0%	100.0%
P05.48	AI3 input filter time	0.000s~10.000s	0.100s
P05.49	HDI high-speed pulse input function selection	0:Frequency setting input, frequency setting source 1:Counter input, high-speed pulse counter input terminals 2:Length counting input, length counter input terminals	0
P05.50	Lower limit frequency of HDI	0.000kHz~P05.52	0.000kHz
P05.51	Corresponding setting of HDI low frequency setting	-100.0%~100.0%	0.0%
P05.52	Upper limit frequency of HDI	P05.50~50.000kHz	50.000 kHz
P05.53	Corresponding setting of HDI upper limit frequency	-100.0%~100.0%	100.0%
P05.54	HDI frequency input filter time	0.000s~10.000s	0.100s

7.10 Analog output

Goodrive300-02 series inverters have 2 analog output terminals (0~10V or 0~20mA) and 1 high speed pulse output terminal. Analog output signal can be filtered and the maximum and minimum values can be adjusted. The analog output signals can be proportional to motor speed, output frequency, output current, motor torque, motor power, etc.

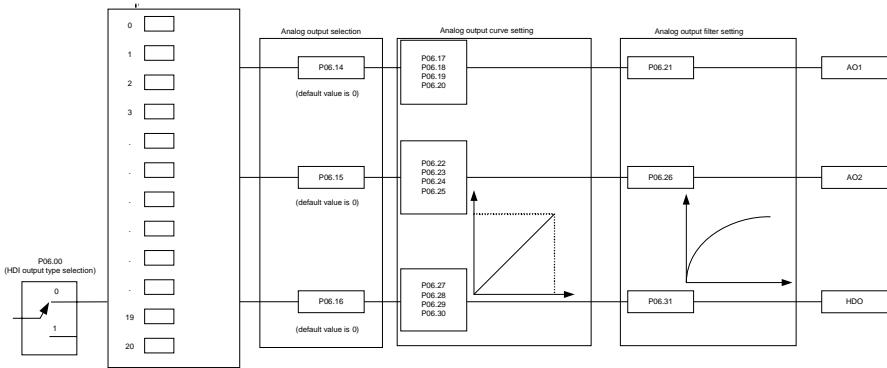

Output instructions:

Set value	Function	Instructions
0	Running frequency	0~the Max. output frequency
1	Set frequency	0~ the Max. output frequency
2	Ramp reference frequency	0~ the Max. output frequency
3	Running speed	0~2 times of the rated synchronous rotation speed of the motor
4	Output current (relative to the inverter)	0~2 times of the rated current of the inverter
5	Output current (relative to the motor)	0~2 times of the rated current of the inverter
6	Output voltage	0~1.5 times of the rated voltage of the inverter
7	Output power	0~2 times of the rated power
8	Setting torque value	0~2 times of the rated current of the motor

Set value	Function	Instructions
9	Output torque	0~2 times of the rated current of the motor
10	AI1	0~10V/0~20mA
11	AI2	0~10V/0~20mA
12	AI3	-10V~10V
13	HDI	0.00~50.00kHz
14	Setting value 1 of MODBUS communication	-1000~1000,1000 corresponds to 100.0%
15	Setting value 2 of MODBUS communication	-1000~1000,1000 corresponds to 100.0%
16	Setting value 1 of PROFIBUS/CANopen communication	-1000~1000,1000 corresponds to 100.0%
17	Setting value 2 of PROFIBUS/CANopen communication	-1000~1000,1000 corresponds to 100.0%
18	Setting value 1 of Ethernet communication	-1000~1000,1000 corresponds to 100.0%
19	Setting value 2 of Ethernet communication	-1000~1000,1000 corresponds to 100.0%
20~21	Reserved	
22	Torque current(relative to the rated current of the motor)	0~2 times of the rated current of the motor
23	Ramp reference frequency (with sign)	0~ the Max. output frequency
24~30	Reserved	

Relative parameters list:

Function code	Name	Detailed instruction of parameters	Default value
P06.00	HDO output	0: Open collector pole high speed pulse output 1: Open collector pole output.	0
P06.14	AO1 output	0:Running frequency	0
P06.15	AO2 output	1:Set frequency	0
P06.16	HDO high-speed pulse output	2:Ramp reference frequency 3:Running rotation speed 4:Output current	0

Function code	Name	Detailed instruction of parameters	Default value
		(relative to the rated current of the inverter) 5:Output current (relative to the rated current of the motor) 6:Output voltage 7:Output power 8:Set torque value 9:Output torque 10:Analog AI1 input value 11:Analog AI2 input value 12:Analog AI3 input value 13:High speed pulse HDI input value 14:MODBUS communication set value 1 15:MODBUS communication set value 2 16:PROFIBUS/CANopen communication set value 1 17:PROFIBUS/CANopen communication set value 2 18: Ethernet communication set value 1 19: Ethernet communication set value 2 20~21: Reserved 22:Torque current(relative to the rated current of the motor) 23: Ramp reference frequency (with sign) 24~30:Reserved	
P06.17	Lower output limit of AO1	-100.0%~P06.19	0.0%
P06.18	Corresponding AO1 output of lower limit	0.00V~10.00V	0.00V
P06.19	Upper output limit of AO1	P06.17~100.0%	100.0%
P06.20	Corresponding AO1 output of upper limit	0.00V~10.00V	10.00V
P06.21	AO1 output filter time	0.000s~10.000s	0.000s
P06.22	Lower output limit of AO2	-100.0%~P06.24	0.0%

Function code	Name	Detailed instruction of parameters	Default value
P06.23	Corresponding AO2 output of lower limit	0.00V~10.00V	0.00V
P06.24	Upper output limit of AO2	P06.22~100.0%	100.0%
P06.25	Corresponding AO2 output of upper limit	0.00V~10.00V	10.00V
P06.26	AO2 output filter time	0.000s~10.000s	0.000s
P06.27	Lower output limit of HDO	-100.0%~P06.29	0.00%
P06.28	Corresponding HDO output of lower limit	0.00~50.00kHz	0.0kHz
P06.29	Upper output limit of HDO	P06.27~100.0%	100.0%
P06.30	Corresponding HDO output of upper limit	0.00~50.00kHz	50.00kHz
P06.31	HDO output filter time	0.000s~10.000s	0.000s

7.11 Digital input

Goodrive300-02 series inverters have 8 programmable digital input terminals and 1 open collector input terminal in the standard configuration. All functions of the digital input terminals are programmable by the function codes. Open collector input terminal can be selected into high-speed pulse input terminal or common switch input terminal by function code. When selected into HDI, the user can select HDI high speed pulse input as frequency reference, counting input or length pulse input by setting.

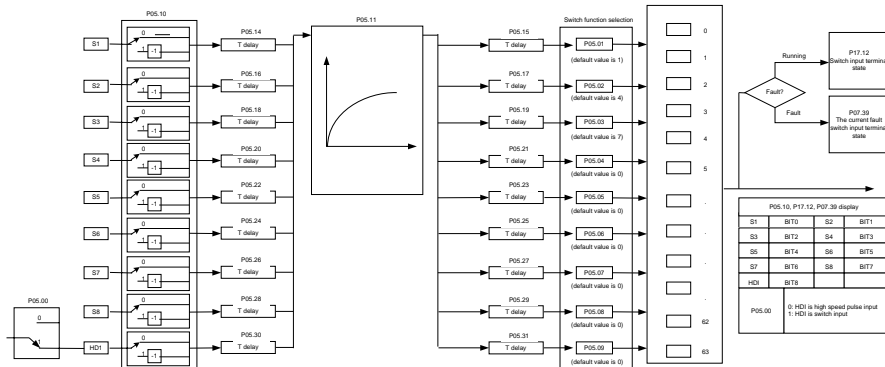

0	No function	1	Forward running	2	Reverse running	3	3-wire running control
4	Forward jogging	5	Reverse jogging	6	Coast to stop	7	Fault reset
8	Running pause	9	External fault input	10	Frequency setting increasing (UP)	11	Frequency setting decreasing (DOWN)
12	Frequency increasing/increasing setting clear	13	Shifting between A frequency and B frequency	14	Shifting between the combination setting and A frequency	15	Shifting between the combination setting and B frequency
16	Multi-stage speed terminal 1	17	Multi-stage speed terminal 2	18	Multi-stage speed terminal 3	19	Multi-stage speed terminal 4
20	Multi-stage speed pause	21	ACC/DEC time selection 1	22	ACC/DEC time selection 2	23	Simple PLC stopping reset
23	Simple PLC pause	25	PID control pause	26	Traverse pause (stop at the current frequency)	27	Traverse reset (stop at the middle frequency)
28	Counter reset	29	Torque control disabling	30	ACC/DEC disabling	31	Counter triggering
32	Length reset	33	Frequency increasing/decreasing setting clear	34	DC braking	35	Shift from motor 1 to motor 2
36	Shift the command to the keypad	37	Shift the command to the terminal	38	Shift the command to the communication	39	Pre-exciting command
40	Power consumption clear	41	Power consumption keeping	42-43	Reserved		

This parameter is used to set the function corresponding to the digital multi-function input terminals.

Note: Two different multi-function terminals cannot be set as one function.

Set value	Function	Instructions
0	No function	The inverter does not work even there is input signal. It is necessary to set the terminal which cannot be used to non-function to avoid misacting.
1	Forward running(FWD)	The forward or reverse rotation of the inverter can be controlled by the external terminals.
2	Reverse running(REV)	
3	3-wire running control	The terminal can determine the running mode of the inverter is 3-wire control mode. Refer to P05.13 for detailed instruction of 3-wire control mode.
4	Forward jogging	See P08.06, P08.07 and P08.08 for jogging frequency, jogging ACC/DEC time.
5	Reverse jogging	
6	Coast to stop	The inverter closes off the output. The motor is not controlled by the inverter during the stopping. This method is usually to be used when the load inertia is big and it has no requirement to the stopping time.

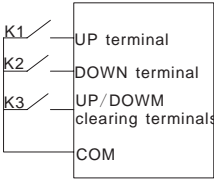
Set value	Function	Instructions
		It has the same meaning with the "coast to stop" in P01.08 and usually used in remote control.
7	Fault reset	External fault reset. It has the same function with the reset function of STOP/RST on the keypad. This function can realize remote fault reset.
8	Operation pause	The inverter decelerates to stop. But all running parameters are in the memory state. For example, PLC parameters, traverse parameters and PID parameters. After the signal disappears, the inverter will come back to the state before stopping.
9	External fault input	When the external fault signal is sent to the inverter, the inverter will report the fault and stop.
10	Frequency setting up(UP)	This parameter is used to modify the increasing and decreasing command during the external terminal reference frequency.
11	Frequency setting down(DOWN)	
12	Frequency increasing/decreasing setting clear	 <p>Frequency increasing/decreasing setting clear terminal can cancel the assistant channel frequency set by the internal UP/DOWN of the inverter to make the reference frequency restore to the frequency given by the main reference frequency channel.</p>
13	Switch between A setting and B setting	This function can realize the shifting between the frequency setting channels.
14	Switch between A setting and combination setting	The 13 th function can realize the shifting between A frequency reference channel and B frequency reference channel.
15	Switch between B setting and combination setting	The 14 th function can realize the shifting between A frequency reference channel and the combination setting channel set by P00.09

Set value	Function	Instructions			
		The 15 th function can realize the shifting between B frequency reference channel and the combination setting channel set by P00.09			
16	Multi-step speed terminal 1	The 16 stage speeds can be set by the combination of digital state of four terminals. Note: multi-step speed 1 is the low bit, multi-step speed 4 is the high bit.			
17	Multi-step speed terminal 2				
18	Multi-step speed terminal 3				
19	Multi-step speed terminal 4	Multi-step speed 4	Multi-step speed 3	Multi-step speed 2	Multi-step speed 1
		<input type="checkbox"/> BIT3	<input type="checkbox"/> BIT2	<input type="checkbox"/> BIT1	<input type="checkbox"/> BIT0
20	Multi-step speed pause	Shield the multi-step speed selection terminal function to keep the setting value at the current state.			
21	ACC/DEC time selection 1	Select 4 ACC/DEC time by the combination of the 2 terminals.			
22	ACC/DEC time selection 2	Terminal 1	Terminal 2	ACC/DEC time selection	Corresponding parameter
		OFF	OFF	ACC/DEC time 1	P00.11/P00.12
		ON	OFF	ACC/DEC time 2	P08.00/P08.01
		OFF	ON	ACC/DEC time 3	P08.02/P08.03
		ON	ON	ACC/DEC time 4	P08.04/P08.05
23	Simple PLC stop reset	Restart simple PLC and clear the memory state of PLC.			
24	Simple PLC pause	Program pause during PLC implement. Run at the current speed stage. After cancel the function, simple PLC continues to run.			
25	PID control pause	Temporal PID invalid and the inverter will output at the current frequency.			
26	Traverse pause (stop at the current frequency)	The inverter will stop at the current output and after canceling the function, the inverter will continue to traverse run at the current frequency.			
27	Traverse reset (return to the middle frequency)	The setting frequency of the inverter will come back to the middle frequency.			
28	Counter reset	Counter clear			

Set value	Function	Instructions
29	Torque control disabling	The inverter shifts from torque control mode to speed control mode.
30	ACC/DEC disabling	Ensure the inverter will not be affected by the external signals (except for the stopping command) and keep the current output frequency.
31	Counter triggering	Enable the pulse counter.
32	Length reset	Length counter clear
33	Frequency increasing/decreasing setting temporal clear	When the terminal closes, the frequency set by UP/DOWN can be cleared. All set frequency will be restored into the reference frequency by the frequency command channel and the frequency will come back to the value after the frequency increasing or decreasing.
34	DC braking	The inverter will begin DC braking after the valid command.
35	Switch between motor1 and motor2	Motor-shifting can be controlled after the terminal is valid.
36	Switch commands to keypad	After the function terminal become valid, the running command channel will be shifted into keypad running command channel and the running command channel will come back to the original state if the function terminal is invalid.
37	Switch commands to terminals	After the function terminal become valid, the running command channel will be shifted into terminal running command channel and the running command channel will come back to the original state if the function terminal is invalid.
38	Switch commands to communication	After the function terminal become valid, the running command channel will be shifted into communication running command channel and the running command channel will come back to the original state if the function terminal is invalid.
39	Pre-excitation commands	Perform pre-exciting if the terminal is valid until the

Set value	Function	Instructions
		terminal is invalid.
40	Power consumption clear	The power consumption will be cleared after the command is valid.
41	Power consumption retention	If the command is valid, the current running of the inverter will not affect its power consumption.
42~60	Reserved	
61	PID pole switching	Switch the output pole of PID and be used with P09.03
62~63	Reserved	

Relative parameters list:

Function code	Name	Detailed instruction of parameters	Default value
P05.00	HDI input selection	0: High pulse input 1: Digital input	0
P05.01	S1 terminals function selection	0: No function	1
P05.02	S2 terminals function selection	1: Forward rotation operation 2: Reverse rotation operation 3: 3-wire control operation	4
P05.03	S3 terminals function selection	4: Forward jogging 5: Reverse jogging	7
P05.04	S4 terminals function selection	6: Coast to stop 7: Fault reset	0
P05.05	S5 terminals function selection	8: Operation pause 9: External fault input	0
P05.06	S6 terminals function selection	10: Increasing frequency setting(UP) 11: Decreasing frequency	0
P05.07	S7 terminals function selection	setting(DOWN) 12: Frequency setting clear	0
P05.08	S8 terminals function selection	13: Shift between A setting and B setting 14: Shift between combination setting and A setting	0
P05.09	HDI terminal function selection	15: Shift between combination setting and B setting 16: Multi-step speed terminal 1 17: Multi-step speed terminal 2	0

Function code	Name	Detailed instruction of parameters	Default value
		18:Multi-step speed terminal 3 19:Multi- step speed terminal 4 20:Multi- step speed pause 21:ACC/DEC time 1 22:ACC/DEC time 2 23:Simple PLC stop reset 24:Simple PLC pause 25:PID control pause 26:Traverse pause(stop at the current frequency) 27:Traverse reset(return to the center frequency) 28:Counter reset 29:Torque control disabling 30:ACC/DEC disabling 31:Counter triggering 32:Length reset 33:Cancel the frequency change setting temporarily 34:DC brake 35:Shift the motor 1 into motor 2 36:Shift the command to the keypad 37:Shift the command to the terminals 38:Shift the command to the communication 39:Pre-magnetized command 40:Consumption power clear 41: Consumption power holding 42~60:Reserved 61:PID pole switching 62~63: Reserved	
P05.10	Polarity selection of the input terminals	0x000~0x1FF	0x000
P05.11	ON-OFF filter time	0.000~1.000s	0.010s
P05.12	Virtual terminals setting	0x000~0x1FF(0: Disabled, 1:Enabled) BIT0:S1 virtual terminal	0

Function code	Name	Detailed instruction of parameters	Default value
		BIT1:S2 virtual terminal BIT2:S3 virtual terminal BIT3:S4 virtual terminal BIT4:S5 virtual terminal BIT5:S6 virtual terminal BIT6:S7 virtual terminal BIT7:S8 virtual terminal BIT8:HDI virtual terminal	
P05.13	Terminals control running mode	0:2-wire control 1 1:2-wire control 2 2:3-wire control 1 3:3-wire control 2	0
P05.14	Switch-on delay of S1 terminal	0.000~50.000s	0.000s
P05.15	Switch-off delay of S1 terminal	0.000~50.000s	0.000s
P05.16	Switch-on delay of S2 terminal	0.000~50.000s	0.000s
P05.17	Switch-off delay of S2 terminal	0.000~50.000s	0.000s
P05.18	Switch-on delay of S3 terminal	0.000~50.000s	0.000s
P05.19	Switch-off delay of S3 terminal	0.000~50.000s	0.000s
P05.20	Switch-on delay of S4 terminal	0.000~50.000s	0.000s
P05.21	Switch-off delay of S4 terminal	0.000~50.000s	0.000s
P05.22	Switch-on delay of S5 terminal	0.000~50.000s	0.000s
P05.23	Switch-off delay of S5 terminal	0.000~50.000s	0.000s
P05.24	Switch-on delay of S6 terminal	0.000~50.000s	0.000s
P05.25	Switch-off delay of S6 terminal	0.000~50.000s	0.000s

Function code	Name	Detailed instruction of parameters	Default value
	terminal		
P05.26	Switch-on delay of S7 terminal	0.000~50.000s	0.000s
P05.27	Switch-off delay of S7 terminal	0.000~50.000s	0.000s
P05.28	Switch-on delay of S8 terminal	0.000~50.000s	0.000s
P05.29	Switch-off delay of S8 terminal	0.000~50.000s	0.000s
P05.30	Switch-on delay of HDI terminal	0.000~50.000s	0.000s
P05.31	Switch-off delay of HDI terminal	0.000~50.000s	0.000s
P07.39	Input terminals state at current fault		0
P17.12	Digital input terminals state		0

7.12 Digital output

Goodrive300-02 series inverters have 2 relay output terminals, 1 open collector Y output terminal and 1 high-speed pulse output terminal in the standard configuration. All functions of the digital input terminals are programmable by the function codes. The high-speed pulse output terminal HDO can be selected into high-speed pulse output terminal or switch output terminal by function code.

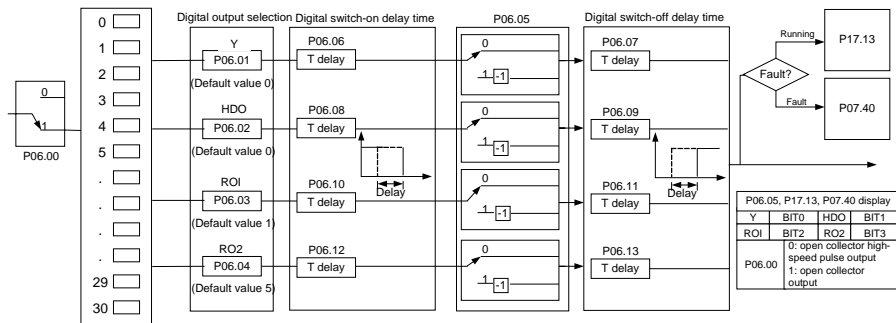

0	Invalid	1	Running	2	Forward running
3	Reverse running	4	Jogging	5	Inverter fault
6	FDT1	7	FDT2	8	Frequency arrival
9	Zero- speed running	10	Upper-limit frequency arrival	11	Lower-limit frequency arrival
12	Ready	13	Pre-exciting	14	Overload pre-alarm
15	Underload pre-alarm	16	Simple PLC stage completion	17	Simple PLC cycle completion
18	Set counting arrival	19	Fixed counting arrival	20	External fault valid
21	Length arrival	22	Running time arrival	23	MODBUS communication virtual terminal output
24	PROFIBUS/CANopen communication virtual terminal output	25	Ethernet communication virtual terminal output	26	Voltage establishment finished
27-30	Reserved				

The below table is the option of the four function parameters and selecting the repeated output terminal function is allowed.

Set value	Function	Instructions
0	Invalid	The output terminal has no function.
1	Running	Output ON signal when the inverter is running and there is frequency output.
2	Forward running	Output ON signal when the inverter is running forward and there is frequency output.
3	Reverse running	Output ON signal when the inverter is running reverse and there is frequency output.
4	Jogging	Output ON signal when the inverter is jogging and there is frequency output.
5	Inverter fault	Output ON signal when the inverter is in fault
6	FDT1	Please refer to P08.32 and P08.33 for detailed information.
7	FDT2	Please refer to P08.34 and P08.35 for detailed information.
8	Frequency arrival	Please refer to P08.36 for detailed information.
9	Zero-speed running	Output ON signal when the output frequency and reference frequency of the inverter is 0 at the same time.

Set value	Function	Instructions
10	Upper-limit frequency arrival	Output ON signal when the running frequency of the inverter is the upper limit frequency.
11	Upper-limit frequency arrival	Output ON signal when the running frequency of the inverter is the lower limit frequency.
12	Ready	When the main circuit and the control circuit is established and the protection function of the inverter is not active. The inverter is in the running state and it will output ON signal.
13	Pre-exciting	Output ON signal when the inverter is in the pre-exciting state.
14	Overload pre-alarm	Output ON signal if the inverter is beyond the pre-alarm point. Refer to P11.08~P11.10 for the detailed instruction.
15	Underload pre-alarm	Output ON signal if the inverter is beyond the pre-alarm point. Refer to P11.11~P11.12 for the detailed instruction.
16	Simple PLC stage completion	Output signal if the simple PLC stage is completed.
17	Simple PLC cycle completion	Output signal if the simple PLC cycle is completed.
18	Set counting arrival	Output ON signal if the detected counting exceeds the set value of P08.25.
19	Fixed counting arrival	Output ON signal if the detected counting exceeds the set value of P08.26.
20	External fault valid	Output ON signal if external fault occurs.
21	Length arrival	Output ON signal if the actual detected length exceeds the set length by P08.19.
22	Running time arrival	Output ON signal if the accumulative running time of the inverter exceeds the setting time by P08.27.
23	MODBUS communication virtual terminal output	Output corresponding signal according to the setting value of MODBUS. Output ON signal if the setting value is 1 and output OFF signal if the setting value is 0.
24	PROFIBUS/CANopen communication virtual terminal output	Output corresponding signal according to the setting value of PROFIBUS/CANopen. Output ON signal if the setting value is 1 and output OFF signal if the setting value is 0.

Set value	Function	Instructions
25	Ethernet communication virtual terminal output	Output corresponding signal according to the setting value of Ethernet. Output ON signal if the setting value is 1 and output OFF signal if the setting value is 0.
26	Voltage establishment finished	The output is valid when the bus voltage reaches the undervoltage point.
27~30	Reserved	

Relative parameters list:

Function code	Name	Detailed instruction of parameters	Default value
P06.00	HDO output	0:Open collector high-speed pulse output 1: Open collector output	0
P06.01	Y output	0:Invalid	0
P06.02	HDO output	1:In operation	0
P06.03	Relay RO1 output	2:Forward rotation operation	1
P06.04	Relay RO2 output	3:Reverse rotation operation 4: Jogging operation 5:Inverter fault 6:Frequency degree test FDT1 7:Frequency degree test FDT2 8:Frequency arrival 9:Zero speed running 10:Upper limit frequency arrival 11:Lower limit frequency arrival 12:Ready for operation 13:Pre-magnetizing 14:Overload pre-alarm 15: Underload pre-alarm 16:Completion of simple PLC stage 17:Completion of simple PLC cycle 18:Setting count value arrival 19:Reference count value arrival 20:External fault valid 21:Length arrival	5

Function code	Name	Detailed instruction of parameters	Default value
		22:Running time arrival 23:MODBUS communication virtual terminals output 24:PROFIBUS/CANopen communication virtual terminals output 25: Ethernet communication virtual terminals output 26: Completion of DC bus voltage setting 27~30: Reserved	
P06.05	Polarity of output terminals	0x00~0x0F	0x00
P06.06	Y switch-on delay time	0.000~50.000s	0.000s
P06.07	Y switch-off delay time	0.000~50.000s	0.000s
P06.08	HDO switch-on delay time	0.000~50.000s (valid only when P06.00=1)	0.000s
P06.09	HDO switch-off delay time	0.000~50.000s (valid only when P06.00=1)	0.000s
P06.10	RO1 switch-on delay time	0.000~50.000s	0.000s
P06.11	RO1 switch-off delay time	0.000~50.000s	0.000s
P06.12	RO2 switch-on delay time	0.000~50.000s	0.000s
P06.13	RO2 switch-off delay time	0.000~50.000s	0.000s
P07.40	Output terminals state at current fault		0
P17.13	Digital output terminals state		0

7.13 Simple PLC

Simple PLC function is also a multi-step speed generator. The inverter can change the running frequency, direction to meet the need of processing according to the running time automatically. In the past, this function needs to be assisted by external PLC, but now the inverter can realize this function by itself.

The series inverters can control 16-stage speed with 4 groups of ACC/DEC time.

The multi-function digital output terminals or multi-function relay output an ON signal when the set PLC finishes a circle (or a stage).

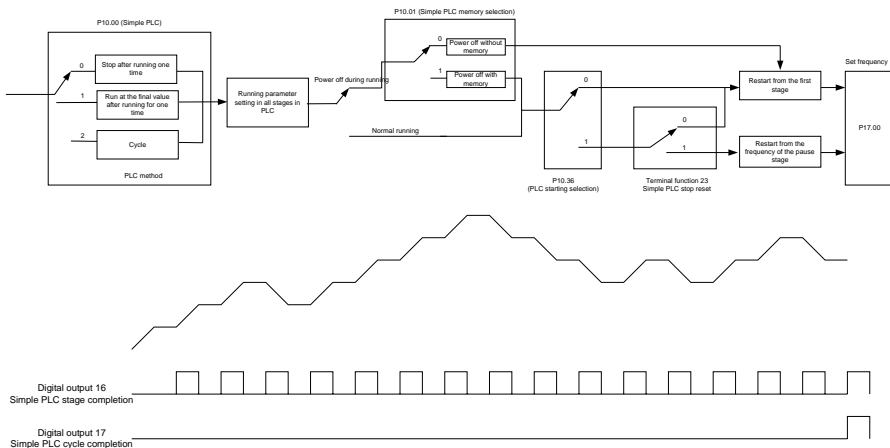

Relative parameters list:

Function code	Name	Detailed instruction of parameters	Default value
P10.00	Simple PLC	0:Stop after running once 1:Run at the final value after running once 2:Cycle running	0
P10.01	Simple PLC memory	0:Power loss without memory 1:Power loss memory	0
P10.02	Multi-step speed 0	-100.0~100.0%	0.0%
P10.03	The running time of step 0	0.0~6553.5s(min)	0.0s
P10.04	Multi-step speed 1	-100.0~100.0%	0.0%
P10.05	The running time of step 1	0.0~6553.5s(min)	0.0s
P10.06	Multi-step speed 2	-100.0~100.0%	0.0%
P10.07	The running time of step 2	0.0~6553.5s(min)	0.0s
P10.08	Multi-step speed 3	-100.0~100.0%	0.0%
P10.09	The running time of step 3	0.0~6553.5s(min)	0.0s
P10.10	Multi-step speed 4	-100.0~100.0%	0.0%
P10.11	The running time of step 4	0.0~6553.5s(min)	0.0s
P10.12	Multi-step speed 5	-100.0~100.0%	0.0%
P10.13	The running time of step 5	0.0~6553.5s(min)	0.0s
P10.14	Multi-step speed 6	-100.0~100.0%	0.0%
P10.15	The running time of step 6	0.0~6553.5s(min)	0.0s

Function code	Name	Detailed instruction of parameters	Default value
P10.16	Multi-step speed 7	-100.0~100.0%	0.0%
P10.17	The running time of step 7	0.0~6553.5s(min)	0.0s
P10.18	Multi-step speed 8	-100.0~100.0%	0.0%
P10.19	The running time of step 8	0.0~6553.5s(min)	0.0s
P10.20	Multi-step speed 9	-100.0~100.0%	0.0%
P10.21	The running time of step 9	0.0~6553.5s(min)	0.0s
P10.22	Multi-step speed 10	-100.0~100.0%	0.0%
P10.23	The running time of step 10	0.0~6553.5s(min)	0.0s
P10.24	Multi-step speed 11	-100.0~100.0%	0.0%
P10.25	The running time of step 11	0.0~6553.5s(min)	0.0s
P10.26	Multi-step speed 12	-100.0~100.0%	0.0%
P10.27	The running time of step 12	0.0~6553.5s(min)	0.0s
P10.28	Multi-step speed 13	-100.0~100.0%	0.0%
P10.29	The running time of step 13	0.0~6553.5s(min)	0.0s
P10.30	Multi-step speed 14	-100.0~100.0%	0.0%
P10.31	The running time of step 14	0.0~6553.5s(min)	0.0s
P10.32	Multi-step speed 15	-100.0~100.0%	0.0%
P10.33	The running time of step 15	0.0~6553.5s(min)	0.0s
P10.36	PLC restart	0:Restart from the first stage 1:Continue to run from the stop frequency	0
P10.34	Simple PLC 0~7 step ACC/DEC time	0x0000~0xFFFF	0000
P10.35	Simple PLC 8~15 step ACC/DEC time	0x0000~0xFFFF	0000
P05.01~ P05.09	Digital input function selection	23:Simple PLC stop reset 24:Simple PLC pause 25:PID control pause	
P06.01~ P06.04	Digital output function selection	16:Completion of simple PLC stage 17:Completion of simple PLC cycle	
P17.00	Setting frequency	0.00Hz~P00.03 (Max. output frequency)	0.00Hz
P17.27	Simple PLC and current step of the multi-step speed	0~15	0

7.14 Multi-step speed running

Set the parameters when the inverter carries out multi-step speed running. Goodrive300-02 series inverters can set 16 stages speed which can be selected by the combination code of multi-step speed terminals 1~4. They correspond to multi-step speed 0 to 15.

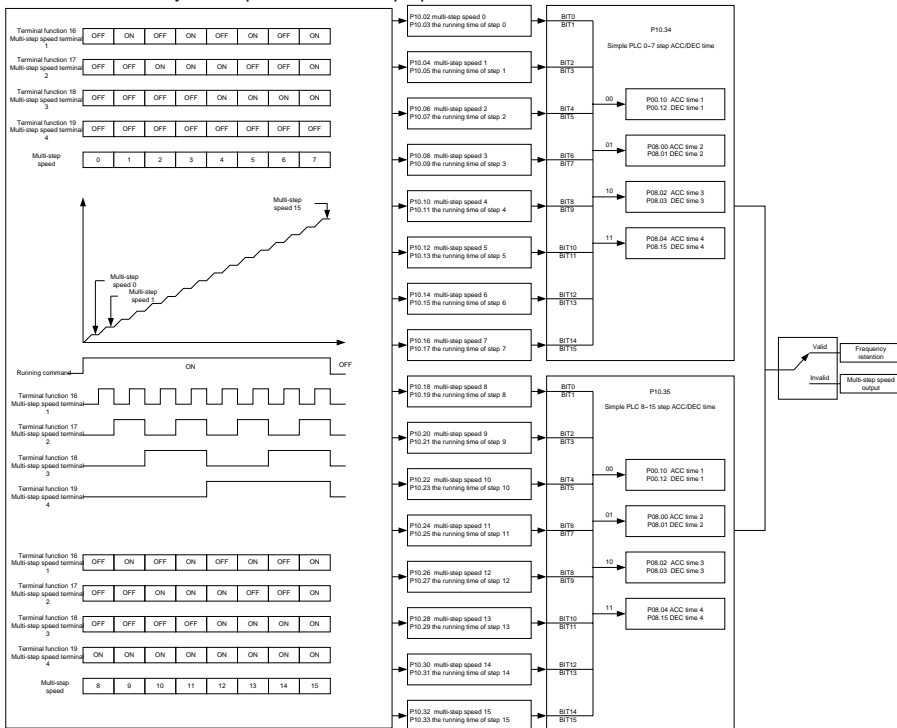

Relative parameters list:

Function code	Name	Detailed instruction of parameters	Default value
P10.02	Multi-step speed 0	-100.0~100.0%	0.0%
P10.03	The running time of step 0	0.0~6553.5s(min)	0.0s
P10.04	Multi-step speed 1	-100.0~100.0%	0.0%
P10.05	The running time of step 1	0.0~6553.5s(min)	0.0s
P10.06	Multi-step speed 2	-100.0~100.0%	0.0%
P10.07	The running time of step 2	0.0~6553.5s(min)	0.0s
P10.08	Multi-step speed 3	-100.0~100.0%	0.0%
P10.09	The running time of step 3	0.0~6553.5s(min)	0.0s
P10.10	Multi-step speed 4	-100.0~100.0%	0.0%
P10.11	The running time of step 4	0.0~6553.5s(min)	0.0s

Function code	Name	Detailed instruction of parameters	Default value
P10.12	Multi-step speed 5	-100.0~100.0%	0.0%
P10.13	The running time of step 5	0.0~6553.5s(min)	0.0s
P10.14	Multi-step speed 6	-100.0~100.0%	0.0%
P10.15	The running time of step 6	0.0~6553.5s(min)	0.0s
P10.16	Multi-step speed 7	-100.0~100.0%	0.0%
P10.17	The running time of step 7	0.0~6553.5s(min)	0.0s
P10.18	Multi-step speed 8	-100.0~100.0%	0.0%
P10.19	The running time of step 8	0.0~6553.5s(min)	0.0s
P10.20	Multi-step speed 9	-100.0~100.0%	0.0%
P10.21	The running time of step 9	0.0~6553.5s(min)	0.0s
P10.22	Multi-step speed 10	-100.0~100.0%	0.0%
P10.23	The running time of step 10	0.0~6553.5s(min)	0.0s
P10.24	Multi-step speed 11	-100.0~100.0%	0.0%
P10.25	The running time of step 11	0.0~6553.5s(min)	0.0s
P10.26	Multi-step speed 12	-100.0~100.0%	0.0%
P10.27	The running time of step 12	0.0~6553.5s(min)	0.0s
P10.28	Multi-step speed 13	-100.0~100.0%	0.0%
P10.29	The running time of step 13	0.0~6553.5s(min)	0.0s
P10.30	Multi-step speed 14	-100.0~100.0%	0.0%
P10.31	The running time of step 14	0.0~6553.5s(min)	0.0s
P10.32	Multi-step speed 15	-100.0~100.0%	0.0%
P10.33	The running time of step 15	0.0~6553.5s(min)	0.0s
P10.34	Simple PLC 0~7 step ACC/DEC time	0x0000~0XFFFF	0000
P10.35	Simple PLC 8~15 step ACC/DEC time	0x0000~0XFFFF	0000
P05.01~ P05.09	Digital input function selection	16:Multi-step speed terminal 1 17:Multi-step speed terminal 2 18:Multi-step speed terminal 3 19:Multi-step speed terminal 4 20:Multi-step speed pause	
P17.27	Simple PLC and current step of the multi-step speed	0~15	0

7.15 PID control

PID control is commonly used to control the procedure through the controlled procedure. Adjust the output frequency by proportional, integral, differential operation with the dispersion of the target signals to stabilize the value on the target. It is possible to apply to the flow, pressure and temperature control. Figure of basic control is as below:

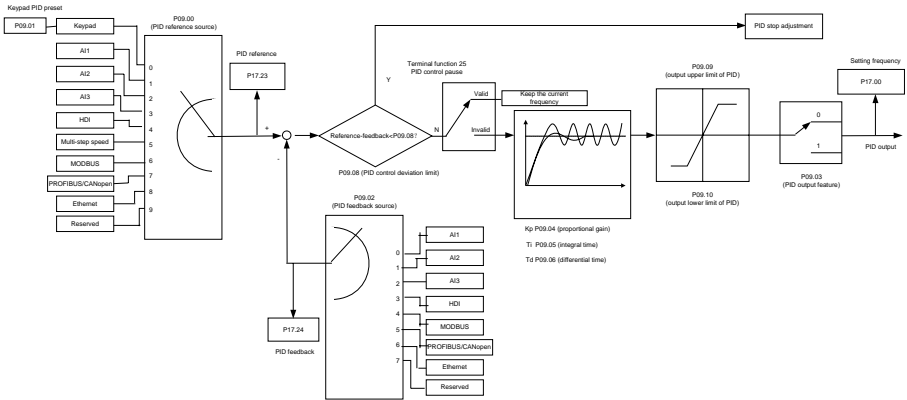

Simple illustration of the PID control operation and adjustment:

Proportional adjustment (Kp): when there is an error between the feedback and the reference, a proportional adjustment will be output. If the error is constant, the adjustment will be constant, too. Proportional adjustment can respond to the feedback change quickly, but it cannot realize non-fault control. The gain will increase with the adjustment speed, but too much gain may cause vibration. The adjustment method is: set a long integral time and derivative time to 0 first. Secondly make the system run by proportional adjustment and change the reference. And then watch the error of the feedback signal and the reference. If the static error is available (for example, increasing the reference, the feedback will be less than the reference after a stable system), continue to increase the gain, vice versa. Repeat the action until the static error achieves a little value.

Integral time (Ti): the output adjustment will accumulate if there is an error between the feedback and the reference. The adjustment will keep on increasing until the error disappears. If the error is existent all the time, the integration adjustor can cancel the static error effectively. Vibration may occur as a result of unstable system caused by repeated over-adjustment if the integration adjustor is too strong. The features of this kind of vibration are: the fluctuating feedback signal (around the reference) and increasing traverse range will cause vibration. Adjust the integral time parameter from a big value to a little one to change the integral time and monitor the result until a stable system speed is available.

Derivative time (Td): when the error between the feedback and the reference, a proportional adjustment will be output. The adjustment only depends on the direction and value of the error change other than the error itself. The derivation adjustment controls the change of feedback signals

according to the changing trend when it fluctuates. Because the derivation may enlarge the interference to the system, especially the frequent-changing interference, please use it carefully.

When P00.06, P00.07=7 or P04.27=6, the running mode of the inverter is procedure PID control.

7.15.1 General steps of PID parameters setting:

a Ensure the gain P

When ensure the gain P, firstly cancel the PID integration and derivation (set $T_i=0$ and $T_d=0$, see the PID parameter setting for detailed information) to make proportional adjustment is the only method to PID. Set the input as 60%~70% of the permitted Max. Value and increase gain P from 0 until the system vibration occurs, vice versa, and record the PID value and set it to 60%~70% of the current value. Then the gain P commission is finished.

b Ensure the integral time T_i

After ensuring the gain P, set an original value of a bigger integral time and decrease it until the system vibration occurs, vice versa, until the system vibration disappear. Record the T_i and set the integral time to 150%~180% of the current value. Then integral time commission is finished.

c Ensure the derivative time T_d

Generally, it is not necessary to set T_d which is 0.

If it needs to be set, set it to 30% of the value without vibration via the same method with P and T_i .

d Commission the system with and without load and then adjust the PID parameter until it is available.

7.15.2 PID inching

After setting the PID control parameters, inching is possible by following means:

Control the overshoot

Shorten the derivative time and prolong the integral time when overshoot occurs.

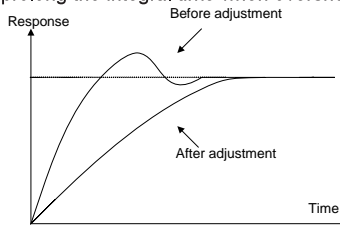

Achieve the stable state as soon as possible

Shorten the integral time (T_i) and prolong the derivative time (T_d) even the overshoot occurs, but the control should be stable as soon as possible.

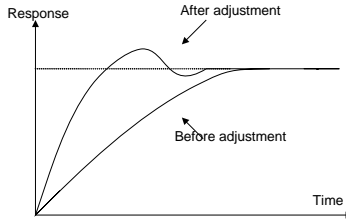

Control long vibration

If the vibration periods are longer than the set value of integral time (Ti), it is necessary to prolong the integral time (Ti) to control the vibration for the strong integration.

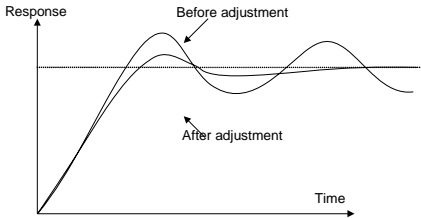

Control short vibration

Short vibration period and the same set value with the derivative time (Td) mean that the derivative time is strong. Shortening the derivative time (Td) can control the vibration. When setting the derivative time as 0.00 (ire no derivation control) is useless to control the vibration, decrease the gain.

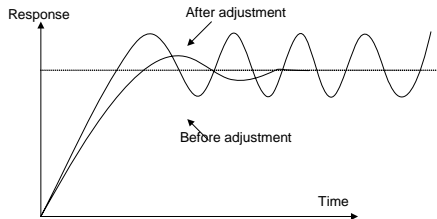

Relative parameters list:

Function code	Name	Detailed instruction of parameters	Default value
P09.00	PID reference source	0:Keypad (P09.01) 1: AI1 2: AI2 3: AI3 4: HDI 5:Multi-step speed set 6:MODBUS communication set 7:PROFIBUS/CANopen communication set	0

Function code	Name	Detailed instruction of parameters	Default value
		8:Ethernet communication set 9:Reserved	
P09.01	Keypad PID preset	-100.0%~100.0%	0.0%
P09.02	PID feedback source	0: AI1 1: AI2 2: AJ3 3: HDI 4:MODBUS communication feedback 5:PROFIBUS/CANopen communication feedback 6:Ethernet communication feedback 7:Reserved	0
P09.03	PID output feature	0:PID output is positive 1:PID output is negative	0
P09.04	Proportional gain (Kp)	0.00~100.00	1.00
P09.05	Integral time(Ti)	0.00~10.00s	0.10s
P09.06	Differential time(Td)	0.00~10.00s	0.00s
P09.07	Sampling cycle(T)	0.000~10.000s	0.100s
P09.08	PID control deviation limit	0.0~100.0%	0.0%
P09.09	Output upper limit of PID	P09.10~100.0% (Max. frequency or the Max. voltage)	100.0%
P09.10	Output lower limit of PID	-100.0%~P09.09 (Max. frequency or the Max. voltage)	0.0%
P09.11	Detection value of feedback offline	0.0~100.0%	0.0%
P09.12	Detection time of feedback offline	0.0~3600.0s	1.0s
P09.13	PID adjustment	0x0000~0x1111 LED ones: 0: Keep on integral adjustment when the frequency achieves the upper and low limit; the integration shows the change between the reference and the feedback	0x0001

Function code	Name	Detailed instruction of parameters	Default value
		<p>unless it reaches the internal integral limit. When the trend between the reference and the feedback changes, it needs more time to offset the impact of continuous working and the integration will change with the trend.</p> <p>1: Stop integral adjustment when the frequency achieves the upper and low limit. If the integration keeps stable, and the trend between the reference and the feedback changes, the integration will change with the trend quickly.</p> <p>LED tens: P00.08 is 0</p> <p>0: The same with the setting direction; if the output of PID adjustment is different from the current running direction, the internal will output 0 forcedly.</p> <p>1: Opposite to the setting direction</p> <p>LED hundreds: P00.08 is 0</p> <p>0: Limit to the maximum frequency</p> <p>1: Limit to frequency A</p> <p>LED thousands:</p> <p>0: A+B frequency, the buffer of A frequency is invalid</p> <p>1: A+B frequency, the buffer of A frequency is valid</p> <p>ACC/DEC is determined by ACC time 4 of P08.04</p>	
P17.00	Setting frequency	0.00Hz~P00.03 (Max. output frequency)	0.00Hz
P17.23	PID reference	-100.0~100.0%	0.0%
P17.24	PID feedback	-100.0~100.0%	0.0%

7.16 Traverse running

Traverse is applied in some industries such as textile, chemical fiber and cases where traverse and

convolution is required. The working flowchart is as below:

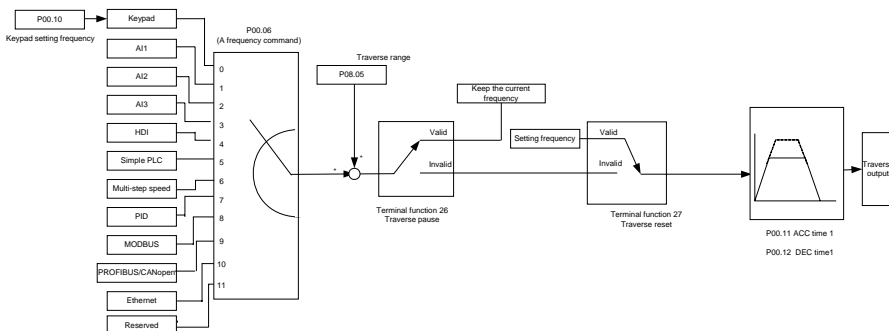

Function code	Name	Detailed instruction of parameters	Default value
P00.03	Max. output frequency	P00.03~400.00Hz	50.00Hz
P00.06	A frequency command	0:Keypad 1: AI1 2: AI2 3: AI3 4:High-speed pulse HDI setting 5:Simple PLC program setting 6: Multi-step speed running setting 7: PID control setting 8:MODBUS communication setting 9:PROFIBUS/CANopen communication setting 10:Ethernet communication setting 11:Reserved	0
P00.11	ACC time 1	0.0~3600.0s	Depend on model
P00.12	DEC time 1	0.0~3600.0s	Depend on model
P05.01~P05.09	Digital input function selection	26:Traverse pause (stop at the current frequency) 27:Traverse reset (return to the center frequency)	

Function code	Name	Detailed instruction of parameters	Default value
P08.15	Traverse range	0.0~100.0%(relative to the set frequency)	0.0%
P08.16	Sudden jumping frequency range	0.0~50.0%(relative to the traverse range)	0.0%
P08.17	Traverse boost time	0.1~3600.0s	5.0s
P08.18	Traverse declining time	0.1~3600.0s	5.0s

7.17 Pulse counter

Goodrive300-02 series inverters support pulse counter which can input counting pulse through HDI terminal. When the actual length is longer than or equal to the set length, the digital output terminal can output length arrival pulse signal and the corresponding length will clear automatically.

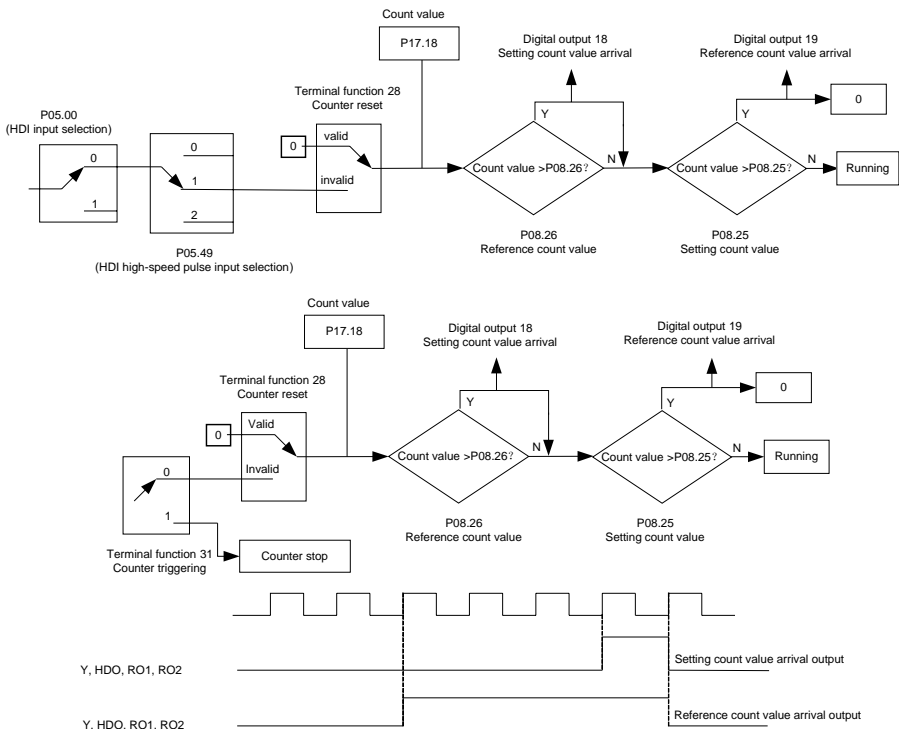

Function code	Name	Detailed instruction of parameters	Default value
P05.00	HDI input selection	0: High-speed pulse input 1: Digital input	0
P05.49	HDI high-speed pulse input selection	0: Frequency setting input 1: Counter input 2: Length counting input	0
P05.01~ P05.09	Digital input function selection	28:Counter reset 31:Counter trigger	
P06.01~ P06.04	Digital output function selection	18:Setting count value arrival 19:Reference count value arrival	
P08.25	Setting count value	P08.26~65535	0
P08.26	Reference count value	0~P08.25	0
P17.18	Count value	0~65535	0

7.18 Fixed-length control

Goodrive300-02 series inverters support fixed-length control function which can input length counting pulse through HDI, and then count the actual length according to the internal counting formula. If the actual length is longer than or equal to the set length, the digital output terminal can output the length arrival pulse signal and the corresponding length will clear automatically.

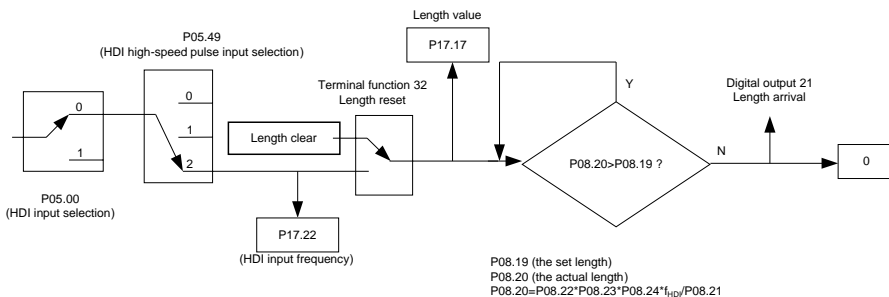

Note: The length arrival belongs to pulse output and the lasting time is 200ms.

Function code	Name	Detailed instruction of parameters	Default value
P05.00	HDI input selection	0: High-speed pulse input 1: Digital input	0
P05.49	HDI high-speed pulse input function	0:Frequency setting input 1:Counter input	0

Function code	Name	Detailed instruction of parameters	Default value
	selection	2:Length counting input	
P05.01~ P05.09	Digital input function selection	32: Length reset	
P06.01~ P06.04	Digital output function selection	21: Length arrival	
P08.19	Setting length	0~65535m	0
P08.20	Actual length	0~65535m	0
P08.21	Pulse per rotation	1~10000	1
P08.22	Axle perimeter	0.01~100.00cm	10.00
P08.23	Length ratio	0.001~10.000	1.000
P08.24	Length correcting coefficient	0.001~1.000	1.000
P17.17	Length value	0~65535	0
P17.22	HDI input frequency	Display HDI input frequency Range: 0.000~50.000kHz	0.000kHz

7.19 Fault handling

Goodrive300-02 series inverters provide sufficient fault handling information for the convenience of user's application.

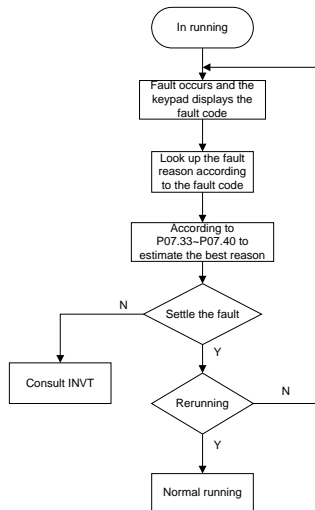

Relative parameters list:

Function code	Name	Detailed instruction of parameters	Default value
P07.27	Current fault type	0: No fault	0
P07.28	Previous fault type	1: IGBT U phase protection (OUT1)	
P07.29	Previous 2 fault type	2: IGBT V phase protection (OUT2)	
P07.30	Previous 3 fault type	3: IGBT W phase protection (OUT3)	
P07.31	Previous 4 fault type	4: ACC overcurrent (OC1)	
P07.32	Previous 5 fault type	5: DEC overcurrent (OC2)	
		6: Constant speed overcurrent (OC3)	
		7: ACC overvoltage (OV1)	
		8: DEC overvoltage (OV2)	
		9: Constant speed overvoltage (OV3)	
		10: Bus undervoltage UV	
		11: Motor overload (OL1)	
		12: Inverter overload (OL2)	
		13: Input side phase loss (SPI)	
		14: Output side phase loss (SPO)	
		15: Overheat of the rectifier module (OH1)	
		16: Overheat fault of the converter module (OH2)	
		17: External fault (EF)	
		18: 485 communication fault (CE)	
		19: Current detection fault (ItE)	
		20: Motor antotuning fault (tE)	
		21: EEPROM operation fault (EEP)	
22: PID response offline fault (PIDE)			
23: Braking unit fault (bCE)			
24: Running time arrival (END)			
25: Electrical overload (OL3)			
26: Panel communication fault (PCE)			
27: Parameter uploading fault (UPE)			
28: Parameter downloading fault (DNE)			
29: PROFIBUS communication fault (E-DP)			
30: Ethernet communication fault (E-NET)			
31: CANopen communication fault (E-CAN)			

Function code	Name	Detailed instruction of parameters	Default value
		32: Grounding short circuit fault 1 (ETH1) 33: Grounding short circuit fault 2 (ETH2) 34: Speed deviation fault (dEu) 35: Maladjustment (STo) 36: Underload fault (LL)	
P07.33	Running frequency at current fault		0.00Hz
P07.34	Ramp reference frequency at current fault		0.00Hz
P07.35	Output voltage at the current fault		0V
P07.36	Output current at current fault		0.0A
P07.37	Bus voltage at current fault		0.0V
P07.38	Max. temperature at current fault		0.0°C
P07.39	Input terminals state at current fault		0
P07.40	Output terminals state at current fault		0
P07.41	Running frequency at previous fault		0.00Hz
P07.42	Ramp reference frequency at previous fault		0.00Hz
P07.43	Output voltage at previous fault		0V
P07.44	Output current at previous fault		0.0A
P07.45	Bus voltage at previous fault		0.0V

Function code	Name	Detailed instruction of parameters	Default value
P07.46	Max. temperature at previous fault		0.0°C
P07.47	Input terminals state at previous fault		0
P07.48	Output terminals state at previous fault		0
P07.49	Running frequency at previous 2 fault		0.00Hz
P07.50	Ramp reference frequency at previous 2 fault		0.00Hz
P07.51	Output voltage at previous 2 fault		0V
P07.52	Output current at previous 2 fault		0.0A
P07.53	Bus voltage at previous 2 fault		0.0V
P07.54	Max. temperature at previous 2 fault		0.0°C
P07.55	Input terminals state at previous 2 fault		0
P07.56	Output terminals state at previous 2 fault		0

Fault tracking

8

8.1 What this chapter contains

This chapter tells how to reset faults and view fault history. It also lists all alarms and fault messages as well as the possible causes and measures.

	<p>⚡ Only qualified electricians are allowed to maintain the inverter. Read the safety instructions in <i>Safety precautions</i> before working on the inverter.</p>
---	--

8.2 Alarm and fault indications

Fault is indicated by LEDs. See *Operation procedure*. When TRIP light is on, an alarm or fault message on the keypad display indicates abnormal inverter state. Using the information given in this chapter, most alarm and fault cause can be identified and corrected. If not, contact with the INVT office.

8.3 Fault reset

The inverter can be reset by pressing the keypad key **STOP/RST**, through digital input, or by switching the power light. When the fault has been removed, the motor can be restarted.

8.4 Fault history

Function codes P07.27~P07.32 store 6 recent faults. Function codes P07.33~P07.40, P07.41~P7.48, P07.49~P07.56 show drive operation data at the time the latest 3 faults occurred.

8.5 Fault instruction and solution

Do as the following after the inverter fault:

1. Check to ensure there is nothing wrong with the keypad. If not, please contact with the local INVT office.
2. If there is nothing wrong, please check P07 and ensure the corresponding recorded fault parameters to confirm the real state when the current fault occurs by all parameters.
3. See the following table for detailed solution and check the corresponding abnormal state.
4. Eliminate the fault and ask for relative help.
5. Check to eliminate the fault and carry out fault reset to run the inverter.

8.5.1 Fault instruction and solution

Code	Fault	Cause	Solution
Out1	IGBT U phase protection	The acceleration is too fast; There is damage to the	Increase ACC time; Change the power unit;
Out2	IGBT V phase protection	internal to IGBT of the phase;	Check the driving wires; Check if there is strong

Code	Fault	Cause	Solution
OUt3	IGBT W phase protection	Interference causes faulty action; The connection of the driving wires is not good; The grounding is not good	interference to the external equipment
OV1	Accelerating overvoltage	The input voltage is abnormal; There is large energy feedback	Check the input power; Check if the DEC time of the load is too short or the inverter starts during the rotation of the motor or it needs to increase the energy consumption components
OV2	Decelerating overvoltage		
OV3	Constant overvoltage		
OC1	Accelerating overcurrent	The acceleration or deceleration is too fast;	Increase the ACC/DEC time; Check the input power; Select the inverter with a larger power; Check if the load is short circuited (the grounding short circuited or the wire short circuited) or the rotation is not smooth; Check the output configuration; Check if there is strong interference
OC2	Decelerating overcurrent	The voltage of the grid is too low;	
OC3	Constant overcurrent	The power of the inverter is too low; The load transients or is abnormal; The grounding is short circuited or the output is phase loss; There is strong external interference	
UV	Bus undervoltage fault	The voltage of the power supply is too low	Check the input power of the supply line
OL1	Motor overload	The voltage of the power supply is too low; The setting of motor rated current is incorrect; The motor stall or load transients is too strong	Check the power of the supply line; Reset the rated current of the motor Check the load and adjust the torque lift
OL2	Inverter overload	The acceleration is too fast; Reset the rotating motor;	Increase the ACC time; Avoid the restarting after

Code	Fault	Cause	Solution
		The voltage of the power supply is too low; The load is too heavy; The motor power is much larger than load power	stopping; Check the power of the supply line; Select an inverter with bigger power; Select a proper motor
SPI	Input phase loss	Phase loss or fluctuation of input R,S,T	Check input power; Check installation distribution
SPO	Output phase loss	U, V, W phase loss output (or three phases of the load are seriously asymmetrical)	Check the output distribution; Check the motor and cable
OH1	Rectifying module overheat	Air duct jam or fan damage; Ambient temperature is too high;	Dredge the air duct or change the fan; Low the ambient temperature
OH2	Converter module overheat	The time of overload running is too long	
EF	External fault	SI external fault input terminals action	Check the external device input
CE	485 communication fault	The baud rate setting is incorrect; Fault occurs to the communication wiring; The communication address is wrong; There is strong interference to the communication	Set proper baud rate; Check the communication connection distribution; Set proper communication address; Change or replace the connection distribution or improve the anti-interference capability
ItE	Current detection fault	The connection of the control board is not good; Hoare component is broken; The modifying circuit is abnormal	Check the connector and repatch; Change the Hoare; Change the main control board
tE	Motor autotuning fault	The motor capacity does not comply with the inverter	Change the inverter model; Set the rated parameter

Code	Fault	Cause	Solution
		capacity; The rated parameter of the motor does not set correctly; The offset between the parameters from autotune and the standard parameter is huge; Autotune overtime	according to the motor name plate; Empty the motor load and reidentify; Check the motor connection and set the parameter; Check if the upper limit frequency is above 2/3 of the rated frequency
EEP	EEPROM operation fault	Error of controlling the write and read of the parameters; Damage to EEPROM	Press STOP/RST to reset; Change the main control board
bCE	Braking unit fault	Braking circuit fault or damage to the braking pipes; The external braking resistor is not sufficient	Check the braking unit and change new braking pipes; Increase the braking resistor
END	Running time arrival	The actual running time of the inverter is above the internal setting running time	Ask for the supplier and adjust the setting running time
OL3	Electrical overload	The inverter will report overload pre-alarm according to the set value	Check the load and the overload pre-alarm point
PCE	Keypad communication fault	The connection of the keypad wires is not good or broken; The keypad wire is too long and affected by strong interference; There is circuit fault on the communication of the keypad and main board	Check the keypad wires and ensure whether there is mistake; Check the environment and avoid the interference source; Change the hardware and ask for service
UPE	Parameters uploading fault	The connection of the keypad wires is not good or broken;	Check the environment and eliminate interference source; Change the hardware and

Code	Fault	Cause	Solution
		The keypad wire is too long and affected by strong interference; Communication fault	ask for service; Change the hardware and ask for service;
DNE	Parameters downloading fault	The connection of the keypad wires is not good or broken; The keypad wire is too long and affected by strong interference; There is mistake on the data storage of the keypad	Check the environment and eliminate interference source; Change the hardware and ask for service; Repack up the data in the keypad
E-DP	PROFIBUS communication fault	Communication address is not correct; Corresponding resistor is not dialed; The files of main stop GSD does not set right; The ambient interference is too strong	Check the related setting; Check the environment and avoid the interference
E-NET	Ethernet communication fault	Ethernet address is not set right; Ethernet communication is not selected to right; The ambient interference is too strong	Check the related setting; Check the communication method selection; Check the environment and avoid the interference
E-CAN	CANopen communication fault	The connection is not good; Corresponding resistor is not dialed; The communication baud rate is uneven; The ambient interference is too strong	Check the connection; Draw out the corresponding resistor; Set the same baud rate; Check the environment and avoid the interference
ETH1	Grounding shortcut fault 1	The output of the inverter is short circuited with the	Check if the connection of the motor is normal or not;

Code	Fault	Cause	Solution
		ground; There is fault in the current detection circuit	Change the Hoare; Change the main control board
ETH2	Grounding shortcut fault 2	The output of the inverter is short circuited with the ground; There is fault in the current detection circuit	Check if the connection of the motor is normal or not; Change the Hoare; Change the main control board
dEu	Speed deviation fault	The load is too heavy or stalled	Check the load and ensure it is normal; Increase the detection time; Check whether the control parameters are normal
STo	Maladjustment fault	The control parameter of the synchronous motor is not set right; The autotuning parameter is not correct; The inverter is not connected to the motor	Check the load and ensure it is normal; Check whether the control parameter is set properly or not; Increase the maladjustment detection time
LL	Electronic underload fault	The inverter will report the underload pre-alarm according to the set value	Check the load and the underload pre-alarm point

8.5.2 Other faults

Code	Fault	Cause	Solution
PoFF	System power failure	The system is power-off or the bus voltage is too low	Check the environment of the power supply
	Communication failure between keypad and main control board	The keypad is not connected properly	Check the installation environment of the keypad

8.6 Common fault analysis

8.6.1 The motor does not work

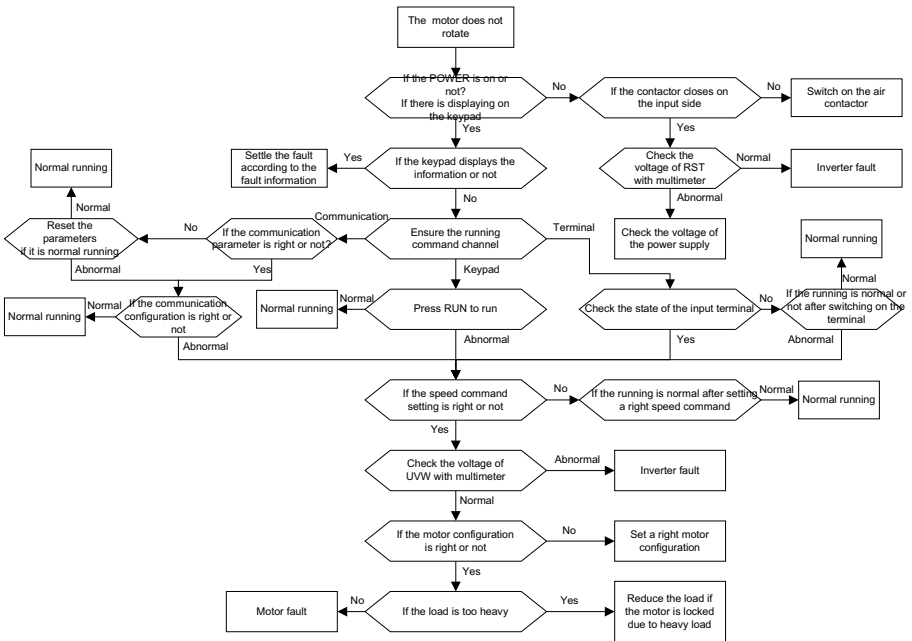

8.6.2 Motor vibration

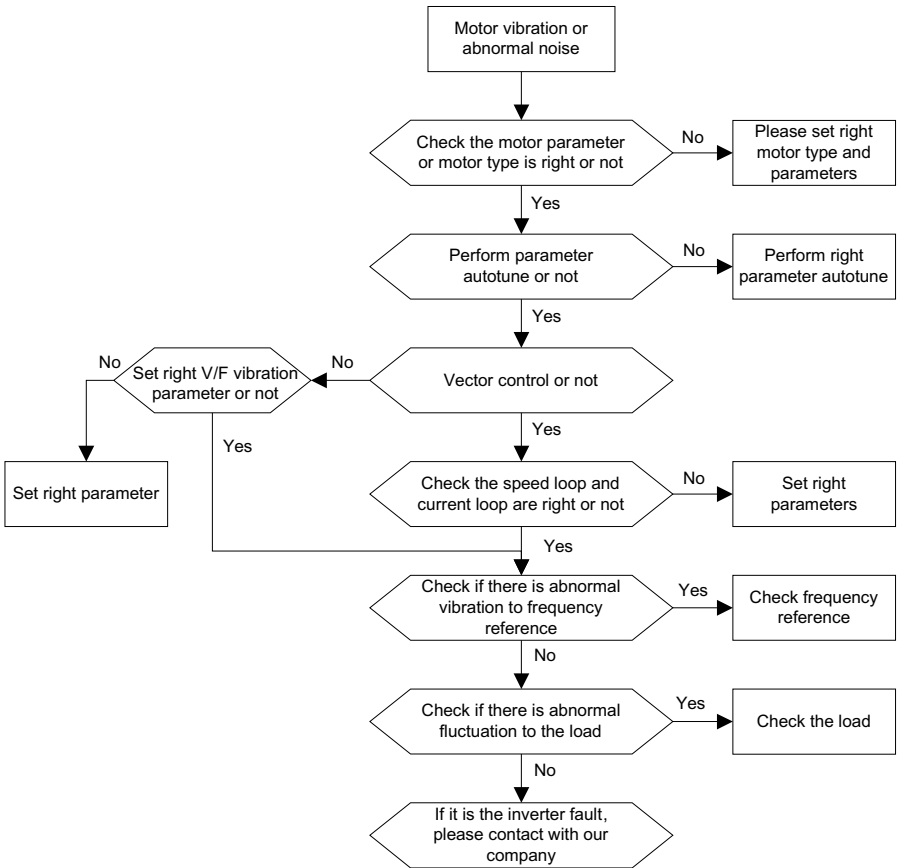

8.6.3 Overvoltage

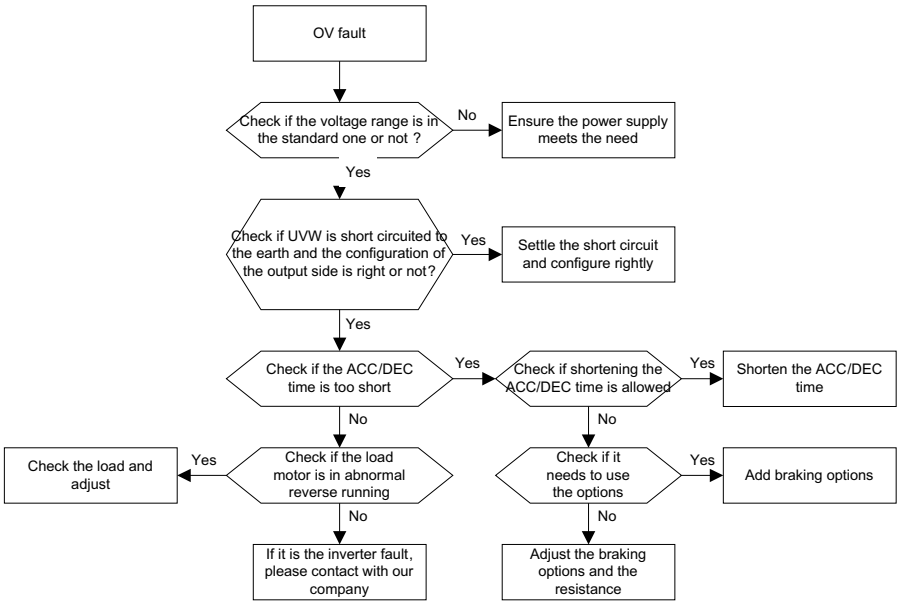

8.6.4 Undervoltage fault

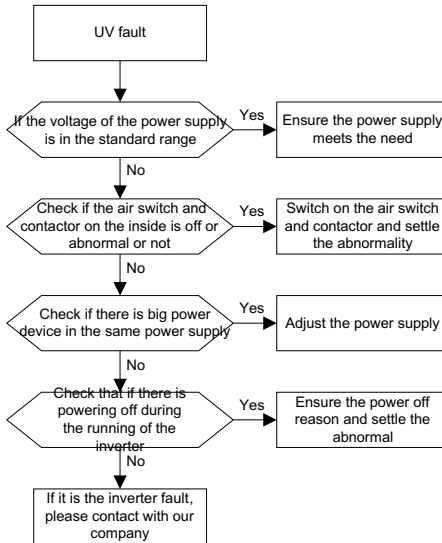

8.6.5 Abnormal heat of the motor

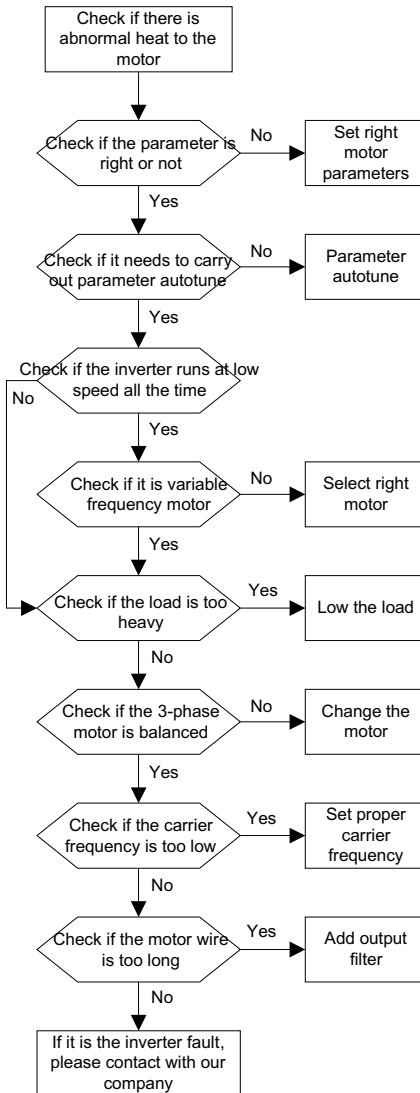

8.6.6 Overheat of the inverter

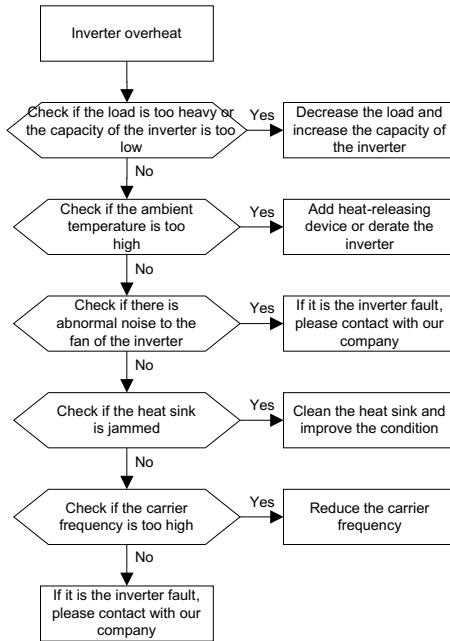

8.6.7 Motor stall during ACC

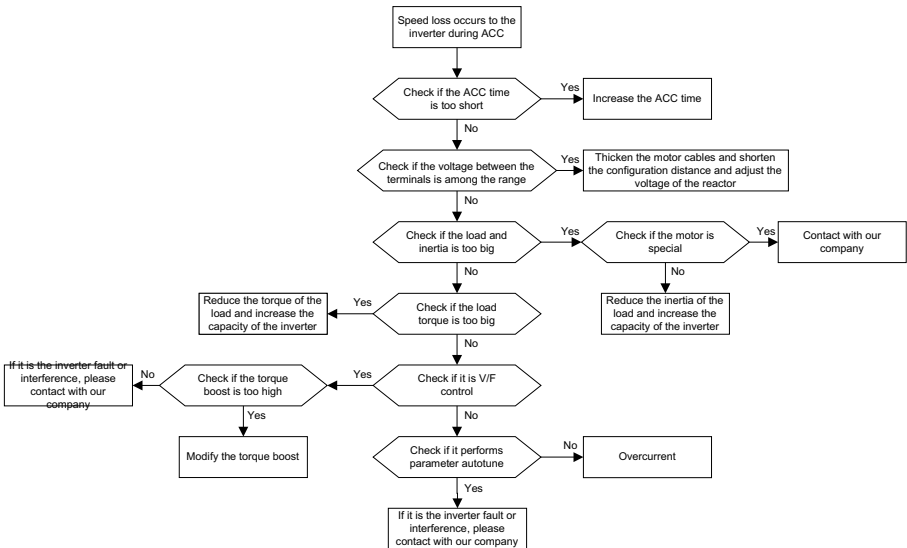

8.6.8 Overcurrent

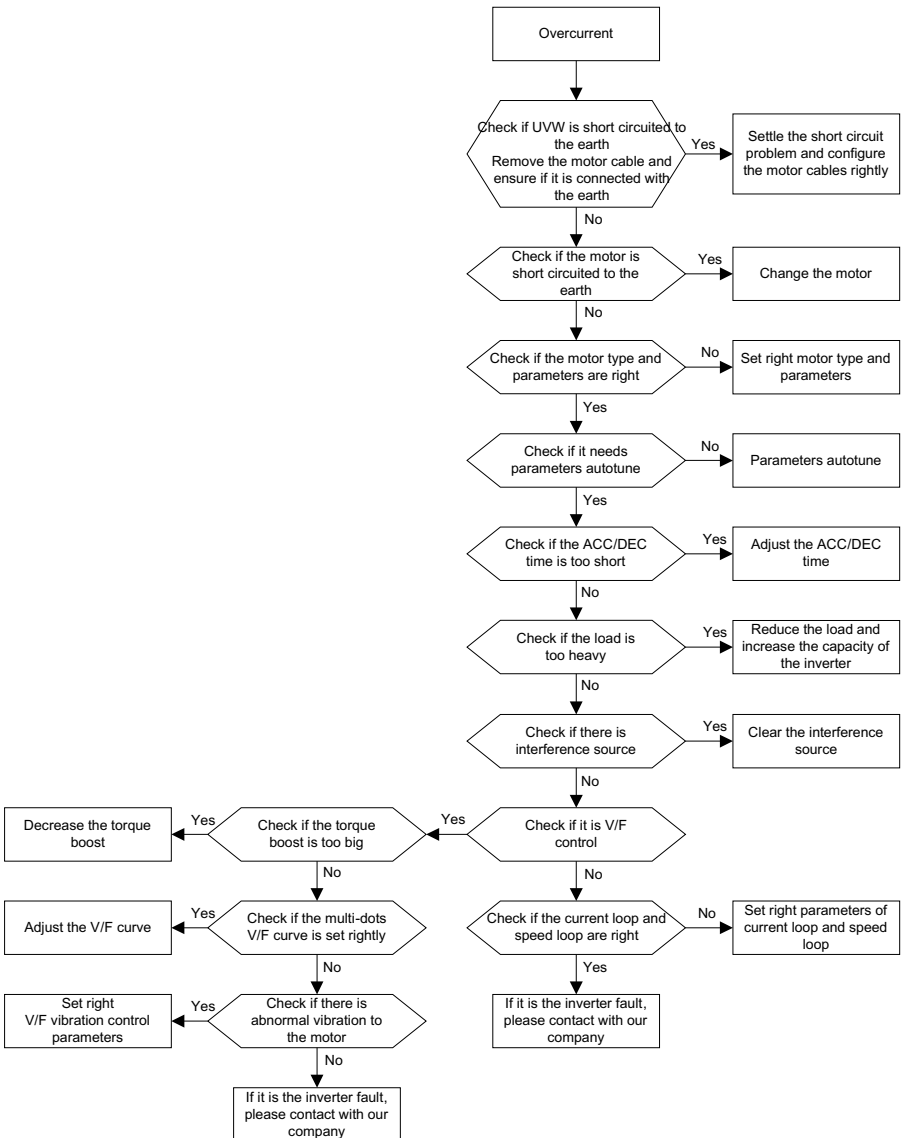

Maintenance and hardware diagnosis

9

9.1 What this chapter contains

The chapter contains preventive maintenance instructions of the inverter.

9.2 Maintenance intervals

If installed in an appropriate environment, the inverter requires very little maintenance. The table lists the routine maintenance intervals recommended by INVT.

Checking		Item	Method	Criterion
Ambient environment		Check the ambient temperature, humidity and vibration and ensure there is no dust, gas, oil fog or water drop.	Visual examination and instrument test	Conforming to the manual
		Ensure there are no tools or other foreign or dangerous objects.	Visual examination	There are no tools or dangerous objects.
Voltage		Ensure the main circuit and control circuit are normal.	Measure with multimeter	Conforming to the manual
Keypad		Ensure the display is clear enough.	Visual examination	The characters are displayed normally.
		Ensure the characters are displayed totally.	Visual examination	Conforming to the manual
Main circuit	For public use	Ensure the screws are tightened securely.	Tighten up	NA
		Ensure there is no distortion, crackles, damage or color-changing caused by overheat and aging to the machine.	Visual examination	NA
		Ensure there is no dust or dirtiness	Visual examination	NA Note: If the color of copper blocks changes, it does not mean there is something wrong

Checking	Item	Method	Criterion
			with the features.
Lead of conductors	Ensure that there is no distortion or color-changing caused by overheat to the conductors.	Visual examination	NA
	Ensure that there are no crackles or color-changing to the protective layers.	Visual examination	NA
Terminals seat	Ensure that there is no damage.	Visual examination	NA
Filter capacitors	Ensure that there is no leakage, color-changing, crackles or casing expansion.	Visual examination	NA
	Ensure the safety valve is in the right place.	Estimate the life time according to the maintenance or measure the electrostatic capacity	NA
	If necessary, measure the electrostatic capacity.	Measure the capacity by instrument	The capacity is above or equal to the original value *0.85.
Resistors	Ensure whether there is replacement and splitting caused by overheat.	Smelling and visual examination	NA
	Ensure that there is no offline.	Visual examination or remove one end to coagulate or measure with multimeter	The resistance is in $\pm 10\%$ of the standard value
Transformer and reactor	Ensure there is no abnormal vibration, noise or smelling	Hearing, smelling and visual examination	NA
Electro-	Ensure whether there is	Hearing	NA

Checking		Item	Method	Criterion
	magnetic contactor and relay	vibration noise in the workrooms.		
		Ensure the contact is in good connection.	Visual examination	NA
Control circuit	PCB and plug	Ensure there are no loose screws or contactors.	Tighten up	NA
		Ensure there is no smelling or color-changing.	Smelling and visual examination	NA
		Ensure there are no crackles, damage, distortion or rust.	Visual examination	NA
		Ensure there is no leakage or distortion to the capacitors.	Visual examination or estimate the life time according to the maintenance information	NA
Cooling system	Cooling fan	Estimate whether there is abnormal noise and vibration.	Hearing and Visual examination or rotate with hand	Stable rotation
		Estimate there is no loose screws.	Tighten up	NA
		Ensure there is no color-changing caused by overheat.	Visual examination or estimate the life time according to the maintenance information	NA
	Ventilating duct	Ensure whether there is no stuff or foreign objects in cooling fan, air inlet and air vent.	Visual examination	NA

Consult the local service representative for more details on the maintenance. Visit the official website.

9.3 Cooling fan

The inverter's cooling fan has a minimum life span of 25,000 operating hours. The actual life span depends on the inverter usage and ambient temperature.

The operating hours can be found through P07.14.

Fan failure can be predicted by the increasing noise from the fan bearings. If the inverter is operated in a critical part of a process, fan replacement is recommended once these symptoms appear. Spare fans are also available.

Replacing the cooling fan



⇨ Read and follow the instructions in chapter **Safety Precautions**. Ignoring the instructions would cause physical injury or death, or damage to the equipment.

1. Stop the inverter and disconnect it from the AC power source and wait for at least the time designated on the inverter.
2. Loosen the fan cable from the clip (remove the middle casing for the inverter of 380V 7.5~30kW).
3. Disconnect the fan cable.
4. Remove the fan with screwdriver.
5. Install the new fan in the inverter, put the fan cables in the clip and then fix the inverter well.
6. Connect the power supply.

9.4 Capacitors

9.4.1 Capacitors reforming

The DC bus capacitors must be reformed according to the operation instruction if the inverter has been stored for a long time. The storing time is counted from the delivery date.

Time	Operational principle
Storing time less than 1 year	Operation without charging
Storing time 1-2 years	Connect with the power for 1 hour before first ON command
Storing time 2-3 years	Use voltage-adjusting power supply to charge the inverter <ul style="list-style-type: none"> • charging 25% rated voltage for 30 minutes • charging 50% rated voltage for 30 minutes • charging 75% rated voltage for 30 minutes • charging 100% rated voltage for 30 minutes
Storing time more than 3 years	Use voltage-adjusting power supply to charge the inverter <ul style="list-style-type: none"> • charging 25% rated voltage for 2 hours • charging 50% rated voltage for 2 hours • charging 75% rated voltage for 2 hours • charging 100% rated voltage for 2 hours

Use voltage-adjusting power supply to charge the inverter:

The right selection of the voltage-adjusting power supply depends on the supply power of the inverter.

The single-phase 220V AC/2A voltage regulator is applied to single/three-phase 220V AC inverter.

The single/three-phase inverter can apply single-phase voltage-adjusting power supply for charging (L+ to R, N to S or T). All DC bus capacitors can charge at the same time because there is one rectifier.

High-voltage inverter needs enough voltage (for example, 380V) during charging. The small capacitor power (2A is enough) can be used because the capacitor nearly does not need current when charging.

The operation method of inverter charging through resistors (LEDs):

The charging time is at least 60 minutes if charge the DC bus capacitor directly through power supply. This operation is available on normal temperature and no-load condition and the resistor should be serially connected in the 3-phase circuits of the power supply.

380V drive device: 1K/100W resistor. LED of 100W can be used when the power voltage is no more than 380V. But if used, the light may be off or weak during charging.

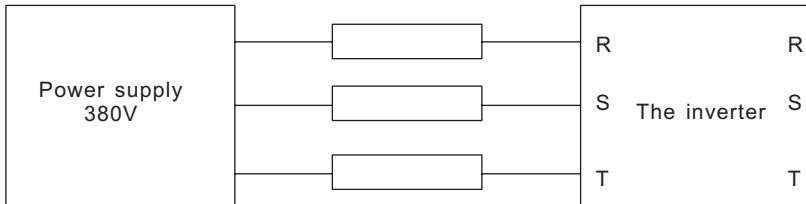

Fig 9-1 380V charging illustration of the drive device

9.4.2 Change electrolytic capacitors

	<p>⇨ Read and follow the instructions in chapter Safety Precautions. Ignoring the instructions may cause physical injury or death, or damage to the equipment.</p>
--	---

Change electrolytic capacitors if the working hours of electrolytic capacitors in the inverter are above 35,000. Please contact with the local offices or dial our national service hotline (400-700-9997) for detailed operation.

9.5 Power cable

	<p>⇨ Read and follow the instructions in chapter Safety Precautions. Ignoring the instructions may cause physical injury or death, or damage to the equipment.</p>
--	---

1. Stop the drive and disconnect it from the power line. Wait for at least the time designated on the inverter.
2. Check the tightness of the power cable connections.
3. Connect the power supply.

Communication protocol

10

10.1 What this chapter contains

This chapter describes the communication protocol of Goodrive300-02 series inverters.

Goodrive300-02 series inverters provide RS485 communication interface and adopt international standard MODBUS communication protocol to perform master-slave communication. The user can realize centralized control through PC/PLC, upper computer control, etc. (set the control command, running frequency of the inverter, modify relevant function codes, monitor and control the operating state and fault information of the inverter and so on) to adapt specific application requirements.

10.2 Brief introduction to MODBUS protocol

MODBUS protocol is a software protocol and common language which is applied in the electrical controller. With this protocol, the controller can communicate with other devices via the channel of signal transmission. And with this industrial standard, the controlling devices of different manufacturers can be connected to an industrial network for the convenience of being monitored.

There are two transmission modes for MODBUS protocol: ASCII mode and RTU (Remote Terminal Units) mode. On one MODBUS network, all devices should select the same transmission mode and their basic parameters, such as baud rate, digital bit, check bit and stop bit should have no difference. MODBUS network is a controlling network with single master and multiple slaves, which means that only one device is the master and the others are the slaves on one MODBUS network. The master can either communicate with any slave independently or send broadcasting messages to all slaves. For the independent access command, the slave will send a response message; for the broadcasting message from the master, the slave will not need to make any response message.

10.3 Application of the inverter

The MODBUS protocol of the inverter is RTU mode and the physical layer is RS485.

10.3.1 RS485

The interface of RS485 works on semiduplex and its data signal applies differential transmission which is called balance transmission, too. It uses twisted pairs, one of which is defined as A (+) and the other is defined as B (-). Generally, if the positive electrical level between sending drive A and B is among +2~+6V, it is logic "1"; if the electrical level is among -2V~-6V, it is logic "0".

485+ on the terminal board corresponds to A and 485- to B.

Communication baud rate means the binary bit number in one second. The unit is bit/s (bps). The higher the baud rate is, the quicker the transmission speed is and the weaker the anti-interference is.

If the twisted pairs of 0.56mm (24AWG) is applied as the communication cables, the Max. transmission distance is as below:

Baud rate	Max. transmission distance	Baud rate	Max. transmission distance
2400BPS	1800m	9600BPS	800m
4800BPS	1200m	19200BPS	600m

It is recommended to use shield cables and make the shield layer as the grounding wires during RS485 remote communication.

In the cases with less devices and shorter distance, it is recommended to use 120Ω terminal resistor as the performance will be weakened if the distance increase even though the network can perform well without load resistor.

10.3.1.1 Single application

Figure 1 is the site MODBUS connection figure of single inverter and PC. Generally, the computer does not have RS485 interface, the RS232 or USB interface of the computer should be converted into RS485 by converter. Connect the A terminal of RS485 to the 485+ terminal of the inverter and B to the 485- terminal. It is recommended to use the shield twisted pairs. When applying RS232-RS485 converter, if the RS232 interface of the computer is connected to the RS232 interface of the converter, the wire length should be as short as possible within the length of 15m. It is recommended to connect the RS232-RS485 converter to the computer directly. If using USB-RS485 converter, the wire should be as short as possible, too.

Select a right interface to the upper computer (select the interface of RS232-RS485 converter, such as COM1) after the wiring and set the basic parameters such as communication baud rate and digital check bit to the same as the inverter.

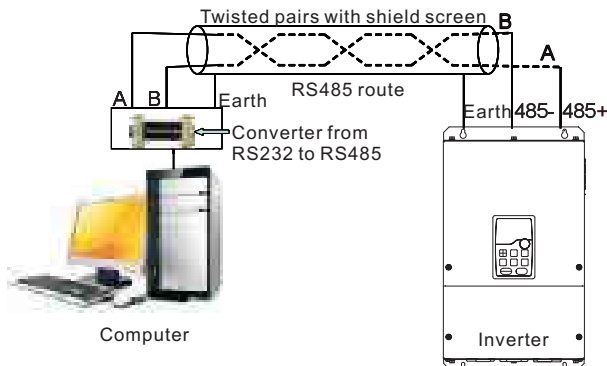

Fig 10-1 RS485 physical connection in single application

10.3.1.2 Multi-application

In the real multi-application, the chrysanthemum connection and star connection are commonly used. Chrysanthemum chain connection is required in the RS485 industrial fieldbus standards. The two ends are connected to terminal resistors of 120Ω which is shown as Figure 10-2. Figure 10-3 is the simplified connection figure and Figure 10-4 is the real application figure.

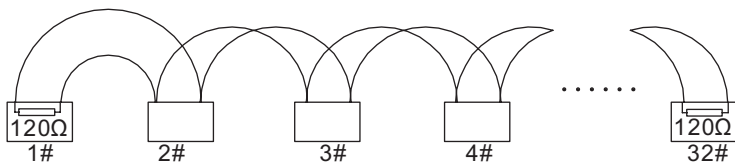

Fig 10-2 Chrysanthemum connection

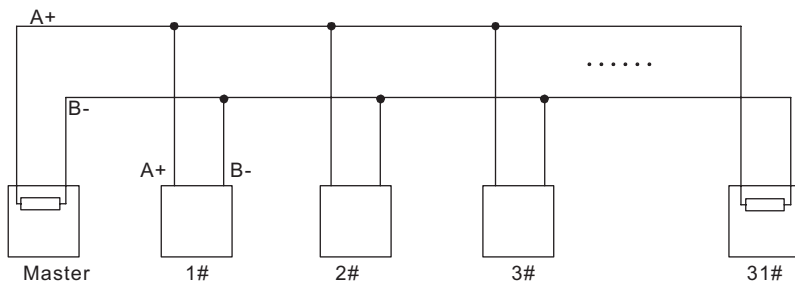

Fig 10-3 Simplified chrysanthemum connection

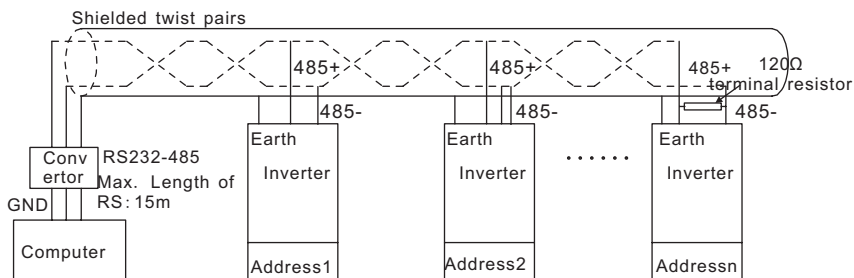

Fig 10-4 Chrysanthemum connection applications

Figure 10-5 is the star connection. Terminal resistor should be connected to the two devices which have the longest distance. (1# and 15# device)

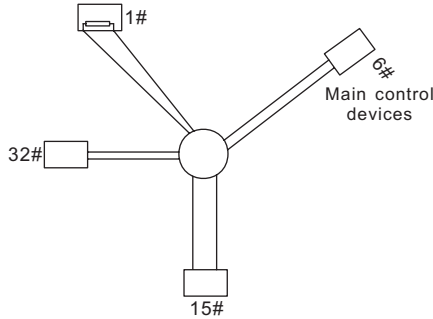

Fig 10-5 Star connection

It is recommended to use shield cables in multiple connection. The basic parameter of the devices, such as baud rate and digital check bit in RS485 should be the same and there should be no repeated address.

10.3.2 RTU mode

10.3.2.1 RTU communication frame format

If the controller is set to communicate by RTU mode in MODBUS network every 8bit byte in the message includes two 4Bit hex characters. Compared with ACSII mode, this mode can send more data at the same baud rate.

Code system

- 1 start bit
- 7 or 8 digital bit, the minimum valid bit can be sent firstly. Every 8 bit frame includes two hex characters (0...9, A...F)
- 1 even/odd check bit . If there is no checkout, the even/odd check bit is inexistent.
- 1 end bit (with checkout), 2 Bit (no checkout)

Error detection field

- CRC

The data format is illustrated as below:

11-bit character frame (BIT1~BIT8 are the data bits)

Start bit	BIT1	BIT2	BIT3	BIT4	BIT5	BIT6	BIT7	BIT8	Check bit	End bit
-----------	------	------	------	------	------	------	------	------	-----------	---------

10-bit character frame (BIT1~BIT7 are the data bits)

Start bit	BIT1	BIT2	BIT3	BIT4	BIT5	BIT6	BIT7	Check bit	End bit
-----------	------	------	------	------	------	------	------	-----------	---------

In one character frame, the digital bit takes effect. The start bit, check bit and end bit is used to send the digital bit right to the other device. The digital bit, even/odd checkout and end bit should be set as

the same in real application.

In the RTU mode, the minimum idle time between new frames should be no less than 3.5 bytes. In the network whose transmission speed is calculated by baud rate, transmission time of 3.5 bytes can be controlled easily. The data fields are as follows: slave address, operation code, data and CRC checkout, the byte of each field is hex (0..9, A..F). The network device is always monitoring the action of communication bus. When the first field (the address message) is received, each device will confirm the byte. After the final byte is transmitted, there will be another interval time similar to 3.5 bytes to indicate the end of the frame. Later, a new frame will start.

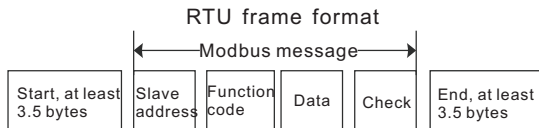

The whole message frame in RTU mode is a continuous transmitting flow. If there is an interval time (more than 1.5 bytes) before the completion of the frame, the receiving device will renew the uncompleted message and suppose the next byte as the address field of the new message. As such, if the new message follows the previous one within the interval time of 3.5 bytes, the receiving device will deal with it as the same with the previous message. If these two phenomena all happen during the transmission, the CRC will generate a fault message to respond to the sending devices.

The standard structure of RTU frame:

START	T1-T2-T3-T4 (transmission time of 3.5 bytes)
ADDR	Communication address: 0~247 (decimal system) (0 is the broadcast address)
CMD	03H: read slave parameters 06H: write slave parameters
DATA (N-1) ... DATA (0)	The data of 2*N bytes are the main content of the communication as well as the core of data exchanging
CRC CHK low bit	Detection value: CRC (16BIT)
CRC CHK high bit	
END	T1-T2-T3-T4 (transmission time of 3.5 bytes)

10.3.2.2 RTU communication frame error checkout

Various factors may cause errors in the data transmission. If there is no error checkout, the receiving devices will not find the message is wrong and they may give an incorrect response which may cause serious impact. So the checkout is essential to the message.

The theme of checkout is that: the sender calculates the sending data according to a fixed formula, and then sends the result with the message. When the receiver gets this message, it will calculate another result according to the same method and compare it with the sending one. If two results are the same, the message is correct. If not, the message is incorrect.

The error checkout of the frame can be divided into two parts: the bit checkout of the byte and the whole data checkout of the frame (CRC check).

Bit checkout of the byte

The user can select different bit checkouts or non-checkout, which impacts the check bit setting of each byte.

The definition of even checkout: add an even check bit before the data transmission to illustrate the number of "1" in the data transmission is odd number or even number. When it is even, the check byte is "0", otherwise, the check byte is "1". This method is used to stabilize the parity of the data.

The definition of odd checkout: add an odd check bit before the data transmission to illustrate the number of "1" in the data transmission is odd number or even number. When it is odd, the check byte is "0", otherwise, the check byte is "1". This method is used to stabilize the parity of the data.

For example, when transmitting "11001110", there are five "1" in the data. If the even checkout is applied, the even check bit is "1"; if the odd checkout is applied; the odd check bit is "0". The even and odd check bit is calculated on the check bit position of the frame. And the receiving devices also carry out even and odd checkout. If the parity of the receiving data is different from the setting value, there is an error in the communication.

CRC check (Cyclical Redundancy Check)

The checkout uses RTU frame format. The frame includes the frame error detection field which is based on the CRC calculation method. The CRC field is two bytes, including 16 figure binary values. It is added into the frame after calculated by transmitting device. The receiving device recalculates the CRC of the received frame and compares them with the value in the received CRC field. If the two CRC values are different, there is an error in the communication.

During CRC, 0xFFFF will be stored. And then, deal with the continuous 6-above bytes in the frame and the value in the register. Only the 8Bit data in every character is effective to CRC, while the start bit, the end and the odd and even check bit is ineffective.

Each 8 bit character xors with the register, the result moves to the lowest effective bit and the highest bit is filled by 0. If LSB is detected to be 1, the register will xor with the preset value. If LSB is 0, the action will not carry on. Repeat 8 times during the whole process. After the last bit is completed, the next 8 bit character will xor with the current value of the register. The final value in the register is the

CRC after the completion of operating all bytes.

The calculation of CRC applies the international standard CRC checkout principles. When the user is editing CRC calculation, he can refer to the relative standard CRC calculation to write the required CRC calculation program.

Here provided a simple function of CRC calculation for the reference (programmed with C language):

```

unsigned int crc_cal_value(unsigned char*data_value,unsigned char data_length)
{
    int i;
    unsigned int crc_value=0xffff;
    while(data_length--)
    {
        crc_value^=*data_value++;
        for(i=0;i<8;i++)
        {
            if(crc_value&0x0001)
                crc_value=(crc_value>>1)^0xa001;
            else
                crc_value=crc_value>>1;
        }
    }
    return(crc_value);
}

```

In ladder logic, CKSM calculated the CRC value according to the frame with the table inquiry. The method is advanced with easy program and quick calculation speed. But the ROM space the program occupied is huge. So use it with caution according to the program required space.

10.4 RTU command code and communication data illustration

10.4.1 Command code: 03H, read N words (Max. continuous reading is 16 words)

Command code 03H means that if the master read data for the inverter, the reading number depends on the "data number" in the command code. The Max. continuous reading number is 16 and the parameter address should be continuous. The byte length of every data is 2 (one word). The following command format is illustrated by hex (a number with "H" means hex) and one hex occupies one byte. The command code is used to read the working stage of the inverter.

For example, read continuous 2 data content from 0004H from the inverter with the address of 01H

(read the content of data address of 0004H and 0005H), the frame structure is as below:

RTU master command message (from the master to the inverter)

START	T1-T2-T3-T4 (transmission time of 3.5 bytes)
ADDR	01H
CMD	03H
High bit of the start bit	00H
Low bit of the start bit	04H
High bit of data number	00H
Low bit of data number	02H
CRC low bit	85H
CRC high bit	CAH
END	T1-T2-T3-T4 (transmission time of 3.5 bytes)

T1-T2-T3-T4 between START and END is to provide at least the time of 3.5 bytes as the leisure time and distinguish two messages for the avoidance of taking two messages as one message.

ADDR=01H means the command message is sent to the inverter with the address of 01H and ADDR occupies one byte;

CMD=03H means the command message is sent to read data from the inverter and CMD occupies one byte;

“Start address” means reading data from the address and it occupies 2 bytes with the fact that the high bit is in the front and the low bit is in the behind.

“Data number” means the reading data number with the unit of word. If the “start address” is 0004H and the “data number” is 0002H, the data of 0004H and 0005H will be read.

CRC occupies 2 bytes with the fact that the low bit is in the front and the high bit is in the behind.

RTU slave response message (from the inverter to the master)

START	T1-T2-T3-T4 (transmission time of 3.5 bytes)
ADDR	01H
CMD	03H
Byte number	04H
Data high bit of address 0004H	13H
Data low bit of address 0004H	88H
Data high bit of address 0005H	00H
Data low bit of address 0005H	00H

CRC low bit	7EH
CRC high bit	9DH
END	T1-T2-T3-T4 (transmission time of 3.5 bytes)

The meaning of the response is that:

ADDR=01H means the command message is sent to the inverter with the address of 01H and ADDR occupies one byte;

CMD=03H means the message is received from the inverter to the master for the response of reading command and CMD occupies one byte;

"Byte number" means all byte number from the byte (excluding the byte) to CRC byte (excluding the byte). 04 means there are 4 byte of data from the "byte number" to "CRC low bit", which are "digital address 0004H high bit", "data low bit of address 0004H", "data high bit of address 0005H" and "data low bit of address 0005H".

There are 2 bytes stored in one data with the fact that the high bit is in the front and the low bit is in the behind of the message, the data of address 0004H is 1388H, and the data of address 0005H is 0000H.

CRC occupies 2 bytes with the fact that the low bit is in the front and the high bit is in the behind.

10.4.2 Command code: 06H, write one word

The command means that the master write data to the inverter and one command can write one data other than multiple data. The effect is to change the working mode of the inverter.

For example, write 5000 (1388H) to 0004H from the inverter with the address of 02H, the frame structure is as below:

RTU master command message (from the master to the inverter)

START	T1-T2-T3-T4 (transmission time of 3.5 bytes)
ADDR	02H
CMD	06H
High bit of writing data address	00H
Low bit of writing data address	04H
High bit of data content	13H
Low bit of data content	88H
CRC low bit	C5H
CRC high bit	6EH
END	T1-T2-T3-T4 (transmission time of 3.5 bytes)

RTU slave response message (from the inverter to the master)

START	T1-T2-T3-T4 (transmission time of 3.5 bytes)
ADDR	02H
CMD	06H
High bit of writing data address	00H
Low bit of writing data address	04H
High bit of data content	13H
Low bit of data content	88H
CRC low bit	C5H
CRC high bit	6EH
END	T1-T2-T3-T4 (transmission time of 3.5 bytes)

Note: 10.4.8 mainly describe the command format, and the detailed application will be mentioned in 10.4.8 with examples.

10.4.3 Command code: 08H, diagnosis function

Meaning of sub-function codes:

Sub-function code	Description
0000	Return to inquire information data

For example: The inquiry information string is same as the response information string when the loop detection to address 01H of driver is carried out.

The RTU request command is:

START	T1-T2-T3-T4 (transmission time of 3.5 bytes)
ADDR	01H
CMD	08H
High bit of sub-function code	00H
Low bit of sub-function code	00H
High bit of data content	12H
Low bit of data content	ABH
CRC CHK low bit	ADH
CRC CHK high bit	14H
END	T1-T2-T3-T4 (transmission time of 3.5 bytes)

The RTU response command is:

START	T1-T2-T3-T4 (transmission time of 3.5 bytes)
-------	--

ADDR	01H
CMD	08H
High bit of sub-function code	00H
Low bit of sub-function code	00H
High bit of data content	12H
Low bit of data content	ABH
CRC CHK low bit	ADH
CRC CHK high bit	14H
END	T1-T2-T3-T4 (transmission time of 3.5 bytes)

10.4.4 Command code: 10H, continuous writing

Command code 10H means that if the master writes data to the inverter, the data number depends on the "data number" in the command code. The Max. continuous reading number is 16.

For example, write 5000(1388H) to 0004H of the inverter whose slave address is 02H and 50(0032H) to 0005H, the frame structure is as below:

The RTU request command is:

START	T1-T2-T3-T4 (transmission time of 3.5 bytes)
ADDR	02H
CMD	10H
High bit of write data	00H
Low bit of write data	04H
High bit of data number	00H
Low bit of data number	02H
Byte number	04H
High bit of data 0004H	13H
Low bit of data 0004H	88H
High bit of data 0005H	00H
Low bit of data 0005H	32H
Low bit of CRC	C5H
High bit of CRC	6EH
END	T1-T2-T3-T4 (transmission time of 3.5 bytes)

The RTU response command is:

START	T1-T2-T3-T4 (transmission time of 3.5 bytes)
ADDR	02H
CMD	10H

High bit of write data	00H
Low bit of write data	04H
High bit of data number	00H
Low bit of data number	02H
Low bit of CRC	C5H
High bit of CRC	6EH
END	T1-T2-T3-T4 (transmission time of 3.5 bytes)

10.4.5 The definition of data address

The address definition of the communication data in this part is to control the running of the inverter and get the state information and relative function parameters of the inverter.

10.4.5.1 The rules of parameter address of the function codes

The parameter address occupies 2 bytes with the fact that the high bit is in the front and the low bit is in the behind. The range of high and low byte are: high byte-00~ffH; low byte-00~ffH. The high byte is the group number before the radix point of the function code and the low byte is the number after the radix point. But both the high byte and the low byte should be changed into hex. For example P05.06, the group number before the radix point of the function code is 05, then the high bit of the parameter is 05, the number after the radix point 06, then the low bit of the parameter is 06, then the function code address is 0506H and the parameter address of P10.01 is 0A01H.

Function code	Name	Detailed instruction of parameters	Setting range	Default value	Modify	Serial No.
P10.00	Simple PLC	0: Stop after running once 1: Run at the final value after running o 2: Cycle running	0~2	0	<input type="radio"/>	354.
P10.01	Simple PLC memory	0: Power loss without memory 1: Power loss memory	0~1	0	<input type="radio"/>	355.

Note: P29 group is the factory parameter which cannot be read or changed. Some parameters cannot be changed when the inverter is in the running state and some parameters cannot be changed in any state. The setting range, unit and relative instructions should be paid attention to when modifying the function code parameters.

Besides, EEPROM is stocked frequently, which may shorten the usage time of EEPROM. For users, some functions are not necessary to be stocked on the communication mode. The needs can be met on by changing the value in RAM. Changing the high bit of the function code from 0 to 1 can also realize the function. For example, the function code P00.07 is not stocked into EEPROM. Only by changing the value in RAM can set the address to 8007H. This address can only be used in writing RAM other than reading. If it is used to read, it is an invalid address.

10.4.5.2 The address instruction of other function in MODBUS

The master can operate the parameters of the inverter as well as control the inverter, such as running or stopping and monitoring the working state of the inverter.

Below is the parameter list of other functions:

Function instruction	Address definition	Data meaning instruction	R/W characteristics
Communication control command	2000H	0001H:forward running	W/R
		0002H:reverse running	
		0003H:forward jogging	
		0004H:reverse jogging	
		0005H:stop	
		0006H:coast to stop (emergency stop)	
		0007H:fault reset	
		0008H:jogging stop	
The address of communication setting	2001H	Communication setting frequency (0~Fmax(unit: 0.01Hz))	W/R
	2002H	PID reference, range (0~1000, 1000 corresponds to 100.0%)	
	2003H	PID feedback, range (0~1000, 1000 corresponds to 100.0%)	W/R
	2004H	Torque setting value (-3000~3000, 1000 corresponds to the 100.0% of the rated current of the motor)	W/R
	2005H	The upper limit frequency setting during forward rotation (0~Fmax(unit: 0.01Hz))	W/R
	2006H	The upper limit frequency setting during reverse rotation (0~Fmax(unit: 0.01Hz))	W/R
	2007H	The upper limit torque of electromotion torque (0~3000, 1000 corresponds to the 100.0% of the rated current of the motor)	W/R
	2008H	The upper limit torque of braking torque (0~3000, 1000 corresponds to the 100.0% of the rated current of the motor)	W/R
	2009H	Special control command word Bit0~1:=00: motor 1 =01: motor 2 =10: motor 3 =11: motor 4 Bit2:=1 torque control prohibit	W/R

Function instruction	Address definition	Data meaning instruction	R/W characteristics
		=0: torque control Bit3:=1 power consumption clear =0: no power consumption clear Bit4:=1 pre-exciting enabling =0: pre-exciting disabling Bit5:=1 DC braking enabling =0: DC braking disabling	
	200AH	Virtual input terminal command , range: 0x000~0x1FF	W/R
	200BH	Virtual output terminal command , range: 0x00~0x0F	W/R
	200CH	Voltage setting value (special for V/F separation) (0~1000, 1000 corresponds to the 100.0%)	W/R
	200DH	AO output setting 1 (-1000~1000, 1000 corresponds to 100.0%)	W/R
	200EH	AO output setting 2 (-1000~1000, 1000 corresponds to 100.0%)	W/R
SW 1 of the inverter	2100H	0001H:forward running	R
		0002H:forward running	
		0003H:stop	
		0004H:fault	
		0005H: POFF state	
		0006H: pre-exciting state	
SW 2 of the inverter	2101H	Bit0: =0: ready for operation =1: not ready for operation Bit1~2: =00:motor 1 =01:motor 2 =10:motor 3 =11:motor 4 Bit3: =0:asynchronous motor =1:synchronous motor Bit4: =0:pre-alarm without overload =1:overload pre-alarm Bit5~ Bit6: =00: keypad control =01: terminal control =10: communication control	R

Function instruction	Address definition	Data meaning instruction	R/W characteristics
Fault code of the inverter	2102H	See the fault type instruction	R
Identifying code of the inverter	2103H	GD300---0x010a	R
Operation frequency	3000H	0~Fmax (unit: 0.01Hz)	R
Setting frequency	3001H	0~Fmax (unit: 0.01Hz)	R
Bus voltage	3002H	0.0~2000.0V (unit: 0.1V)	R
Output voltage	3003H	0~1200V (unit: 1V)	R
Output current	3004H	0.0~3000.0A (unit: 0.1A)	R
Rotation speed	3005H	0~65535 (unit: 1RPM)	R
Output power	3006H	-300.0~300.0% (unit: 0.1%)	R
Output torque	3007H	-250.0~250.0% (unit: 0.1%)	R
Close loop setting	3008H	-100.0~100.0% (unit: 0.1%)	R
Close loop feedback	3009H	-100.0~100.0% (unit: 0.1%)	R
Input IO state	300AH	000~1FF	R
Output IO state	300BH	000~1FF	R
Analog input 1	300CH	0.00~10.00V (unit: 0.01V)	R
Analog input 2	300DH	0.00~10.00V (unit: 0.01V)	R
Analog input 3	300EH	0.00~10.00V (unit: 0.01V)	R
Analog input 4	300FH		R
Read input of high-speed pulse 1	3010H	0.00~50.00kHz (unit: 0.01Hz)	R
Read input of high-speed pulse 2	3011H		R
Read the current step of multi-step speed	3012H	0~15	R
External length	3013H	0~65535	R
External counting	3014H	0~65535	R
Torque setting	3015H	-300.0~300.0% (unit: 0.1%)	R
Identifying code of the inverter	3016H		R
Fault code	5000H		R

R/W characteristics means the function is with read and write characteristics. For example, "communication control command" is writing characteristics and control the inverter with writing

command (06H). R characteristic can only read other than write and W characteristic can only write other than read.

Note: When operate the inverter with the table above, it is necessary to enable some parameters. For example, the operation of running and stopping, it is necessary to set P00.01 to communication running command channel and set P00.02 to MODBUS communication channel. And when operate "PID reference", it is necessary to set P09.00 to "MODBUS communication setting".

The encoding rules for device codes (corresponds to identifying code 2103H of the inverter)

High 8 bit	Meaning	Low 8 bit	Meaning
01	GD	0x08	GD35 vector inverter
		0x0a	GD300 vector inverter

10.4.6 Fieldbus ratio values

The communication data is expressed by hex in actual application and there is no radix point in hex. For example, 50.12Hz cannot be expressed by hex so 50.12 can be magnified by 100 times into 5012, so hex 1394H can be used to express 50.12.

A non-integer can be timed by a multiple to get an integer and the integer can be called fieldbus ratio values.

The fieldbus ratio values are referred to the radix point of the setting range or default value in the function parameter list. If there are figures behind the radix point (n=1), then the fieldbus ratio value m is 10ⁿ. Take the table as the example:

Function code	Name	Detailed instruction of parameters	Setting range	Default value	Modify	Serial No.
P01.20	Hibernation restore delay time	0.0~3600.0s (valid when P01.19=2)	0.0~3600.0	0.0s	<input type="radio"/>	39.
P01.21	Restart after power off	0: Disable 1: Enable	0~1	0	<input type="radio"/>	40.

If there is one figure behind the radix point in the setting range or the default value, then the fieldbus ratio value is 10. If the data received by the upper computer is 50, then the "hibernation restore delay time" is 5.0 (5.0=50÷10).

If MODBUS communication is used to control the hibernation restore delay time as 5.0s. Firstly, 5.0 can be magnified by 10 times to integer 50 (32H) and then this data can be sent.

01 06 01 14 00 32 49 E7
 Inverter Write Parameters Data number CRC check
 address command address

After the inverter receives the command, it will change 50 into 5.0 according to the fieldbus ratio value

and then set the hibernation restore delay time as 5.0s.

Another example, after the upper computer sends the command of reading the parameter of hibernation restore delay time, the response message of the inverter is as follows:

<u>01</u>	<u>03</u>	<u>02</u>	<u>00 32</u>	<u>39 91</u>
Inverter address	Read command	2-byte data	Parameters data	CRC check

Because the parameter data is 0032H (50) and 50 divided by 10 is 5.0, then the hibernation restore delay time is 5.0s.

10.4.7 Fault message response

There may be fault in the communication control. For example, some parameter can only be read. If a writing message is sent, the inverter will return a fault response message.

The fault message is from the inverter to the master, its code and meaning is as below:

Code	Name	Meaning
01H	Illegal command	The command from master cannot be executed. The reason may be: 1. This command is only for new device; 2. Slave is in fault state and cannot execute it.
02H	Illegal data address	Some of the operation addresses are invalid or not allowed to access. Especially the combination of the register and the transmitting bytes are invalid.
03H	Illegal value	When there are invalid data in the message framed received by slave. Note: This error code does not indicate the data value to write exceed the range, but indicate the message frame is an illegal frame.
04H	Operation failed	The parameter setting in parameter writing is invalid. For example, the function input terminal cannot be set repeatedly.
05H	Password error	The password written to the password check address is not same as the password set by P7.00.
06H	Data frame error	In the frame message sent by the upper computer, the length of the digital frame is incorrect or the counting of CRC check bit in RTU is different from the lower computer.
07H	Parameters only for read	It only happens in write command

Code	Name	Meaning
08H	Parameters cannot be changed during running	The modified parameter in the writing of the upper computer cannot be modified during running.
09H	Password protection	When the upper computer is writing or reading and the user password is set without password unlocking, it will report that the system is locked.

The slave uses functional code fields and fault addresses to indicate it is a normal response or some error occurs (named as objection response). For normal responses, the slave shows corresponding function codes, digital address or sub-function codes as the response. For objection responses, the slave returns a code which equals the normal code, but the first byte is logic 1.

For example: when the master sends a message to the slave, requiring it to read a group of address data of the inverter function codes, there will be following function codes:

0 0 0 0 0 0 1 1 (Hex 03H)

For normal responses, the slave responds the same codes, while for objection responses, it will return:

1 0 0 0 0 0 1 1 (Hex 83H)

Besides the function codes modification for the objection fault, the slave will respond a byte of abnormal code which defines the error reason. When the master receives the response for the objection, in a typical processing, it will send the message again or modify the corresponding order.

For example, set the "running command channel" of the inverter (P00.01, parameter address is 0001H) with the address of 01H to 03, the command is as following:

01 **06** **00 01** **00 03** **98 0B**
 Inverter Write Parameters Parameters CRC check
 address command address data

But the setting range of "running command channel" is 0~2, if it is set to 3, because the number is beyond the range, the inverter will return fault response message as below:

01 **86** **04** **43 A3**
 Inverter Abnormal Fault code CRC check
 address response code
 code

Abnormal response code 86H means the abnormal response to writing command 06H; the fault code is 04H. In the table above, its name is operation failed and its meaning is that the parameter setting in parameter writing is invalid.

10.4.8 Example of writing and reading

Refer to 10.4.1 and 10.4.2 for the command format.

10.4.8.1 Example of reading command 03H

Example 1: Read the state word 1 of the inverter with the address of 01H (refer to table 1). From the table 1, the parameter address of the state word 1 of the inverter is 2100H.

The command sent to the inverter:

<u>01</u>	<u>03</u>	<u>21 00</u>	<u>00 01</u>	<u>8E 36</u>
Inverter address	Read command	Parameters address	Data number	CRC check

If the response message is as below:

<u>01</u>	<u>03</u>	<u>02</u>	<u>00 03</u>	<u>F8 45</u>
Inverter address	Read command	Parameters address	Data number	CRC check

The data content is 0003H. From the table 1, the inverter stops.

Example 2: Watch “the current fault type” to “the previous 5 times fault type” of the inverter through commands, the corresponding function code is P07.27~P07.32 and corresponding parameter address is 071BH~0720H (there are 6 from 071BH).

The command sent to the inverter:

<u>03</u>	<u>03</u>	<u>07 1B</u>	<u>00 06</u>	<u>B5 59</u>
Inverter address	Read command	Starting address	6 parameters	CRC check

If the response message is as below:

<u>03</u>	<u>03</u>	<u>0C 00</u>	<u>23 00</u>	<u>23 00</u>	<u>23 00</u>	<u>23 00</u>	<u>23 00</u>	<u>23 00</u>	<u>23 00</u>	<u>23 00</u>	<u>23 5F</u>	<u>D2</u>
Inverter address	Read command	Byte number	Current fault type	Previous fault type	Previous 2 fault type	Previous 3 fault type	Previous 4 fault type	Previous 5 fault type	Previous 6 fault type	Previous 7 fault type	Previous 8 fault type	CRC check

See from the returned data, all fault types are 0023H (decimal 35) with the meaning of maladjustment (STo).

10.4.8.2 Example of writing command 06H

Example 1: Make the inverter with the address of 03H to run forward. See table 1, the address of “communication control command” is 2000H and forward running is 0001. See the table below.

Function instruction	Address definition	Data meaning instruction	R/W characteristics
Communication control command	2000H	0001H:forward running	W
		0002H:reverse running	
		0003H:forward jogging	
		0004H:reverse jogging	
		0005H:stop	
		0006H:coast to stop (emergency stop)	
		0007H:fault reset	
		0008H:jogging stop	
		0009H:pre-exciting	

The command sent by the master:

03 06 20 00 00 01 42 28
 Inverter address Write command Parameters address Forward running CRC check

If the operation is successful, the response may be as below (the same with the command sent by the master):

03 06 20 00 00 01 42 28
 Inverter address Write command Parameters address Forward running CRC check

Example 2: Set the Max. output frequency of the inverter with the address of 03H as 100Hz.

Function code	Name	Detailed instruction of parameters	Setting range	Default value	Modify	Serial No.
P00.03	Max. output frequency	P00.04~600.00Hz (400.00Hz)	10.00~600.00	50.00Hz	⊙	3.

See the figures behind the radix point, the fieldbus ratio value of the Max. output frequency (P00.03) is 100. 100Hz timed by 100 is 10000 and the corresponding hex is 2710H.

The command sent by the master:

03 06 00 03 27 10 62 14
 Inverter address Write command Parameters address Parameters data CRC check

If the operation is success, the response may be as below (the same with the command sent by the master):

03 06 00 03 27 10 62 14
 Inverter address Write command Parameters address Parameters data CRC check

Note: The blank in the above command is for illustration and it cannot be added in the actual

application.

10.4.8.3 Example of continuous writing command 10H

Example 1: make the inverter whose address is 01H run forward at 10Hz. Refer to the instruction of 2000H and 0001. Set the address of “communication setting frequency” is 2001H and 10Hz corresponds to 03E8H. See the table below.

Function instruction	Address definition	Data meaning instruction	R/W characteristics
Communication control command	2000H	0001H:forward running	W/R
		0002H:reverse running	
		0003H:forward jogging	
		0004H:reverse jogging	
		0005H:stop	
		0006H:coast to stop (emergency stop)	
		0007H:fault reset	
		0008H:jogging stop	
The address of communication setting	2001H	Communication setting frequency (0~Fmax(unit: 0.01Hz))	W/R
	2002H	PID reference, range (0~1000, 1000 corresponds to 100.0%)	

Set P00.01 to 2 and P00.06 to 8.

The command sent to the inverter:

01 **10** **20 00** **00 02** **04** **00 01 03 E8** **3B 10**
 Inverter address Continuous writing command Parameters address Data number Byte number Forward running 10Hz CRC check

If the response message is as below:

01 **10** **20 00** **00 02** **4A 08**
 Inverter address Continuous writing command Parameters address Data number CRC check

Example 2: set the ACC time of 01H inverter as 10s and the DEC time as 20s

P00.11	ACC time 1	Setting range of P00.11 and P00.12: 0.0~3600.0s	Depend on model	<input type="radio"/>
P00.12	DEC time 1		Depend on model	<input type="radio"/>

The corresponding address of P00.11 is 000B, the ACC time of 10s corresponds to 0064H, and the DEC time of 20s corresponds to 00C8H.

The command sent to the inverter:

<u>01</u>	<u>10</u>	<u>00 0B</u>	<u>00 02</u>	<u>04</u>	<u>00 64</u>	<u>00 C8</u>	<u>F2 55</u>
Inverter address	Continuous writing command	Parameters address	Data number	Byte number	10s	20s	CRC check

If the response message is as below:

<u>01</u>	<u>10</u>	<u>00 0B</u>	<u>00 02</u>	<u>30 0A</u>
Inverter address	Continuous writing command	Parameters address	Data number	CRC check

Note: The space between above commands is for instruction and there is no space between the commands during actual applications.

10.5 Common communication fault

Common communication faults: no response to the communication or the inverter returns abnormal fault.

The possible reasons for no response to the communication:

Select wrong serial interface: for example, if the converter is COM1, select COM2 during the communication;

The baud rate, digital bit, end bit and check bit are not the same with the inverter;

+ and - of RS485 are connected in reverse;

The 485 wire cap on the terminal board of the inverter is not plugged in. The wire cap is behind the terminal block.

Extension card

Appendix A

A.1 What this chapter contains

This chapter describes the extension cards used in Goodrive300-02 series inverters.

A.2 PROFIBUS extension card

(1) PROFIBUS is an open international fieldbus standard that allows data exchange among various types of automation components. It is widely used in manufacturing automation, process automation and in other automation areas such as buildings, transportation, power, providing an effective solution for the realization of comprehensive automation and site-equipment intellectualization.

(2) PROFIBUS is composed of three compatible components, PROFIBUS-DP (Decentralized Periphery, distributed peripherals), PROFIBUS-PA (Process Automation), PROFIBUS-FMS (Fieldbus Message Specification). It is periodically exchange data with the inverter when using master-slave way. PRNV PROFIBUS-DP adapter module only supports PROFIBUS-DP protocol.

(3) The physical transmission medium of bus is twisted-pair (in line with RS-485 standard), two-wire cable or fiber optic cable. Baud rate is from 9.6Kbit/s to 12Mbit/s. The maximum bus cable length is between 100m and 1200m, specific length depending on the selected transmission rate (see chapter *Technical Data*). Up to 31 nodes can be connected to the same PROFIBUS network when repeaters aren't used. But, if use repeaters, up to 127 nodes can be connected to the same PROFIBUS network segment (including repeaters and master stations).

(4) In the process of PROFIBUS communication, tokens are assigned among main stations and master-slave transmission among master-slave stations. Supporting single-master or multi-master system, stations-programmable logic controller (PLC)-choose nodes to respond to the host instruction. Cycle master-from user data transmission and non-cyclic master-master station can also send commands to multiple nodes in the form of broadcast. In this case, the nodes do not need to send feedback signals to the host. In the PROFIBUS network, communication between nodes cannot be allowed.

(5) PROFIBUS protocol is described in detail in EN 50170 standard. To obtain more information about PROFIBUS, please refer to the above-mentioned EN 50170 standards.

A.2.1 Product naming rules

Fieldbus adapter naming rules, the product model:

EC-TX 1 03

① ② ③ ④

No.	Instruction	Meaning
①	Product type	EC: extension card
②	Card type	TX: communication card
③	Technical version	Odds such as 1,3,5,7 means the 1 st , 2 nd , 3 rd , 4 th technical version
④	Card difference	03: PROFIBUS+Ethernet communication card 04: Ethernet+CAN communication card

A.2.2 EC-TX-103 communication card

EC-TX-103 communication card is an optional device to inverter which makes inverter connected to PROFIBUS network. In PROFIBUS network, inverter is a subsidiary device. The following functions can be completed using EC-TX-103 communication card:

- Send control commands to inverter (start, stop, fault reset, etc.).
- Send speed or torque reference signal to inverter.
- Read state and actual values from inverter.
- Modify inverter parameter.

Please refer to the description of function codes in Group P15 for the commands supported by the inverter. Below is the structure diagram of the connection between the inverter and PROFIBUS:

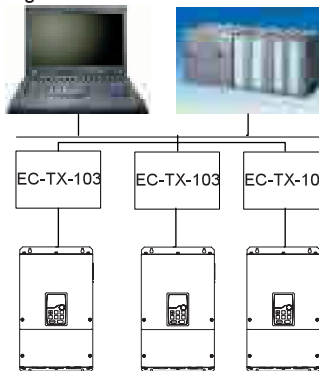

A.2.3 The appearance of EC-TX-103 communication card

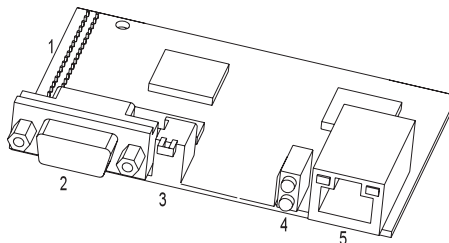

Outline diagram of EC-TX-103 communication card

1. Interface to control panel
2. Bus communication interface
3. Bus terminal
4. State display LEDs
5. Ethernet interface

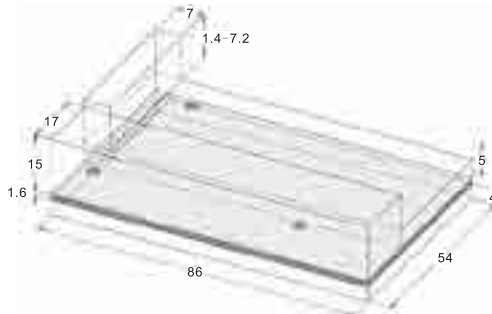

External dimensions of EC-TX-103 communication card (Unit: mm)

A.2.4 Compatible motor of EC-TX-103 communication card

EC-TX-103 communication card is compatible with the following products:

- Goodrive300-02 series devices and all inverters supporting PROFIBUS extension
- Host station supporting PROFIBUS-DP protocol

A.2.5 Delivery list

The package of EC-TX-103 communication card contains:

- EC-TX-103 communication card
- Three screws (M3x10)
- User manual

Please contact with the company or suppliers if there is something missing. Information may be subject to change without notice during product improving.

A.2.6 Installation of EC-TX-103 communication card

A.2.6.1 Mechanical installation of EC-TX-103 communication card

1. Installation ambient

- Ambient temperature: 0°C~+40°C
- Relative humidity: 5%~95%
- Other climate conditions: no condensation, ice, rain, snow or hail, solar radiation below 700W/m², air pressure 70~106kPa
- Content of salt spray and corrosive gases: pollution degree 2
- Content of dust and solid particles: pollution degree 2
- Vibration and shock: 5.9m/s² (0.6g) on 9~200Hz sinusoidal vibration

2. Installation steps:

- Fix the screws on the location holes with screws.
- Insert the module into the defined location carefully and fix it on the copper column with screws.
- Set the bus terminal switch of the module to the needed location.

3. Notes:

Disconnect the device from the power line before installation. Wait for at least three minutes to let the capacitors discharge. Cut off dangerous voltage from external control circuit to the unit output and input terminals.

Some electric components are sensitive to static charge. Do not touch the circuit board. If you have to operate it, please wear the grounding wrist belt.

A.2.6.2 Electrical installation of EC-TX-103 communication card

1. Node selection

Node address is the only address of PROFIBUS on the bus. The address which is among 00~99 is shown with two figures and is selected by the spinning switch on the module. The left switch shows the first number and the right one show the second number.

Node address=10 x the first digital value + the second digital value x 1

2. Bus terminals

There is a bus terminal in each heading and ending to avoid error during operation. The DIP switch on RPBA-01PCB is used to connect the bus terminals which can avoid the signal feedback from the bus cables. If the module is the first or last one in the internet, the bus terminal should be set as ON.

Please disconnect EC-TX-103 communication card terminals when the PROFIBUS D-sub connector with internal terminals is in use.

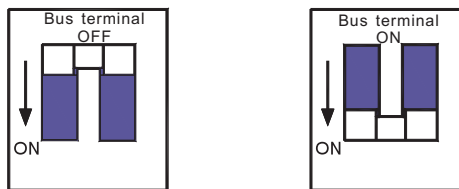

A.2.6.3 Bus net connection of EC-TX-103 communication card

1. Bus communication interface

Transformation by double-shielded twisted pair copper cable is the most common way in PROFIBUS (conform to RS-485 standard).

The basic characteristics of transmission technology:

- Net topology: Linear bus, there are bus resistor in two ends.
- Transmission speed: 9.6k bit/s~12M bit/s

- Medium: Double-shielded twisted pair cables, the shield can be removed according to the environment (EMC).
- Station number: There are 32 stations in each segment (without relays) up to 127 stations (with relays)
- Contact pin: 9 frames D pin, the connector contact pins are as below:

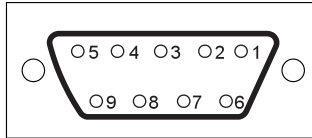

Contact pin of the connector		Instruction
1	-	Unused
2	-	Unused
3	B-Line	Positive data (twisted pair cables 1)
4	RTS	Sending requirement
5	GND_BUS	Isolation ground
6	+5V BUS	Isolated 5V DC power supply
7	-	Unused
8	A-Line	Negative data (twisted pair cables 2)
9	-	Unused
Housing	SHLD	PROFIBUS shielded cable

+5V and GND_BUS are used in the fieldbus terminals. Some devices, such as light transceiver (RS485) may get external power supply form these pins.

RTS is used in some devices to determine the sending direction. Only A-Line wires, B-Line wires and shield are used in the normal application.

It is recommended to apply the standard DB9 connector of SIEMENS. If the communication baud rate is above 187.5kbps, please follow the connection rules of SIEMENS seriously.



Available

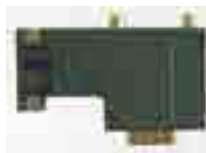

Not available (with interference to the keypad wiring)

2. Repeater

Up to 32 stations can be connected to each segment (master station or subsidiary stations), the repeater have to be used when stations is more than 32. The repeaters in series are generally no

more than 3.

Note: There is no repeater station address.

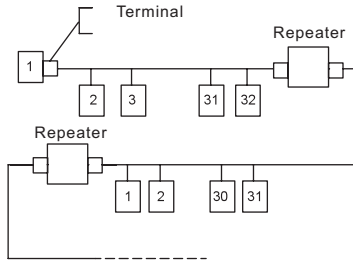

A.2.6.4 Transmission rate and maximum distance

Maximum length of cable depends on the transmission rate. The Table below shows the relationship between transmission rate and distance.

Transmission rate (kbps)	A-wire (m)	B-wire (m)
9.6	1200	1200
19.2	1200	1200
93.75	1200	1200
187.5	1000	600
500	400	200
1500	200	----
12000	100	----

Transmission line parameters:

Transmission rate (kbps)	A-wire (m)	B-wire (m)
Impedance (Ω)	135~165	100~130
Capacitance per unit length(pF/m)	< 30	< 60
Loop resistance (Ω /km)	110	-----
Core wire diameter (mm)	0.64	> 0.53
Line-core cross-section (mm ²)	> 0.34	> 0.22

Besides shielding twisted-pair copper wires, PROFIBUS can also use optical fiber for transmission in an electromagnetic interference environment to increase the high-speed transmission distance there are two kinds of fiber optical conductors, one is low-cost plastic fiber conductor, used distance is less than 50 meters, the other is glass fiber conductor, and used distance is less than 1km.

A.2.6.5 PROFIBUS bus connection diagram

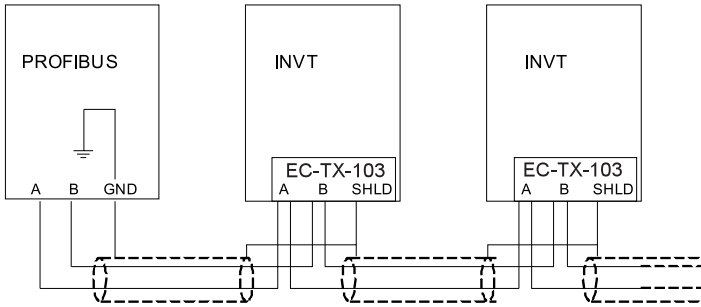

Above is "terminal" wiring diagram. Cable is a standard PROFIBUS cable consisting of a twisted pair and shielding layer. The shielded layer of PROFIBUS cable on all nodes is directly grounded. Users can choose the best grounding method according to the situation.

Note: Make sure that signal lines do not twist when connecting all stations. Shielded cable should be used when system runs under high electromagnetic interface environment, which can improve electromagnetic compatibility (EMC).

If using shielded braided wire and shielding foil, both ends should be connected to ground. Using shielding area should be large enough to maintain a good conductivity. And data lines must be separated from high-voltage.

Stub line segment should not be used when transmission rate more than 500K bit/s, The plug is available on the market which connects directly to data input and output cable. Bus plug connection can be on or off at any time without interruption of data communications of other station.

A.2.7 System configuration

1. Master station and inverter should be configured so that the master station can communicate with the module after correctly installing EC-TX-103 communication card.

Each PROFIBUS subsidiary station on the PROFIBUS bus need to have "device description document" named GSD file which used to describe the characteristics of PROFIBUS-DP devices. The software we provided for the user includes inverter related GSD files (device data files) information, users can obtain type definition file (GSD) of master machines from local INVT agent.

Configuration parameters of EC-TX-103 communication card:

Parameter number	Parameter name	Optional setting		Factory setting
0	Module type	Read only		PROFIBUS-DP
1	Node address	0~99		2
2	Baud rate setting	Kbit/s	0:9.6	6
			1:19.2	
			2:45.45	

			3:93.75	
			4:187.5	
			5:500	
		Mbit/s	6:1.5	
			7:3	
			8:6	
			9:9	
			10:12	
3	PZD3	0~65535		0
4	PZD4	The same as the above		0
...	The same as the above		0
10	PZD12	The same as the above		0

2. Module type

This parameter shows communication module type detected by inverter; users can not adjust this parameter. If this parameter is not defined, communication between the modules and inverter cannot be established.

3. Node address

In PROFIBUS network, each device corresponds to a unique node address, you can use the node address selection switch to define node address (switch isn't at 0) and the parameter is only used to display the node address.

If node address selection switch is 0, this parameter can define node address. The user can not adjust the parameter by themselves and the parameter is only used to display the node address.

4. GSD file

In PROFIBUS network, each PROFIBUS subsidiary station needs GSD file "device description document" which used to describe the characteristics of PROFIBUS-DP devices. GSD file contains all defined parameters, including baud rate, information length, amount of input/output data, meaning of diagnostic data.

A CD-ROM will be offered in which contains GSD file (extension name is .gsd) for fieldbus adapter. Users can copy GSD file to relevant subdirectory of configuration tools, please refer to relevant system configuration software instructions to know specific operations and PROFIBUS system configuration.

A.2.8 PROFIBUS-DP communication

1. PROFIBUS-DP

PROFIBUS-DP is a distributed I/O system, which enables master machine to use a large number of peripheral modules and field devices. Data transmission shows cycle: master machine read input information from subsidiary machine then give feedback signal. EC-TX-103 communication card supports PROFIBUS-DP protocol.

2. Service access point

PROFIBUS-DP has access to PROFIBUS data link layer (Layer 2) services through service access point SAP. Every independent SAP has clearly defined function. Please refer to relevant PROFIBUS user manual to know more about service access point information. PROFIDRIVE-Variable speed drive adopts PROFIBUS model or EN50170 standards (PROFIBUS protocol).

3. PROFIBUS-DP information frame data structures

PROFIBUS-DP bus mode allows rapid data exchange between master station and inverter. Adopting master-slave mode dealing with inverter access, inverter is always subsidiary station, and each has definite address. PROFIBUS periodic transmission messages use 16 words (16 bit) transmission, the structure shown in figure1.

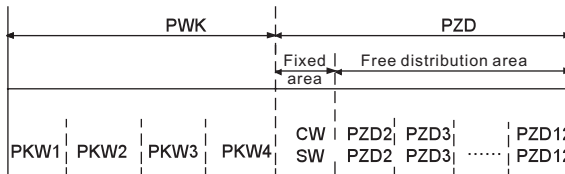

Parameters area:

PKW1-parameter identification

PKW2-array index number

PKW3-parameter value 1

PKW4-parameter value 2

Process data:

CW-control word (from master to slave)

SW-state word (from slave to master)

PZD-process data (decided by users) (From master to slave output **【reference value】** , from slave to master input **【actual value】**)

PZD area (process data area)

PZD area of communication message is designed for control and monitor inverter. PZD from master and slave station is addressed in high priority; the priority of dealing with PZD is superior to that of PKW, and always sends current valid date from interface.

Control word (CW) and state word (SW)

Control word (CW) is a basic method of fieldbus system controlling inverter. It is sent by the fieldbus master station to inverter and the EC-TX-103 communication cards act as gateway. Inverter responds according to the control word and gives feedbacks to master machine through state word (SW).

Reference value

Inverter can receive control information by several ways, these channels include: analog and digital input terminals, inverter control board and module communication (such as RS485, EC-TX-103 communication cards). In order to use PROFIBUS control inverter, the communication module must be set to be inverter controller.

Actual value

Actual value is a 16-bit word, which contains converter operation information. Monitoring capabilities are defined by inverter parameter. The integer scaling of actual value is sent to master machine depending on selected function, please refer to inverter manual.

Note: Inverter always check the control word (CW) and bytes of reference value.

Mission message (From master station to inverter)

Control word (CW)

The first word of PZD is control word (CW) of inverter; due to different control word (CW) of PWM rectifier regenerative part and inverter part illustration is depart in next two tables.

Control word (CW) of Goodrive300-02

Bit	Name	Value	State/Description
0~7	COMMAND BYTE	1	Forward running
		2	Reverse running
		3	Forward jogging
		4	Reverse jogging
		5	Decelerate to stop
		6	Coast to stop (Emergency stop)
		7	Fault reset
		8	Jogging stop
8	WRITE ENABLE	1	Write enable (mainly is PKW1-PKW4)
9~10	MOTOR GROUP SELECTION	00	MOTOR GROUP 1 SELECTION
		01	MOTOR GROUP 2 SELECTION
		02	MOTOR GROUP 3 SELECTION
		03	MOTOR GROUP 4 SELECTION

Bit	Name	Value	State/Description
11	TORQUE CONTROL SELECTION	1	Torque control enable
		0	Torque control disable
12	ELECTRIC CONSUMPTION CLEAR	1	Electric consumption clear enable
		0	Electric consumption clear disable
13	PRE-EXCIATION	1	Pre-excitation enable
		0	Pre-excitation disable
14	DC BRAKE	1	DC braking enable
		0	DC braking disable
15	HEARTBEAT REF	1	Heartbeat enable
		0	Heartbeat disable

Reference value (REF):

From 2nd word to 12th of PZD task message is the main set value REF, main frequency set value is offered by main setting signal source. As PWM rectifier feedback part doesn't have main frequency setting part, corresponding settings belong to reserved part, the following table shows inverter part settings for Goodrive300-02.

Bit	Name	Function selection
PZD2 receiving	0:Invalid 1:Set frequency(0~Fmax(unit:0.01Hz))	0
PZD3 receiving	2:PID reference, range(0~1000,1000 corresponds to 100.0%)	0
PZD4 receiving	3:PID feedback, range(0~1000,1000 corresponds to 100.0%)	0
PZD5 receiving	4:Torque set value(-3000~3000,1000 corresponds to 100.0% the rated current of the motor)	0
PZD6 receiving	5:Set value of the forward rotation upper-limit frequency(0~Fmax unit:0.01Hz)	0
PZD7 receiving	6:Set value of the reversed rotation upper-limit frequency(0~Fmax(unit:0.01Hz))	0
PZD8 receiving	7:Electromotion torque upper limit (0~3000,1000 corresponds to 100.0%of the rated current of the motor)	0
PZD9 receiving	8:Braking torque upper limit (0~2000,1000 corresponds to 100.0% of the rated current of the motor)	0
PZD10	9:Virtual input terminals command	0

Bit	Name	Function selection
receiving	Range:0x000~0x1FF	
PZD11 receiving	10:Virtual output terminals command Range:0x00~0x0F	0
PZD12 receiving	11:Voltage setting value(special for V/F separation) (0~1000,1000 corresponds to 100.0% the rated voltage of the motor) 12:AO output set value 1 (-1000~1000, 1000 corresponds to 100.0%) 13:AO output set value 2 (-1000~1000, 1000 corresponds to 100.0%)	0

State word (SW):

The first word of PZD response message is state word (SW) of inverter, the definition of state word is as follows:

State Word (SW) of Goodrive300-02 (SW)

Bit	Name	Value	State/Description
0~7	RUN STATE BYTE	1	Forward running
		2	Reverse running
		3	The inverter stops
		4	The inverter is in fault
		5	The inverter is in POFF state
		6	Pre-exciting state
8	DC VOLTAGE ESTABLISH	1	Running ready
		0	The running preparation is not ready
9~10	MOTOR GROUP FEEDBACK	0	Motor 1 feedback
		1	Motor 2 feedback
		2	Motor 3 feedback
		3	Motor 4 no feedback
11	MOTOR TYPE FEEDBACK	1	Synchronous motor
		0	Asynchronous motor
12	OVERLOAD ALARM	1	Overload pre-alarm
		0	Non-overload pre-alarm
13	RUN/STOP MODE	0	Keypad control
		1	Terminal control
14		2	Communication control

Bit	Name	Value	State/Description
		3	Reserved
15	HEARTBEAT FEEDBACK	1	Heartbeat feedback
		0	No heartbeat feedback

Actual value (ACT):

From 2nd word to 12th of PZD task message is main set value ACT, main frequency set value is offered by main setting signal source.

Actual value of Goodrive300-02

Bit	Name	Function selection
PZD2 sending	0: Invalid	0
	1:Running frequency(*100, Hz)	
PZD3 sending	2: Set frequency(*100, Hz)	0
	3: Bus voltage(*10, V)	
PZD4 sending	4: Output voltage(*1, V)	0
	5:Output current (*10, A)	
PZD5 sending	6:Output torque actual value(*10, %)	0
	7:Output power actual value (*10, %)	
PZD6 sending	8:Running rotating speed(*1, RPM)	0
	9:Running linear speed (*1, m/s)	
PZD7 sending	10:Ramp reference frequency	0
	11:Fault code	
PZD8 sending	12:AI1 value (*100, V)	0
	13:AI2 value (*100, V)	
PZD9 sending	14:AI3 value (*100, V)	0
	15:PULSE frequency value (*100,	
PZD10 sending	kHz)	0
	16:Terminals input state	
PZD11 sending	17:Terminals output state	0
	18:PID reference (*100, %)	
PZD12 sending	19:PID feedback (*100, %)	0
	20:Motor rated torque	

PKW area (parameter identification marks PKW1-value area). PKW area describes treatment of parameter identification interface, PKW interface is a mechanism which determine parameters transmission between two communication partners, such as reading and writing parameter values.

Structure of PKW area:

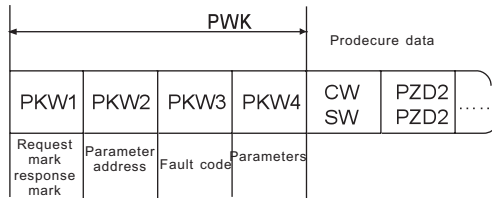

Parameter identification zone

In the process of periodic PROFIBUS-DP communication, PKW area is composed of four words (16 bit), each word is defined as follows:

The first word PKW1 (16 bit)		
Bit 15~00	Task or response identification marks	0~7
The second word PKW2 (16 bit)		
Bit 15~00	Basic parameters address	0~247
The third word PKW3 (16 bit)		
Bit 15~00	Parameter value (high word) or return error code value	00
The fourth word PKW4 (16 bit)		
Bit 15~00	Parameter value (low word)	0~65535

Note: If the master requests one parameter value, the value of PKW3 and PKW4 will not be valid.

Task requests and responses

When passing data to slave machine, master machine use request label while slave machine use response label to positive or negative confirmation. The following tables list the request/response function.

The definition of task logo PKW1 is as follows:

Definition of task logo PKW1

Request label (From master to slave)		Response label	
Request	Function	Positive confirmation	Negative confirmation
0	No task	0	—
1	Request parameter value	1,2	3
2	Modification parameter value (one word) [only change RAM]	1	3 or 4
3	Modification parameter value (double word) [only change RAM]	2	3 or 4
4	Modification parameter value (one word)	1	3 or 4

Request label (From master to slave)		Response label	
	[RAM and EEPROM are modified]		
5	Modification parameter value (double word) [RAM and EEPROM are modified]	2	3 or 4

Request label

"2"-modification parameter value (one word) [only change RAM],

"3"-modification parameter value (double word) [only change RAM]

"5"-modification parameter value (double word) [RAM and EEPROM are modified] not support currently.

Reponses logo PKW1 defines as below:

Response label (From slave to master)	
Confirmation	Function
0	No response
1	Transmission parameter value (one word)
2	Transmission parameter value (two word)
3	Task cannot be executed and returns the following error number: 0: Illegal parameter number 1: Parameter values cannot be changed (read-only parameter) 2: Out of set value range 3: The sub-index number is not correct 4: Setting is not allowed (only reset) 5: Data type is invalid 6: The task could not be implemented due to operational state 7: Request isn't supported. 8: Request can't be completed due to communication error 9: Fault occurs when write operation to stationary store 10: Request fails due to timeout 11: Parameter cannot be assigned to PZD 12: Control word bit can't be allocated 13: Other errors
4	No parameter change rights

Example 1: Read parameter value

Read keypad set frequency value (the address of keypad set frequency is 4) which can be achieved by setting PKW1 as 1, PKW2 as 4, return value is in PKW4.

Request (From master to inverter):

	PKW1		PKW2		PKW3		PKW4		CW		PZD2		PZD3		...	PZD12	
Request	00	01	00	04	00	00	00	00	xx	xx	xx	xx	xx	xx	...	xx	xx

0004: Parameter address
 0001: Request read parameter

Response (From inverter to master)

	PKW1		PKW2		PKW3		PKW4		CW		PZD2		PZD3		...	PZD12	
Response	00	01	00	04	00	00	05	00	xx	xx	xx	xx	xx	xx	...	xx	xx

0500: Address 4 parameter
 0001: Response (parameter values refreshed)

Example 2: Modify the parameter values (RAM and EEPROM are modified)

Modify keypad settings frequency value (the address of keypad set frequency is 4) which can be achieved by setting PKW1 as 2; PKW2 as 4, modification value (50.00) is in PKW4.

Request (From master to inverter):

	PKW1		PKW2		PKW3		PKW4		CW		PZD2		PZD3		...	PZD12	
Request	00	02	00	04	00	00	50	00	xx	xx	xx	xx	xx	xx	...	xx	xx

5000: Address 4 parameter
 0004: Parameter changes

Response (From inverter to master)

	PKW1		PKW2		PKW3		PKW4		CW		PZD2		PZD3		...	PZD12	
Response	00	01	00	04	00	00	05	00	xx	xx	xx	xx	xx	xx	...	xx	xx

0001: Response (parameter values refreshed)

Example for PZD:

Transmission of PZD area is achieved through inverter function code; please refer to relevant INVT inverter user manual to know relevant function code.

Example 1: Read process data of inverter

Inverter parameter selects "8: Run frequency" as PZD3 to transmit which can be achieved by setting Pd.14 as 8. This operation is mandatory until the parameter is instead of others.

Response (From inverter to master):

	PKW1		PKW2		PKW3		PKW4		CW		PZD2		PZD3		...	PZD12	
Response	xx	xx	xx	xx	xx	xx	xx	xx	xx	xx	xx	xx	00	0A	...	xx	xx

Example 2: Write process data into inverter

Inverter parameter selects "2": Traction given from PZD3 which can be achieved by setting Pd.03 as 2. In each request frame, parameters will use PZD3 to update until re-select a parameter.

Request (From master to inverter):

	PKW1		PKW2		PKW3		PKW4		CW		PZD2		PZD3		...	PZD12	
Response	xx	xx	xx	xx	xx	xx	xx	xx	xx	xx	xx	xx	00	00	...	xx	xx

In each request frame contents of PZD3 are given by traction until re-select a parameter.

A.2.9 Fault information

EC-TX-103 communication card is equipped with 2 fault display LEDs as shown is figure below. The roles of these LEDs are as follows:

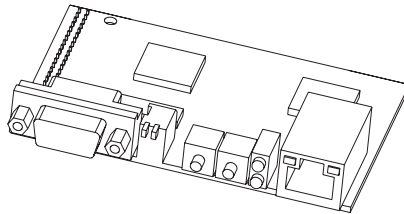

Fault display LEDs

LED No.	Name	Color	Function
1	Online	Green	ON-module online and data can be exchanged. OFF-module is not in "online" state.
2	Offline/Fault	Red	ON-module offline and data can't be exchanged. OFF-module is not in "offline" state. 1. Flicker frequency 1Hz-configuration error: The length of user parameter data sets is different from that of network configuration process during module initialization process. 2. Flicker frequency 2Hz-user parameter data error: The length or content of user parameter data sets is different from that of network configuration process during module initialization process. 3. Flicker frequency 4Hz-PROFIBUS communication ASIC initialization error. 4. OFF-Diagnostic closed.

A.3 CANopen optional cards

Refer to the operation manual of EC-TX105 CANopen communication card.

Technical data

Appendix B

B.1 What this chapter contains

This chapter contains the technical specifications of the inverter, as well as provisions for fulfilling the requirements for CE and other marks.

B.2 Ratings

B.2.1 Capacity

Inverter sizing is based on the rated motor current and power. To achieve the rated motor power given in the table, the rated current of the inverter must be higher than or equal to the rated motor current. Also the rated power of the inverter must be higher than or equal to the rated motor power.

Note:

1. The maximum allowed motor shaft power is limited to $1.5 \cdot P_N$. If the limit is exceeded, motor torque and current are automatically restricted. The function protects the input bridge of the drive against overload.
2. The ratings apply at ambient temperature of 40°C
3. It is important to check that in common DC systems the power flowing through the common DC connection does not exceed P_N .

B.2.2 Derating

The load capacity decreases if the installation site ambient temperature exceeds 40°C , the altitude exceeds 1000m or the switching frequency is changed from 4kHz to 8, 12 or 15kHz.

B.2.2.1 Temperature derating

In the temperature range $+40^\circ\text{C} \sim +50^\circ\text{C}$, the rated output current decreases by 3% for every additional 1°C . Refer to the below list for the actual derating.

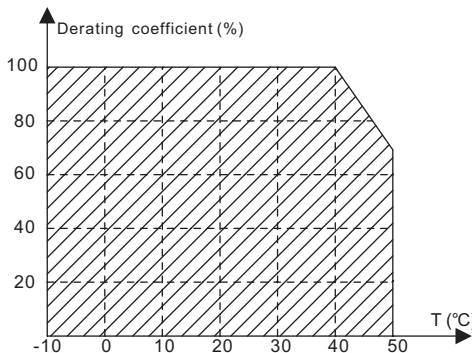

Note: Do not use the inverter when above 50°C ; otherwise, our company will not be responsible for any consequences.

B.2.2.2 Altitude derating

The device can output rated power if the installation site below 1000m. The output power decreases if the altitude exceeds 1000 meters. Below is the detailed decreasing range of the derating:

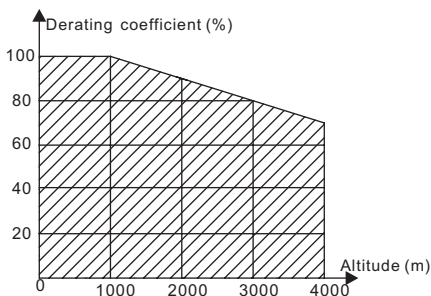

For 3-phase 200V inverter, the maximum altitude is 3000m above sea level. In altitudes 2000...3000m, the derating is 1% for every 100m.

B.2.2.3 Carrier frequency derating

For Goodrive300-02 series inverters, different power level corresponds to different carrier frequency range. The rated power of the inverter is based on the factory carrier frequency, so if it is above the factory value, the inverter needs to derate 20% for every additional 1kHz carrier frequency.

B.3 Grid specifications

Grid voltage	AC 3PH 380V (-15%)~440V (+10%)
Short-circuit capacity	Maximum allowed prospective short-circuit current at the input power connection as defined in IEC 60439-1 is 100kA. The drive is suitable for use in a circuit capable of delivering not more than 100kA at the drive maximum rated voltage.
Frequency	50/60Hz ± 5%, maximum rate of change 20%/s

B.4 Motor connection data

Motor type	Asynchronous induction motor or PMS motor
Voltage	0 to U1 (motor rated voltage), 3-phase symmetrical, Umax (inverter rated voltage) at the field weakening point
Short-circuit protection	The motor output is short-circuit proof by IEC 61800-5-1
Frequency	0~400Hz
Frequency resolution	0.01Hz

Current	Refer to Ratings
Power limit	1.5·PN
Field weakening point	10...400Hz
Carrier frequency	4, 8, 12 or 15kHz

B.4.1 EMC compatibility and motor cable length

To comply with the European EMC Directive (2004/108/EC), use the following maximum motor cable lengths for 4kHz switching frequency.

All frame sizes (with external EMC filter)	Maximum motor cable length (m)
Second environment (category C3)	30
First environment (category C2)	30

The maximum motor cable length is determined by the drive's operational factors. Contact the local representative for the exact maximum lengths when using external EMC filters.

For the instruction of the second environment (category C3) and first environment (category C2), please refer to *EMC regulations*.

B.5 Applicable standards

The inverter complies with the following standards:

EN/ISO 13849-1:2008	Safety of machinery–Safety related parts of control systems. Part 1: General principles for design
IEC/EN 60204-1:2006	Safety of machinery. Electrical equipment of machines. Part 1: General requirements
IEC/EN 62061:2005	Safety of machinery–Functional safety of safety-Related electrical, electronic and programmable electronic control systems
IEC/EN 61800-3:2004	Adjustable speed electrical power drive systems. Part 3: EMC requirements and specific test methods
IEC/EN 61800-5-1:2007	Adjustable speed electrical power drive systems–Part 5-1: Safety requirements–Electrical, thermal and energy
IEC/EN 61800-5-2:2007	Adjustable speed electrical power drive systems–Part 5-2: Safety requirements–Functional

B.5.1 CE marking

The CE mark is attached to the drive to verify that the drive follows the provisions of the European Low Voltage and EMC Directives.

B.5.2 Compliant with EMC regulations

The EMC Directive defines the requirements for immunity and emissions of electrical equipment used within the European Union. The EMC product standard (EN 61800-3:2004) covers requirements stated for drives. See section *EMC regulations*.

B.6 EMC regulations

EMC product standard (EN 61800-3:2004) contains the EMC requirements to the inverter.

First environment: domestic environment (includes establishments connected to a low-voltage network which supplies buildings used for domestic purposes).

Second environment includes establishments connected to a network not directly supplying domestic premises.

Four categories of the inverter:

Inverter of category C1: inverter of rated voltage less than 1000V and used in the first environment.

Inverter of category C2: inverter of rated voltage less than 1000V other than pins, sockets and motion devices and intended to be installed and operated only by a professional electrician when used in the first environment.

Note: IEC/EN 61800-3 in EMC standard does not limit the power distribution of the inverter, but it defines the usage, installation and commissioning. The professional electrician needs the skills in installing and/or commissioning electrical drive systems, including EMC aspects.

Inverter of category C3: inverter of rated voltage less than 1000V and used in the second environment other than the first one

Inverter of category C4: inverter of rated voltage more than 1000V or the rated current is above or equal to 400A and used in the complicated system in second environment

B.6.1 Category C2

The emission limits comply with the following provisions:

1. The optional EMC filter is selected according to the options and installed as specified in the EMC filter manual.
2. The motor and control cables are selected as specified in this manual.
3. The inverter is installed according to the instructions given in this manual.
4. For the maximum motor cable length with 4kHz switching frequency, see *EMC compatibility and motor cable length*.



⇨ In a domestic environment, this product may cause radio interference, in which case supplementary mitigation measures may be required.

B.6.2 Category C3

The immunity performance of the drive complies with the demands of IEC/EN 61800-3, second

environment.

The emission limits comply with the following provisions:

1. The optional EMC filter is selected according to the options and installed as specified in the EMC filter manual.
2. The motor and control cables are selected as specified in this manual.
3. The inverter is installed according to the instructions given in this manual.
4. For the maximum motor cable length with 4kHz switching frequency, see ***EMC compatibility and motor cable length***.



↔ The inverter of category C3 is not intended to be used on a low-voltage public network which supplies domestic premises. Radio frequency interference is expected if the inverter is used on such a network.

Dimension drawings

Appendix C

C.1 What this chapter contains

Dimension drawings of the Goodrive300-02 are shown below. The dimensions are given in millimeters.

C.2 Overall dimension

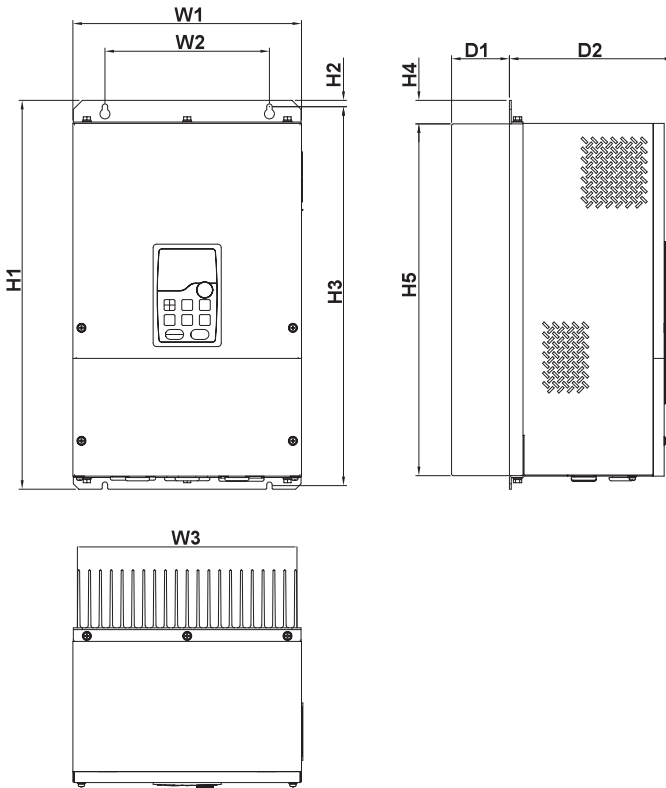

Model	W1	W2	W3	H1	H2	H3	H4	H5	D1	D2
7.5kW~18.5kW	230	160	194	419	7	408	26	379	65	154.5
22kW~30kW	253	182	243	430.2	7	419	26	389.2	64	181.7
37kW~55kW	320	220	290.5	515.3	7	504	26	474	79	282.2

C.3 Installation dimension

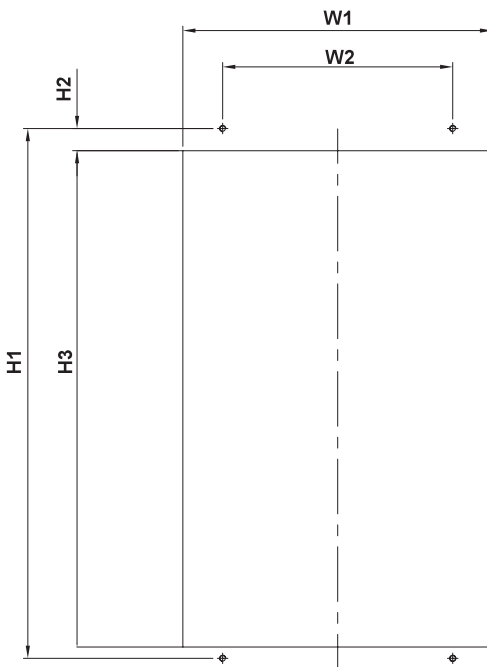

Model	W1	W2	H1	H2	H3	Hole size
7.5kW~18.5kW	198	160	408	17	383	7
22kW~30kW	245	182	419	17.5	392.5	7
37kW~55kW	295	220	504	16.5	478	7

Peripheral options and parts

Appendix D

D.1 What this chapter contains

This chapter describes how to select the options and parts of Goodrive300-02 series.





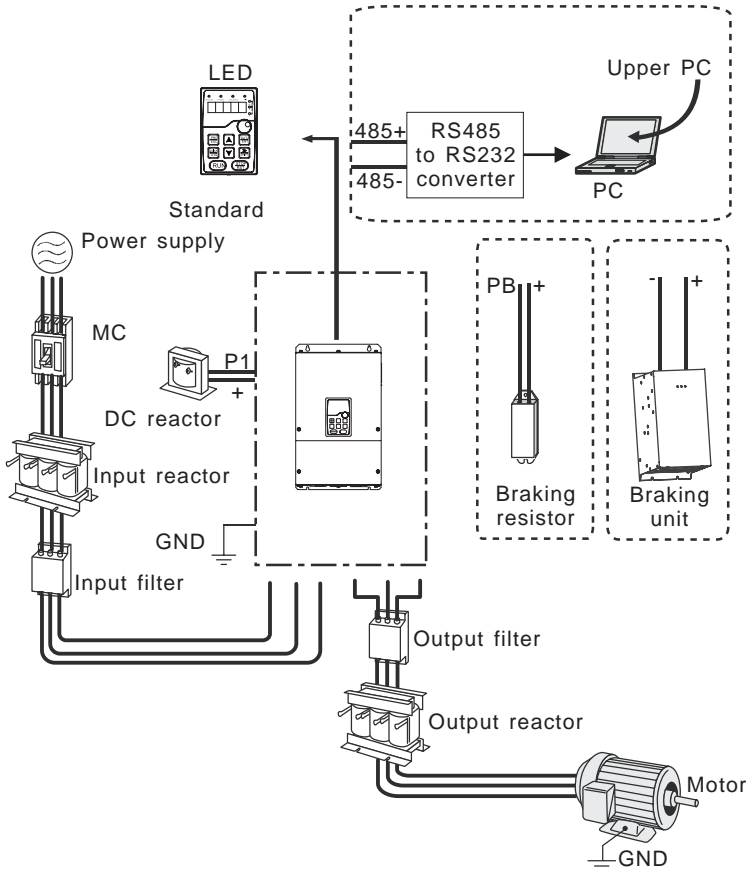

D.2 Peripheral wiring

Below is the peripheral wiring of Goodrive300-02 series inverters.

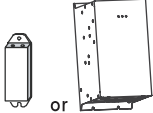

Note:

1. The inverters of 380V ($\leq 18.5\text{kW}$) are embedded with braking unit.
2. The inverters of 380V ($\geq 37\text{kW}$) have P1 terminal and can be connected with external DC reactors.
3. The braking units apply standard braking units. Refer to the instruction of DBU for detailed information.

Pictures	Name	Descriptions
	Cables	Device to transfer the electronic signals
	Breaker	Prevent from electric shock and protect the power supply and the cables system from overcurrent when short circuits occur. (Please select the breaker with the function of reducing high order harmonic and the rated sensitive current to 1 inverter should be above 30mA).
	Input reactor	This devices are used to improve the power factor of the input side of the inverter and control the higher harmonic current.
	DC reactor	
	Input filter	Control the electromagnetic interference generated from the inverter, please install close to the input terminal side of the inverter.
	Braking unit or resistors	Shorten the DEC time The inverters of 380V ($\leq 18.5\text{kW}$) only need braking resistors while the inverters of 380V ($\geq 22\text{kW}$) need braking units besides braking resistors.
	Output filter	Control the interference from the output side of the inverter and please install close to the output terminals of the inverter.
	Output reactor	Prolong the effective transmitting distance of the inverter to control the sudden high voltage when switching on/off the IGBT of the inverter.

D.3 Power supply

Please refer to *Electric installation*.

	⚡ Check that the voltage degree of the inverter complies with the voltage of the grid.
---	--

D.4 Cables

D.4.1 Power cables

The dimensions of input power cables and motor cables should comply with local regulations.

- The input power and motor cables must be able to carry the corresponding load current.
- The cable must be rated for at least 70°C maximum permissible temperature of the conductor in continuous use.
- The conductivity of the PE conductor must be equal to that of the phase conductor (same cross-sectional area).
- Refer to chapter *Technical data* for the EMC requirements.

A symmetrical shielded motor cable (see the figure below) must be used to meet the EMC requirements of the CE.

A 4-core conductor system is allowed for input cables, but a shielded symmetrical cable is recommended. Compared to a 4-core conductor system, the use of a symmetrical shielded cable reduces electromagnetic emission of the whole drive system as well as motor bearing current and wear.

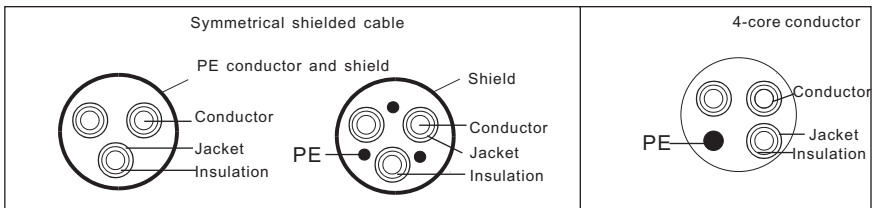

Note: A separate PE conductor is required if the conductivity of the cable shield is not sufficient for the purpose.

To function as a protective conductor, the shield must have the same cross-sectional area as the phase conductors when they are made of the same metal.

To effectively suppress radiated and conducted radio-frequency emissions, the shield conductivity must be at least 1/10 of the phase conductor conductivity. The requirements are easily met with a copper or aluminum shield. The minimum requirement of the motor cable shield of the drive is shown below. It consists of a concentric layer of copper wires. The better and tighter the shield, the lower the emission level and bearing currents.

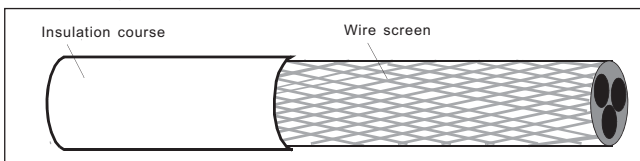

Cross section of the cable

D.4.2 Control cables

All analog control cables and the cable used for the frequency input must be shielded. Use a double-shielded twisted pair cable (Figure a) for analog signals. Employ one individually shielded pair for each signal. Do not use common return for different analog signals.

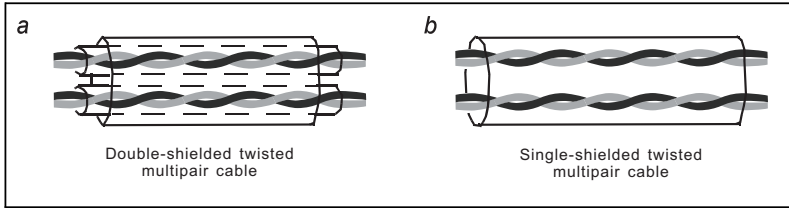

Power cables routing

A double-shielded cable is the best alternative for low-voltage digital signals, but a single-shielded or unshielded twisted multipair cable (Fig b) is also usable. However, for frequency input, always use a shielded cable.

The relay cable needs the cable type with braided metallic screen.

The keypad needs to connect with cables. It is recommended to use the screen cable on complex electrical magnetic condition.

Note: Run analog and digital signals in separate cables.

Do not make any voltage tolerance or insulation resistance tests (for example hi-pot or megger) on any part of the drive as testing can damage the drive. Every drive has been tested for insulation between the main circuit and the chassis at the factory. Also, there are voltage-limiting circuits inside the drive which cut down the testing voltage automatically.

Note: Check the insulation of the input power cable according to local regulations before connecting to the drive.

D.4.2.1 AC 3PH 380V(-15%)~440V(+10%)

Inverter model	Recommended cable size (mm ²)		Connecting cable size (mm ²)				Terminal screw	Tightening torque (Nm)
	RST UVW	PE	RST UVW	P1, (+)	PB (+), (-)	PE		
GD300-02-7R5G-4	4	4	4~16	4~16	4~16	4~16	M5	2~2.5
GD300-02-011G-4	6	6	6~16	6~16	6~16	6~16	M5	2~2.5
GD300-02-015G-4	10	10	10~25	10~25	10~25	6~25	M5	2~2.5
GD300-02-018G-4	16	16	16~25	16~25	16~25	10~25	M5	2~2.5
GD300-02-022G-4	16	16	16~25	16~25	16~25	10~25	M6	4~6
GD300-02-030G-4	25	16	16~25	16~25	16~25	16~25	M6	4~6

Inverter model	Recommended cable size (mm ²)		Connecting cable size (mm ²)				Terminal screw	Tightening torque (Nm)
	RST UVW	PE	RST UVW	P1, (+)	PB (+), (-)	PE		
GD300-02-037G-4	25	16	25~50	25~50	25~50	16~50	M8	9~11
GD300-02-045G-4	35	16	25~50	25~50	25~50	16~50	M8	9~11
GD300-02-055G-4	50	25	50~95	50~95	50~95	25~50	M8	9~11

Note:

1. It is appropriate to use the recommended cable size under 40°C and rated current. The wiring distance should be no more than 100m.
2. Terminals P1, (+), PB and (-) connect the DC reactor and braking parts.

D.4.3 Routing the cables

Route the motor cable away from other cable routes. Motor cables of several drives can be run in parallel installed next to each other. It is recommended that the motor cable, input power cable and control cables are installed on separate trays. Avoid long parallel runs of motor cables with other cables to decrease electromagnetic interference caused by the rapid changes in the drive output voltage.

Where control cables must cross power cables make sure that they are arranged at an angle as near to 90 degrees as possible.

The cable trays must have good electrical bonding to each other and to the grounding electrodes. Aluminum tray systems can be used to improve local equalizing of potential.

A figure of the cable routing is shown below.

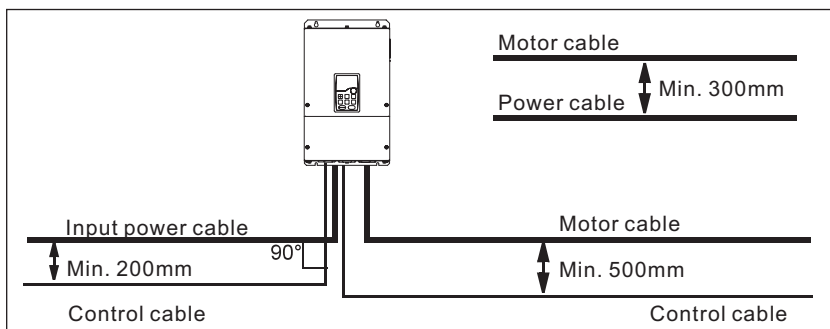

Routing distances

D.4.4 Insulation checking

Check the insulation of the motor and motor cable as follows:

1. Check that the motor cable is connected to the motor and disconnected from the drive output

terminals U, V and W.

2. Measure the insulation resistance between each phase conductor and the PE conductor using a measuring voltage of 500V DC. For the insulation resistance of other motors, please consult the manufacturer's instructions.

Note: Moisture inside the motor casing will reduce the insulation resistance. If moisture is suspected, dry the motor and repeat the measurement.

D.5 Breaker and electromagnetic contactor

It is necessary to add fuse for the avoidance of overload.

It is appropriate to use a breaker (MCCB) which complies with the inverter power in the 3-phase AC power and input power and terminals (R, S, T). The capacity of the inverter should be 1.5-2 times of the rated current.

	<p>↷ Due to the inherent operating principle and construction of circuit breakers, independent of the manufacturer, hot ionized gases may escape from the breaker enclosure in case of a short-circuit. To ensure safe use, special attention must be paid to the installation and placement of the breakers. Follow the manufacturer's instructions.</p>
---	---

It is necessary to install the electromagnetic contactor in the input side to control the switching on and off safety of the main circuit. It can switch off the input power supply when system fault.

D.5.1 AC 3PH 380V(-15%)~440V(+10%)

Inverter model	Fuse (A)	Breaker (A)	Rated working current of the contactor (A)
GD300-02-7R5G-4	60	40	25
GD300-02-011G-4	78	63	32
GD300-02-015G-4	105	63	50
GD300-02-018G-4	114	100	63
GD300-02-022G-4	138	100	80
GD300-02-030G-4	186	125	95
GD300-02-037G-4	228	160	120
GD300-02-045G-4	270	200	135
GD300-02-055G-4	315	200	170

D.6 Reactors

High current in the input power circuit may cause damage to the rectifying components. It is appropriate to use AC reactor in the input side for the avoidance of high-voltage input of the power supply and improvement of the power factors.

If the distance between the inverter and the motor is longer than 50m, frequent overcurrent protection may occur to the inverter because of high leakage current caused by parasitic capacitance effects from the long cables to the ground. In order to avoid the damage of the motor insulation, it is necessary to add reactor compensation.

The inverters of 380V ($\geq 37\text{kW}$) can be equipped with external DC reactors for the improvement of power factors and the avoidance of damage from high input current to the rectifying components because of the high-capacity transformer. The device can also cease the damage to the rectifying components which are caused by supply net voltage transients and harmonic waves of the loads.

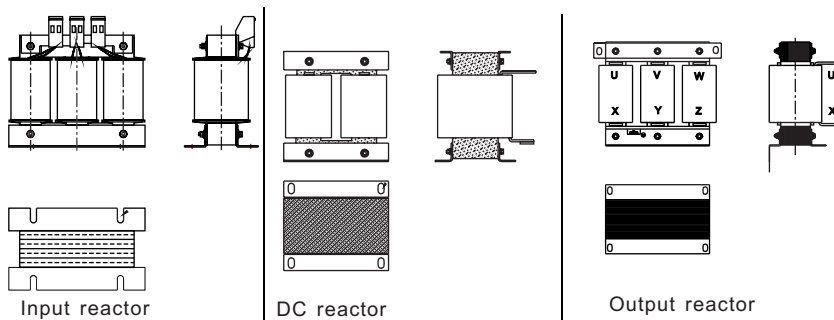

D.6.1 AC 3PH 380V(-15%)~440V(+10%)

Inverter model	Input reactor	DC reactor	Output reactor
GD300-02-7R5G-4	ACL2-7R5-4	/	OCL2-7R5-4
GD300-02-011G-4	ACL2-011-4	/	OCL2-011-4
GD300-02-015G-4	ACL2-015-4	/	OCL2-015-4
GD300-02-018G-4	ACL2-018-4	/	OCL2-018-4
GD300-02-022G-4	ACL2-022-4	/	OCL2-022-4
GD300-02-030G-4	ACL2-030-4	/	OCL2-030-4
GD300-02-037G-4	ACL2-037-4	DCL2-037-4	OCL2-037-4
GD300-02-045G-4	ACL2-045-4	DCL2-045-4	OCL2-045-4
GD300-02-055G-4	ACL2-055-4	DCL2-055-4	OCL2-055-4

Note:

1. The rated derate voltage of the input reactor is $2\% \pm 15\%$.
2. The power factor of the input side is above 90% after installing DC reactor.
3. The rated derate voltage of the output reactor is $1\% \pm 15\%$.
4. Above options are external, the customer should indicate when purchasing.

D.7 Filters

Goodrive300-02 series inverters have embedded C3 filters which can be connected by J10.

Note: Do not connect C3 filter in IT power supply system.

The input interference filter can decrease the interference of the inverter to the surrounding equipments.

Output interference filter can decrease the radio noise cause by the cables between the inverter and the motor and the leakage current of the conducting wires.

Our company configured some filters for the convenience of the users.

D.7.1 Filter type instruction

FLT-P04045L-B

A
B
C
D
E
F

Character designation	Detailed instruction
A	FLT: inverter filter series
B	Filter type P: power supply filter L: output filter
C	Voltage degree 04: AC 3PH 380V(-15%)~440V(+10%)
D	3 bit rated current code, "015" means 15A
E	Filter performance L: Common type H: High performance type
F	Utilization environment of the filters A: the first environment (IEC61800-3:2004) category C1 (EN 61800-3:2004) B: the first environment (IEC61800-3:2004) category C2 (EN 61800-3:2004) C: the second environment (IEC61800-3:2004) category C3 (EN 61800-3:2004)

D.7.2 AC 3PH 380V(-15%)~440V(+10%)



Inverter model	Input filter	Output filter
GD300-02-7R5G-4	FLT-P04032L-B	FLT-L04032L-B
GD300-02-011G-4		
GD300-02-015G-4	FLT-P04045L-B	FLT-L04045L-B
GD300-02-018G-4		

Inverter model	Input filter	Output filter
GD300-02-022G-4	FLT-P04065L-B	FLT-L04065L-B
GD300-02-030G-4		
GD300-02-037G-4	FLT-P04100L-B	FLT-L04100L-B
GD300-02-045G-4		
GD300-02-055G-4	FLT-P04150L-B	FLT-L04150L-B

D.8 Braking system

D.8.1 Select the braking components

It is appropriate to use braking resistor or braking unit when the motor brakes sharply or the motor is driven by a high inertia load. The motor will become a generator if its actual rotating speed is higher than the corresponding speed of the reference frequency. As a result, the inertial energy of the motor and load return to the inverter to charge the capacitors in the main DC circuit. When the voltage increases to the limit, damage may occur to the inverter. It is necessary to apply braking unit/resistor to avoid this accident happens.

	<ul style="list-style-type: none"> ◇ Only qualified electricians are allowed to design, install, commission and operate the inverter. ◇ Follow the instructions in “warning” during working; otherwise, physical injury or death or serious property may occur. ◇ Only qualified electricians are allowed to wire; otherwise, damage to the inverter or braking options and parts may occur. ◇ Read the instructions of braking resistors or units carefully before connecting them with the inverter. ◇ Do not connect the braking resistor with other terminals except for PB and (+). Otherwise, damage to the inverter or braking circuit or fire may occur. ◇ Do not connect the braking unit with other terminals except for (+) and (-).
	<ul style="list-style-type: none"> ◇ Connect the braking resistor or braking unit with the inverter according to the diagram. Incorrect wiring may cause damage to the inverter or other devices.

D.8.1.1 AC 3PH 380V(-15%)~440V(+10%)

Goodrive300-02 inverters of 380V ($\leq 18.5\text{kW}$) have embedded braking units but the inverters of 380V ($\geq 22\text{kW}$) have optional braking units. Please select the resistance and power of the braking resistor according to actual operation (the requirements of braking torque and usage ratio).



Inverter model	Model of braking unit	Braking resistance at 100% of the braking torque (Ω)	The consumed power of the braking resistor			Min. allowable braking resistance (Ω)
			10% braking	50% braking	80% braking	
GD300-02-7R5G-4	Embedded braking units	65	1.1	5.6	9	47
GD300-02-011G-4		44	1.7	8.3	13.2	31
GD300-02-015G-4		32	2	11	18	23
GD300-02-018G-4		27	3	14	22	19
GD300-02-022G-4	DBU100H-060-4	22	3	17	26	17
GD300-02-030G-4		17	5	23	36	17
GD300-02-037G-4		13	6	28	44	11.7
GD300-02-045G-4		10	7	34	54	6.4
GD300-02-055G-4	8	8	41	66		

Note:

Select the resistance and power of the braking resistor according to the data our company provided.

The braking resistor may increase the braking torque of the inverter. The resistor power in the above table is designed on 100% braking torque, 10%, 50% and 80% braking usage ratio. Users can select braking system according to the actual operation.

When using the external braking units, please see the instructions of the energy braking units to set the voltage degree of the braking unit. Incorrect voltage degree may affect the normal running of the inverter.

	⚡ Never use a brake resistor with a resistance below the minimum value specified for the particular inverter. The internal inverter are not able to handle the overcurrent caused by the low resistance.
	⚡ Increase the power of the braking resistor properly in the frequent braking situation (the frequency usage ratio is more than 10%).

D.8.2 Select the braking resistor cables

Use a shielded cable to the resistor cable.

D.8.3 Install the braking resistors

Install all resistors in a place with good ventilation.

	⚡ The materials near the braking resistors must be non-flammable. The surface temperature of the resistor is high. Air flowing from the resistor is of hundreds of
---	--

	degrees Celsius. Protect the resistor against contact.
--	--

Installation of the braking resistor:

	<ul style="list-style-type: none"> ◇ The inverters of 380V (≤ 18.5) only need external braking resistors. ◇ PB and (+) are the wiring terminals of the braking resistors.
---	---

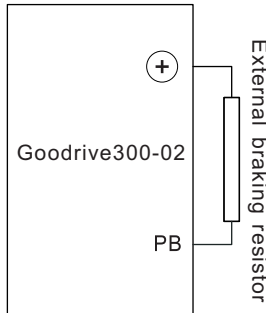

Installation of the braking unit:

	<ul style="list-style-type: none"> ◇ The inverters of 380V ($\geq 22\text{kW}$) need external braking units. ◇ (+), (-) are the wiring terminals of the braking units. ◇ The wiring length between the (+), (-) terminals of the inverter and the (+), (-) terminals of the braking units should be no more than 5m, and the distributing length among BR1 and BR2 and the braking resistor terminals should be no more than 10m.
---	---

Single installation is as follows:

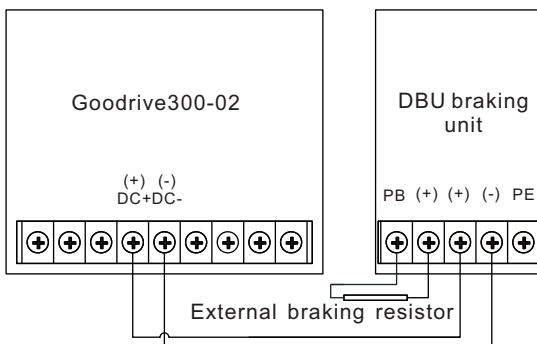

Further information

Appendix E

E.1.1 Product and service inquire

Address any inquiries about the product to your local INVT offices, quoting the type designation and serial number of the unit in question. A listing of INVT sales, support and service contacts can be found on www.invt.com.cn.

E.1.2 Feedback on INVT inverter manuals

Your comments on our manuals are welcome. Go to www.invt.com.cn and select *Online Feedback of Contact Us*.

E.1.3 Documents on the internet

You can find manuals and other product documents in PDF format on the internet. Go to www.invt.com.cn and select *Service and Support of Document Download*.



Service line:86-755-86312859 E-mail:overseas@invt.com.cn Website:www.invt.com

SHENZHEN INVT ELECTRIC CO., LTD. No. 4 Building, Gaofa Scientific Industrial Park, Longjing, Nanshan District, Shenzhen, China

- Industrial Automation: Frequency Inverter Servo & Motion Control Motor & Electric Spindle PLC
 HMI Intelligent Elevator Control System Traction Drive
- Electric Power: SVG Solar Inverter UPS Online Energy Management System



66001-00257