

# SIEMENS



Operating instructions

# SINAMICS

## SINAMICS G120X

Infrastructure converter  
for HVAC/water/wastewater

Edition

03/2019

[www.siemens.com/drives](http://www.siemens.com/drives)



# SIEMENS

## SINAMICS

### SINAMICS G120X SINAMICS G120X converter

#### Operating Instructions

Fundamental safety instructions	1
Description	2
Mounting	3
Wiring	4
Commissioning	5
Advanced commissioning	6
Parameters	7
Saving the settings and series commissioning	8
Warnings, faults and system messages	9
Corrective maintenance	10
Technical data	11
Appendix	A

Edition 03/2019, firmware V1.0

## Legal information

### Warning notice system

This manual contains notices you have to observe in order to ensure your personal safety, as well as to prevent damage to property. The notices referring to your personal safety are highlighted in the manual by a safety alert symbol, notices referring only to property damage have no safety alert symbol. These notices shown below are graded according to the degree of danger.

<b>⚠ DANGER</b>
indicates that death or severe personal injury <b>will</b> result if proper precautions are not taken.

<b>⚠ WARNING</b>
indicates that death or severe personal injury <b>may</b> result if proper precautions are not taken.

<b>⚠ CAUTION</b>
indicates that minor personal injury can result if proper precautions are not taken.

<b>NOTICE</b>
indicates that property damage can result if proper precautions are not taken.

If more than one degree of danger is present, the warning notice representing the highest degree of danger will be used. A notice warning of injury to persons with a safety alert symbol may also include a warning relating to property damage.

### Qualified Personnel

The product/system described in this documentation may be operated only by **personnel qualified** for the specific task in accordance with the relevant documentation, in particular its warning notices and safety instructions. Qualified personnel are those who, based on their training and experience, are capable of identifying risks and avoiding potential hazards when working with these products/systems.

### Proper use of Siemens products

Note the following:

<b>⚠ WARNING</b>
Siemens products may only be used for the applications described in the catalog and in the relevant technical documentation. If products and components from other manufacturers are used, these must be recommended or approved by Siemens. Proper transport, storage, installation, assembly, commissioning, operation and maintenance are required to ensure that the products operate safely and without any problems. The permissible ambient conditions must be complied with. The information in the relevant documentation must be observed.

### Trademarks

All names identified by ® are registered trademarks of Siemens AG. The remaining trademarks in this publication may be trademarks whose use by third parties for their own purposes could violate the rights of the owner.

### Disclaimer of Liability

We have reviewed the contents of this publication to ensure consistency with the hardware and software described. Since variance cannot be precluded entirely, we cannot guarantee full consistency. However, the information in this publication is reviewed regularly and any necessary corrections are included in subsequent editions.

# Table of contents

<b>1</b>	<b>Fundamental safety instructions</b> .....	<b>11</b>
1.1	General safety instructions.....	11
1.2	Equipment damage due to electric fields or electrostatic discharge.....	17
1.3	Warranty and liability for application examples.....	18
1.4	Industrial security.....	19
1.5	Residual risks of power drive systems.....	21
<b>2</b>	<b>Description</b> .....	<b>23</b>
2.1	About the Manual.....	23
2.2	About the converter.....	24
2.3	Scope of delivery.....	25
2.4	Directives and standards.....	29
2.5	Device disposal.....	31
2.6	Optional components.....	32
2.6.1	External line filter.....	32
2.6.2	Line reactor.....	33
2.6.3	Output reactor.....	35
2.6.4	Sine-wave filter.....	36
2.6.5	Line harmonics filter.....	37
2.6.6	dv/dt filter plus VPL.....	38
2.6.7	Push-through mounting kit.....	39
2.6.8	Mounting grips for push-through mounted converters.....	42
2.6.9	IP21 top cover.....	42
2.6.10	Operator panel.....	44
2.6.11	SINAMICS G120 Smart Access.....	44
2.7	Motors and multi-motor drives that can be operated.....	45
<b>3</b>	<b>Mounting</b> .....	<b>47</b>
3.1	Installing the label for the North American market.....	47
3.2	EMC-compliant setup of the machine or plant.....	48
3.2.1	Control cabinet.....	49
3.2.2	Cables.....	50
3.2.3	Electromechanical components.....	52
3.3	Power losses and air cooling requirements.....	53
3.4	Mounting the converter.....	55
3.4.1	Basic installation rules.....	55
3.4.2	Dimension drawings and drill patterns.....	57
3.4.2.1	Mounting the converter on the mounting panel.....	58
3.4.2.2	Mounting the converter utilizing push-through technology (FSA to FSG only).....	60

3.4.3	Mounting the shield connection kits .....	63
3.4.4	Additional mounting instructions for FSD ... FSJ.....	65
3.4.4.1	Additional mounting instructions, FSD ... FSG.....	65
3.4.4.2	Additional mounting instructions, FSH/FSJ.....	68
3.4.5	Mounting the optional components .....	69
<b>4</b>	<b>Wiring .....</b>	<b>71</b>
4.1	Line supply and motor .....	71
4.1.1	Permissible line supplies .....	71
4.1.1.1	TN system .....	71
4.1.1.2	TT system .....	73
4.1.1.3	IT system.....	74
4.1.1.4	Removing functional grounding of the converter.....	74
4.1.2	Minimum cross-section of the protective conductor .....	76
4.1.3	Maximum permissible motor cable length.....	78
4.1.4	Connecting the converter and converter components .....	83
4.1.4.1	Connection overview .....	83
4.1.4.2	Connecting converters .....	84
4.1.4.3	Cable cross-sections and screw tightening torques .....	88
4.1.4.4	Cable lug .....	90
4.1.4.5	Connecting the cable shields (FSA ... FSG only).....	90
4.1.5	Connecting the motor to the converter in a star or delta connection.....	93
4.2	Control interfaces .....	94
4.2.1	Overview of the interfaces.....	94
4.2.2	Fieldbus interface allocation.....	95
4.2.3	Terminal strips.....	96
4.2.4	Factory interface settings .....	99
4.2.5	Default setting of the interfaces.....	100
4.2.6	Additional digital inputs and digital outputs on converters FSH and FSJ.....	104
4.2.7	"Safe Torque Off" safety function.....	106
4.2.8	Application examples for "Safe Torque Off" .....	110
4.2.9	Wiring the terminal strips.....	117
4.2.10	Connecting to PROFINET and Ethernet .....	119
4.2.10.1	Communication via PROFINET IO and Ethernet .....	119
4.2.10.2	Connecting the PROFINET cable to the converter .....	120
4.2.10.3	What do you have to set for communication via PROFINET? .....	120
4.2.10.4	Installing GSDML .....	121
<b>5</b>	<b>Commissioning .....</b>	<b>123</b>
5.1	Commissioning guidelines .....	123
5.2	Tools .....	124
5.3	Preparing for commissioning.....	125
5.3.1	Collecting motor data .....	125
5.3.2	Forming DC link capacitors .....	127
5.3.3	Converter factory setting .....	129
5.4	Quick commissioning using the BOP-2 operator panel.....	131
5.4.1	Fitting the BOP-2 to the converter.....	131
5.4.2	Overview of quick commissioning .....	132
5.4.3	Start quick commissioning and select the application class.....	133
5.4.4	Selecting an application class .....	134

5.4.5	Standard Drive Control.....	135
5.4.6	Dynamic Drive Control .....	137
5.4.7	Expert.....	139
5.4.8	Identifying the motor data and optimizing the closed-loop control .....	143
5.5	Restoring the factory settings.....	145
<b>6</b>	<b>Advanced commissioning.....</b>	<b>147</b>
6.1	Overview of the converter functions.....	147
6.2	Drive control .....	149
6.2.1	Sequence control when switching the motor on and off.....	149
6.2.2	Adapt the default setting of the terminal strips .....	153
6.2.2.1	Digital inputs.....	155
6.2.2.2	Analog input as digital input .....	158
6.2.2.3	Digital outputs .....	160
6.2.2.4	Analog inputs .....	165
6.2.2.5	Adjusting characteristics for analog input.....	168
6.2.2.6	Setting the deadband .....	169
6.2.2.7	Analog outputs .....	171
6.2.2.8	Adjusting characteristics for analog output .....	173
6.2.3	Drive control via PROFINET .....	174
6.2.3.1	Receive data and send data .....	174
6.2.3.2	Telegrams .....	175
6.2.3.3	Parameter channel.....	182
6.2.3.4	Expanding or freely interconnecting telegrams .....	187
6.2.3.5	Acyclically reading and writing converter parameters .....	189
6.2.3.6	Reading and changing parameters via data set 47.....	189
6.2.4	Communication via EtherNet/IP .....	193
6.2.4.1	Connect converter to EtherNet/IP .....	194
6.2.4.2	What do you need for communication via EtherNet/IP? .....	195
6.2.4.3	Configuring communication via EtherNet/IP .....	195
6.2.4.4	Supported objects .....	196
6.2.4.5	Create generic I/O module .....	210
6.2.4.6	The converter as Ethernet node.....	210
6.2.5	Jogging.....	212
6.2.6	Switching over the drive control (command data set) .....	214
6.2.7	Selecting physical units.....	216
6.2.7.1	Motor standard .....	216
6.2.7.2	Unit system .....	216
6.2.7.3	Technological unit of the technology controller .....	217
6.2.8	Safe Torque Off (STO) safety function.....	218
6.2.8.1	Safe Torque Off (STO) safety function.....	218
6.2.8.2	Setting the feedback signal for Safe Torque Off .....	220
6.3	Pump control .....	222
6.3.1	Multi-pump control.....	222
6.3.1.1	Pump switch-in/switch-out.....	224
6.3.1.2	Stop mode.....	229
6.3.1.3	Pump switchover.....	232
6.3.1.4	Service mode .....	234
6.3.2	Frost protection .....	237
6.3.3	Condensation protection .....	238
6.3.4	Cavitation protection .....	240

6.3.5	Deragging.....	241
6.3.6	Pipe filling.....	243
6.4	Setpoints and setpoint processing .....	246
6.4.1	Setpoints .....	246
6.4.1.1	Analog input as setpoint source .....	247
6.4.1.2	Specifying the setpoint via the fieldbus .....	248
6.4.1.3	Motorized potentiometer as setpoint source .....	249
6.4.1.4	Fixed speed setpoint as setpoint source.....	252
6.4.2	Setpoint processing.....	257
6.4.2.1	Overview .....	257
6.4.2.2	Invert setpoint.....	258
6.4.2.3	Enable direction of rotation .....	259
6.4.2.4	Skip frequency bands and minimum speed .....	260
6.4.2.5	Speed limitation.....	263
6.4.2.6	Ramp-function generator .....	264
6.4.2.7	Dual ramp function .....	267
6.5	Technology controller.....	269
6.5.1	PID technology controller .....	269
6.5.1.1	Autotuning the PID technology controller.....	280
6.5.1.2	Adapting Kp and Tn .....	283
6.5.2	Free technology controllers.....	286
6.5.3	Cascade control .....	287
6.5.4	Real time clock (RTC) .....	292
6.5.5	Time switch (DTC) .....	294
6.6	Motor control .....	295
6.6.1	Reactor, filter and cable resistance at the converter output.....	295
6.6.2	V/f control .....	296
6.6.2.1	U/f control.....	296
6.6.2.2	Optimizing motor starting .....	301
6.6.2.3	U/f control with Standard Drive Control.....	306
6.6.2.4	Optimizing the motor start-up for application class Standard Drive Control.....	308
6.6.3	Encoderless vector control.....	310
6.6.3.1	Structure of vector control without encoder (sensorless).....	310
6.6.3.2	Optimizing the speed controller.....	315
6.6.4	Electrically braking the motor .....	317
6.6.4.1	DC braking .....	319
6.6.4.2	Compound braking.....	321
6.6.5	Pulse frequency wobbling .....	322
6.7	Drive protection .....	323
6.7.1	Overcurrent protection .....	323
6.7.2	Converter protection using temperature monitoring.....	324
6.7.3	Motor protection with temperature sensor.....	327
6.7.4	Motor protection by calculating the temperature .....	329
6.7.5	Motor and converter protection by limiting the voltage.....	331
6.7.6	Monitoring the driven load.....	332
6.7.6.1	Stall protection .....	334
6.7.6.2	No-load monitoring.....	334
6.7.6.3	Blocking protection.....	335
6.7.6.4	Torque monitoring .....	336
6.7.6.5	Blocking protection, leakage protection and dry-running protection .....	337



6.7.6.6	Rotation monitoring .....	339
6.8	Drive availability .....	340
6.8.1	Flying restart – switching on while the motor is running .....	340
6.8.2	Automatic restart .....	342
6.8.3	Kinetic buffering (Vdc min control) .....	345
6.8.4	Essential service mode .....	346
6.9	Energy saving .....	351
6.9.1	Efficiency optimization.....	351
6.9.2	Bypass .....	354
6.9.3	Hibernation mode .....	360
6.9.4	Line contactor control.....	366
6.9.5	Calculating the energy saving for fluid flow machines .....	368
6.10	Switchover between different settings.....	370
<b>7</b>	<b>Parameters .....</b>	<b>373</b>
7.1	Brief description of the parameters .....	373
7.2	Explanation of the detailed parameter list .....	374
7.3	Parameter list .....	376
7.4	ASCII table .....	757
<b>8</b>	<b>Saving the settings and series commissioning .....</b>	<b>759</b>
8.1	Memory card .....	760
8.1.1	Recommended memory cards .....	760
8.1.2	Saving setting on a memory card.....	760
8.1.2.1	Automatic backup.....	761
8.1.2.2	Manual backup.....	762
8.1.3	Transferring the setting from the memory card .....	762
8.1.3.1	Automatic transfer .....	762
8.1.3.2	Manually transferring.....	763
8.1.4	Safely remove the memory card .....	764
8.1.5	Message for a memory card that is not inserted .....	765
8.2	Operator panel .....	766
8.2.1	Backup using the operator panel .....	766
8.2.2	Transfer to the converter .....	766
8.3	Other ways to back up settings .....	768
8.4	Series commissioning .....	769
8.5	Write protection .....	770
8.6	Know-how protection.....	772
8.6.1	Extending the exception list for know-how protection .....	775
8.6.2	Activating and deactivating know-how protection .....	776
<b>9</b>	<b>Warnings, faults and system messages .....</b>	<b>777</b>
9.1	Operating states indicated on LEDs.....	778
9.2	System runtime .....	780
9.3	Identification & maintenance data (I&M) .....	781

9.4	Alarms, alarm buffer, and alarm history .....	782
9.5	Faults, alarm buffer and alarm history.....	785
9.6	List of fault codes and alarm codes.....	788
9.6.1	Overview of faults and alarms.....	788
9.6.2	Fault codes and alarm codes .....	788
<b>10</b>	<b>Corrective maintenance.....</b>	<b>863</b>
10.1	Replacing the converter .....	864
10.1.1	Overview of how to replace a converter.....	864
10.1.2	Replacing a converter with data backup .....	865
10.1.3	Replacing a converter without data backup .....	866
10.2	Replacing spare parts .....	868
10.2.1	Spare parts compatibility.....	868
10.2.2	Spare parts overview .....	868
10.2.3	Fan units .....	869
10.2.3.1	Replacing the fan unit, FSA ... FSC .....	871
10.2.3.2	Replacing the fan unit, FSD ... FSG.....	872
10.2.3.3	Replacing the fan unit, FSH/FSJ.....	873
10.2.3.4	Replacing the internal fan, FSH/FSJ only .....	874
10.2.4	Assemblies for FSH and FSJ .....	877
10.2.4.1	Replacing the power supply board.....	877
10.2.4.2	Replacing the free programmable interface (FPI).....	880
10.2.4.3	Replacing the current sensor .....	883
10.3	Firmware upgrade and downgrade .....	887
10.3.1	Preparing the memory card.....	888
10.3.2	Upgrading the firmware.....	889
10.3.3	Firmware downgrade .....	891
10.3.4	Correcting an unsuccessful firmware upgrade or downgrade.....	893
10.4	Reduced acceptance test after component replacement and firmware change .....	894
<b>11</b>	<b>Technical data .....</b>	<b>895</b>
11.1	Technical data of inputs and outputs .....	895
11.2	Load cycles and overload capability .....	898
11.3	General converter technical data .....	900
11.4	Technical data dependent on the power .....	903
11.5	Derating data.....	907
11.5.1	Current derating as a function of the installation altitude .....	907
11.5.2	Current derating as a function of the ambient temperature.....	908
11.5.3	Current derating as a function of the line voltage.....	908
11.5.4	Current derating as a function of the pulse frequency .....	910
11.6	Low frequency performance.....	912
11.7	Data regarding the power loss in partial load operation.....	913
11.8	Electromagnetic compability of the converter .....	914
11.8.1	Overview .....	914
11.8.2	Operation in the Second EMC environment.....	915
11.8.2.1	High-frequency interference emissions EMC category C3 .....	915

---

11.8.2.2	High-frequency interference emissions EMC category C2 .....	916
11.8.2.3	Current harmonics.....	916
11.8.3	Operation in the First EMC environment.....	917
11.8.3.1	General information.....	917
11.8.3.2	High-frequency, conducted and radiated interference emissions, EMC Category C2 .....	917
11.8.3.3	High-frequency, conducted interference emissions, EMC Category C1 .....	918
11.8.3.4	Current harmonics of individual devices .....	918
11.8.3.5	Harmonics at the power supply connection point acc. to IEC 6100-2-2.....	920
11.8.3.6	Harmonics at the power supply connection point acc. to IEEE 519.....	920
11.9	Protecting persons from electromagnetic fields .....	922
<b>A</b>	<b>Appendix.....</b>	<b>925</b>
A.1	Handling the BOP-2 operator panel .....	925
A.1.1	Changing settings using BOP-2 .....	926
A.1.2	Changing indexed parameters .....	927
A.1.3	Directly entering the parameter number and value .....	928
A.1.4	A parameter cannot be changed.....	929
A.2	Interconnecting signals in the converter.....	930
A.3	Manuals and technical support .....	932
A.3.1	Overview of the manuals.....	932
A.3.2	Configuring support.....	933
A.3.3	Product Support .....	934
	<b>Index.....</b>	<b>935</b>



# Fundamental safety instructions

## 1.1 General safety instructions



### **⚠ WARNING**

#### **Electric shock and danger to life due to other energy sources**

Touching live components can result in death or severe injury.

- Only work on electrical devices when you are qualified for this job.
- Always observe the country-specific safety rules.

Generally, the following six steps apply when establishing safety:

1. Prepare for disconnection. Notify all those who will be affected by the procedure.
2. Isolate the drive system from the power supply and take measures to prevent it being switched back on again.
3. Wait until the discharge time specified on the warning labels has elapsed.
4. Check that there is no voltage between any of the power connections, and between any of the power connections and the protective conductor connection.
5. Check whether the existing auxiliary supply circuits are de-energized.
6. Ensure that the motors cannot move.
7. Identify all other dangerous energy sources, e.g. compressed air, hydraulic systems, or water. Switch the energy sources to a safe state.
8. Check that the correct drive system is completely locked.

After you have completed the work, restore the operational readiness in the inverse sequence.



### **⚠ WARNING**

#### **Risk of electric shock and fire from supply networks with an excessively high impedance**

Excessively low short-circuit currents can lead to the protective devices not tripping or tripping too late, and thus causing electric shock or a fire.

- In the case of a conductor-conductor or conductor-ground short-circuit, ensure that the short-circuit current at the point where the inverter is connected to the line supply at least meets the minimum requirements for the response of the protective device used.
- You must use an additional residual-current device (RCD) if a conductor-ground short circuit does not reach the short-circuit current required for the protective device to respond. The required short-circuit current can be too low, especially for TT supply systems.



**⚠ WARNING**

**Risk of electric shock and fire from supply networks with an excessively low impedance**

Excessively high short-circuit currents can lead to the protective devices not being able to interrupt these short-circuit currents and being destroyed, and thus causing electric shock or a fire.

- Ensure that the prospective short-circuit current at the line terminal of the inverter does not exceed the breaking capacity (SCCR or I<sub>cc</sub>) of the protective device used.



**⚠ WARNING**

**Electric shock if there is no ground connection**

For missing or incorrectly implemented protective conductor connection for devices with protection class I, high voltages can be present at open, exposed parts, which when touched, can result in death or severe injury.

- Ground the device in compliance with the applicable regulations.



**⚠ WARNING**

**Electric shock due to connection to an unsuitable power supply**

When equipment is connected to an unsuitable power supply, exposed components may carry a hazardous voltage. Contact with hazardous voltage can result in severe injury or death.

- Only use power supplies that provide SELV (Safety Extra Low Voltage) or PELV- (Protective Extra Low Voltage) output voltages for all connections and terminals of the electronics modules.



**⚠ WARNING**

**Electric shock due to equipment damage**

Improper handling may cause damage to equipment. For damaged devices, hazardous voltages can be present at the enclosure or at exposed components; if touched, this can result in death or severe injury.

- Ensure compliance with the limit values specified in the technical data during transport, storage and operation.
- Do not use any damaged devices.



**⚠ WARNING**

**Electric shock due to unconnected cable shield**

Hazardous touch voltages can occur through capacitive cross-coupling due to unconnected cable shields.

- As a minimum, connect cable shields and the conductors of power cables that are not used (e.g. brake cores) at one end at the grounded housing potential.



**⚠ WARNING**

**Arcing when a plug connection is opened during operation**

Opening a plug connection when a system is operation can result in arcing that may cause serious injury or death.

- Only open plug connections when the equipment is in a voltage-free state, unless it has been explicitly stated that they can be opened in operation.



**⚠ WARNING**

**Electric shock due to residual charges in power components**

Because of the capacitors, a hazardous voltage is present for up to 5 minutes after the power supply has been switched off. Contact with live parts can result in death or serious injury.

- Wait for 5 minutes before you check that the unit really is in a no-voltage condition and start work.

**NOTICE**

**Property damage due to loose power connections**

Insufficient tightening torques or vibration can result in loose power connections. This can result in damage due to fire, device defects or malfunctions.

- Tighten all power connections to the prescribed torque.
- Check all power connections at regular intervals, particularly after equipment has been transported.

**⚠ WARNING**

**Spread of fire from built-in devices**

In the event of fire outbreak, the enclosures of built-in devices cannot prevent the escape of fire and smoke. This can result in serious personal injury or property damage.

- Install built-in units in a suitable metal cabinet in such a way that personnel are protected against fire and smoke, or take other appropriate measures to protect personnel.
- Ensure that smoke can only escape via controlled and monitored paths.

 **WARNING**

**Active implant malfunctions due to electromagnetic fields**

Inverters generate electromagnetic fields (EMF) in operation. Electromagnetic fields may interfere with active implants, e.g. pacemakers. People with active implants in the immediate vicinity of an inverter are at risk.

- As the operator of an EMF-emitting installation, assess the individual risks of persons with active implants.
- Observe the data on EMF emission provided in the product documentation.

 **WARNING**

**Unexpected movement of machines caused by radio devices or mobile phones**

When radio devices or mobile phones with a transmission power  $> 1 \text{ W}$  are used in the immediate vicinity of components, they may cause the equipment to malfunction. Malfunctions may impair the functional safety of machines and can therefore put people in danger or lead to property damage.

- If you come closer than around 2 m to such components, switch off any radios or mobile phones.
- Use the "SIEMENS Industry Online Support app" only on equipment that has already been switched off.

**NOTICE**

**Damage to motor insulation due to excessive voltages**

When operated on systems with grounded line conductor or in the event of a ground fault in the IT system, the motor insulation can be damaged by the higher voltage to ground. If you use motors that have insulation that is not designed for operation with grounded line conductors, you must perform the following measures:

- IT system: Use a ground fault monitor and eliminate the fault as quickly as possible.
- TN or TT systems with grounded line conductor: Use an isolating transformer on the line side.

 **WARNING**

**Fire due to inadequate ventilation clearances**

Inadequate ventilation clearances can cause overheating of components with subsequent fire and smoke. This can cause severe injury or even death. This can also result in increased downtime and reduced service lives for devices/systems.

- Ensure compliance with the specified minimum clearance as ventilation clearance for the respective component.



**NOTICE****Overheating due to inadmissible mounting position**

The device may overheat and therefore be damaged if mounted in an inadmissible position.

- Only operate the device in admissible mounting positions.

 **WARNING****Unrecognized dangers due to missing or illegible warning labels**

Dangers might not be recognized if warning labels are missing or illegible. Unrecognized dangers may cause accidents resulting in serious injury or death.

- Check that the warning labels are complete based on the documentation.
- Attach any missing warning labels to the components, where necessary in the national language.
- Replace illegible warning labels.

**NOTICE****Device damage caused by incorrect voltage/insulation tests**

Incorrect voltage/insulation tests can damage the device.

- Before carrying out a voltage/insulation check of the system/machine, disconnect the devices as all converters and motors have been subject to a high voltage test by the manufacturer, and therefore it is not necessary to perform an additional test within the system/machine.

 **WARNING****Unexpected movement of machines caused by inactive safety functions**

Inactive or non-adapted safety functions can trigger unexpected machine movements that may result in serious injury or death.

- Observe the information in the appropriate product documentation before commissioning.
- Carry out a safety inspection for functions relevant to safety on the entire system, including all safety-related components.
- Ensure that the safety functions used in your drives and automation tasks are adjusted and activated through appropriate parameterizing.
- Perform a function test.
- Only put your plant into live operation once you have guaranteed that the functions relevant to safety are running correctly.

---

**Note**

**Important safety notices for Safety Integrated functions**

If you want to use Safety Integrated functions, you must observe the safety notices in the Safety Integrated manuals.

---

 **WARNING**

**Malfunctions of the machine as a result of incorrect or changed parameter settings**

As a result of incorrect or changed parameterization, machines can malfunction, which in turn can lead to injuries or death.

- Protect the parameterization against unauthorized access.
- Handle possible malfunctions by taking suitable measures, e.g. emergency stop or emergency off.

## 1.2 Equipment damage due to electric fields or electrostatic discharge

Electrostatic sensitive devices (ESD) are individual components, integrated circuits, modules or devices that may be damaged by either electric fields or electrostatic discharge.



### NOTICE

#### Equipment damage due to electric fields or electrostatic discharge

Electric fields or electrostatic discharge can cause malfunctions through damaged individual components, integrated circuits, modules or devices.

- Only pack, store, transport and send electronic components, modules or devices in their original packaging or in other suitable materials, e.g. conductive foam rubber or aluminum foil.
- Only touch components, modules and devices when you are grounded by one of the following methods:
  - Wearing an ESD wrist strap
  - Wearing ESD shoes or ESD grounding straps in ESD areas with conductive flooring
- Only place electronic components, modules or devices on conductive surfaces (table with ESD surface, conductive ESD foam, ESD packaging, ESD transport container).

## **1.3 Warranty and liability for application examples**

Application examples are not binding and do not claim to be complete regarding configuration, equipment or any eventuality which may arise. Application examples do not represent specific customer solutions, but are only intended to provide support for typical tasks.

As the user you yourself are responsible for ensuring that the products described are operated correctly. Application examples do not relieve you of your responsibility for safe handling when using, installing, operating and maintaining the equipment.

## 1.4 Industrial security

---

### Note

#### Industrial security

Siemens provides products and solutions with industrial security functions that support the secure operation of plants, systems, machines and networks.

In order to protect plants, systems, machines and networks against cyber threats, it is necessary to implement – and continuously maintain – a holistic, state-of-the-art industrial security concept. Products and solutions from Siemens constitute one element of such a concept.

Customers are responsible for preventing unauthorized access to their plants, systems, machines and networks. Such systems, machines and components should only be connected to an enterprise network or the Internet if and to the extent such a connection is necessary and only when appropriate security measures (e.g. using firewalls and/or network segmentation) are in place.

For additional information on industrial security measures that can be implemented, please visit:

Industrial security (<https://www.siemens.com/industrialsecurity>)

Siemens' products and solutions undergo continuous development to make them more secure. Siemens strongly recommends that product updates are applied as soon as they become available, and that only the latest product versions are used. Use of product versions that are no longer supported, and failure to apply the latest updates may increase customer's exposure to cyber threats.

To stay informed about product updates, subscribe to the Siemens Industrial Security RSS Feed at:

Industrial security (<https://www.siemens.com/industrialsecurity>)

---

Further information is provided on the Internet:

Industrial Security Configuration Manual (<https://support.industry.siemens.com/cs/ww/en/view/108862708>)



**WARNING**

**Unsafe operating states resulting from software manipulation**

Software manipulations, e.g. viruses, Trojans, or worms, can cause unsafe operating states in your system that may lead to death, serious injury, and property damage.

- Keep the software up to date.
- Incorporate the automation and drive components into a holistic, state-of-the-art industrial security concept for the installation or machine.
- Make sure that you include all installed products into the holistic industrial security concept.
- Protect files stored on exchangeable storage media from malicious software by with suitable protection measures, e.g. virus scanners.
- On completion of commissioning, check all security-related settings.
- Protect the drive against unauthorized changes by activating the "Know-how protection" converter function.

## 1.5 Residual risks of power drive systems

When assessing the machine- or system-related risk in accordance with the respective local regulations (e.g., EC Machinery Directive), the machine manufacturer or system installer must take into account the following residual risks emanating from the control and drive components of a drive system:

1. Unintentional movements of driven machine or system components during commissioning, operation, maintenance, and repairs caused by, for example,
  - Hardware and/or software errors in the sensors, control system, actuators, and cables and connections
  - Response times of the control system and of the drive
  - Operation and/or environmental conditions outside the specification
  - Condensation/conductive contamination
  - Parameterization, programming, cabling, and installation errors
  - Use of wireless devices/mobile phones in the immediate vicinity of electronic components
  - External influences/damage
  - X-ray, ionizing radiation and cosmic radiation
2. Unusually high temperatures, including open flames, as well as emissions of light, noise, particles, gases, etc., can occur inside and outside the components under fault conditions caused by, for example:
  - Component failure
  - Software errors
  - Operation and/or environmental conditions outside the specification
  - External influences/damage
3. Hazardous shock voltages caused by, for example:
  - Component failure
  - Influence during electrostatic charging
  - Induction of voltages in moving motors
  - Operation and/or environmental conditions outside the specification
  - Condensation/conductive contamination
  - External influences/damage
4. Electrical, magnetic and electromagnetic fields generated in operation that can pose a risk to people with a pacemaker, implants or metal replacement joints, etc., if they are too close
5. Release of environmental pollutants or emissions as a result of improper operation of the system and/or failure to dispose of components safely and correctly
6. Influence of network-connected communication systems, e.g. ripple-control transmitters or data communication via the network

For more information about the residual risks of the drive system components, see the relevant sections in the technical user documentation.





## Description

### 2.1 About the Manual

#### Who requires the operating instructions and what for?

These operating instructions primarily address fitters, commissioning engineers and machine operators. The operating instructions describe the devices and device components and enable the target groups being addressed to install, connect-up, set, and commission the converters safely and in the correct manner.

#### What is described in the operating instructions?

These operating instructions provide a summary of all of the information required to operate the converter under normal, safe conditions.

The information provided in the operating instructions has been compiled in such a way that it is sufficient for all standard applications and enables drives to be commissioned as efficiently as possible. Where it appears useful, additional information for entry level personnel has been added.

The operating instructions also contain information about special applications. Since it is assumed that readers already have a sound technical knowledge of how to configure and parameterize these applications, the relevant information is summarized accordingly. This relates, e.g. to operation with fieldbus systems.

#### What is the meaning of the symbols in the manual?



 Reference to further information in the manual

 Download from the Internet

 DVD that can be ordered

End of a handling instruction.



  Examples of converter function symbols

## 2.2 About the converter

### Use for the intended purpose

The converter described in this manual is a device to control a three-phase motor. The converter is designed for installation in electrical installations or machines.

It has been approved for industrial and commercial use on industrial networks. Additional measures have to be taken when connected to public grids.

The technical specifications and information about connection conditions are indicated on the rating plate and in the operating instructions.

### Use of third-party products

This document contains recommendations relating to third-party products. Siemens accepts the fundamental suitability of these third-party products.

You can use equivalent products from other manufacturers.

Siemens does not accept any warranty for the properties of third-party products.

### Use of OpenSSL

This product contains software developed in the OpenSSL project for use within the OpenSSL toolkit.

This product contains cryptographic software created by Eric Young.

This product contains software developed by Eric Young.

Further information is provided on the Internet:

 OpenSSL (<https://www.openssl.org/>)

 Cryptsoft (<mailto:eay@cryptsoft.com>)

## 2.3 Scope of delivery

The delivery comprises at least the following components:

- A ready-to-run converter with loaded firmware. Each converter comprises a Power Module and a Control Unit.

Options for upgrading and downgrading the firmware can be found on the Internet:

 Firmware (<https://support.industry.siemens.com/cs/ww/en/view/67364620>)

- One set of connectors for connecting the I/O control terminals.
- One set of shield connection kit for the Power Module (available for FSA to FSG only).
- One set of shield connection kit for the Control Unit (available for FSD to FSG only).
- Compact Installation Instructions in German and English.
- A printed full-size drill pattern (available for FSD to FSG only), which allows the easy drilling of the necessary mounting holes.
- The converter contains open-source software (OSS). The OSS license terms are saved in the converter.

Technical data

3-phase 380 V AC to 480 V AC (article number: 6SL32...)

380 V ... 480 V	Rated output power - kW (hp)	Rated output current kW - A (hp - A)	Article number	
Frame size	Based on a low overload		Without filter	With filter
FSA	0.75 (1)	2.2 (2.1)	6SL32□0-□YE10-0UF0	6SL32□0-□YE10-0 A F0
	1.1 (1.5)	3.1 (3.0)	6SL32□0-□YE12-0UF0	6SL32□0-□YE12-0 A F0
	1.5 (2)	4.1 (3.4)	6SL32□0-□YE14-0UF0	6SL32□0-□YE14-0 A F0
	2.2 (3)	5.9 (4.8)	6SL32□0-□YE16-0UF0	6SL32□0-□YE16-0 A F0
	3 (4)	7.7 (6.2)	6SL32□0-□YE18-0UF0	6SL32□0-□YE18-0 A F0
FSB	4 (5)	10.2 (7.6)	6SL32□0-□YE20-0UF0	6SL32□0-□YE20-0 A F0
	5.5 (7.5)	13.2 (11)	6SL32□0-□YE22-0UF0	6SL32□0-□YE22-0 A F0
	7.5 (10)	18 (14)	6SL32□0-□YE24-0UF0	6SL32□0-□YE24-0 A F0
FSC	11 (15)	26 (21)	6SL32□0-□YE26-0UF0	6SL32□0-□YE26-0 A F0
	15 (20)	32 (27)	6SL32□0-□YE28-0UF0	6SL32□0-□YE28-0 A F0
FSD	18.5 (25)	38 (34)	6SL32□0-□YE30-0UF0	6SL32□0-□YE30-0 A F0
	22 (30)	45 (40)	6SL32□0-□YE32-0UF0	6SL32□0-□YE32-0 A F0
	30 (40)	60 (52)	6SL32□0-□YE34-0UF0	6SL32□0-□YE34-0 A F0
	37 (50)	75 (65)	6SL32□0-□YE36-0UF0	6SL32□0-□YE36-0 A F0
FSE	45 (60)	90 (77)	6SL32□0-□YE38-0UF0	6SL32□0-□YE38-0 A F0
	55 (75)	110 (96)	6SL32□0-□YE40-0UF0	6SL32□0-□YE40-0 A F0
FSF	75 (100)	145 (124)	6SL32□0-□YE42-0UF0	6SL32□0-□YE42-0 A F0
	90 (125)	178 (156)	6SL32□0-□YE44-0UF0	6SL32□0-□YE44-0 A F0
	110 (150)	205 (180)	6SL32□0-□YE46-0UF0	6SL32□0-□YE46-0 A F0
	132 (200)	250 (240)	6SL32□0-□YE48-0UF0	6SL32□0-□YE48-0 A F0
FSG	160 (250)	302 (302)	-	6SL32□0-□YE50-0□F0
	200 (300)	370 (361)	-	6SL32□0-□YE52-0□F0
	250 (400)	477 (477)	-	6SL32□0-□YE54-0□F0
FSH	315 (n/a)	570 (477)	-	6SL32 2 0-□YE56-0 C F0
	355 (450)	640 (515)	-	6SL32 2 0-□YE58-0 C F0
	400 (500)	720 (590)	-	6SL32 2 0-□YE60-0 C F0
FSJ	450 (n/a)	820 (663)	-	6SL32 2 0-□YE62-0 C F0
	500 (600)	890 (724)	-	6SL32 2 0-□YE64-0 C F0
	560 (700)	1000 (830)	-	6SL32 2 0-□YE66-0 C F0
Environment class 3C2			2	2
Environment class 3C3			3	3
Without operator panel			1	1
With Operator Panel BOP-2			2	2
With Operator Panel IOP-2			3	3
Filter C2				A
Filter C3				C

## 3-phase 500 V AC to 690 V AC (article number: 6SL32...)

500 V ... 690 V *	Rated output power - kW (hp)	Rated output current kW - A (hp - A)	Article number	
Frame size	Based on a low overload		Without filter	With filter
FSD	3 (3)	5 (5)	6SL32□0-□YH18-0UF0	6SL32□0-□YH18-0AF0
	4 (5)	6.3 (6.3)	6SL32□0-□YH20-0UF0	6SL32□0-□YH20-0AF0
	5.5 (7.5)	9 (9)	6SL32□0-□YH22-0UF0	6SL32□0-□YH22-0AF0
	7.5 (10)	11 (11)	6SL32□0-□YH24-0UF0	6SL32□0-□YH24-0AF0
	11 (n/a)	14 (14)	6SL32□0-□YH26-0UF0	6SL32□0-□YH26-0AF0
	15 (15)	19 (19)	6SL32□0-□YH28-0UF0	6SL32□0-□YH28-0AF0
	18.5 (20)	23 (23)	6SL32□0-□YH30-0UF0	6SL32□0-□YH30-0AF0
	22 (25)	27 (27)	6SL32□0-□YH32-0UF0	6SL32□0-□YH32-0AF0
	30 (30)	35 (35)	6SL32□0-□YH34-0UF0	6SL32□0-□YH34-0AF0
	37 (40)	42 (42)	6SL32□0-□YH36-0UF0	6SL32□0-□YH36-0AF0
FSE	45 (50)	52 (52)	6SL32□0-□YH38-0UF0	6SL32□0-□YH38-0AF0
	55 (60)	62 (62)	6SL32□0-□YH40-0UF0	6SL32□0-□YH40-0AF0
FSF	75 (75)	80 (80)	6SL32□0-□YH42-0UF0	6SL32□0-□YH42-0CF0
	90 (100)	100 (100)	6SL32□0-□YH44-0UF0	6SL32□0-□YH44-0CF0
	110 (125)	125 (125)	6SL32□0-□YH46-0UF0	6SL32□0-□YH46-0CF0
	132 (150)	144 (144)	6SL32□0-□YH48-0UF0	6SL32□0-□YH48-0CF0
FSG	160 (n/a)	171 (171)	-	6SL32□0-□YH50-0CF0
	200 (200)	208 (208)	-	6SL32□0-□YH52-0CF0
	250 (250)	250 (250)	-	6SL32□0-□YH54-0CF0
FSH	315 (350)	330 (345)	-	6SL32 2 0-□YH56-0CF0
	355 (400)	385 (388)	-	6SL32 2 0-□YH58-0CF0
	400 (450)	420 (432)	-	6SL32 2 0-□YH60-0CF0
	450 (500)	470 (487)	-	6SL32 2 0-□YH62-0CF0
FSJ	500 (n/a)	520 (546)	-	6SL32 2 0-□YH64-0CF0
	560 (600)	580 (610)	-	6SL32 2 0-□YH66-0CF0
	630 (700)	650 (679)	-	6SL32 2 0-□YH68-0CF0
Environment class 3C2			2	2
Environment class 3C3			3	3
Without operator panel			1	1
With Operator Panel BOP-2			2	2
With Operator Panel IOP-2			3	3
Filter C2				A
Filter C3				C

\* For systems according to UL: 500 V ... 600 V

Rating plate

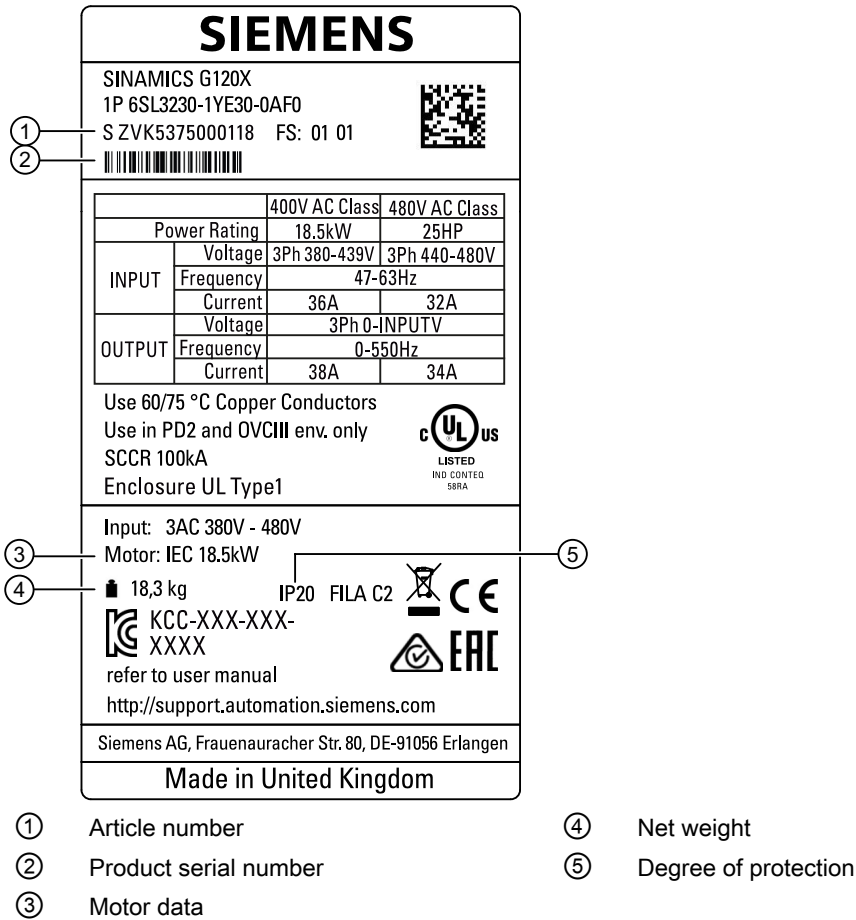

Figure 2-1 Example for a rating plate

You will find the rating plate at the side of the converter.

## 2.4 Directives and standards

### Relevant directives and standards

The following directives and standards are relevant for the converters:



#### European Low Voltage Directive

The converters fulfill the requirements stipulated in the Low-Voltage Directive 2014/35/EU, if they are covered by the application area of this directive.

#### European Machinery Directive

The converters fulfill the requirements stipulated in the Machinery Directive 2006/42/EC, if they are covered by the application area of this directive.

However, the use of the converters in a typical machine application has been fully assessed for compliance with the main regulations in this directive concerning health and safety.

#### Directive 2011/65/EU

The converter fulfills the requirements of Directive 2011/65/EU relating to the restriction of the use of certain hazardous substances in electrical and electronic devices (RoHS).

#### European EMC Directive

The compliance of the converter with the regulations of the Directive 2014/30/EU has been demonstrated by full compliance with the IEC/EN 61800-3.



#### EMC requirements for South Korea

The converters with the KC marking on the rating plate satisfy the EMC requirements for South Korea.



#### Underwriters Laboratories (North American market)

Converters provided with one of the test symbols displayed fulfill the requirements stipulated for the North American market as a component of drive applications, and are appropriately listed.



#### Eurasian conformity

The converter complies with the requirements of the Russia/Belarus/Kazakhstan customs union (EAC).



#### Australia and New Zealand (RCM formerly C-Tick)

The converters showing the test symbols fulfill the EMC requirements for Australia and New Zealand.





#### Immunity to voltage drop of semiconductor process equipment.

The converters comply with the requirements of standard SEMI F47-0706.

### Quality systems

Siemens AG employs a quality management system that meets the requirements of ISO 9001 and ISO 14001.

### Certificates for download

-  EC Declaration of Conformity: (<https://support.industry.siemens.com/cs/ww/de/view/58275445>)
-  Certificates for the relevant directives, prototype test certificates, manufacturers declarations and test certificates for functions relating to functional safety ("Safety Integrated"): (<http://support.automation.siemens.com/WW/view/en/22339653/134200>)
-  Certificates for products that were certified by UL: (<http://database.ul.com/cgi-bin/XYV/template/LISEXT/1FRAME/index.html>)
-  Certificates for products that were certified by TÜV SÜD: ([https://www.tuev-sued.de/industrie\\_konsumprodukte/zertifikatsdatenbank](https://www.tuev-sued.de/industrie_konsumprodukte/zertifikatsdatenbank))

### Standards that are not relevant



#### China Compulsory Certification

The converters do not fall in the area of validity of the China Compulsory Certification (CCC).



## 2.5 Device disposal

### Recycling and disposal



For environmentally-friendly recycling and disposal of your old device, please contact a company certified for the disposal of waste electrical and electronic equipment, and dispose of the old device as prescribed in the respective country of use.

## 2.6 Optional components

The following optional components are available so that you can adapt the converter to different applications and ambient conditions:

- External line filter (Page 32)
- Line reactor (Page 33)
- Output reactor (Page 35)
- Sine-wave filter (Page 36)
- dv/dt filter plus VPL (Page 38)
- Push-through mounting kit (Page 39)
- IP21 top cover (Page 42)
- Operator panel (Page 44)
- SINAMICS G120 Smart Access (Page 44)

### Further information

Further information about the technical specifications and installing of these optional components is described in the documentation provided.

### 2.6.1 External line filter

With a line filter, the converter achieves a higher radio interference class. The converters of frame sizes FSA to FSF are available with and without integrated line filter. The converters of frame sizes FSG to FSJ are available with integrated line filter only. External line filters are available as optional components for the converter FSH and FSJ.

#### NOTICE

##### Overloading the line filter when connected to line supplies that are not permissible

The line filter is only suitable for operation on TN or TT line supplies with a grounded neutral point. If operated on other line supplies, the line filter will be thermally overloaded and will be damaged.

- For converters equipped with line filter, only connect to TN or TT line supplies with a grounded neutral point.

### Article number

Converter frame size	Rated power (kW)	Line filter
400 V converters		
FSA	0.75 ... 3	6SL3203-0BE17-7BA0
FSB	4 ... 7.5	6SL3203-0BE21-8BA0

Converter frame size	Rated power (kW)	Line filter
FSC	11 ... 15	6SL3203-0BE23-8BA0
FSD	18.5 ... 22	6SL3203-0BE23-8BA0
	30 ... 37	6SL3203-0BE27-5BA0
FSE	45 ... 55	6SL3203-0BE31-1BA0
FSF	75 ... 110	6SL3203-0BE31-8BA0
	132	-
FSG	160 ... 250	-
FSH	315 ... 400	6SL3760-0MR00-0AA0
FSJ	450 ... 560	
690 V converters		
FSH	315 ... 450	6SL3760-0MS00-0AA0
FSJ	500 ... 630	

## 2.6.2 Line reactor

### Note

Line reactors are not required for converters of frame sizes FSA to FSG.

A line reactor is needed for high short-circuit power levels, partly to protect the actual converter against excessive harmonic currents, and thus against overload, and partly to limit line harmonics to the permitted values. The harmonic currents are limited by the total inductance comprising the line reactor and mains supply cable inductance. Line reactors can be omitted if the mains supply cable inductance is increased sufficiently, i.e., the value of  $R_{SC}$  must be sufficiently small.

$R_{SC}$  = Relative Short-Circuit power: ratio of short-circuit power  $S_{k,Line}$  at the supply connection point to the fundamental apparent power  $S_{inv}$  of the connected converters (to IEC 60146-1-1).

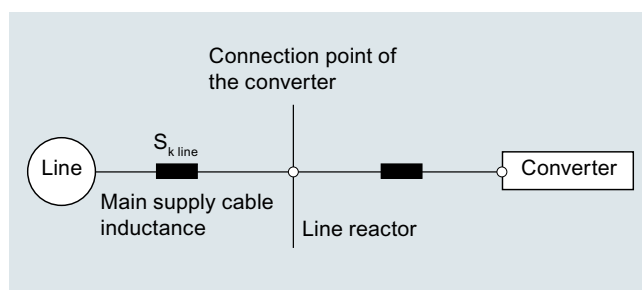

### Requirements for line reactors

Rated power of converter (kW)	Line reactor can be omitted for $R_{SC}$	Line reactor is required for $R_{SC}$
315 ... 500	$\leq 33$	$> 33$
$> 500$	$\leq 20$	$> 20$

2.6 Optional components

It is recommended that a line reactor is always connected on the line side of the converter, as in practice, it is often not known on which supply configuration individual converters are to be operated, i.e. which supply short-circuit power is present at the converter connection point.

A line reactor can only be dispensed with when the value for  $R_{SC}$  is less than that in the above table. This is the case, when the converter, as shown in the following figure, is connected to the line through a transformer with the appropriate rating.

**Note**

A line reactor is always needed if a line filter is used.

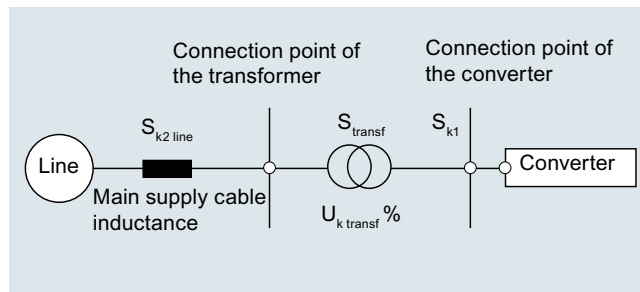

In this case, the line short-circuit power  $S_{k1}$  at the connection point of the converter is approximately:

$$S_{k1} = S_{transf} / (U_{k\ transf} + S_{transf} / S_{k2\ line})$$

$S_{transf}$  = Transformer rated power  
 $S_{k2\ line}$  = Short-circuit power of the higher-level voltage level  
 $U_{k\ transf}$  = Relative short-circuit voltage

**Article number**

Converter frame size	Rated power (kW)	Line reactor
400 V converters		
FSH	315	6SL3000-0CE36-3AA0
	355 ... 400	6SL3000-0CE37-7AA0
FSJ	450	6SL3000-0CE38-7AA0
	500 ... 560	6SL3000-0CE41-0AA0
690 V converters		
FSH	315 ... 400	6SL3000-0CH34-8AA0
	450	6SL3000-0CH36-0AA0
FSJ	500	
	560 ... 630	6SL3000-0CH38-4AA0

### 2.6.3 Output reactor

The output reactor reduces the voltage rate of rise and dampens transient voltage peak at the converter output, and enable longer motor cables to be connected.

 Maximum permissible motor cable length (Page 78)

#### NOTICE

##### Damage to the output reactor by exceeding the maximum pulse frequency

The maximum permissible pulse frequency when using the output reactor is 4 kHz. The output reactor can be damaged if the pulse frequency is exceeded.

- When using an output reactor, the pulse frequency of the converter must not exceed 4 kHz.

#### NOTICE

##### Damage to the output reactor if it is not activated during commissioning

The output reactor may be damaged if it is not activated during commissioning.

- Activate the output reactor during commissioning via the parameter specified by the converter manufacturer.
- Activate the output reactor during commissioning according to the electric specifications.

#### Note

Output reactors are available as optional components for 400 V converters, FSD ... FSH and FSJ as well as 690 V converters, FSH/FSJ only.

#### Article number

Converter frame size	Rated power (kW)	Output reactor
400 V converters		
FSD	18.5	6SL3202-0AE23-8CA0
	22 ... 37	6SE6400-3TC07-5ED0
FSE	45 ... 55	6SE6400-3TC14-5FD0
FSF	75 ... 90	
	110	6SL3000-2BE32-1AA0
	132	6SL3000-2BE32-6AA0
FSG	160	6SL3000-2BE33-2AA0
	200	6SL3000-2BE33-8AA0
	250	6SL3000-2BE35-0AA0
FSH	315	6SL3000-2AE36-1AA0
	355 ... 400	6SL3000-2AE38-4AA0
FSJ	450 ... 500	6SL3000-2AE41-0AA0
	560	6SL3000-2AE41-4AA0
690 V converters		

Converter frame size	Rated power (kW)	Output reactor
FSD	3 ... 18.5	JTA:TEU2532-0FP00-4EA0
	22 ... 37	JTA:TEU9932-0FP00-4EA0
FSE	45 ... 55	JTA:TEU9932-0FS00-0EA0
FSF	75 ... 90	JTA:TEU9932-1FC00-1BA0
	110 ... 132	JTA:TEU9932-0FV00-1BA0
FSG	160 ... 250	JTA:TEU4732-0FA00-0BA0
FSH	315 ... 355	6SL3000-2AH34-7AA0
	400	6SL3000-2AH35-8AA0
	450	6SL3000-2AH38-1AA0
FSJ	500 ... 630	

## 2.6.4 Sine-wave filter

The sine-wave filter limits the voltage gradient and the capacitive recharging currents which generally occur in converter operation. Therefore, when a sine-wave filter is used, longer screened motor cables are possible and the motor lifetime reaches the same values which are achieved when the motor is connected directly to the mains.

 Maximum permissible motor cable length (Page 78)

When using sine-wave filters, observe the following restrictions:

- For rated power up to 90 kW, the pulse frequency should not exceed 8 kHz; for rated power above 90 kW, the pulse frequency should be 4 kHz.
- The maximum permissible output frequency is 150 Hz.

### Note

Sine-wave filters are available as optional components for 400 V converters of frame sizes FSD to FSG.

## Article number

Converter frame size	Rated power (kW)	Sine-wave filter
400 V converters		
FSD	18.5 ... 22	6SL3202-0AE24-6SA0
	30	6SL3202-0AE26-2SA0
	37	6SL3202-0AE28-8SA0
FSE	45	
	55	6SL3202-0AE31-5SA0
FSF	75	
	90	6SL3202-0AE31-8SA0
	110 ... 132	6SL3000-2CE32-3AA0

Converter frame size	Rated power (kW)	Sine-wave filter
FSG	160	6SL3000-2CE32-8AA0
	200	6SL3000-2CE33-3AA0
	250	6SL3000-2CE34-1AA0

### Special restrictions for converter FSG

When connecting 400 V converter FSG with sine-wave filters, set parameters as follows:

Parameter	6SL3000-2CE32-8AA0	6SL3000-2CE33-3AA0	6SL3000-2CE34-1AA0
p0230	4	4	4
p0233 [mH]	0.25	0.2	0.15
p0234 [ $\mu$ F]	28.2	42.3	56.4
p1082 [rpm]	150*60/r0313	150*60/r0313	150*60/r0313
p1800 [kHz]	4	4	4

For converter FSG with sine-wave filter, operation is only permissible in the vector control mode. It is not permissible for U/f mode to be used.

### 2.6.5 Line harmonics filter

The line harmonics filters reshape the distorted current back to the desired sinusoidal waveform. With the line harmonics filters, the converter fulfills the IEEE 519 standards.

If you use a line harmonics filter, you do not need a line reactor or a line filter.

When using the line harmonics filter, observe the following restrictions:

- The permissible line voltage is 380 V ... 415 V 3 AC  $\pm$ 10 %.
- The operating frequency is 50 Hz.

For technical details refer to the following link:

 Line harmonics filter (<https://www.schaffner.com/products/download/product/datasheet/fn-3440-ecosine-50hz-passive-harmonic-filters/>)

### Article number

400 V Converter frame size	Rated power (kW)	Line harmonics filter
FSB	5.5	UAC:FN34406112E2XXJRX
	7.5	UAC:FN34408112E2XXJRX
FSC	11	UAC:FN344011113E2FAJRX
	15	UAC:FN344015113E2FAJRX

400 V Converter frame size	Rated power (kW)	Line harmonics filter
FSD	18.5	UAC:FN344019113E2FAJRX
	22	UAC:FN344022115E2FAJRX
	30	UAC:FN344030115E2FAJRX
	37	UAC:FN344037115E2FAJRX
FSE	45	UAC:FN344045115E2FAJRX
	55	UAC:FN344055115E2FAJRX
FSF	75	UAC:FN344075116E2FAJRX
	90	UAC:FN344090116E2FAJRX
	110	UAC:FN3440110118E2FAJRX
	132	UAC:FN3440132118E2FAJXX
FSG	160	UAC:FN3440160118E2FAJXX
	200	UAC:FN3440200118E2FAJXX
	250	2x UAC:FN3440132118E2FAJXX <sup>*)</sup>

<sup>\*)</sup> Parallel connection between two line harmonics filters with 132 kW each

The converters FSA are not assigned to a line harmonics filter. If the rated power of the line harmonics filter is not exceeded, you may operate several converters FSA on a common line harmonics filter.

### Special restrictions for converter FSG

When connecting 400 V converter FSG with line harmonics filters, only the following settings of parameter P1300 are allowed:

- P1300 = 20
- P1300 = 21
- P1300 = 22
- P1300 = 23

For converter FSG with line harmonics filter, operation is only permissible in the vector control mode. It is not permissible for U/f mode to be used.

### 2.6.6 dv/dt filter plus VPL

A combination of dv/dt filter and a voltage peak limiter (VPL) - dv/dt filter plus VPL - are available to suppress voltage peaks and enable longer motor cables to be connected.

 Maximum permissible motor cable length (Page 78)

When using the dv/dt filter plus VPL, observe the following restrictions:

- The maximum output frequency is 150 Hz.
- The maximum pulse frequency is 4 kHz.



Further details for the functional principle and the application cases are available on the Internet (<https://support.industry.siemens.com/cs/ww/en/view/109748645>).

---

**Note**

dv/dt filters plus VPL are available as optional components for converters FSH/FSJ only.

---

**Article number**

Converter frame size	Rated power (kW)	dv/dt filter plus VPL
400 V converters		
FSD	18.5	JTA:TEF1203-0HB
	22 ... 30	JTA:TEF1203-0JB
	37	JTA:TEF1203-0KB
FSE	45	JTA:TEF1203-0LB
	55	
FSF	75	JTA:TEF1203-0MB
	90 ... 132	
FSG	160 ... 250	6SL3000-2DE35-0AA0
FSH	315 ... 400	6SL3000-2DE38-4AA0
FSJ	450 ... 560	6SL3000-2DE41-4AA0
690 V converters		
FSD	3 ... 18.5	JTA:TEF1203-0GB
	22 ... 37	JTA:TEF1203-0HB
FSE	45 ... 55	JTA:TEF1203-0JB
FSF	75 ... 90	JTA:TEF1203-0KB
	110 ... 132	JTA:TEF1203-0LB
FSG	160 ... 250	JTA:TEF1203-0MB
FSH	315 ... 400	6SL3000-2DH35-8AA0
	450	6SL3000-2DH38-1AA0
FSJ	500 ... 630	

### 2.6.7 Push-through mounting kit

The optional push-through mounting kit is used to mount a converter in a control cabinet with its heatsink passing through the cabinet panel. The push-through mounted converters can fulfill a degree of protection of IP20 (UL Open Type).

---

**Note**

Push-through mounting kits are available for converters of frame sizes FSA to FSG only.

---

## Article number

Converter frame size	Article number
FSA	6SL3261-6GA00-0BA0
FSB	6SL3261-6GB00-0BA0
FSC	6SL3261-6GC00-0BA0
FSD	6SL3261-6GD00-0BA0
FSE	6SL3261-6GE00-0BA0
FSF	6SL3261-6GF00-0BA0
FSG	6SL3261-6GG00-0BA0

## Mounting the converter with the push-through mounting kit

The push-through mounting kit comprises two pieces of frames for converter FSA to FSC, and four pieces of frames for converter FSD to FSG.

## Procedure, FSA ... FSC

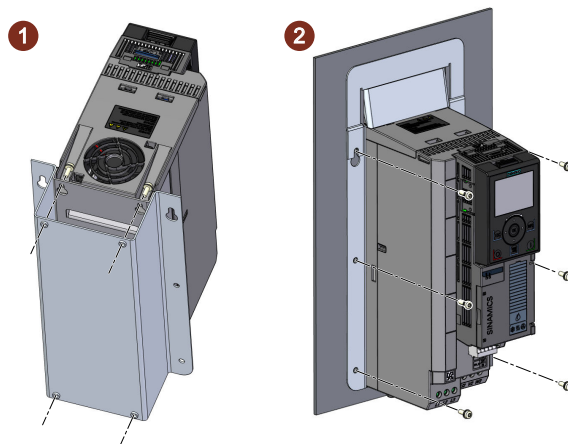



1. Prepare a cutout and holes in the control cabinet panel for the mounting kit.  
 Dimension drawings and drill patterns (Page 60)
2. Fix the U-shape frame to the converter using four screws (step ①).
3. Push the converter heatsink through the cutout of the control cabinet.
4. Attach the top frame to the front of the converter and align its two holes with the holes on the U-shape frame.
5. Fix the converter and the top frame to the cabinet panel with six screws (step ②).

You have correctly installed the converter with the push-through mounting kit.

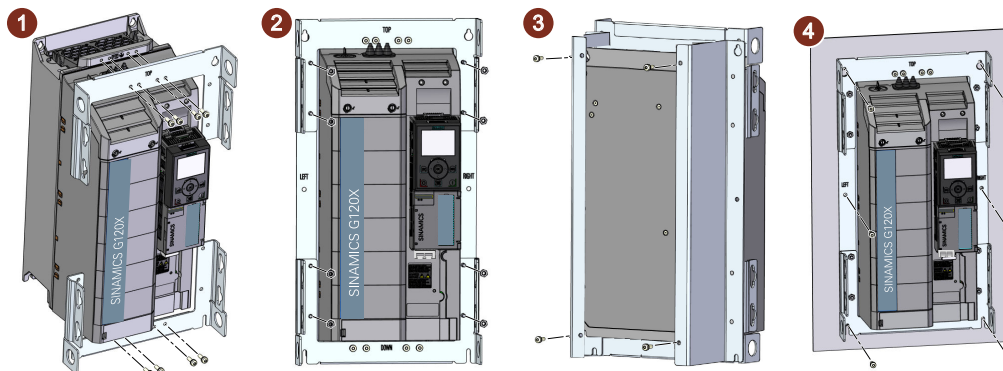

### Procedure, FSD ... FSG



1. Prepare a cutout and holes in the control cabinet panel for the mounting kit.  
 Dimension drawings and drill patterns (Page 60)
2. Fix the top and bottom frames (bearing "TOP" and "BOTTOM" marks respectively) to the converter using eight screws (step ①).
3. For converter FSD to FSF, first attach the left and right frames (bearing "LEFT" and "RIGHT" marks respectively) to the rear of the converter, and then fix them together with the top and bottom frames using eight screw nuts (step ②).  
 For converter FSG, after attaching the left and right frames, you also need to attach four additional support clips from the front of the converter, and fix the clips with all mounting frames together using the screw nuts (see below).



4. Fix the mounting frames in place with four screws at the mounting holes of the converter (step ③).
5. Push the
6. heatsink through the cutout of the control cabinet.
7. Fix the converter with the fixing screws (six for FSD/FSE; eight for FSF/FSG) to the cabinet panel (step ④).

### Mounting the shield connection kit for the Power Module, push-through mounted FSD ... FSG

The push-through mounting kits for converters of frame sizes FSD to FSG provide separate shielding plates for the power connections. In order to connect the line supply and motor cable shields for a push-through mounted converter FSD to FSG, you must use the shielding plate provided in the push-through mounting kit.

**Procedure, FSD ... FSG**

1. Remove the four screws at the bottom of the converter.
2. Attach the shielding plate to the converter and fix it in place by fastening the four screws. For converter FSG, use two additional screws to fix the shielding plate to the cabinet panel.

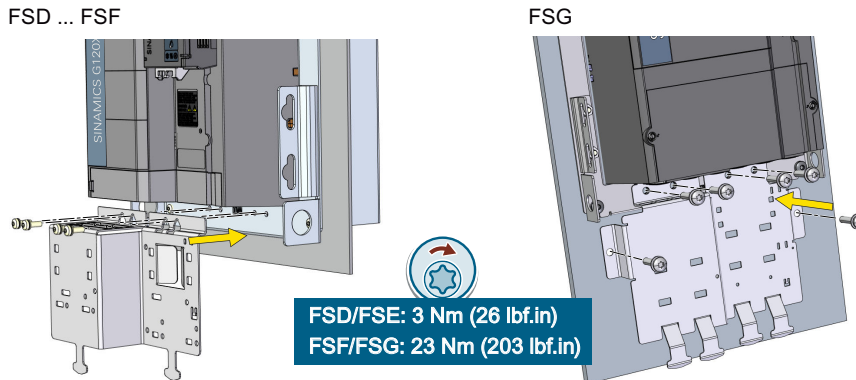

3. If the converter has an integrated line filter, mount the EMC connecting bracket provided in the scope of delivery of the converter. For more information about mounting the EMC connecting bracket, see the following section:

 Mounting the shield connection kits (Page 63)

You have now mounted the shield connection kit.



## 2.6.8 Mounting grips for push-through mounted converters

For the push-through mounted converters FSD to FSG, the optional mounting grips can be used to mount the converters without hoisting gear.

**Article number:** 6SL3200-0SM22-0AA0

For more information about the installation of this optional component, see the following section:

 Additional mounting instructions, FSD ... FSG (Page 65)

## 2.6.9 IP21 top cover

### Overview

The optional IP21 top cover provides extra protection for the converter. The IP21 top cover is mounted above the converter and includes the necessary seals to ensure compliance with degree of protection IP21.

## Mounting

Mounting instructions:

- Mount the IP21 top cover on the control cabinet panel using two screws.
- Mount the IP21 top cover right above the converter so that the cover and converter are aligned by their centers.
- Maintain the clearance to the converter.

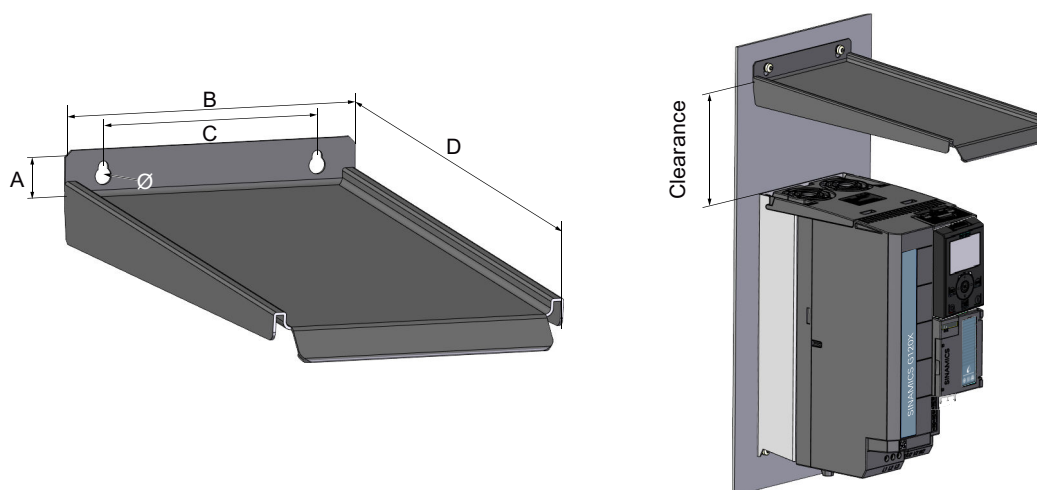

Table 2-1 IP21 top cover dimensions - mm (inch)

Frame size	Clearance	A	B	C	D	Ø	Tightening torque
FSA	100 (3.9)	25 (1.0)	120 (4.7)	80 (3.15)	306 (12.0)	4.5 (0.18)	3 Nm (27 lbf.in)
FSB			160 (6.3)	118 (4.6)		5.5 (0.22)	
FSC		29 (1.1)	260 (10.2)	170 (6.7)	323 (12.7)	6.0 (0.24)	6 Nm (53 lbf.in)
FSD	300 (11.8)		335 (13.2)	230 (9.1)	443 (17.4)		
FSE			365 (14.4)	270 (10.6)			
FSF, FSG							

## Article number

Converter frame size	Article number
FSA	6SL3266-1PA00-0BA0
FSB	6SL3266-1PB00-0BA0
FSC, FSD	6SL3266-1PD00-0BA0
FSE	6SL3266-1PE00-0BA0
FSF, FSG	6SL3266-1PF00-0BA0
FSH, FSJ	Not available

2.6 Optional components

**2.6.10 Operator panel**

An operator panel has been designed to enhance the interface and communications capabilities of the converter. It can be used to commission, troubleshoot and control the converter, as well as to back up and transfer the converter settings. The operator panels (BOP-2 and IOP-2) can be mounted either directly on the converter or in a control cabinet door using a door mounting kit.

**Article number**

Basic Operator Panel 2 (BOP-2)	6SL3255-0AA00-4CA1
Intelligent Operator Panel 2 (IOP-2)	6SL3255-0AA00-4JA2
Door mounting kit for the operator panel	6SL3256-0AP00-0JA0
IOP-2 Handheld	6SL3255-0AA00-4HA1

**2.6.11 SINAMICS G120 Smart Access**

The SINAMICS G120 Smart Access is a Wi-Fi-based Web server module and an engineering tool. It has been designed for quick commissioning, parameterization, and maintenance of the converters.

**Article number:** 6SL3255-0AA00-5AA0

## 2.7 Motors and multi-motor drives that can be operated

### Siemens motors that can be operated

You can connect standard induction motors to the converter.

You can find information on further motors on the Internet:

 Motors that can be operated (<https://support.industry.siemens.com/cs/ww/en/view/100426622>)

### Third-party motors that can be operated

You can operate standard asynchronous motors from other manufacturers with the converter:

<b>NOTICE</b>
<b>Insulation failure due to unsuitable third-party motor</b>
A higher load occurs on the motor insulation in converter mode than with line operation. Damage to the motor winding may occur as a result.
<ul style="list-style-type: none"><li>• Please observe the notes in the System Manual "Requirements for third-party motors"</li></ul>



Further information is provided on the Internet:

 Requirements for third-party motors (<https://support.industry.siemens.com/cs/ww/en/view/79690594>)

### Multi-motor operation

Multi-motor operation involves simultaneously operating several motors from one converter. For standard induction motors, multi-motor operation is generally permissible.

Additional preconditions and restrictions relating to multi-motor operation are available on the Internet:

 Multi-motor drive (<http://support.automation.siemens.com/WW/view/en/84049346>)

*Description*

---

*2.7 Motors and multi-motor drives that can be operated*



## Mounting

### 3.1 Installing the label for the North American market

#### Description

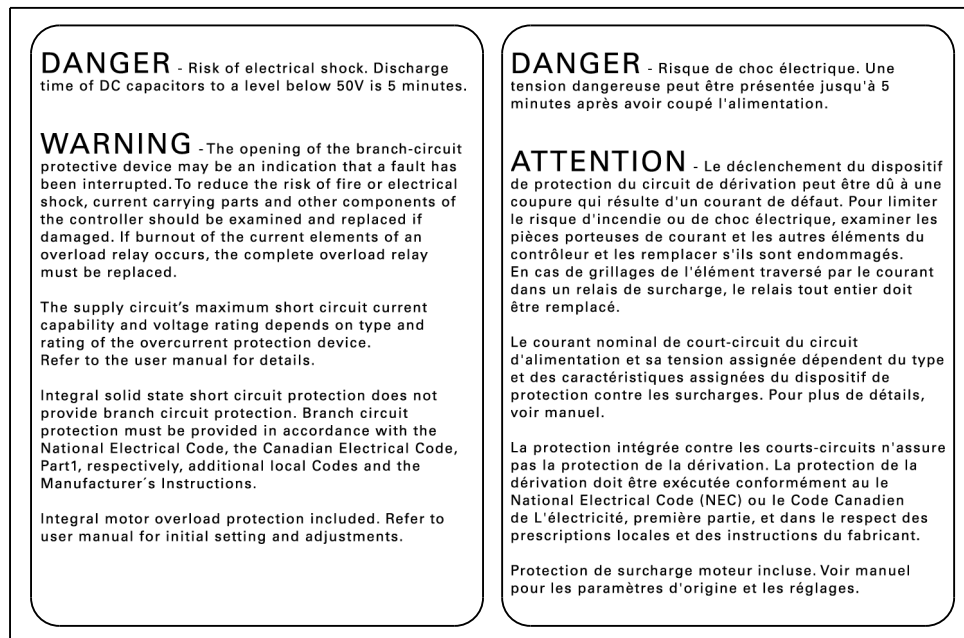

Figure 3-1 Adhesive label with danger and warning notes for North America

The converter is supplied with an adhesive label with danger and warning notes for the North American market.

Attach the adhesive label in the required language to the inside of the control cabinet where it is clearly visible at all times.

### 3.2 EMC-compliant setup of the machine or plant

The converter is designed for operation in industrial environments where strong electromagnetic fields are to be expected.

Reliable and disturbance-free operation is only guaranteed for EMC-compliant installation.

To achieve this, subdivide the control cabinet and the machine or system into EMC zones:

#### EMC zones

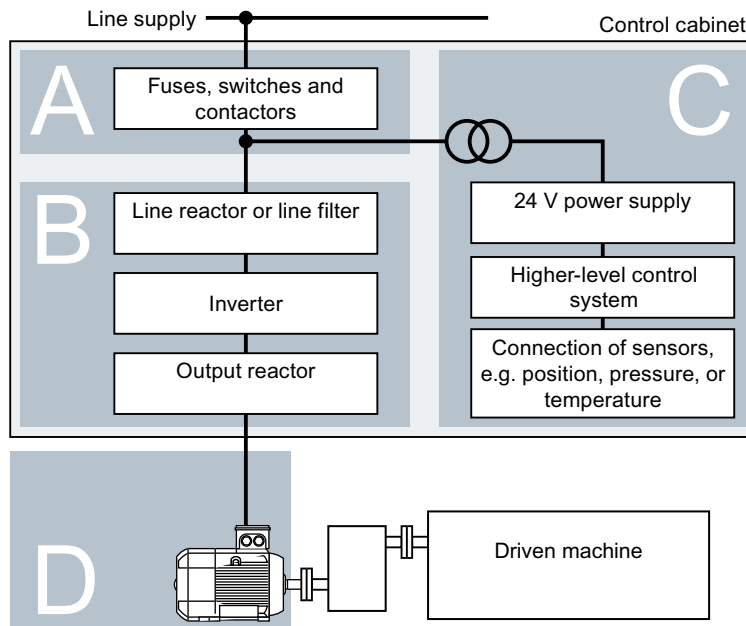

Figure 3-2 Example of the EMC zones of a plant or machine

#### Inside the control cabinet

- Zone A: Line supply connection
- Zone B: Power electronics  
Devices in Zone B generate energy-rich electromagnetic fields.
- Zone C: Control and sensors  
Devices in Zone C do not generate any energy-rich electromagnetic fields themselves, but their functions can be impaired by electromagnetic fields.

#### Outside the control cabinet

- Zone D: Motors  
Devices in Zone D generate electromagnetic fields with a significant amount of energy

### 3.2.1 Control cabinet

- Assign the various devices to zones in the control cabinet.
- Electromagnetically uncouple the zones from each other by means of one of the following actions:
  - Side clearance  $\geq 25$  cm
  - Separate metal enclosure
  - Large-area partition plates
- Route cables of various zones in separate cable harnesses or cable ducts.
- Install filters or isolation amplifiers at the interfaces of the zones.

#### Control cabinet assembly

- Connect the door, side panels, top and base plate of the control cabinet with the control cabinet frame using one of the following methods:
  - Electrical contact surface of several  $\text{cm}^2$  for each contact location
  - Several screw connections
  - Short, finely stranded, braided copper wires with cross-sections  $\geq 95 \text{ mm}^2 / 000 (3/0) (-2)$  AWG
- Install a shield support for shielded cables that are routed out of the control cabinet.
- Connect the PE bar and the shield support to the control cabinet frame through a large surface area to establish a good electrical connection.
- Mount the control cabinet components on a bare metal mounting plate.
- Connect the mounting plate to the control cabinet frame and PE bar and shield support through a large surface area to establish a good electrical connection.
- For screw connections onto painted or anodized surfaces, establish a good conductive contact using one of the following methods:
  - Use special (serrated) contact washers that cut through the painted or anodized surface.
  - Remove the insulating coating at the contact locations.

#### Measures required for several control cabinets

- Install equipotential bonding for all control cabinets.
- Screw the frames of the control cabinets together at several locations through a large surface area using serrated washers to establish a good electrical connection.
- In plants and systems where the control cabinets are lined up next to one another, and which are installed in two groups back to back, connect the PE bars of the two cabinet groups at as many locations as possible.

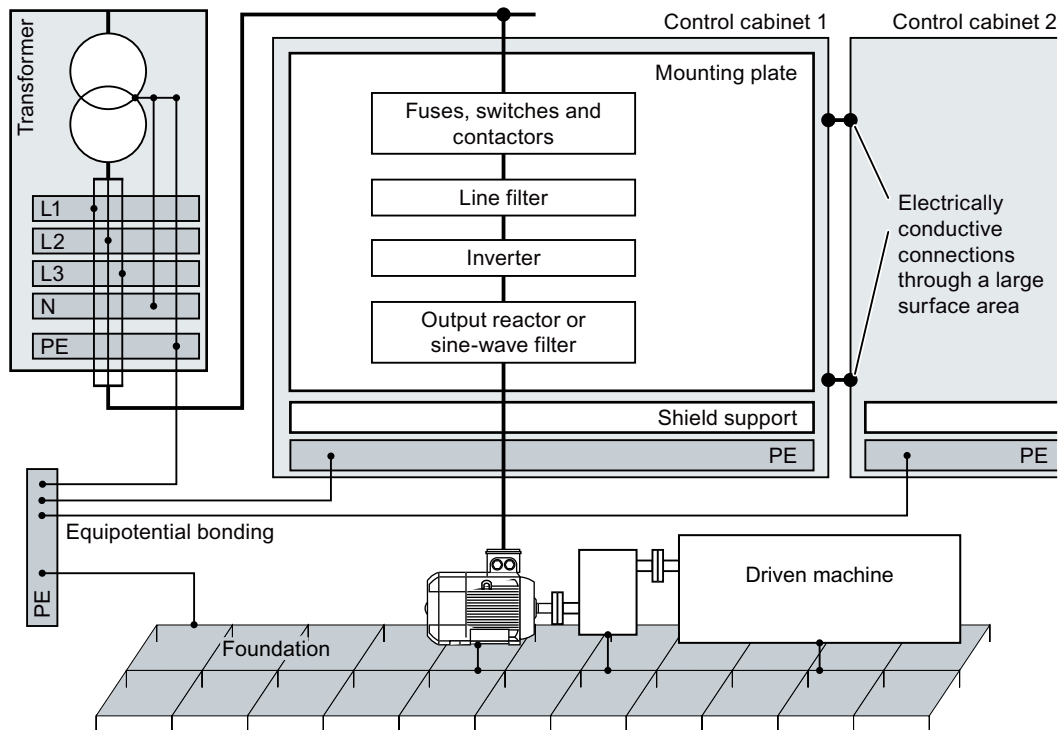

Figure 3-3 Grounding and high-frequency equipotential bonding measures in the control cabinet and in the plant/system

### Further information

Additional information about EMC-compliant installation is available in the Internet:

 EMC installation guideline (<http://support.automation.siemens.com/WW/view/en/60612658>)

### 3.2.2 Cables

Cables with a high level of interference and cables with a low level of interference are connected to the converter:

- Cables with a high level of interference:
  - Cable between the line filter and converter
  - Motor cable
  - Cable at the converter DC link connection
- Cables with a low level of interference:
  - Cable between the line and line filter
  - Signal and data cables

### Cable routing inside the cabinet

- Route the power cables with a high level of interference so that there is a minimum clearance of 25 cm to cables with a low level of interference.  
If the minimum clearance of 25 cm is not possible, insert separating metal sheets between the cables with a high level of interference and cables with a low level of interference.  
Connect these separating metal sheets to the mounting plate to establish a good electrical connection.
- Cables with a high level of interference and cables with a low level of interference may only cross over at right angles:
- Keep all of the cables as short as possible.
- Route all of the cables close to the mounting plates or cabinet frames.
- Route signal and data cables - as well as the associated equipotential bonding cables - parallel and close to one another.
- Twist incoming and outgoing unshielded individual conductors.  
Alternatively, you can route incoming and outgoing conductors in parallel, but close to one another.
- Ground any unused conductors of signal and data cables at both ends.
- Signal and data cables must only enter the cabinet from one side, e.g. from below.
- Using shielded cables for the following connections:
  - Cable between the converter and line filter
  - Cable between the converter and output reactor

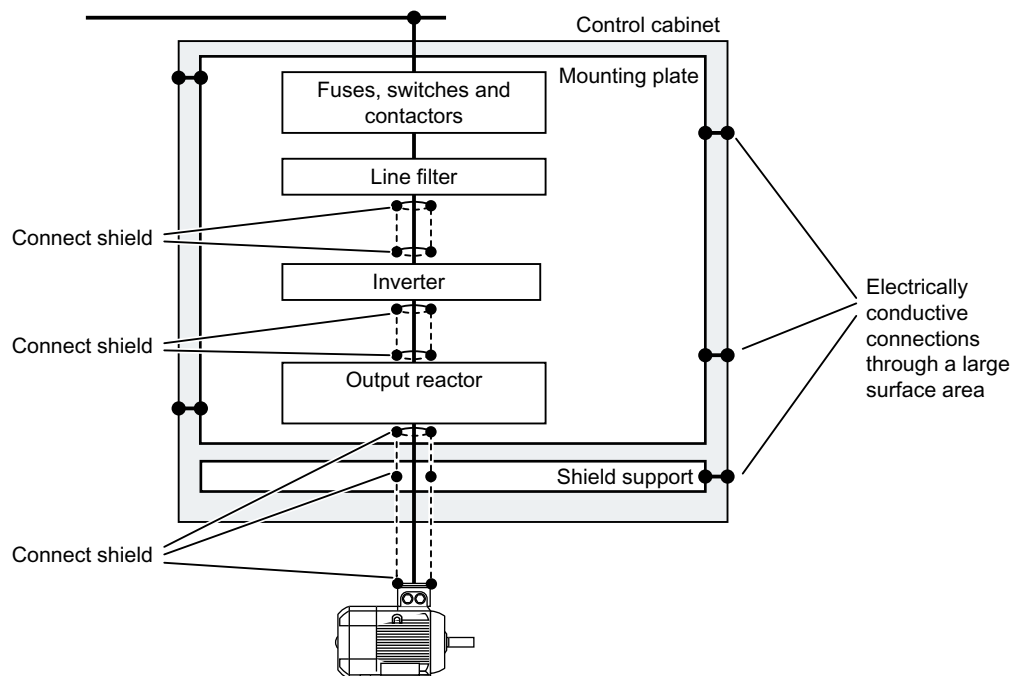

Figure 3-4 Routing converter cables inside and outside a control cabinet

**Routing cables outside the control cabinet**

- Maintain a minimum clearance of 25 cm between cables with a high level of interference and cables with a low level of interference.
- Using shielded cables for the following connections:
  - Converter motor cable
  - Signal and data cables
- Connect the motor cable shield to the motor enclosure using a PG gland that establishes a good electrical connection.

**Requirements relating to shielded cables**

- Use cables with finely-stranded, braided shields.
- Connect the shield to at least one end of the cable.

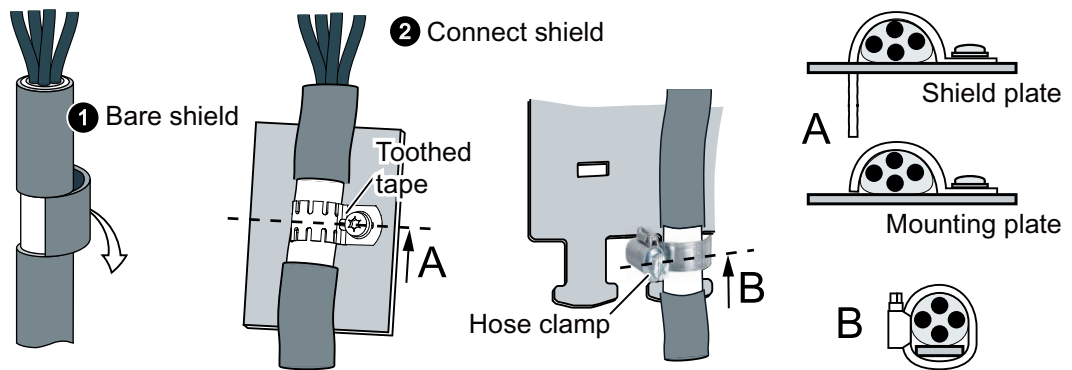

Figure 3-5 Examples for EMC-compliant shield support

- Attach the shield to the shield support directly after the cable enters the cabinet.
- Do not interrupt the shield.
- Only use metallic or metallized plug connectors for shielded data cables.

**3.2.3 Electromechanical components**

**Surge voltage protection circuit**

- Connect surge voltage protection circuits to the following components:
  - Coils of contactors
  - Relays
  - Solenoid valves
  - Motor holding brakes
- Connect the surge voltage protection circuit directly at the coil.
- Use RC elements or varistors for AC-operated coils and freewheeling diodes or varistors for DC-operated coils.

## 3.3 Power losses and air cooling requirements

### Overview

To protect the components from overheating, the control cabinet requires a cooling air flow, which depends on the power loss of the individual components.

### Measures in order to ensure that the components are adequately cooled

- Add the power losses of the individual components.
  -  Technical data (Page 895)
  - Use the manufacturers' data for components, for example reactors or filters.
- Calculate the air flow required:  
airflow [l/s] = power loss [W] \* 0.86 / ΔT [K]  
Power loss: Total of the power losses of the individual components.  
Δ T: Permissible temperature rise in the control cabinet.
- Ensure that the control cabinet is appropriately ventilated and equipped with suitable air filters.
- Ensure that the components maintain the specified clearances with respect to one another.
- Ensure that the components are provided with adequate cooling air through the cooling openings.
- Use the appropriate air barriers to prevent cooling air short circuits.
- Ensure that the electrical cabinet is adequately ventilated and is equipped with suitable air filters.  
Comply with the replacement intervals of the air filter.

Further measures

Air barriers can prevent converters from overheating each other. Such measures are only necessary in extreme cases when the cooling air temperature reaches the maximum ambient temperature of the inverter.

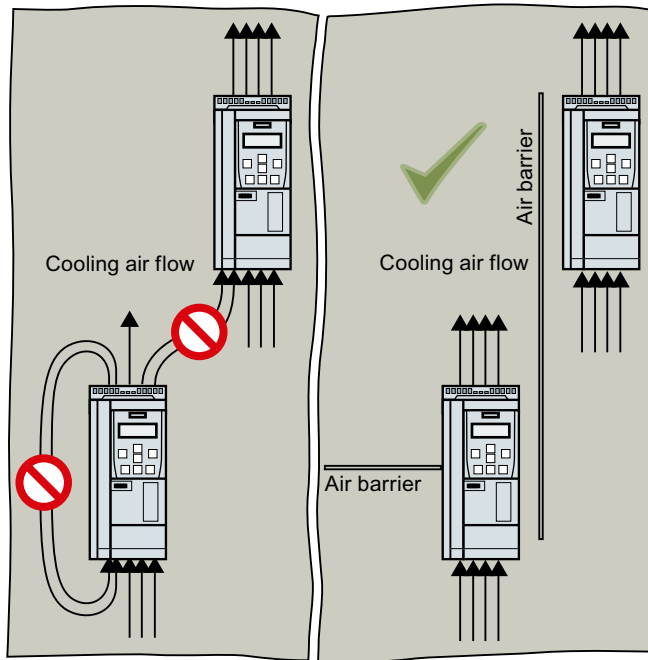



## 3.4 Mounting the converter

### 3.4.1 Basic installation rules

#### Requirements

##### General installation conditions

When installing the converters carefully observe the conditions listed below in order to guarantee reliable, continuous and disturbance-free operation.

- The converters are designed for installation in a control cabinet.
- The converters are suitable for mounting on concrete or other non-combustible surfaces only, for example, on a bare metal mounting plate.
- The converters comply with degree of protection IP20 according to IEC 60529. The converters utilizing push-through technology fulfill a degree of protection of IP20 (UL Open Type).
- The converters are certified for use in environments with degree of pollution 2 without condensation, that is in environments where no conductive pollution/dirt occurs. Condensation is not permissible.
- Ensure that the device is free of dust and dirt. When using a vacuum cleaner, this must comply with ESD equipment rules.
- Keep the device away from water, solvents and chemicals. Take care to install it away from potential water hazards, for example, do not install it beneath pipes that are subject to condensation. Avoid installing it where excessive humidity and condensation may occur.
- Keep the device within the maximum and minimum operating temperatures. At temperatures > 40 °C and installation altitudes > 1000 m, the devices must be derated.
- Ensure that the correct level of ventilation and air flow is provided.
- Fast temperature changes of the air drawn in (for example, by using cooling units) are not permitted due to the danger of condensation.
- Ensure that all converters and the cabinet are grounded according to the EMC guidelines  EMC-compliant setup of the machine or plant (Page 48)

##### Converters for systems in the United States/Canada (UL/cUL)

- For a system configuration in conformance with UL/cUL, use the UL/cUL-approved fuses or circuit breakers under the following Internet address:  
 Fuses and circuit breakers (<https://support.industry.siemens.com/cs/ww/en/ps/13213>)
- The converter of frame size FSA has to be mounted in an enclosure sized min. 500 mm (height) × 400 mm (depth) × 255 mm (width).

3.4 Mounting the converter

- The integrated solid-state short-circuit protection does not provide branch circuit protection.
  - UL: Branch circuit protection must be provided in accordance with the Manufacturer Instructions, National Electrical Code and any additional local codes.
  - CSA: Branch circuit protection must be provided in accordance with the Canadian Electrical Code, Part I
- On the system side, provide branch circuit protection in conformance with NEC or CEC, Part 1, and the local regulations.
- The converters provide internal motor protection corresponding to UL61800-5-1. The protection threshold is 115% of the converter full load current. When commissioning, you can adapt the motor overload protection using parameter p0640.
- For frame sizes FSF and FSG, to connect the line supply and motor only use UL approved ring-type cable lugs (ZMVV), which are certified for the particular voltage, with a permissible current of at least 125% of the input and output current. Use the higher value as basis.
- The line and output voltage may not be lower than 400 V or higher than 600 V.
- Only use copper cables rated for 60 °C/75 °C. For converters FSA to FSC, only use copper cables rated for 75 °C <sup>1)</sup>.

<sup>1)</sup>When connecting a cable with a higher rated temperature, do not reduce the cable cross-section.

Example: If a cable with a rated temperature of 60 °C is specified, the cable cross-section must also be rated according to 60 °C. When connecting a cable with a higher rated temperature, e. g. 90 °C, you must determine the cable cross-section as if the cable had a rated temperature of 60 °C.

 <b>WARNING</b>
<b>Risk of explosion or spread of fire from built-in devices</b>
Short circuits in the converter or its components may cause explosion or fire in the control cabinet, which can result in serious personal injury or property damage.
<ul style="list-style-type: none"><li>• Install built-in devices in a suitable and robust metal cabinet in such a way that personnel are protected against the explosive shock and fire, or take other appropriate protection measures, for example, using five safety cabinet locks additionally.</li></ul>

**Protection against the spread of fire**

The device may be operated only in closed housings or in control cabinets with protective covers that are closed, and when all of the protective devices are used. The installation of the device in a metal control cabinet or the protection with another equivalent measure must prevent the spread of fire and emissions outside the control cabinet.

**Protection against condensation or electrically conductive contamination**

Protect the device, e.g. by installing it in a control cabinet with degree of protection IP54 according to IEC 60529 or NEMA 12. Further measures may be necessary for particularly critical operating conditions.

If condensation or conductive pollution can be excluded at the installation site, a lower degree of control cabinet protection may be permitted.

### Mounting position

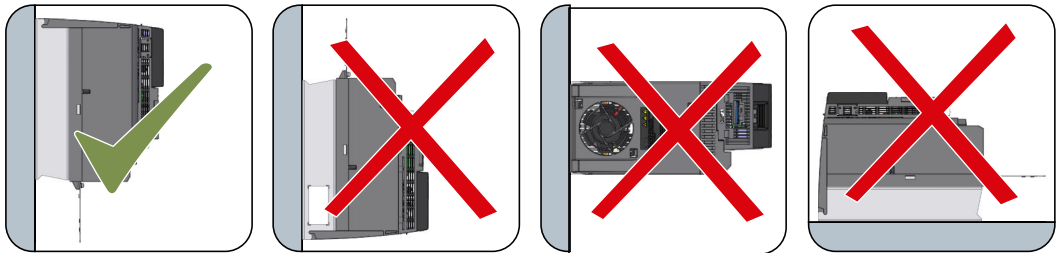

Figure 3-6 Only mount in the vertical position with the line connection at the bottom

## 3.4.2 Dimension drawings and drill patterns

### Overview

The converters are designed to be mounted in accordance with the dimension drawings, in a cabinet using screws, nuts and washers.

---

#### Note

To comply with EMC specifications, it is recommended to mount the converter on an electrically conductive mounting panel in the cabinet. This mounting panel should be connected to the cabinet PE.

---

3.4.2.1 Mounting the converter on the mounting panel

Dimensions and clearance distances - mm (in)

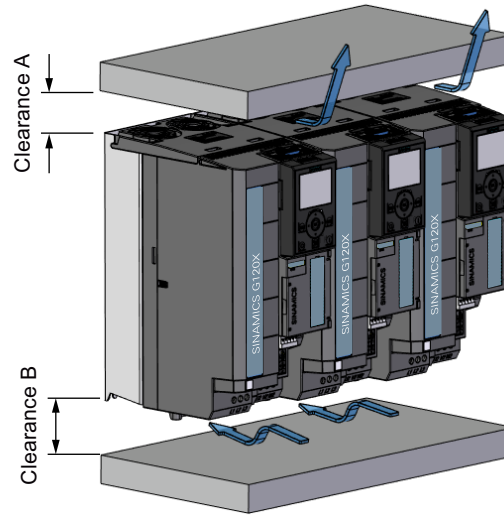
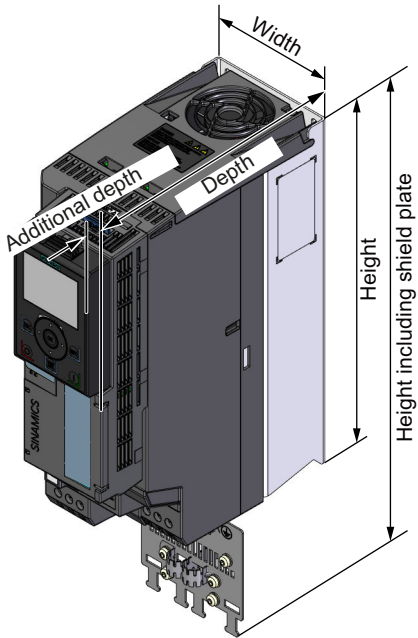

Frame size	Height	Height including shield plate	Width	Depth	Additional depth		Clearance <sup>1)</sup>			
					With operator panel	With G120 Smart Access	A	B	lateral	front
FSA	232 (9.1)	330 (13.0)	73 (2.8)	209 (8.2)	9 (0.4)	7 (0.3)	80 (3.1)	100 (3.9)	0 <sup>2)</sup>	-
FSB	275 (10.8)	383 (15.1)	100 (3.9)	209 (8.2)	9 (0.4)	7 (0.3)	80 (3.1)	100 (3.9)	0 <sup>2)</sup>	-
FSC	295 (11.6)	423 (16.7)	140 (5.5)	209 (8.2)	9 (0.4)	7 (0.3)	80 (3.1)	100 (3.9)	0 <sup>2)</sup>	-
FSD	472 (18.6)	625 (24.6)	200 (7.9)	239 (9.4)	9 (0.4)	7 (0.3)	300 (11.8)	350 (13.8)	0 <sup>2)</sup>	-
FSE	551 (21.7)	729 (28.7)	275 (10.8)	239 (9.4)	9 (0.4)	7 (0.3)	300 (11.8)	350 (13.8)	0 <sup>2)</sup>	-
FSF	709 (27.9)	969 (38.1)	305 (12)	360 (14.2)	9 (0.4)	7 (0.3)	300 (11.8)	350 (13.8)	0 <sup>2)</sup>	-
FSG	999 (39.3)	1255 (49.4)	305 (12)	360 (14.2)	9 (0.4)	7 (0.3)	300 (11.8)	350 (13.8)	0 <sup>2)</sup>	-

Frame size	Height	Height including shield plate	Width	Depth	Additional depth		Clearance <sup>1)</sup>			
					With operator panel	With G120 Smart Access	A	B	lateral	front
FSH	1696 (66.7)	-	548 (21.6)	393 (15.5)	-	-	200 (7.9)	250 (9.8)	30 (1.2)	100 (3.9)
FSJ	1621 (63.8)	-	801 (31.5)	393 (15.5)	-	-	200 (7.9)	250 (9.8)	30 (1.2)	100 (3.9)

- 1) The cooling air clearances A and B refer to the converter without shield plate.
- 2) Maximum surrounding air temperature during operation dependent on lateral clearance:
- Max. 50 °C for mounting with 0 mm lateral clearance (for tolerance reasons, we recommend a lateral clearance of approx. 1 mm.)
  - Max. 55 °C for mounting with 50 mm lateral clearance.

### Drill patterns - mm (in)

Table 3-1 FSA ... FSG

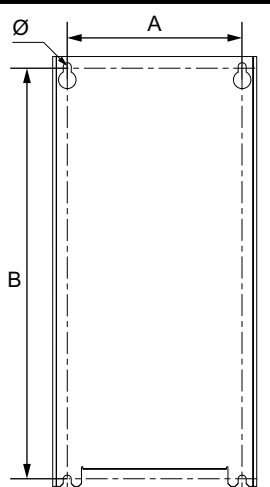
Drill pattern	Dimensions	FSA	FSB	FSC	FSD	FSE	FSF	FSG
	A	55 (2.2)	80 (3.2)	118 (4.6)	170 (6.7)	230 (9.1)	270 (10.6)	265 (10.4)
	B	221.5 (8.7)	265 (10.4)	283 (11.1)	430 (16.9)	509 (20.0)	680 (26.8)	970.5 (38.2)
	Ø	5 (0.2)	5 (0.2)	5.5 (0.2)	6.0 (0.2)	6.5 (0.3)	8.5 (0.3)	12 (0.5)
	Fixings (bolts, washers, nuts)	4 × M4	4 × M4	4 × M5	4 × M5	4 × M6	4 × M8	4 × M10
	Tightening torque - Nm (lbf. in)	2.5 (22.1)	2.5 (22.1)	2.5 (22.1)	6 (53.1)	10 (88.5)	25 (221.3)	50 (442.5)

Note: For the converters FSD to FSG, a printed drill pattern is supplied with each converter. This can be used to easily drill the necessary mounting holes.

3.4 Mounting the converter

Table 3-2 FSH and FSJ

Drill pattern	Dimensions	FSH	FSJ
	A1	160 (6.3)	200 (7.9)
	A2	150 (5.9)	290 (11.4)
	A3	160 (6.3)	200 (7.9)
	A4	225 (8.9)	345 (13.6)
	A5	225 (8.9)	345 (13.6)
	B	1419 (55.9)	1399 (55.1)
	G1	39 (1.5)	60.5 (2.4)
	G2	49 (1.9)	60.5 (2.4)
	Ø	20 (0.8)	20 (0.8)
	Fixings (bolts, washers, nuts)	7 × M8	7 × M8
	Tightening torque - Nm (lbf. in)	25 (221.3)	25 (221.3)

3.4.2.2 Mounting the converter utilizing push-through technology (FSA to FSG only)

Use the optional mounting kit to mount a converter in push-through technology in a control cabinet. Mounting instructions are provided in the following section:

Push-through mounting kit (Page 39)

The following dimension drawings and drilling patterns are not to scale.

Panel thickness of the control cabinet ≤ 3.5 mm

Mounting dimensions - mm (in)

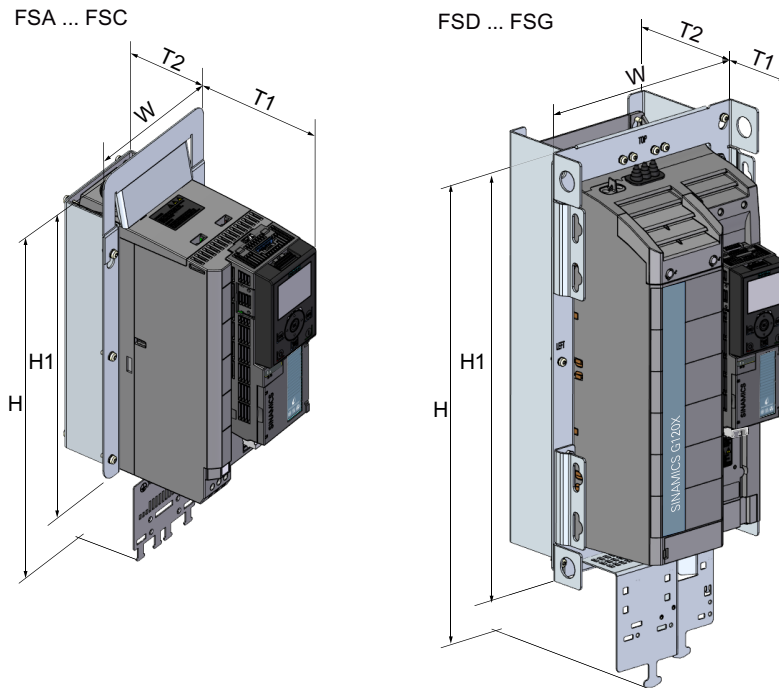

Frame size	Width (W)	Height		Depth	
		H (with shield plate)	H1 (without shield plate)	T1	T2
FSA	127 (5.0)	390 (15.4)	300 (11.8)	160 (6.3)	57 (2.2)
FSB	154 (6.1)	450 (17.7)	345 (13.6)	153 (6.0)	66 (2.6)
FSC	192 (7.6)	473 (18.6)	361 (14.2)	154 (6.1)	65 (2.5)
FSD	271 (10.6)	647 (25.5)	514 (20.2)	142 (5.6)	98 (3.9)
FSE	360 (14.2)	773 (30.4)	600 (23.6)	145 (5.7)	93 (3.7)
FSF	396 (15.6)	1003 (39.5)	749 (29.5)	185 (7.3)	185 (7.3)
FSG	384 (15.1)	1275 (50.2)	1026 (40.4)	184 (7.2)	188 (7.4)

3.4 Mounting the converter

Cutouts and drilling patterns - mm (in)

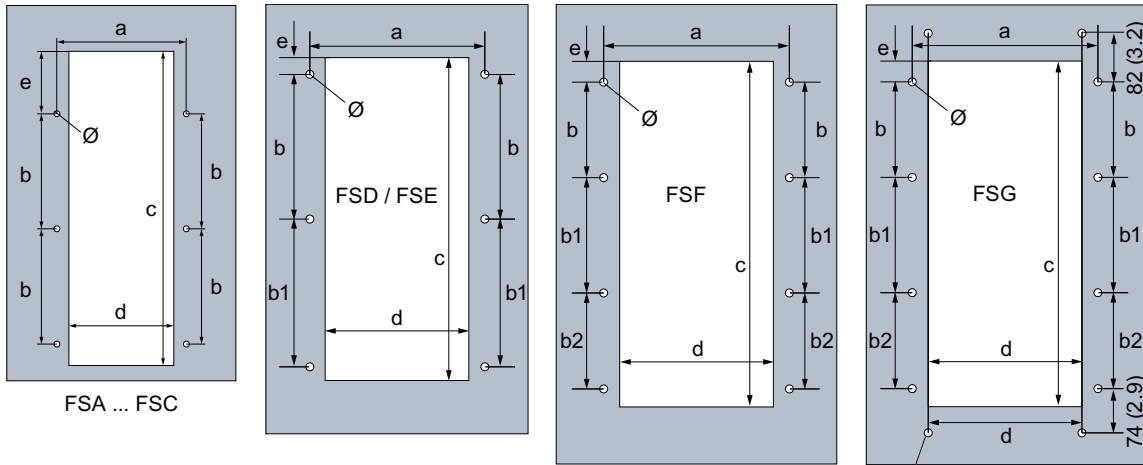

\* Four holes for mounting the shielding plate

Frame size	Drilling dimensions - mm (in)								Fixings	Tightening torque - Nm (lbf.in)
	a	b	b1	b2	c	d	e	Ø		
FSA	105.5 (4.2)	102.5 (4.0)	-	-	273 (10.7)	82 (3.2)	45 (1.8)	5 (0.2)	4 × M4	2.5 (22.1)
FSB	132.5 (5.2)	117 (4.6)	-	-	316 (12.4)	109 (4.3)	45 (1.8)	5 (0.2)	4 × M4	2.5 (22.1)
FSC	170.5 (6.7)	120.5 (4.7)	-	-	334 (13.2)	149 (5.9)	45 (1.8)	5.5 (0.2)	4 × M5	2.5 (22.1)
FSD	246 (9.7)	235 (9.3)	241 (9.5)	-	497 (19.6)	216 (8.5)	10.5 (0.4)	7 (0.3)	6 × M5	6 (53.1)
FSE	323 (12.7)	275 (10.8)	281 (11.1)	-	588 (23)	292 (11.5)	19 (0.7)	7 (0.3)	6 × M5	6 (53.1)
FSF	350 (13.8)	220 (8.7)	250 (9.8)	226 (8.9)	731 (28.8)	324 (12.8)	20.5 (0.8)	10 (0.4)	8 × M8	25 (221.3)
FSG	350 (13.8)	328 (12.9)	330 (13)	328 (12.9)	1015 (40)	324 (12.8)	14.6 (0.6)	10/11*(0.4)	8 × M8/ 4 × M10*	25 (221.3)/ 50 (442.5)*

\* Four holes for mounting the shielding plate



### 3.4.3 Mounting the shield connection kits

#### Overview

We recommend that you mount the shield connection kits provided. The shield connection kit makes it simpler to install the converter in compliance with EMC regulations and to provide strength relief for the connected cables.

#### Mounting the shield connection kit for the Control Unit

---

##### Note

The shield connection kit for the Control Unit is available for converters FSD to FSG only.

---

Attach the shielding plate to the bottom of the Control Unit, and use a cross-tip screwdriver to tighten the screw to fix it onto the converter.

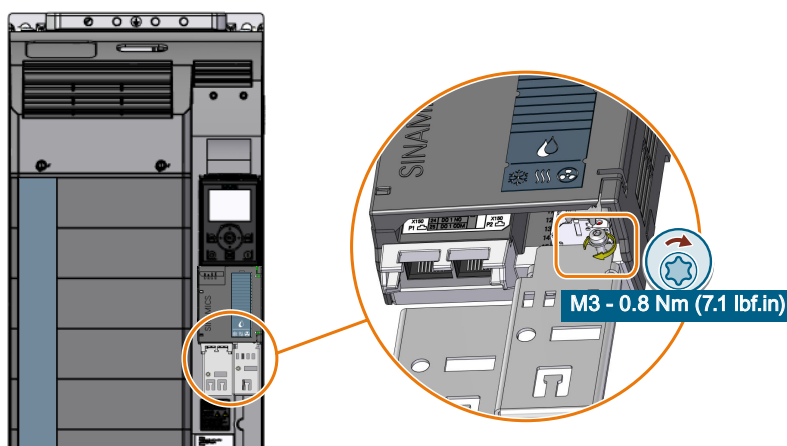

#### Mounting the shield connection kit for the Power Module, FSA ... FSC

##### Procedure

1. Remove the two screws and two U clamps from the bottom of the converter ①.
2. Mount the two U clamps with the two screws on the shield plate ②.
3. Fasten the shield plate in place using two screws ③.

3.4 Mounting the converter

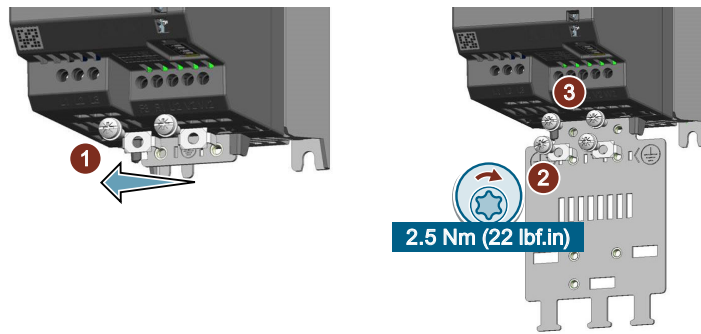

You have now mounted the shield connection kit.



Mounting the shield connection kit for the Power Module, FSD ... FSG

Note

For a push-through mounted converter FSD ... FSG, use the shielding plate provided in the push-through mounting kit.

 Push-through mounting kit (Page 39)

Procedure, FSD/FSE

1. Attach the shielding plate to the bottom of the converter and fasten it in place using four screws ①.
2. If the converter has an integrated line filter, mount the EMC connecting bracket additionally.
  - a. Slide the EMC connecting bracket into the converter, so that it is held in the converter by the clamping spring ②.  
The EMC connecting bracket is positioned correctly if you feel some resistance when pulling it out from the converter.
  - b. Having ensured that it is positioned correctly, fasten the EMC connecting bracket in place using three screws ③.

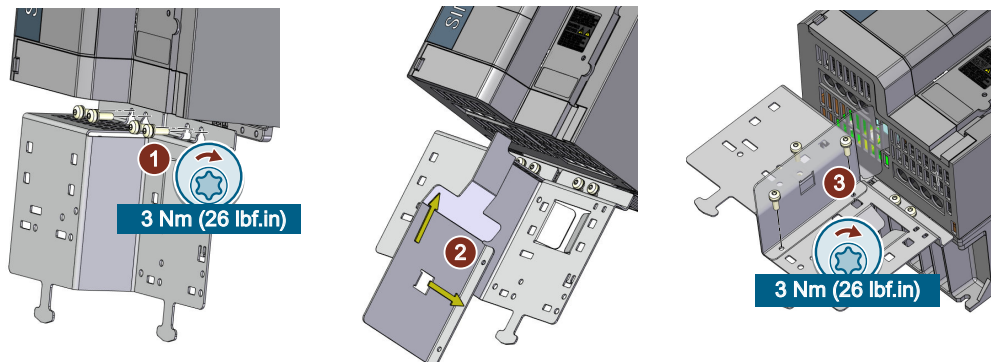

You have now mounted the shield connection kit.



**Procedure, FSF**

1. Attach the shielding plate to the bottom of the converter and fasten it in place using four screws ①.
2. If the converter has an integrated line filter, mount the EMC connecting bracket additionally by fastening it to the shielding plate with four screws ②.

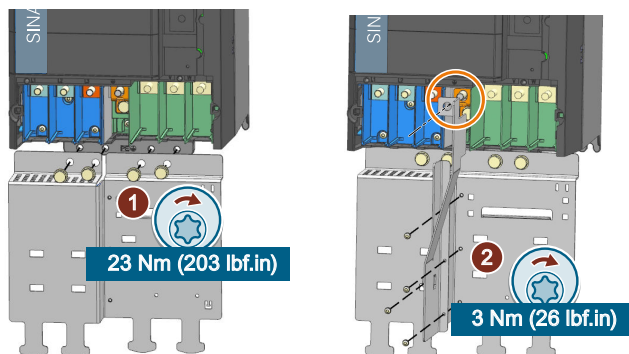

You have now mounted the shield connection kit.



**Procedure, FSG**

1. Secure each side part to the shielding plate with two screws ①.
2. Attach the shielding plate to the bottom of the converter and fasten it in place using six screws ②.
3. If the converter has an integrated line filter, mount the EMC connecting bracket additionally by fastening it to the shielding plate with four screws ③.

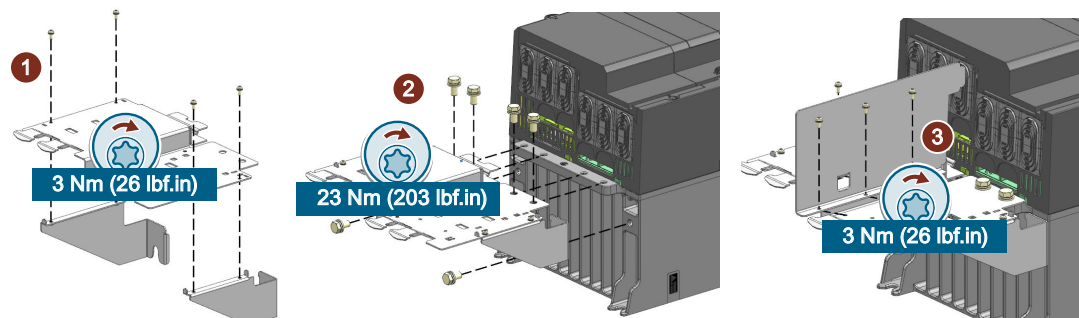

You have now mounted the shield connection kit.



**3.4.4 Additional mounting instructions for FSD ... FSJ**

**3.4.4.1 Additional mounting instructions, FSD ... FSG**

When mounting the converters FSD to FSG, the weight of the converter should be considered and appropriate hoisting gear for mounting should be applied.

converter weight:

 Technical data dependent on the power (Page 903)

### Hoisting gear

#### For cabinet panel mounted converters

Use crane lifting lugs and the appropriate hoisting gear when mounting the converters on the cabinet panel.

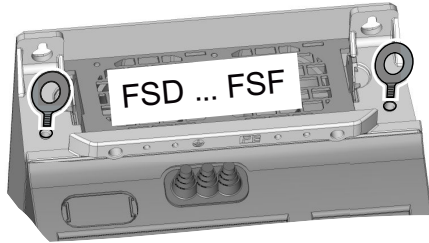

#### For push-through mounted converters

Use the hoisting gear shown below when mounting the converters utilizing push-through technology.

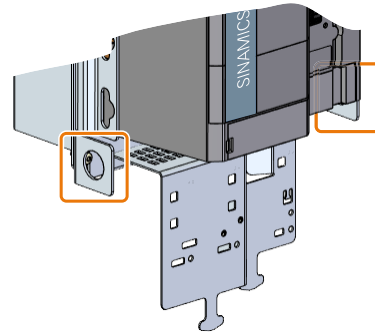
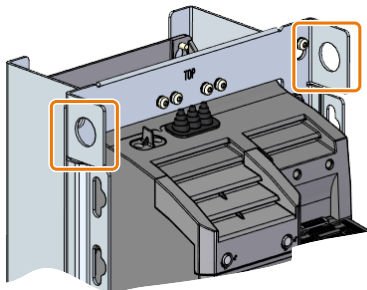

## Mounting grips

Alternatively, you can use the mounting grips to mount the push-through mounted converters without hoisting gear. Install the four mounting grips as shown below.

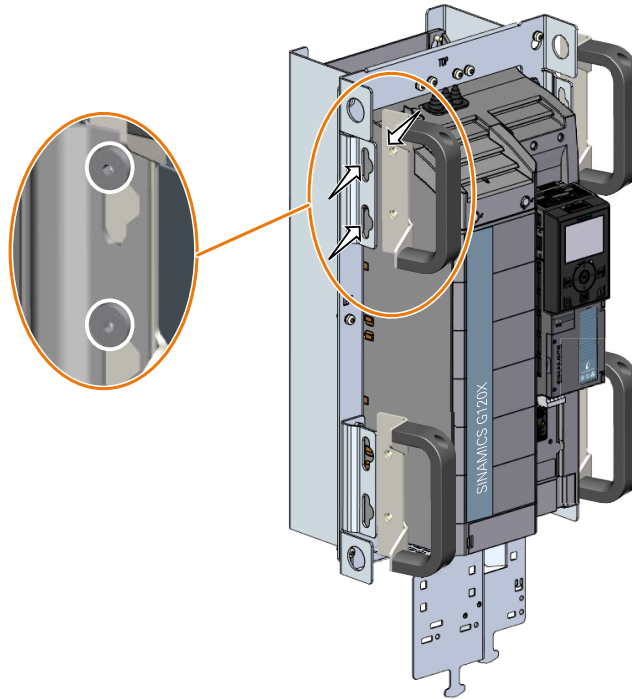

3.4.4.2 Additional mounting instructions, FSH/FSJ

Installing

Removing the pallet

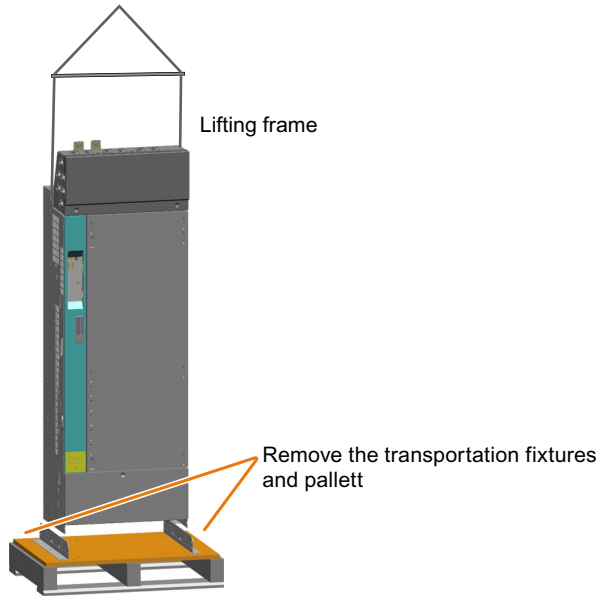

Lifting the converter into the cabinet

The converters FSH and FSJ can be lifted into the cabinet with the lifting eyes. Use a lifting harness where the ropes or chains are maintained in a vertical position. The device must not be lifted at an angle because this can damage the housing. Rope spreaders may have to be used.

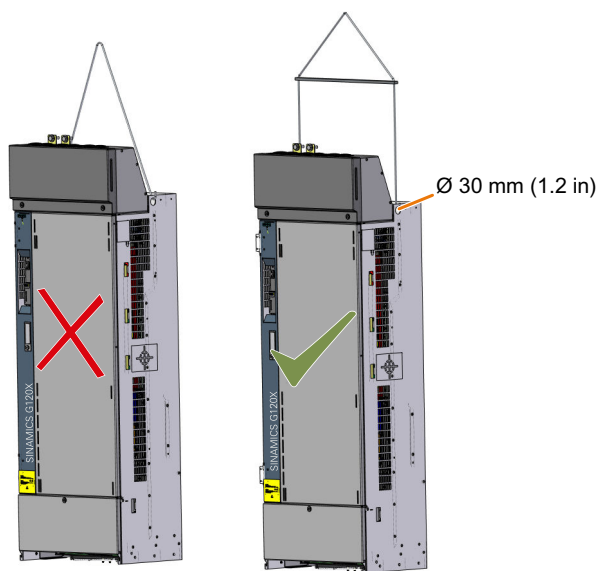

The electrical cabinet installation must be realized in accordance with the dimension drawings supplied. The minimum cabinet sizes for the installation of converters FSH and FSJ are provided as follows:

- For FSH: 800 mm (width) × 2000 mm (height) × 600 mm (depth)
- For FSJ: 1000 mm (width) × 2000 mm (height) × 600 mm (depth)

Before converter installation, remove the side, back, and top plates from the cabinet frame, and mount at least two support plates in the cabinet.

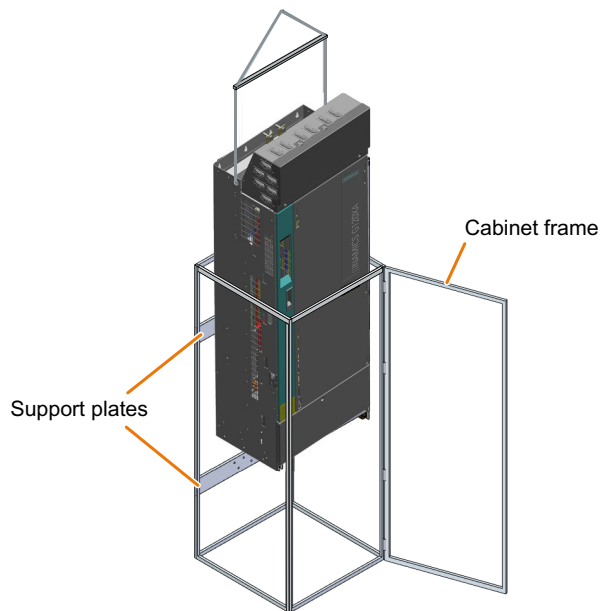

After the converter is installed in the cabinet, install the side, back, and top plates back to the cabinet frame.

### 3.4.5 Mounting the optional components

Depending on the particular application, converters may require optional components. For more information about optional components, refer to Section "Optional components (Page 32)".





## Wiring

### 4.1 Line supply and motor



#### **! WARNING**

##### **Electric shock when the motor terminal box is open**

As soon as the converter is connected to the line supply, the motor connections of the converter may carry dangerous voltages. When the motor is connected to the converter, there is danger to life through contact with the motor terminals if the motor terminal box is open.

- Close the motor terminal box before connecting the converter to the line supply.

#### **Note**

##### **Fault protection for the motor circuit**

The electronic overcurrent trip complies with the requirements laid down in IEC 60364-3-2:2005/AMD1:- Section 411 for protection against electric shock.

- Observe the installation specifications provided in this manual.
- Observe the applicable installation standards.
- Ensure the continuity of the protective conductor.

#### 4.1.1 Permissible line supplies

##### 4.1.1.1 TN system

#### Overview

Example: Separate transfer of N and PE, grounded neutral point

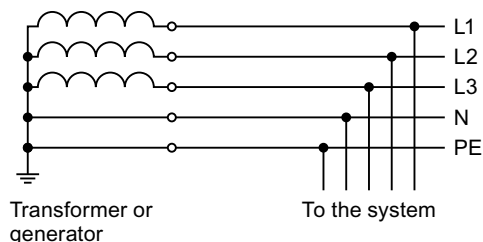

Figure 4-1 TN system

A TN system transfers the PE protective conductor to the installed plant or system using a cable.

4.1 Line supply and motor

Generally, in a TN system the neutral point is grounded. There are versions of a TN system with a grounded line conductor, e.g. with grounded L1.

The TN system can transfer the neutral conductor N and the PE protective conductor either separately or combined.

Function description

Table 4-1 Converter operated on a TN system

Converter	Line supply with grounded neutral									Line supply with grounded phase conductor and a voltage ≤ 600 V phase to phase								
	A	B	C	D	E	F	G	H	J	A	B	C	D	E	F	G	H	J
Without line filter	✓	✓	✓	✓	✓	✓	○	○	○	✓	✓	✓	✓	✓	✓	○	○	○
Integrated line filter C2	✓	✓	✓	✓	✓	✓	✓	○	○	-	-	-	-	-	-	✓ <sup>1)</sup>	○	○
Integrated line filter C3	○	○	○	○	○	✓	✓	✓	✓	○	○	○	○	○	-	✓ <sup>1)</sup>	✓ <sup>1)</sup>	✓ <sup>1)</sup>

✓ = Operation permissible

✓<sup>1)</sup> Operation permissible once grounding screw has been removed

If the grounding screw has been removed, the converter no longer fulfills the requirements of class C3.

- Operation not permissible

○ Converter not available

More information on removing the grounding connection in the converter:

 Removing functional grounding of the converter (Page 74)

4.1.1.2 TT system

Overview

Example: Transfer of N, grounded neutral point

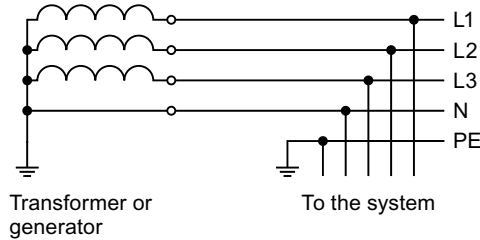

Figure 4-2 TT system

In a TT system, the transformer grounding and the installation grounding are independent of one another.

There are TT supplies where the neutral conductor N is either transferred – or not.

Function description

Note

Operation in IEC or UL systems

For installations in compliance with IEC, operation on TT systems is permissible. For installations in compliance with UL, operation on TT systems is not permissible.

Table 4-2 Converter operated on a TT system

Converter	Line supply with grounded neutral										Line supply with grounded phase conductor and a voltage ≤ 600 V phase to phase							
	A	B	C	D	E	F	G	H	J	A	B	C	D	E	F	G	H	J
Without line filter	✓	✓	✓	✓	✓	✓	○	○	○	✓	✓	✓	✓	✓	✓	○	○	○
Integrated line filter C2	✓	✓	✓	✓	✓	✓	✓	○	○	-	-	-	-	-	-	✓ <sup>1)</sup>	○	○
Integrated line filter C3	○	○	○	○	○	✓	✓	✓	✓	○	○	○	○	○	-	✓ <sup>1)</sup>	✓ <sup>1)</sup>	✓ <sup>1)</sup>

✓ = Operation permissible

✓<sup>1)</sup> Operation permissible once grounding screw has been removed

If the grounding screw has been removed, the converter no longer fulfills the requirements of class C3.

- Operation not permissible

○ Converter not available

More information on removing the grounding connection in the converter:

Removing functional grounding of the converter (Page 74)

4.1.1.3 IT system

Overview

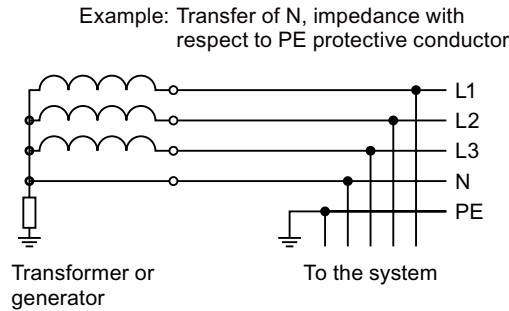

Figure 4-3 IT system

In an IT system, all of the conductors are insulated with respect to the PE protective conductor – or connected to the PE protective conductor through an impedance.

There are IT systems with and without transfer of the neutral conductor N.

Function description

Table 4-3 Converter operated on an IT system

Converter	Line supply with grounded neutral									Line supply with grounded phase conductor and a voltage ≤ 600 V phase to phase								
	A	B	C	D	E	F	G	H	J	A	B	C	D	E	F	G	H	J
Without line filter	✓	✓	✓	✓	✓	✓	○	○	○	✓	✓	✓	✓	✓	✓	○	○	○
Integrated line filter C2	-	-	-	-	-	-	-	○	○	-	-	-	-	-	-	-	○	○
Integrated line filter C3	○	○	○	○	○	-	✓ <sup>1)</sup>	✓ <sup>1)</sup>	✓ <sup>1)</sup>	○	○	○	○	○	-	✓ <sup>1)</sup>	✓ <sup>1)</sup>	✓ <sup>1)</sup>

✓ = Operation permissible

✓<sup>1)</sup> Operation permissible once grounding screw has been removed

If the grounding screw has been removed, the converter no longer fulfills the requirements of class C3.

- Operation not permissible

○ Converter not available

More information on removing the grounding connection in the converter:

Removing functional grounding of the converter (Page 74)

4.1.1.4 Removing functional grounding of the converter

If you wish to use the converters with C2/C3 line filter, note the information in the following sections:

TN system (Page 71)

 TT system (Page 73)

 IT system (Page 74)

## Precondition

Switch off the converter power supply before removing the functional grounding.



### WARNING

#### Electric shock as a result of a residual charge in power components

After the power supply has been switched off, it takes up to 5 minutes until the capacitors in the converter have discharged so that the residual charge is at a non-hazardous level. Therefore, touching the converter immediately after powering off can result in electric shock due to residual charge in the power components.

- Check the voltage at the converter connections before you remove the functional grounding.

## Removing screw for functional grounding, FSG

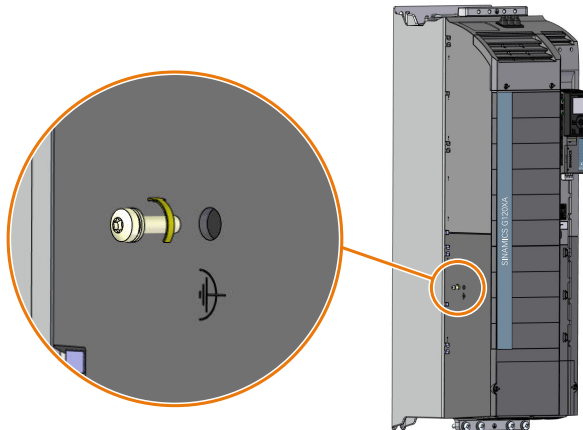

## Disconnecting the basic interference suppression module, FSH/FSJ

If a converter FSH or FSJ is operated from a non-grounded line supply (IT system), the connection to the basic interference suppression module of the Power Module must be opened.

### Procedure

1. Open the left-hand housing flap of the converter by rotating latch ①.
2. Release the two captive screws ③ and ④.
3. Release the screws ②, ⑤, and ⑥, but do not remove the screws.

4.1 Line supply and motor

4. Swivel the connection clip around the axis of rotation of screw ⑤ towards the right, until the connection clip can be fastened using screw ⑥.
5. Tighten the screws ②, ⑤, and ⑥ with 6 Nm.

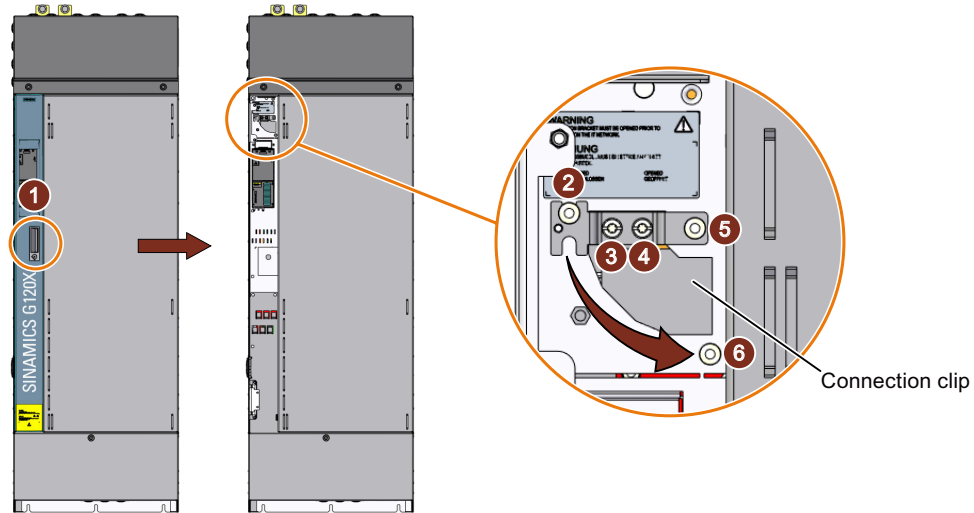

You have disconnected the basic interference suppression module.



**NOTICE**

**Device damage due to not removing the connection clip with a non-grounded line supply**

When operating a converter FSH or FSJ on a non-grounded line supply (IT system), failure to open the connection to the basic interference suppression module can cause significant damage to the device.

- With a non-grounded line supply (IT system), open the connection to the basic interference suppression module.

4.1.2 Minimum cross-section of the protective conductor

Overview

A high leakage current flows through the protective conductor in converter operation. The protective conductor of the converter must not be interrupted for safe touch protection in converter operation.

This primarily results in requirements for the minimum conductor cross-section of the protective conductor.

No restriction applies to the length of the protective conductor for touch protection. However, short protective conductors are advantageous for EMC-compliant installation.

## Description

**⚠ WARNING**
**Electric shock due to interrupted protective conductor**

The drive components conduct a high leakage current via the protective conductor. Touching conductive parts when the protective conductor is interrupted can result in death or serious injury.

- Observe the minimum cross-section of the protective conductor.

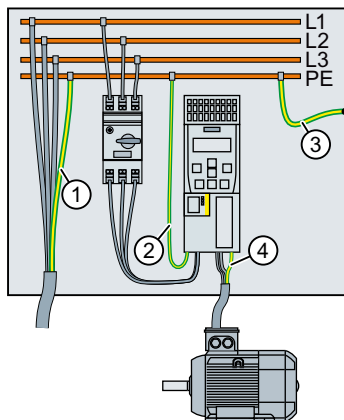

- ① Protective conductor for line feeder cables
- ② Protective conductor for converter line feeder cables
- ③ Protective conductor between PE and the control cabinet
- ④ Protective conductor for motor feeder cables

The minimum cross-section of the protective conductor ① ... ④ depends on the cross-section of the line or motor feeder cable:

- Line or motor feeder cable  $\leq 16 \text{ mm}^2$   
 ⇒ Minimum cross-section of the protective conductor = cross-section of the line or motor feeder cable
- $16 \text{ mm}^2 < \text{line or motor feeder cable} \leq 35 \text{ mm}^2$   
 ⇒ Minimum cross-section of the protective conductor =  $16 \text{ mm}^2$
- Line or motor feeder cable  $> 35 \text{ mm}^2$   
 ⇒ Minimum cross-section of the protective conductor =  $\frac{1}{2}$  cross-section of the line or motor feeder cable

Additional requirements placed on the protective conductor ①:

- For permanent connection, the protective conductor must fulfill at least one of the following conditions:
  - The protective conductor is routed so that it is protected against damage along its complete length.  
Cables routed inside switch cabinets or enclosed machine housings are considered to be adequately protected against mechanical damage.
  - As a conductor of a multi-conductor cable, the protective conductor has a cross-section  $\geq 2.5 \text{ mm}^2 \text{ Cu}$ .
  - For an individual conductor, the protective conductor has a cross-section  $\geq 10 \text{ mm}^2 \text{ Cu}$ .
  - The protective conductor consists of 2 individual conductors with the same cross-section.
- When connecting a multi-core cable using an industrial plug connector according to EN 60309, the protective conductor must have a cross-section of  $\geq 2.5 \text{ mm}^2 \text{ Cu}$ .
- Observe the local regulations for protective conductors subject to a high leakage current at the installation site.

### 4.1.3 Maximum permissible motor cable length

#### Overview

The longer the motor cable of the converter, the higher the line capacitances of the motor cable. Line capacitances cause an additive current in converter operation and present an additional load to the converter.

Therefore, a maximum admissible motor cable length is specified for each converter.

Options between converter and motor, e.g. output reactors, partially compensate for the line capacitances. Certain options make the use of longer motor cables possible.

If you must achieve compliance with an EMC category, additional restrictions apply to the motor cable length in order to control conducted emissions.

#### 400 V converter

##### EMC category according to EN 61800-3

Shielded motor cables and EMC-compliant installation are required in order to satisfy an EMC category.



 EMC-compliant setup of the machine or plant (Page 48)

Table 4-4 Maximum permissible motor cable length depending on EMC category <sup>1)</sup>

				Converter frame size 400 V	Maximum motor cable length	
First environment		C1	Converters with external C1 filter	FSA ... FSC	50 m	
				FSD	10 m <sup>4)</sup>	
				FSE	20 m <sup>4)</sup>	
				FSF	10 m <sup>4)</sup>	
Second environment	C2	Converters with integrated C2 filter	FSA ... FSC	150 m		
			FSD ... FSG	150 m <sup>2)</sup>		
		C3	Converters with integrated C3 filter	FSA ... FSC	150 m	
				FSD ... FSG	200 m	
				FSH ... FSJ	150 m <sup>3)</sup>	
				Converters without line filters with external C3 filter	FSA ... FSG	50 m

<sup>1)</sup> The values apply to a pulse frequency at the factory setting. If you set other pulse frequencies, you must ensure that the EMC category is complied with on the plant or system side.

<sup>2)</sup> 2 kHz pulse frequency for FSF, 75 kW and 90 kW

<sup>3)</sup> For motor cable lengths of 100 m ... 150 m with additional basic interference suppression module (available on request)

<sup>4)</sup> Additional installation of ferrite sleeves required

To meet the requirements of conducted emissions in accordance with C1, you must observe the maximum motor cable length and also install ferrite sleeves on the FSD ... FSF converter.

Converter frame size 400 V	Ferrite sleeve	Installation
FSD	Schaffner RU41572-1	1 ferrite sleeve per line terminal L1, L2 and L3
FSE	Schaffner VAC W517-02	1 ferrite sleeve per motor terminal U2, V2 and W2
FSF	Schaffner RU41572-2	2 ferrite sleeves per line terminal L1, L2 and L3 and 2 ferrite sleeves per motor terminal U2, V2 and W2

Install the ferrite sleeves as closely as possible to the converter terminals on the connecting cables.

4.1 Line supply and motor

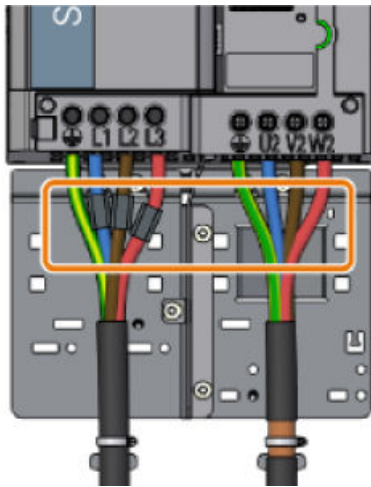

Figure 4-4 Ferrite sleeves on the connecting cables

**Without EMC category**

Table 4-5 Maximum permissible motor cable length <sup>1)</sup>

		Converter frame size 400 V	Maximum motor cable length	
With shielded motor cable	Without output reactor or dv/dt filter	FSA ... FSC	150 m	
		FSD ... FSE	200 m	
		FSF ... FSG	300 m	
		FSH ... FSJ	150 m	
	With 2 output reactors in series	FSD ... FSE	350 m	
		FSF ... FSG		525 m
	With 1 output reactor	FSH ... FSJ	300 m	
	With dv/dt filter	FSD ... FSE	350 m	
		FSF ... FSG		650 m
		FSH ... FSJ	300 m	
With unshielded motor cable	Without output reactor or dv/dt filter	FSA ... FSC	300 m	
		FSD ... FSE	300 m	
		FSF ... FSG		450 m
		FSH ... FSJ	200 m	
	With 2 output reactors in series or dv/dt filter	FSD ... FSE		525 m
		FSF ... FSG		800 m
	With 1 output reactor or dv/dt filter	FSH ... FSJ	450 m	

<sup>1)</sup> The values are valid for a pulse frequency set at the factory

## 690 V converter

**EMC category according to EN 61800-3**

Shielded motor cables and EMC-compliant installation are required in order to satisfy an EMC category.

 EMC-compliant setup of the machine or plant (Page 48)

Table 4-6 Maximum permissible motor cable length depending on EMC category <sup>1)</sup>

			Converter frame size 690 V	Maximum motor cable length	
Second environment	C2	Converters with integrated filter	FSD ... FSE	100 m	
		C3	Converters with integrated filter	FSD ... FSE	150 m
	FSF ... FSG			150 m	
	FSH ... FSJ			150 m <sup>3)</sup>	
		Converters without line filters with external C3 filter	FSD ... FSG	50 m	

<sup>1)</sup> The values are valid for a pulse frequency set at the factory

<sup>2)</sup> Operation in first environment, C2 only with external C2 line filter plus line reactor

<sup>3)</sup> For motor cable lengths of 100 m ... 150 m, an additional basic interference suppression module shall be provided on the line side (available on request).

**Without EMC category**

Table 4-7 Maximum permissible motor cable length <sup>1)</sup>

		Converter frame size 690 V	Maximum motor cable length		
With shielded motor cable	Without output reactor or dv/dt filter	FSD 18.5 kW ... 30 kW	200 m		
		FSD 37 kW ... FSG	300 m		
		FSH ... FSJ	150 m		
	With 2 output reactors in series	FSD 18.5 kW ... 30 kW	350 m		
		FSD 37 kW ... FSG	525 m		
	With 1 output reactor	FSH ... FSJ	300 m		
	With dv/dt filter	FSD 18.5 kW ... 30 kW	350 m		
		FSD 37 kW ... FSG	450 m <sup>2)</sup>	650 m <sup>3)</sup>	
		FSH ... FSJ	300 m		

4.1 Line supply and motor

		Converter frame size 690 V	Maximum motor cable length	
With unshielded motor cable	Without output reactor or dv/dt filter	FSD 18.5 kW ... 30 kW	300 m	
		FSD 37 kW ... FSG	450 m	
		FSH ... FSJ	200 m	
	With 2 output reactors in series	FSD 18.5 kW ... 30 kW	525 m	
		FSD 37 kW ... FSG	800 m	
	With 1 output reactor	FSH ... FSJ	450 m	
	With dv/dt filter	FSD 18.5 kW ... 30 kW	525 m	
		FSD 37 kW ... FSG	625 m <sup>2)</sup>	
		FSH ... FSJ	450 m	800 m <sup>3)</sup>

- 1) The values are valid for a pulse frequency set at the factory
- 2) At a maximum voltage of 1350 V at the motor terminals
- 3) At a maximum voltage of 1500 V at the motor terminals

**More information**

The permissible length of the motor cable also depends on the quality of the motor cable and the pulse frequency. The above values apply to high-quality cables, e.g. CY100.

Dimension the motor cable such that the resistance losses are less than 5% of the rated converter power.

**See also**

Electromagnetic compability of the converter (Page 914)

## 4.1.4 Connecting the converter and converter components

### 4.1.4.1 Connection overview

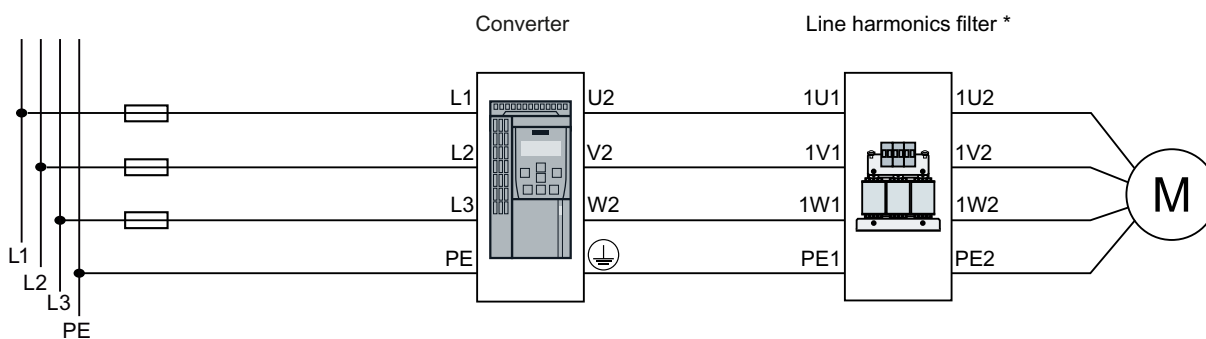

\* Line harmonics filter is only applicable to converter 400 V, FSB/FSC.

Figure 4-5 Connecting converters FSA ... FSC and their optional components

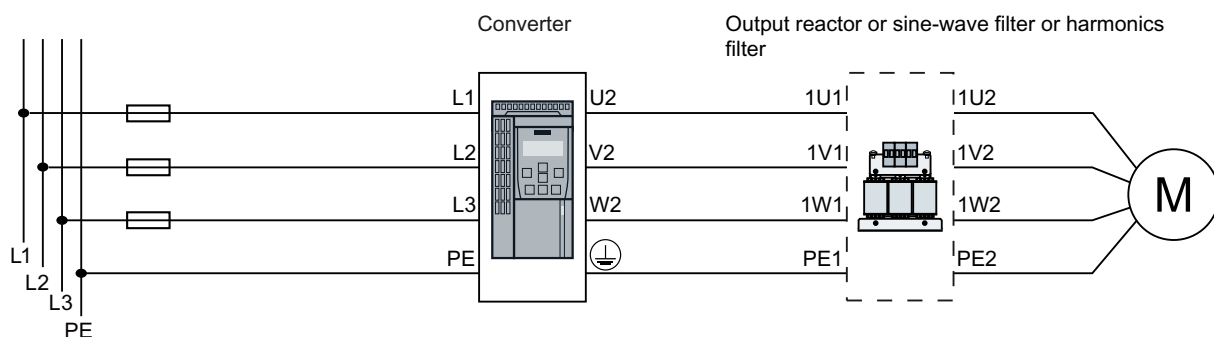

Figure 4-6 Connecting 400 V converters FSD...FSG and their optional components

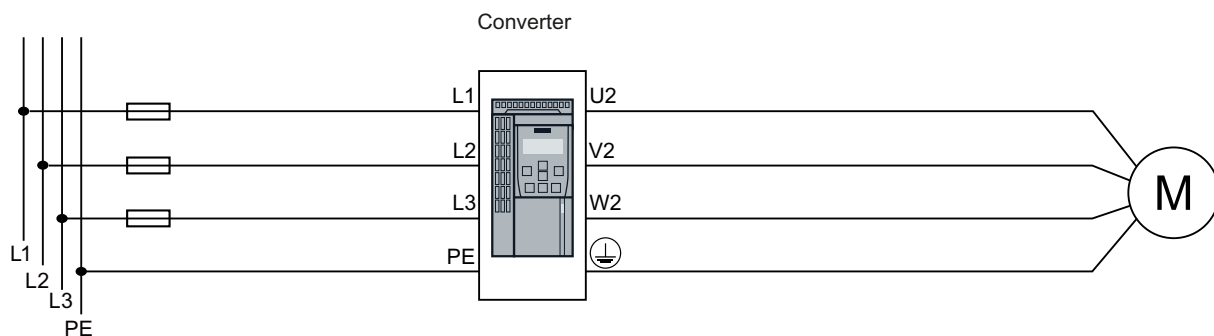

Figure 4-7 Connecting 690 V converters FSD...FSG and their optional components

4.1 Line supply and motor

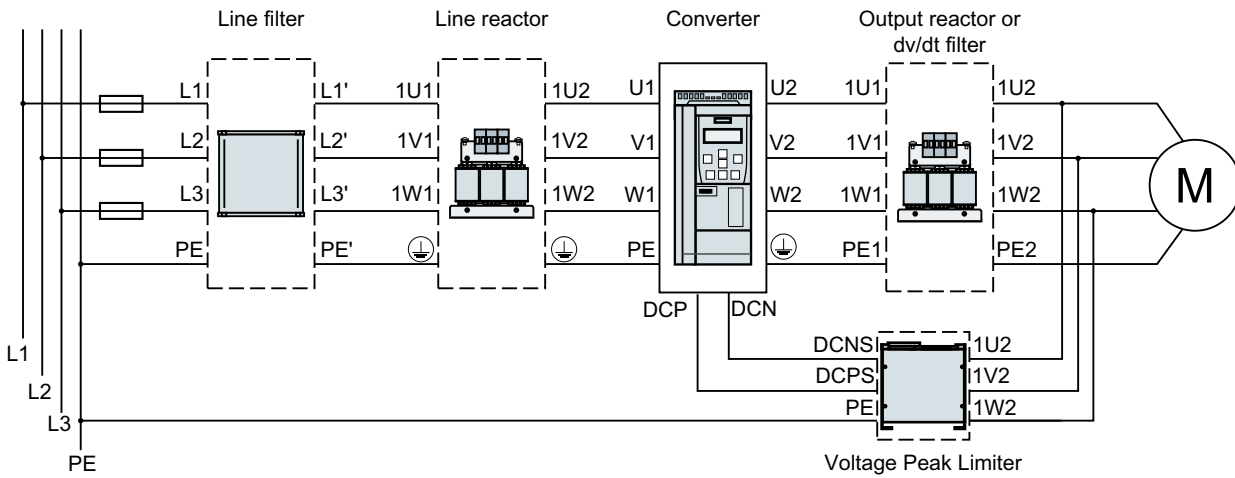

Figure 4-8 Connecting converters FSH/FSJ and their optional components

4.1.4.2 Connecting converters

**Note**

For converters of frame sizes FSA ... FSG, the R1/R2 and F3 terminals are reserved for future use.

Connecting converters, FSA ... FSC

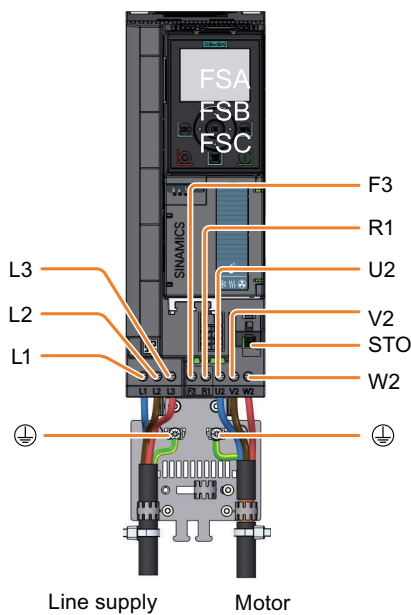

Figure 4-9 Connections for the line supply, motor and DC link terminals

## Connecting converters, FSD ... FSG

You must remove the connection cover from the converter in order to connect the line supply and motor to the converter.

- For FSD/FSE, remove the connection cover as shown below:

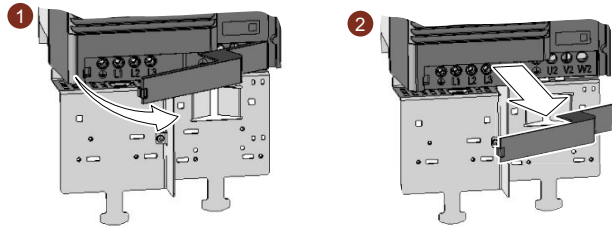

Figure 4-10 Removing the connection cover, FSD/FSE

- For FSF/FSG, remove the two screws from the cover and then remove it. In addition, you must make openings on the connection cover for the line supply and power cables. Use side cutters or a fine saw blade.

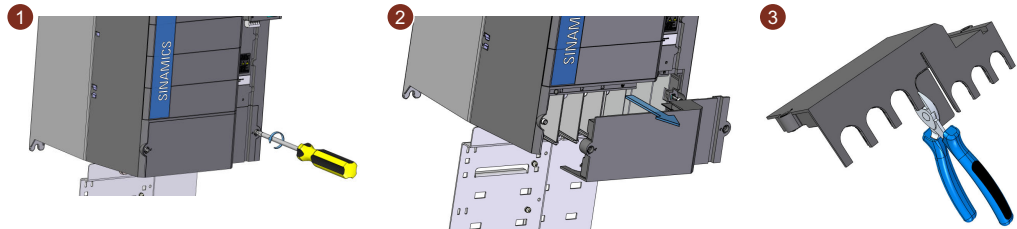

Figure 4-11 Removing the connection cover and making openings, FSF/FSG

After the cables are connected, you must re-attach the cover in order to re-establish the touch protection of the converter.

4.1 Line supply and motor

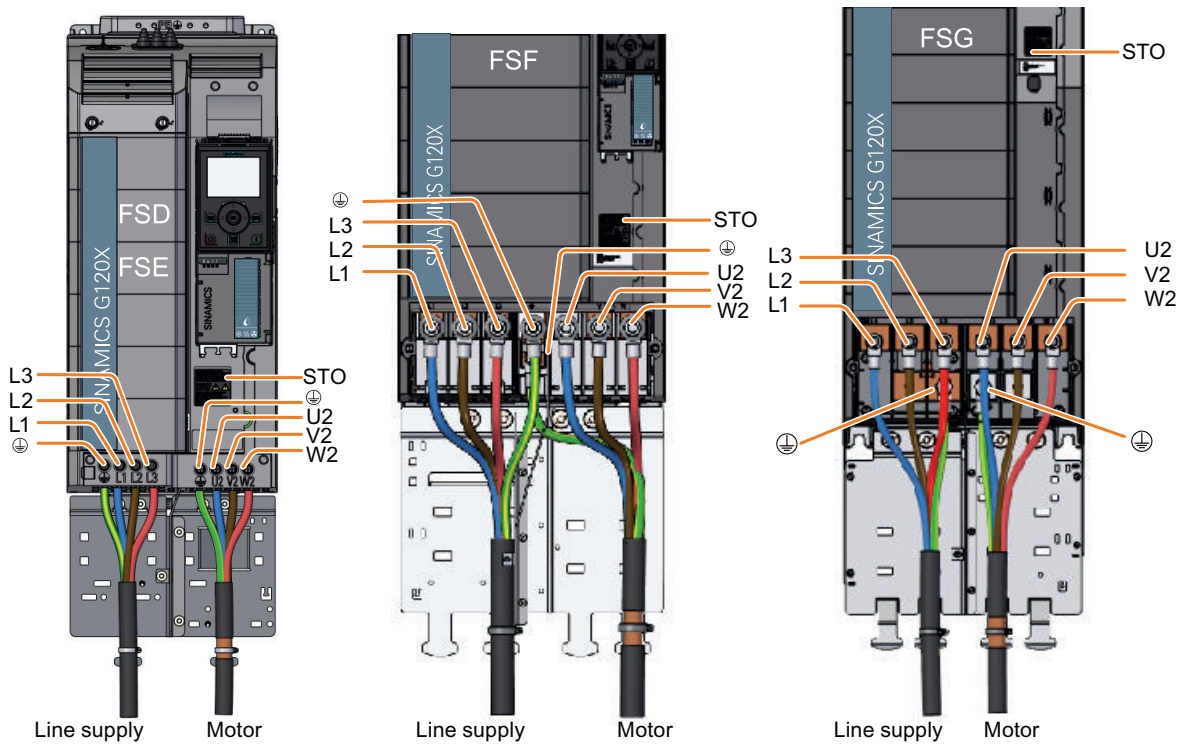
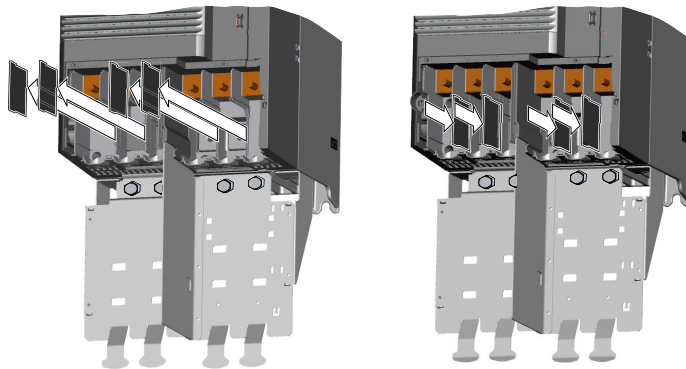



Figure 4-12 Connections for the line supply and motor

**Additional information when connecting FSG converters**

Remove the plastic insulating plate as shown below to gain better access to the terminals for the power connections.



 <b>WARNING</b>
<p><b>Damage to converter as a result of operation without insulating plates</b></p> <p>Without the insulating plates, voltage flashovers may occur between the phases.</p> <ul style="list-style-type: none"> <li>• Replace the insulating plates after connecting the cables.</li> </ul>



### Connecting converters, FSH/FSJ

To access the line and motor terminals, release the screws (three screws on FSH, and four screws on FSJ) from the front cover, and remove the cover towards the front.

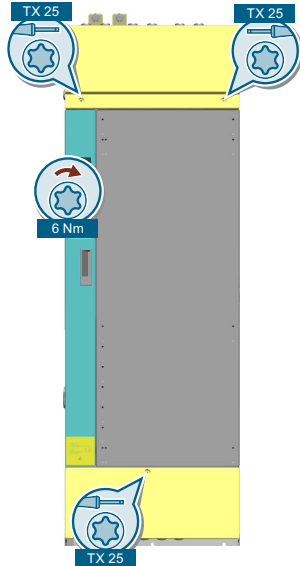

Figure 4-13 Removing the front cover

The diagram shows the layout of line and motor terminals and DC link terminals. For converter FSH, you must make openings on the cable entry protection cover for the line and motor connections according to the diameter of the cable to be introduced.

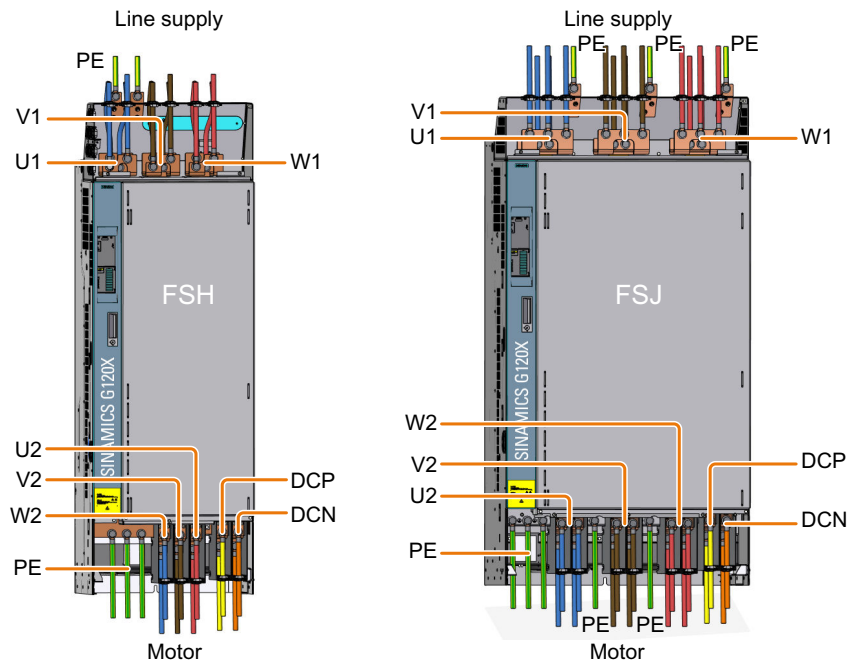

Figure 4-14 Connections for the line supply, motor and DC link terminals

4.1 Line supply and motor

Rules for connecting the line:

- Only use the front connections.
- You may connect 1 or 2 cables to each of the screws of the line connections.

Rules for connecting the motor:

- First use the front connections.
- If you use more than one cable per connection: Distribute the cables per connection evenly on the left and right side of the connection.
- Only use the rear connections when the front connections are occupied.

After the cables are connected, you must re-attach the covers in order to re-establish the touch protection of the converter (screw tightening torque: 6 Nm/53 lbf.in).



**⚠ WARNING**

**Electric shock if the cable entry protection cover is not cut correctly**

A cable entry protection cover which is not cut correctly may lead to dangerous touch voltage which can result in serious injury or death.

- Make proper openings on the cover according to the required cable diameter in order to ensure degree of protection IP20.



**⚠ WARNING**

**Electric shock due to no prevention from touching the power connection terminals**



No cable entry protection is available for frame size J which may lead to dangerous touch voltage.

- The converter must be built in an enclosure of degree of protection IP20 at least, and prevention measures against electric shock must be adopted.

4.1.4.3 Cable cross-sections and screw tightening torques

Converter frame size	Terminal/connector type		Cable cross-section	Screw tightening torque	Stripped insulation length
FSA	Line, motor and PE	Screw-type terminal	1.5 ... 2.5 mm <sup>2</sup> , 16 ... 14 AWG	0.5 Nm, 4.4 lbf.in	9 ... 10 mm
FSB			1.5 ... 6 mm <sup>2</sup> , 16 ... 10 AWG	1.3 Nm, 11.5 lbf.in	12 ... 13 mm
FSC			1.5 ... 16 mm <sup>2</sup> , 16 ... 6 AWG	1.3 Nm, 11.5 lbf.in	12 ... 13 mm
FSD			10 ... 35 mm <sup>2</sup> , 8 ... 2 AWG	4.5 Nm, 39.8 lbf.in	18 mm
FSE			25 ... 70 mm <sup>2</sup> , 4 ... 3/0 AWG	10 Nm, 88.5 lbf.in	25 mm

Converter frame size	Terminal/connector type		Cable cross-section	Screw tightening torque
FSF	Line, motor and PE	 Cable lug according to SN71322 for M10 bolts	35 mm <sup>2</sup> ... 2 × 120 mm <sup>2</sup> 2 ... 2 × 4/0 AWG	22 ... 25 Nm 194.7 ... 221.3 lbf.in
FSG			35 mm <sup>2</sup> ... 2 × 185 mm <sup>2</sup> 2 ... 2 × 350 MCM	50 Nm 442.5 lbf.in

Converter frame size	Terminal/connector type		Cable cross-section			Screw tightening torque		
FSH	Line, motor and DC	 Cable lug according to DIN 46234 for M12 screws <sup>1)</sup>	Max.	4 × 240 mm <sup>2</sup> , 4 × 500 MCM		50 Nm 442.5 lbf.in		
				Recommended	315 kW		@ 400 V	@ 480 V
			Line 2 × 240 mm <sup>2</sup>				2 × 185 mm <sup>2</sup>	
			Motor 2 × 185 mm <sup>2</sup>				2 × 150 mm <sup>2</sup>	
			355 kW		DC 2 × 185 mm <sup>2</sup>		2 × 150 mm <sup>2</sup>	
					Line 3 × 150 mm <sup>2</sup>		2 × 240 mm <sup>2</sup>	
					Motor 2 × 240 mm <sup>2</sup>		2 × 185 mm <sup>2</sup>	
			400 kW		DC 2 × 240 mm <sup>2</sup>		2 × 185 mm <sup>2</sup>	
					Line 3 × 185 mm <sup>2</sup>		2 × 240 mm <sup>2</sup>	
					Motor 2 × 240 mm <sup>2</sup>		2 × 240 mm <sup>2</sup>	
FSJ	Line, motor and DC	 Cable lug according to DIN 46234 for M12 screws <sup>1)</sup>	Max.	450 kW ... 560 kW		50 Nm 442.5 lbf.in		
				Recommended	450 kW		Line 6 × 240 mm <sup>2</sup> , 6 × 500 MCM	
							Motor, DC 4 × 240 mm <sup>2</sup> , 4 × 500 MCM	
							500 kW, 560 kW	Motor 8 × 240 mm <sup>2</sup> , 8 × 500 MCM
			500 kW		DC 4 × 240 mm <sup>2</sup> , 4 × 500 MCM			
					@ 400 V		@ 480 V	
					Line 4 × 185 mm <sup>2</sup>		4 × 120 mm <sup>2</sup>	
			560 kW	Motor 4 × 150 mm <sup>2</sup>	4 × 120 mm <sup>2</sup>			
				DC 4 × 120 mm <sup>2</sup>	3 × 120 mm <sup>2</sup>			
				Line 4 × 185 mm <sup>2</sup>	4 × 150 mm <sup>2</sup>			
560 kW	Motor 4 × 185 mm <sup>2</sup>	4 × 150 mm <sup>2</sup>						
	DC 4 × 150 mm <sup>2</sup>	3 × 150 mm <sup>2</sup>						
	Line 4 × 240 mm <sup>2</sup>	4 × 185 mm <sup>2</sup>						
560 kW	Motor 4 × 240 mm <sup>2</sup>	4 × 150 mm <sup>2</sup>						
	DC 4 × 185 mm <sup>2</sup>	3 × 185 mm <sup>2</sup>						
	Line 4 × 185 mm <sup>2</sup>	3 × 185 mm <sup>2</sup>						

<sup>1)</sup> Alternative copper busbars can be used for line and motor connections. Make sure that you use copper busbars of the same cross-sections as the connecting busbars of the converter itself (FSH: 64 mm × 8 mm; FSJ: 80 mm × 8 mm).

4.1.4.4 Cable lug

For cable connections using cable lugs, the maximum dimensions of the cable lugs are listed in the table below. These cable lugs are not to exceed these dimensions, as mechanical fastening and adherence to the voltage distances is not guaranteed otherwise.

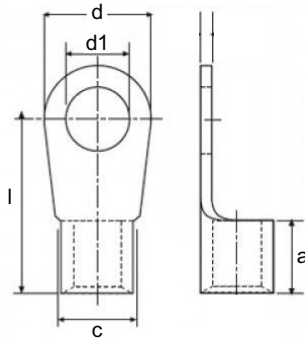

Converter frame size	Screw/bolt	Cable cross-section (mm <sup>2</sup> )	a (mm)	c (mm)	d1 (mm)	d (mm)	l (mm)
FSF	M10	120	26	22	10.5	32	59.5
FSG		185	30	27	10.5	39	72.5
FSH/FSJ	M12	240	32	23.5	13	42	92

The cable lugs can be attached as shown in the following diagram if, at one connection per phase, two cable lugs can be connected.

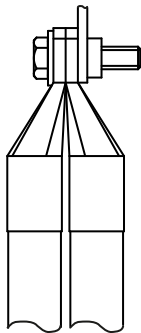

4.1.4.5 Connecting the cable shields (FSA ... FSG only)

For EMC-compliant wiring, you must connect the cable shields to the shield plate of the converter.

Use shielded cables for the following connection:

- Communication cable
- Control cable
- Motor cable

Before connecting the cable shields, you need to strip the cable insulation.

### Connecting the cable shields, FSA ... FSC converters

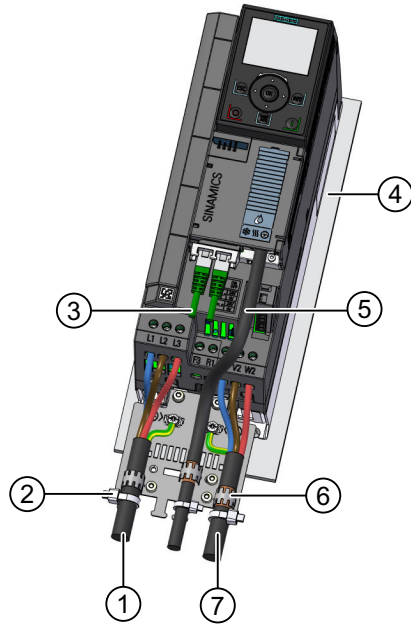

The shield support for converter FSB is displayed as an example.

- ① Unshielded line cable
- ② Cable tie
- ③ Unshielded communication cable
- ④ Unlacquered, good electrically conducting mounting plate
- ⑤ Shielded control cable
- ⑥ Toothed tape
- ⑦ Shielded motor cable

### Connecting the cable shields, FSD ... FSG converters

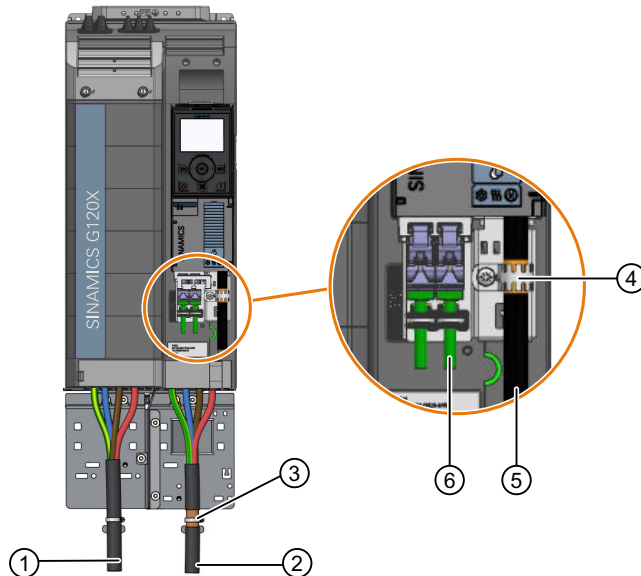

The shield support for converter FSD is displayed as an example.

- ① Unshielded line cable
- ② Shielded motor cable
- ③ Hose clamp
- ④ Toothed tape
- ⑤ Shielded control cable
- ⑥ Unshielded communication cable

---

**Note**

**Unshielded communication cable**

It is unnecessary to connect the cable shields if you use Siemens PROFINET cables for communication. When using communication cables from other manufacturers, make sure that you connect the cable shields with toothed tapes.

---

## 4.1.5 Connecting the motor to the converter in a star or delta connection

### Overview

Standard induction motors up to a rated power of approximately 3 kW are usually connected in star/delta connection (Y/ $\Delta$ ) at 400 V/230 V. For a 400-V line supply, you can connect the motor to the converter either in a star or in a delta connection.

### Function description

#### Operating the motor in a star connection

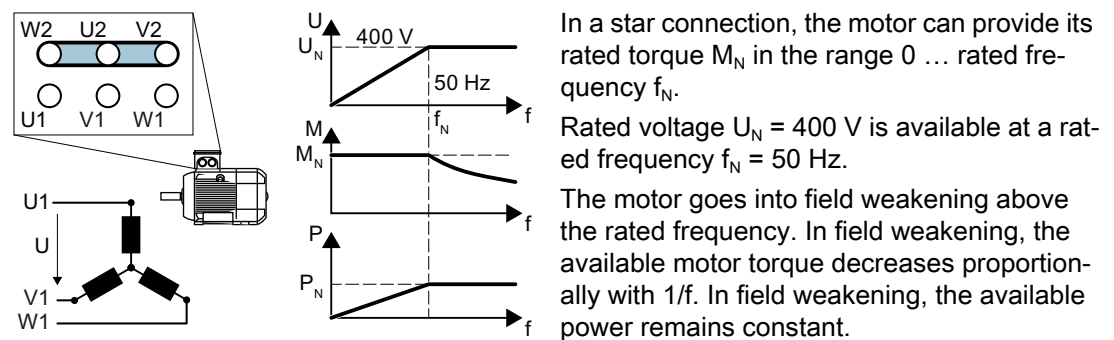

#### Operating the motor in a delta connection with 87 Hz characteristic

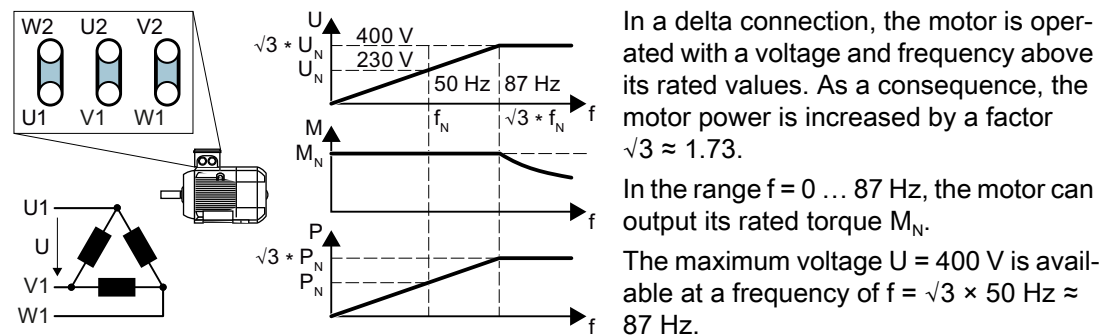

The motor only goes into field weakening above 87 Hz.

The higher motor power when operated with an 87 Hz characteristic has the following disadvantages:

- The converter must supply approximately 1.73x current. Select a converter based on its rated current - and not its rated power.
- The motor temperature increases more significantly than when operated with  $f \leq 50$  Hz.
- The motor must have windings that are approved for a voltage > rated voltage  $U_N$ .
- As the fan impeller rotates faster, the motor has a higher noise level than operation with  $f \leq 50$  Hz.

## 4.2 Control interfaces

### 4.2.1 Overview of the interfaces

#### Interfaces at the front of the Control Unit

To access the interfaces at the front of the Control Unit, you must open the front door.

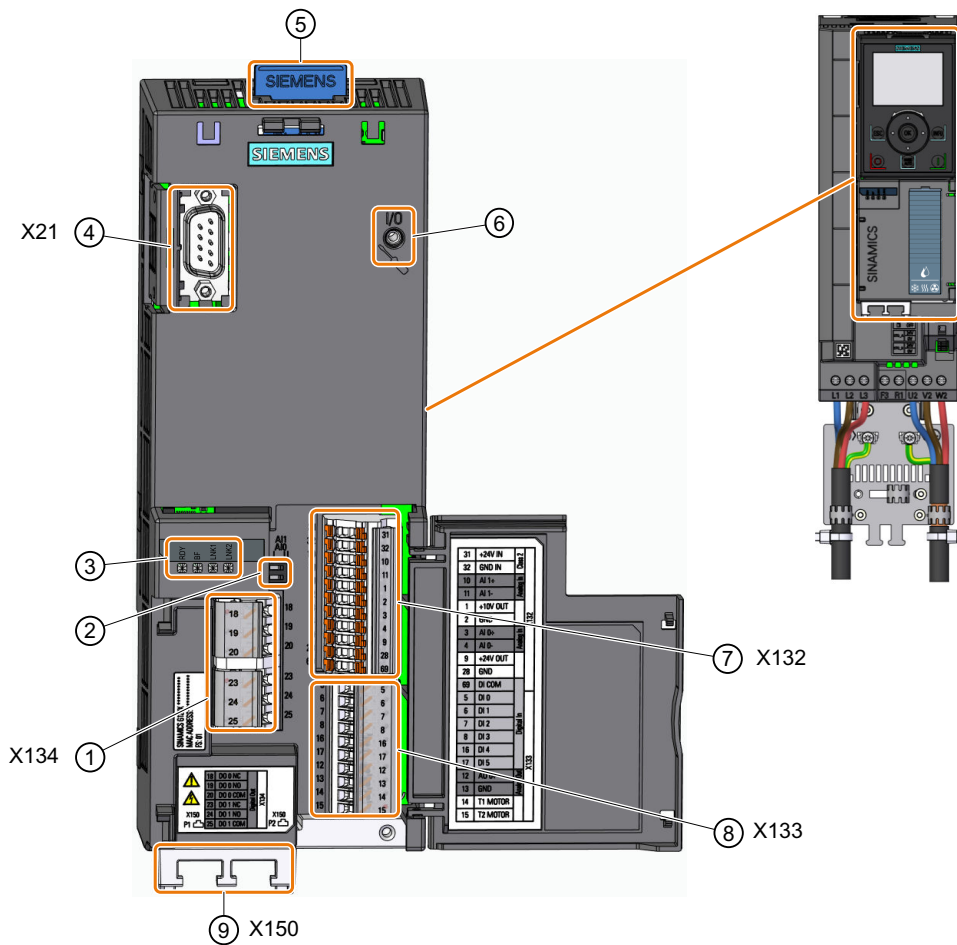

- ① Terminal strip
- ② Switch for AI 0 and AI 1 (U/I)
- ③ Status LED
- ④ Connection to the Operator Panel or Smart Access
- ⑤ Memory card slot
- ⑥ Reserved for future use

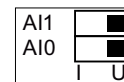



- ⑦⑧ Terminal strips
- ⑨ Fieldbus interfaces at the lower side

Table 4-8 Number of inputs and outputs

Digital inputs DI	Digital outputs DO	Analog inputs AI	Analog outputs AO	Input for motor temperature sensor
6	2	2	1	1

## 4.2.2 Fieldbus interface allocation

### Interfaces at the lower side of the Control Unit

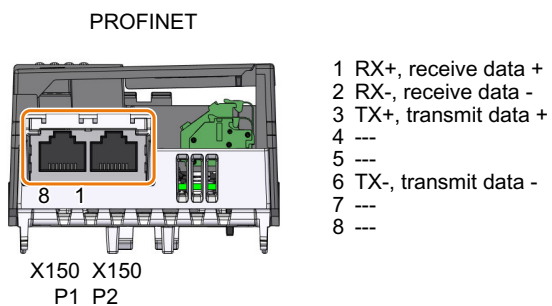

### 4.2.3 Terminal strips

#### Terminal strips with wiring example

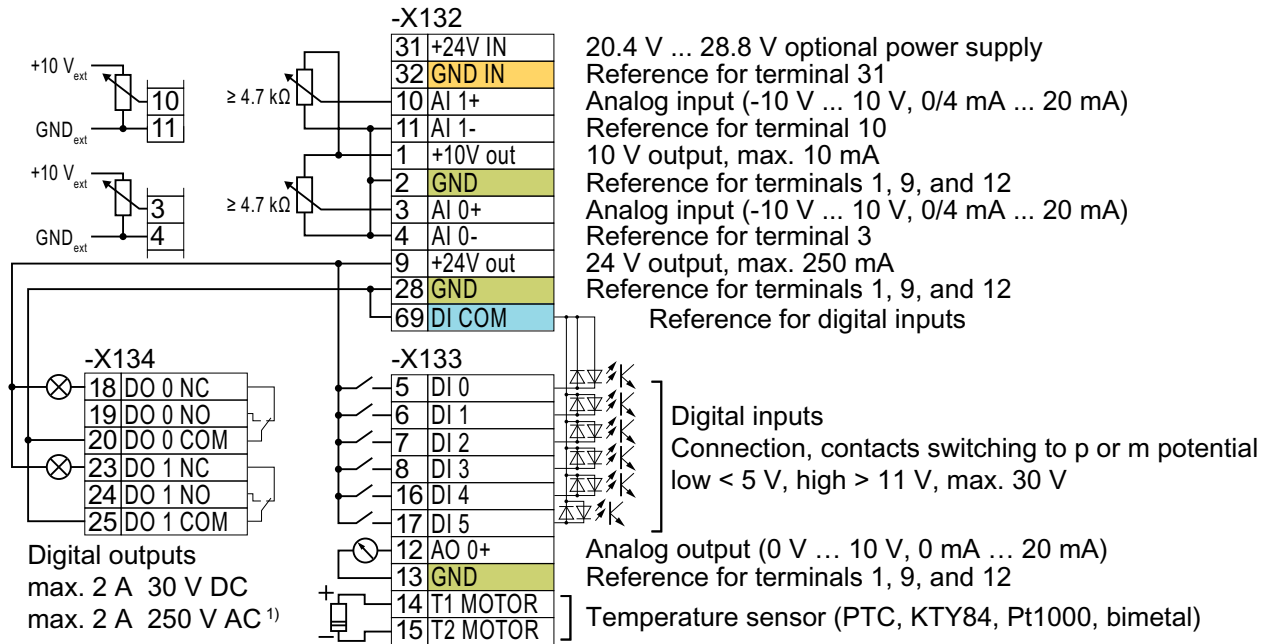

1) The digital outputs are designed for low voltage systems of overvoltage category II. In installations of overvoltage category III, galvanic isolation is required between the supply network and the digital output.

Restriction for FSB and FSC in installations compliant with UL: max. 0.5 A

Figure 4-15 Wiring the digital inputs with p-switching contacts and an internal 24 V power supply (terminal 9)

**GND**

All terminals with the "GND" reference potential are internally connected with one another.

**DI COM**

The reference potential "DI COM" is not internally connected with "GND".

→ If, as shown above, you wish to use the 24 V supply from terminal 9 as supply for the digital inputs, a jumper is required between terminals 28 and 69.

**31 +24 V IN**  
**32 GND IN**

When an optional 24 V power supply is connected at terminals 31, 32, even when the Power Module is disconnected from the line supply, the Control Unit remains in operation. The Control Unit thus maintains fieldbus communication, for example.

→ for terminals 31, 32, only use a 24 VDC power supply according to SELV (Safety Extra Low Voltage) or PELV (Protective Extra Low Voltage).

→ if you also wish to use the power supply at terminals 31, 32 for the digital inputs, then you must connect "DI COM" and "GND IN" with one another at the terminals.

**10 AI 1+**  
**11 AI 1-**  
**3 AI 0+**  
**4 AI 0-**

You may use the internal 10 V power supply or an external power supply for the analog inputs.  
→ When you use the internal 10 V power supply, you must connect AI 0 or AI 1 with "GND".

## Additional options for wiring the digital inputs

The following diagram shows how you supply the digital inputs and digital outputs with an external voltage.

If you wish to connect an external power supply with the GND potential of the converter, then you must connect terminals 28 and 69 together.

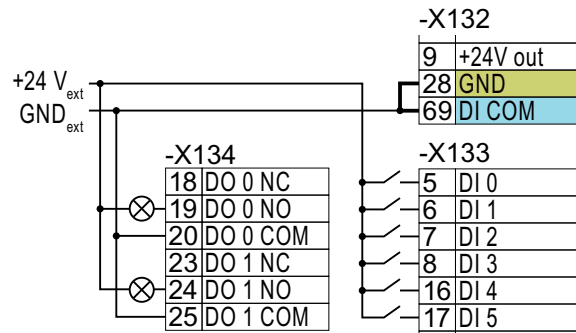

Figure 4-16 Connecting contacts switching to p potential with an external power supply

The following diagram shows how you use the digital inputs for the contacts that switch to m potential.

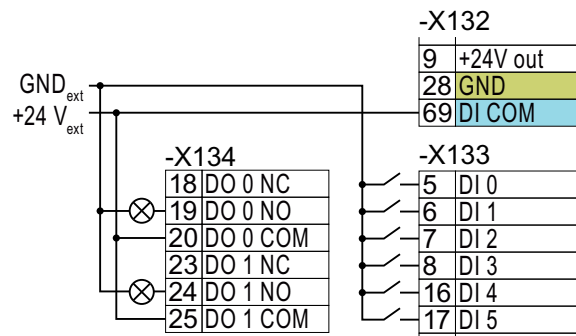

Figure 4-17 Connecting contacts switching to m potential with an external power supply



### **WARNING**

#### **Electric shock due to unsuitable power supply**

When equipment is connected to an unsuitable power supply, exposed components may carry a hazardous voltage that might result in serious injury or death.

- Only use power supplies that provide SELV (Safety Extra Low Voltage) or PELV- (Protective Extra Low Voltage) output voltages (maximum 60 V DC briefly) for all connections and terminals of the electronics modules.

**NOTICE**

**Damage when the 24V output voltage is short-circuited**

If the following conditions occur simultaneously, the Control Unit with PROFINET interface can be damaged:

1. The converter is operational.
  2. The 24V output voltage develops a short-circuit at terminal 9.
  3. The ambient temperature reaches the maximum permissible value.
  4. The external 24V power supply voltage at terminals 31 and 32 reaches the maximum permissible value.
- Ensure that not all of these conditions are simultaneously satisfied.

### 4.2.4 Factory interface settings

#### Function description

In the factory setting, the converter switches over the following functions depending on the state of digital input DI 4:

- Fieldbus interface
- Digital input DI 0
- Digital input DI 1
- Speed setpoint

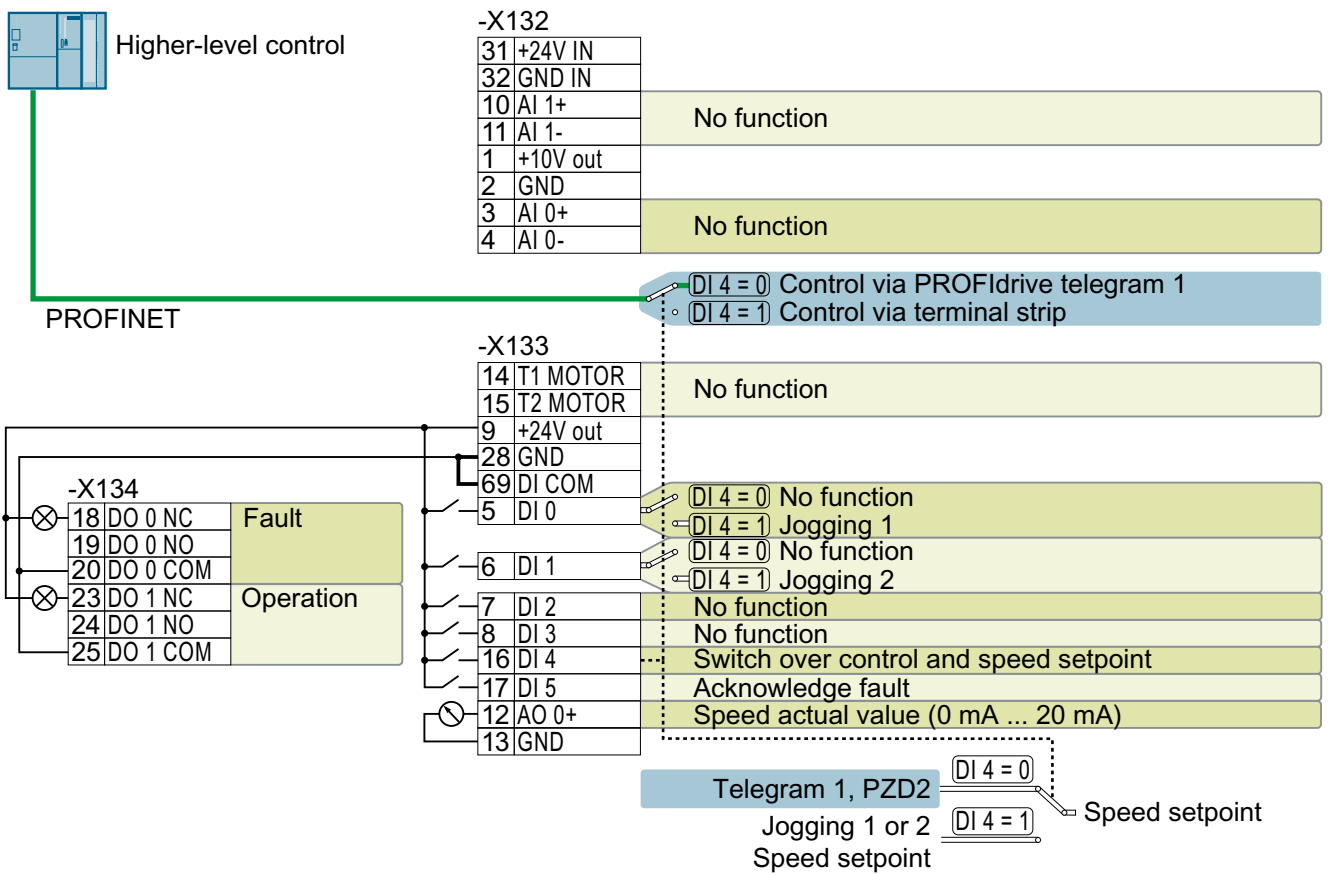

Figure 4-18 Factory interface settings

### 4.2.5 Default setting of the interfaces

#### Overview

The function of most of the converter terminals can be set.

In order that you do not have to successively change terminal for terminal, several terminals can be jointly set in the quick commissioning using default settings. Parameter p0015 in the quick commissioning selects the appropriate default setting.

Table 4-9 Overview of default settings

Terminal	Default setting			
	41	42	45	57
AI 0	Setpoint	Setpoint	Setpoint	-
AI 1	-	PID actual value	-	-
AO 0	Speed actual value	Speed actual value	Speed actual value	Speed actual value
DI 0	ON/OFF2	ON/OFF2	ON/OFF2	Jogging 1
DI 1	-	-	Fixed setpoint 1	Jogging 2
DI 2	-	-	Fixed setpoint 2	-
DI 3	-	-	Fixed setpoint 3	-
DI 4	-	manual ↔ auto	-	Switch over controller: Fieldbus ↔ terminal strip
DI 5	Acknowledge fault	Acknowledge fault	Acknowledge fault	Acknowledge fault
DO 0	Fault	Fault	Fault	Fault
DO 1	Operation	Operation	Operation	Operation

#### Function description

##### Default setting 41: "Analog control"

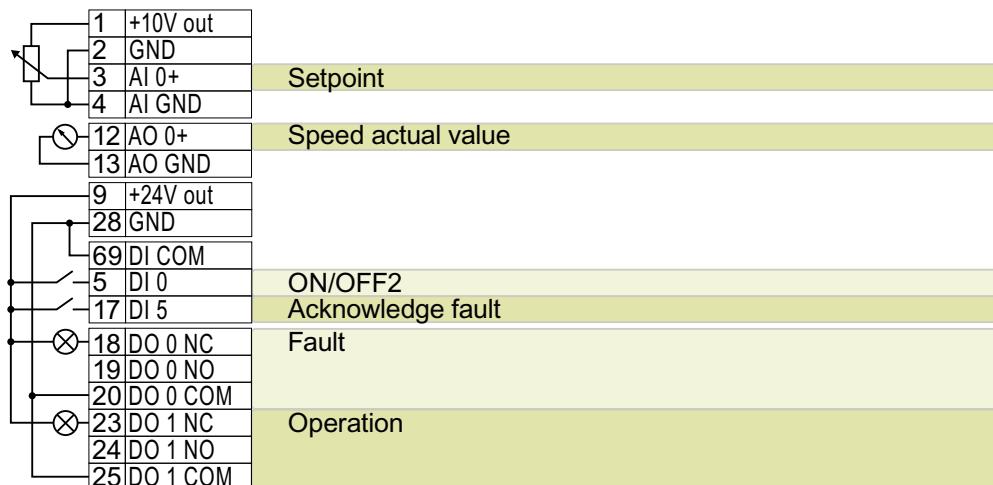

Setting	Parameter	Characteristics	Setting	Parameter
Default setting 41	p0015 = 41		DI 0	p29652[0] = 722.0
AI 0	p1070[0] = 755[0]		ON/OFF1	p29650[0] = 0
AO 0	p0771[0] = 21		OFF2	p0840[0] = 29659.0
			DI 5	p0844[0] = 29659.1
			DO 0	p2104[0] = 722.5
			DO 1	p0730 = 52.3
				p0731 = 52.2

Procedure with the BOP-2 operator panel:  
 → SETUP → ... → MAc PAr → P15 = X AI → ... → FINISH

**Default setting 42: "PID controller with analog control"**

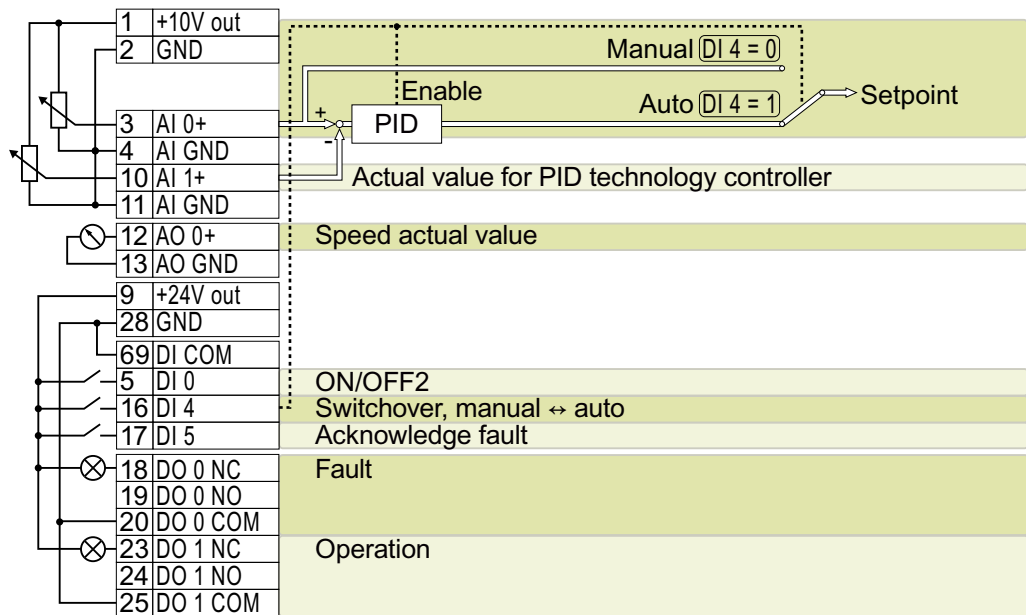

Setting	Parameter	Characteristics	Setting	Parameter
Default setting 42	p0015 = 42		DI 0	p29652[0] = 722.0
AI 0	p2253[0] = 755[0] p1070[0] = 755[0]		ON/OFF1	p29650[0] = 0
AI 1	p2264[0] = 755[1]		OFF2	p0840[0] = 29659.0
AO 0	p0771[0] = 21		DI 4	p0844[0] = 29659.1
			DI 5	p2200 = 722.4
			DO 0	p2104[0] = 722.5
			DO 1	p0730 = 52.3
				p0731 = 52.2

Procedure with the BOP-2 operator panel:  
 → SETUP → ... → MAc PAr → P15 = X AI PID → ... → FINISH

**Default setting 45: "Fixed setpoint control"**

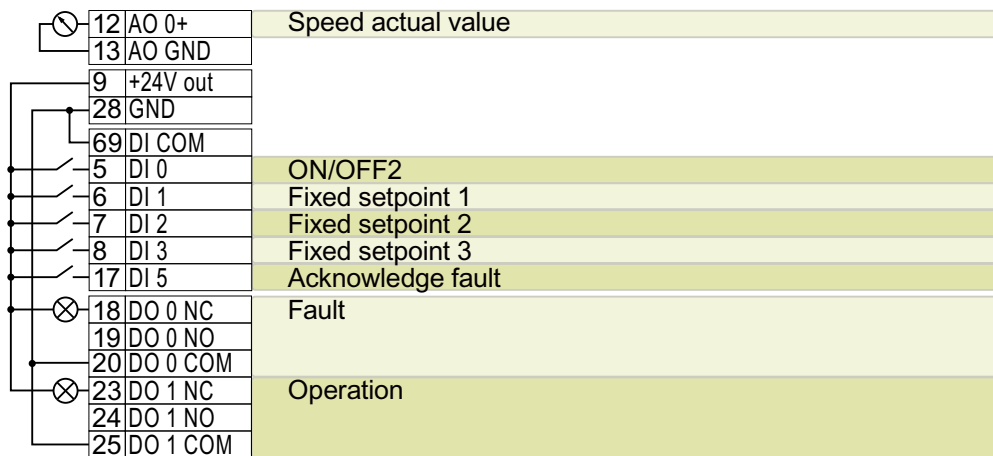

Setting	Parameter	Characteristics	Setting	Parameter
Default setting 45	p0015 = 45		DI 0	p29652[0] = 722.0
AO 0	p0771[0] = 21		ON/OFF1	p29650[0] = 0
Fixed setpoint	p1070 = 1024 p1016 = 2		OFF2	p0840[0] = 29659.0
			DI 1	p0844[0] = 29659.1
			DI 2	p1020[0] = 722.1
			DI 3	p1021[0] = 722.2
			DI 5	p1022[0] = 722.3
			DI 5	p2104[0] = 722.5
			DO 0	p0730 = 52.3
			DO 1	p0731 = 52.2

Procedure with the BOP-2 operator panel:  
 → SETUP → ... → MAc PAr → P15 = X FIX → ... → FINISH



**Default setting 57: "PROFINET control"**

"PROFINET control" is the default factory setting.

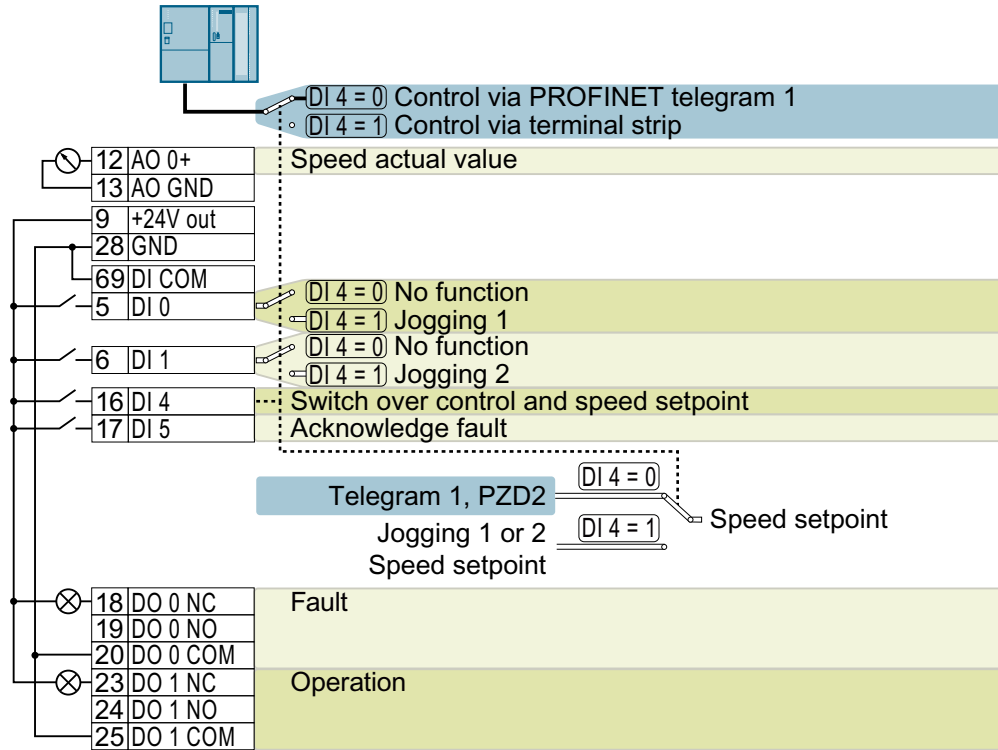

Setting	Parameter	Characteristic	Setting	Parameter
Default setting 57	p0015 = 57		DI 0	p29652[1] = 722.0 p29650[1] = 0
AO 0	p0771[0] = 21		ON/OFF1	p0840[0...1] = 29659.0
			DI 1	p0844[0...1] = 29659.1
			DI 4	p29652[0] = 722.1
			DI 5	p29650[0] = 1 p0810 = 722.4 p2104[0...1] = 722.5
PROFINET	p0922 = 1 p1070[0] = 2050[1]		DO 0	p0730 = 52.3
			DO 1	p0731 = 52.2
Procedure with the BOP-2 operator panel: → SETUP → ... → MAc PAr → P15 = X PN 1 → ... → FINISH				

**More information**

The default terminal settings can be adjusted to suit your requirements.

Adapt the default setting of the terminal strips (Page 153)

### 4.2.6 Additional digital inputs and digital outputs on converters FSH and FSJ

#### Overview

Converters FSH and FSJ have 4 additional digital inputs and 2 digital outputs at terminal strip X9.

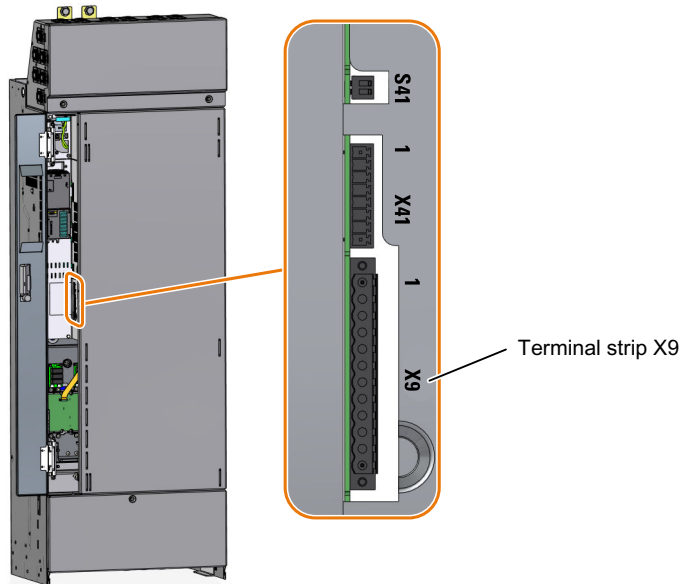
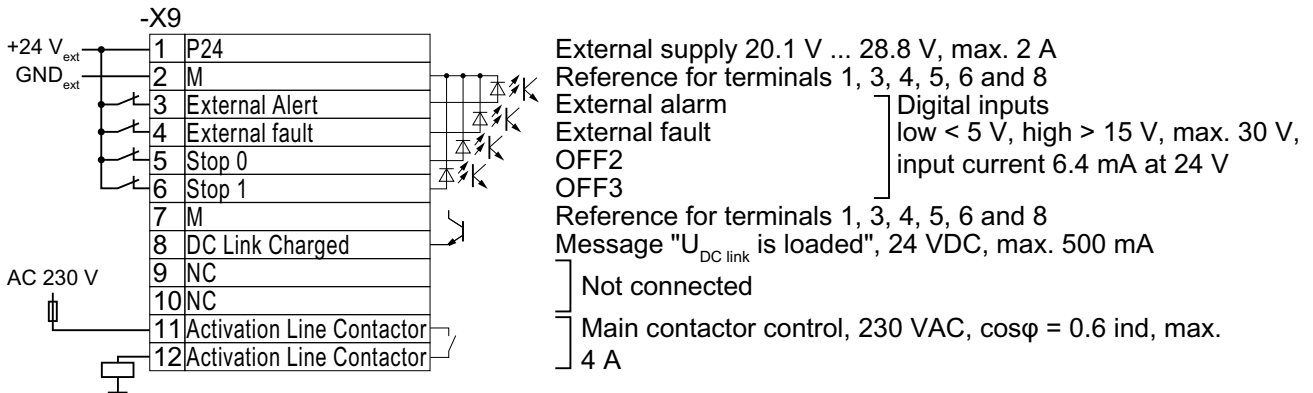

Figure 4-19 Terminal strip X9

Function description



Connection cross-section: 0.2 mm<sup>2</sup> ... 2.5 mm<sup>2</sup>, tightening torque: 0.5 Nm (5 lb.in)

Use insulated end sleeves according to DIN 46228-4.

Terminals Remark

- 1 You may either connect an external 24 V supply or use the internal 24 V supply.
- 3 ... 6 The function of the digital inputs is shown in the factory setting.  
You can change the function of the digital inputs subsequently.  
The digital inputs are low-active in the factory setting. If you do not use one of the digital inputs, you must connect the digital input with 24 V.
- 8, 11, 12 The function of the digital outputs cannot be changed.
- 8 The digital output signals a fully charged DC link of the converter. A charged DC link is the prerequisite for the "operation" converter state.
- 11, 12 A device to protect against overload and short-circuit is required for the power supply to the line contactor control, e.g. a 4 A / 250 V fuse.  
Connect the excitation coil of the line contactor to a surge suppressor, e.g. an RC element.

Figure 4-20 Terminal strip X9 with external 24 V supply

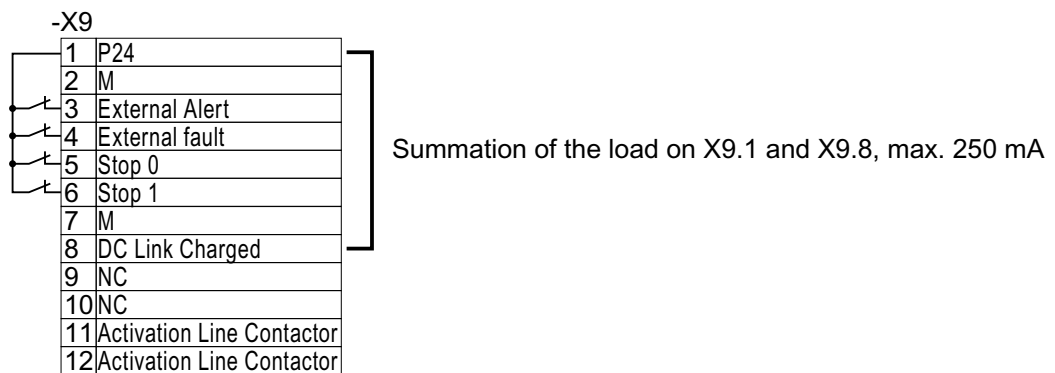

Figure 4-21 Terminal strip X9 with internal 24 V supply

## 4.2.7 "Safe Torque Off" safety function

### Overview

The "Safe Torque Off" (STO) safety function can be implemented using a failsafe digital input of the converter.

### Preconditions

- Both switches on the converter for enabling/disabling STO are in the ON position.
- The higher-level control system monitors the selection of STO and the feedback from the converter.



Application examples for "Safe Torque Off" (Page 110)

### Function description

Use an SELV or PELV power supply with 24 V DC (20.4 V ... 28.8 V, maximum 60 V briefly).

Use a shielded cable with the following properties:

- Cable length  $\leq 30$  m
- Cross section  $0.5 \text{ mm}^2 \dots + 1.5 \text{ mm}^2$  (20 ... 16 AWG)
- Insulated for 600 V
- Conductor end sleeves, stripping length 7 mm

Tightening torque: 0.2 Nm (2 lbf in)

Procedure for converters in frame sizes FSA ... FSC

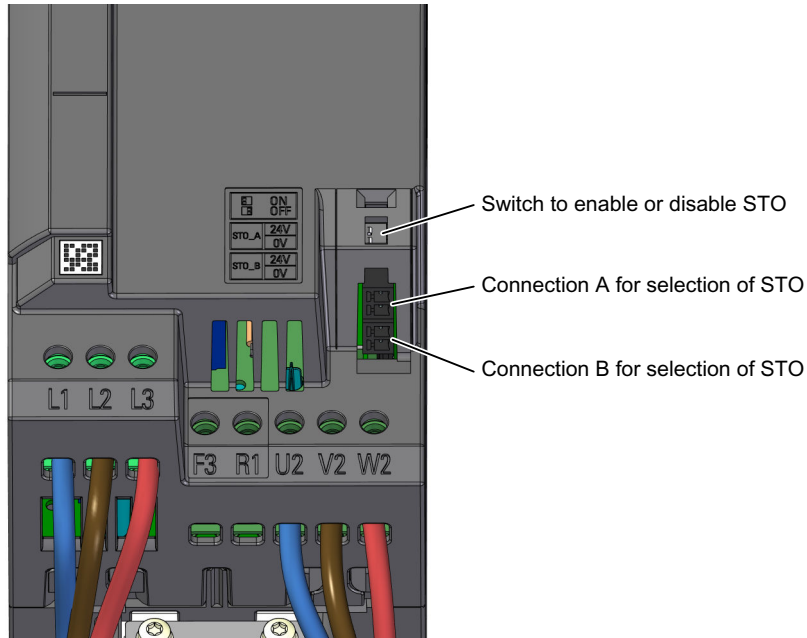

Both switches = ON: STO is enabled

Both switches = OFF: STO is locked

Two switches different: STO is disabled, the converter signals a fault.

Figure 4-22 Terminals and switches for the "STO" function, frame sizes FSA ... FSC

1. Connect the cables for selecting STO to terminals STO\_A and STO\_B.
2. Connect the cables for STO feedback to 2 digital outputs of terminal block X134.

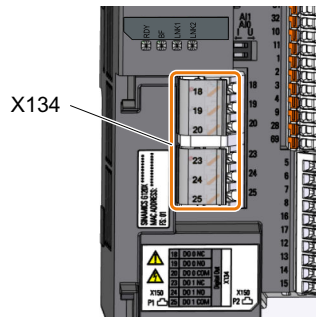

3. Attach the shield to the shield plate of the converter through the largest possible surface area.

You have connected all cables for the STO safety function.



Procedure for converters in frame sizes FSD ... FSG

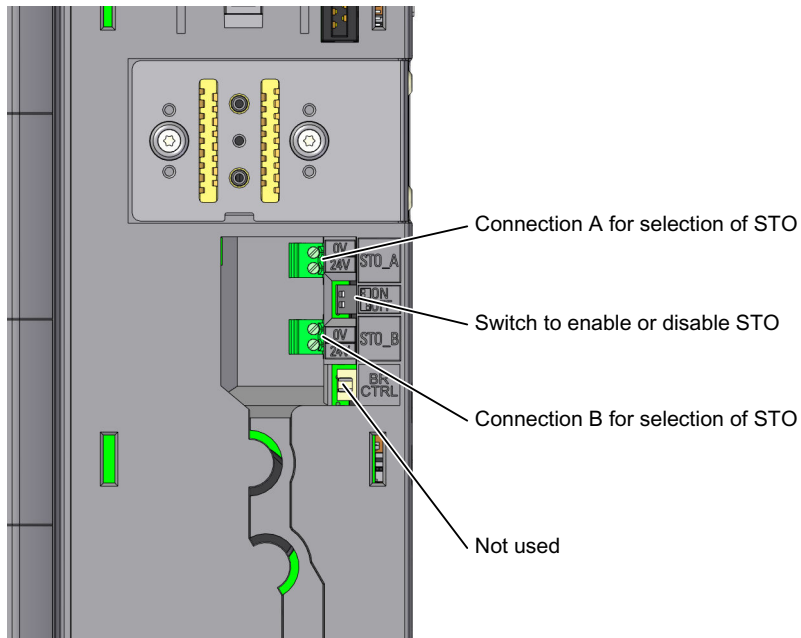

Both switches = ON: STO is enabled

Both switches = OFF: STO is locked

Two switches different: STO is disabled, the converter signals a fault.

Figure 4-23 Terminals and switches for the "STO" function, frame sizes FSD ... FSG

1. Remove the Control Unit.

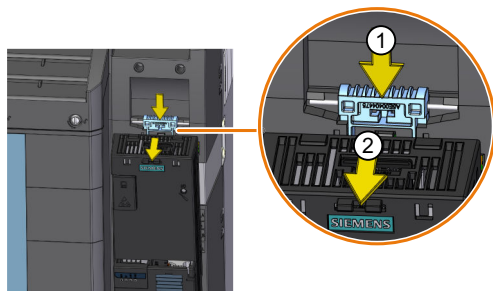

2. Connect the cable for selecting STO to terminals STO\_A and STO\_B.
3. Plug in the Control Unit.



4. Connect the cables for STO feedback to 2 digital outputs of terminal block X134.

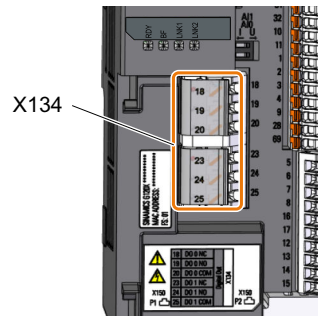

5. Attach the shield to the shield plate of the Control Unit through the largest possible surface area.

You have connected all cables for the STO safety function.



#### Procedure for converters in frame sizes FSH ... FSJ

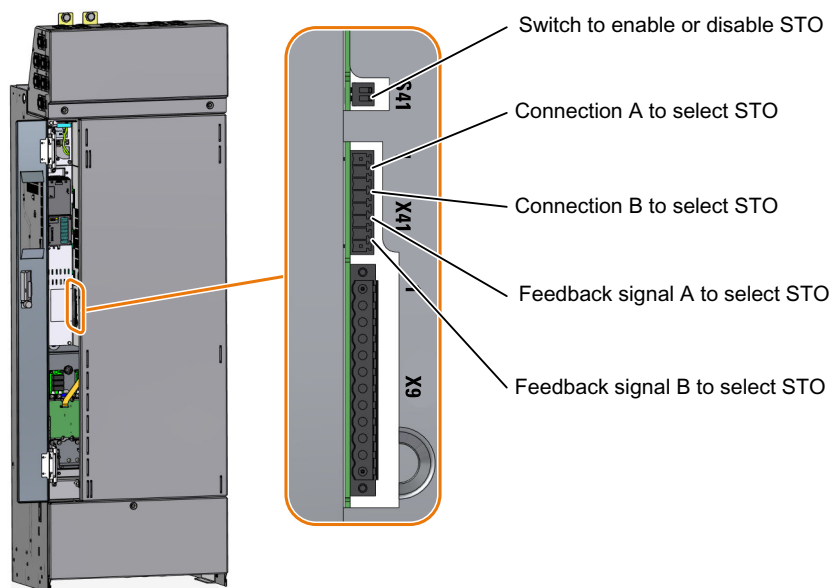

Figure 4-24 Terminals and switches for the "STO" function, frame sizes FSH and FSJ

1. Connect the cable for selecting STO to terminals X41:STO\_A and X41:STO\_B.
2. Connect the cables for STO feedback to terminals X41:FB\_A and X41:FB\_B.
3. Attach the shield to the shield plate through the largest possible surface area.

You have connected all cables for the STO safety function.



### More information

In order to prevent inadvertent inhibition of the "STO" function in the FSA ... FSC converter, we recommend protecting the associated switch with a cable tie.

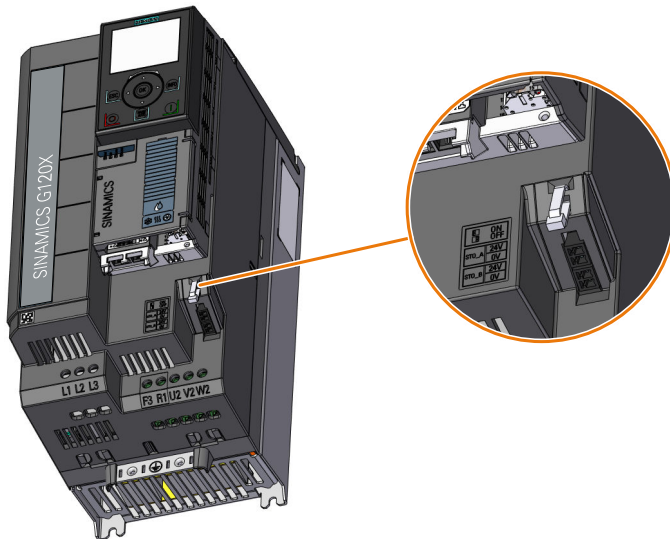

Figure 4-25 Protection against inadvertent inhibition of the "STO" function, FSA ... FSC

## 4.2.8 Application examples for "Safe Torque Off"

### Overview

A higher-level control system is required to select the STO safety function.

### Preconditions

#### Basic prerequisites

- The digital outputs for the feedback of STO are correctly parameterized.  
 Setting the feedback signal for Safe Torque Off (Page 220)
- The higher-level control system monitors the selection of the STO safety function and the feedback from the converter.
- Forced checking procedure (test stop):  
 The higher-level control system regularly selects the STO safety function and evaluates the converter feedback signal.  
 We recommend that you implement a time monitoring function in the higher-level control system, which issues an alarm if a test stop is overdue.



**Prerequisites for SIL 2/PL d**

- Suitable higher-level controllers
  - SIRIUS 3SK1: Single-channel static feedback circuit
  - SIRIUS 3SK2: Two-channel dynamic feedback circuit
  - MSS 3RK3: Two-channel dynamic feedback circuit
  - SIMATIC: Feedback circuit monitoring in the safety program
- Forced checking procedure (test stop) once per year

**Prerequisites for SIL 3/PL e**

- Suitable higher-level controllers
  - SIRIUS 3SK1: Single-channel static feedback circuit  
Permissible for converters FSH and FSJ, not permissible for FSA ... FSG
  - SIRIUS 3SK2: Two-channel dynamic feedback circuit
  - MSS 3RK3: Two-channel dynamic feedback circuit
  - SIMATIC: Feedback circuit monitoring in the safety program
- Forced checking procedure (test stop) every 3 months

**Function description****SIRIUS 3SK1 safety relay**

Figure 4-26 Connection 3SK1 inside a control cabinet for FSA ... FSG

You can achieve SIL 2/PL d with a SIRIUS 3SK1 safety relay and the converter FSA ... FSG.

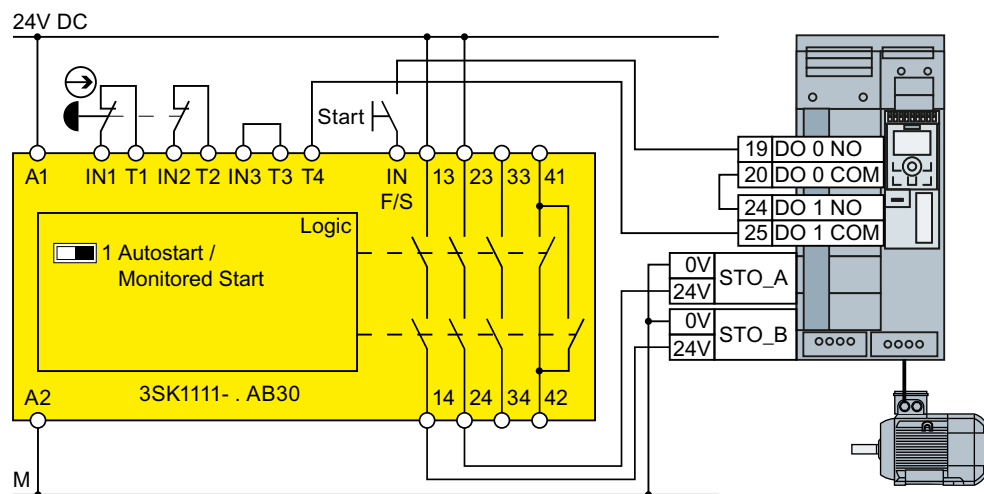
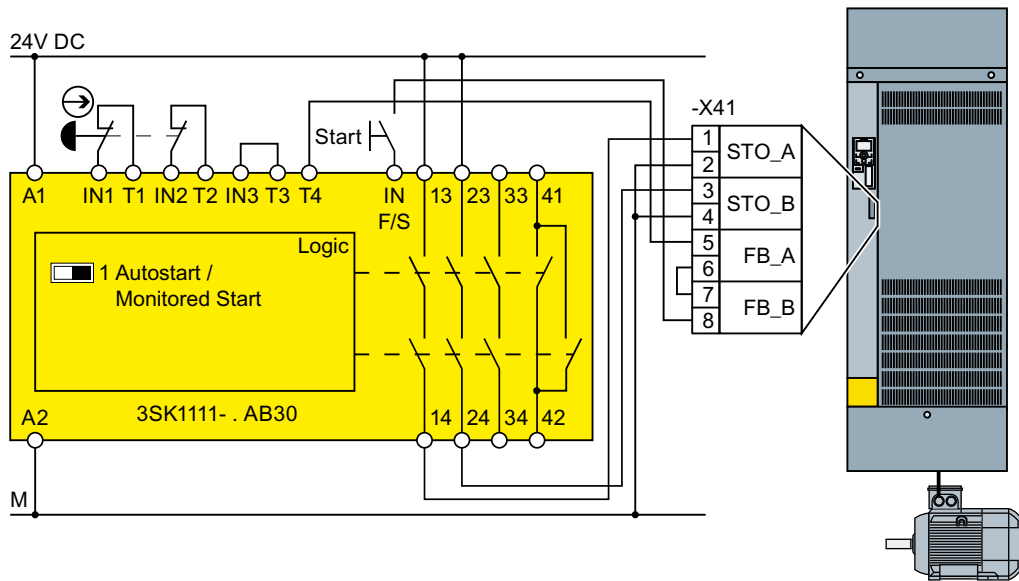

Figure 4-27 Connection 3SK1 inside a control cabinet for FSH, FSJ

You can achieve SIL 3/PL e with a SIRIUS 3SK1 safety relay and the converter FSH or FSJ.

**SIRIUS 3SK2 safety relay**

The wiring examples are implemented using safety relays with relay enable circuits. Safety relays with semiconductor enable circuits can also be used.

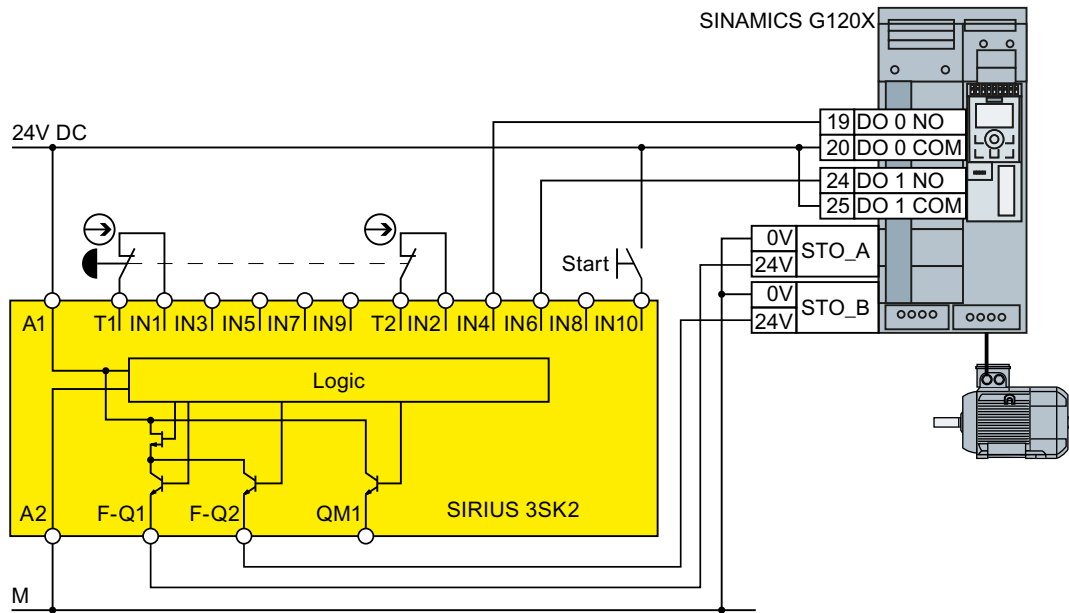
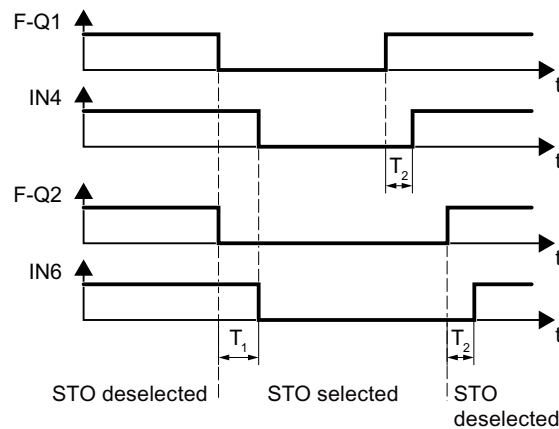

Figure 4-28 Connection 3SK2 inside a control cabinet for FSA ... FSG



$T_1 \geq 30$  ms                      In case of deviating feedback, the safety relay must select the STO function  
 $T_2 \geq 20$  ms                      and indicate an error.

Figure 4-29 Dynamic monitoring of STO feedback for FSA ... FSG

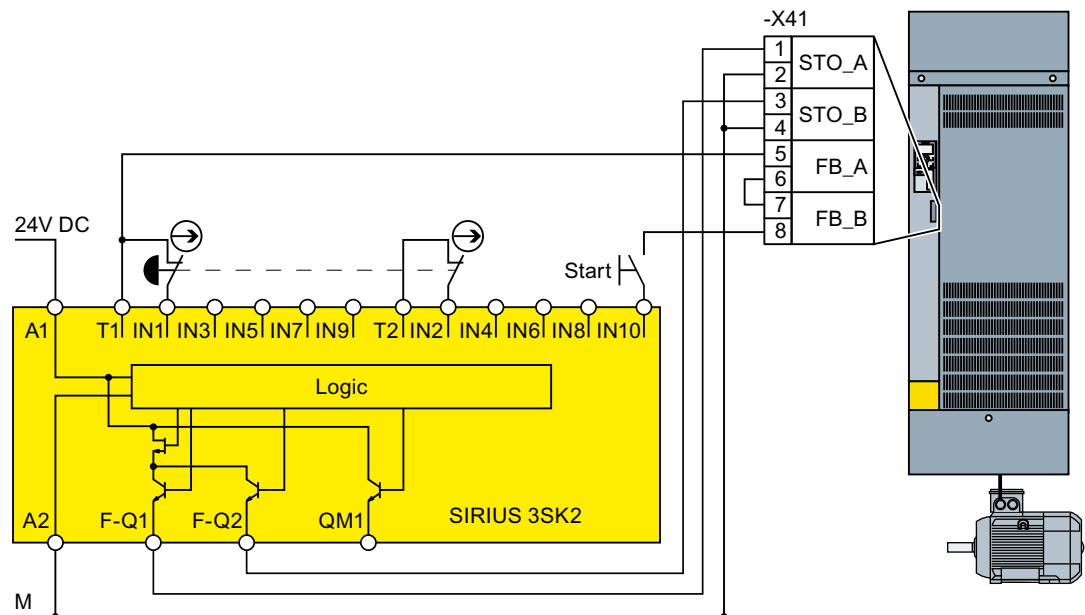

Figure 4-30 Connection 3SK2 inside a control cabinet for FSH and FSJ

Static monitoring of STO feedback at start-up is sufficient for the converters FSH and FSJ.

### Modular 3RK3 safety system

You can use the following outputs to control the failsafe digital inputs in the converter:

- The failsafe digital outputs in the central units of the 3RK3 modular safety system
- The failsafe digital outputs in the EM 2/4F-DI 2F-DO expansion module
- The failsafe digital outputs in the EM 4F-DO expansion module.
- The failsafe relay outputs in the EM 4/8F-RO expansion module
- 2 individual relay contacts of the EM 2/4F-DI 1/2F-RO expansion module

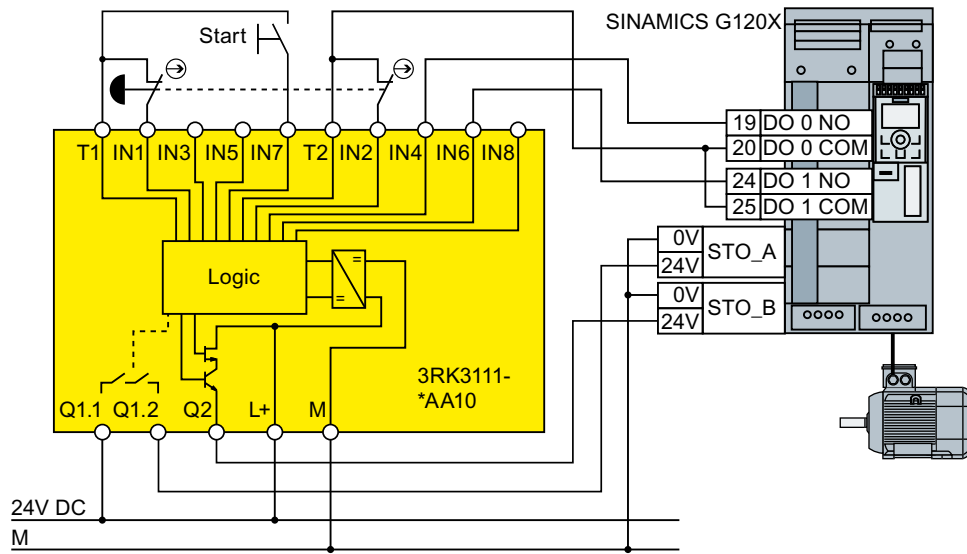
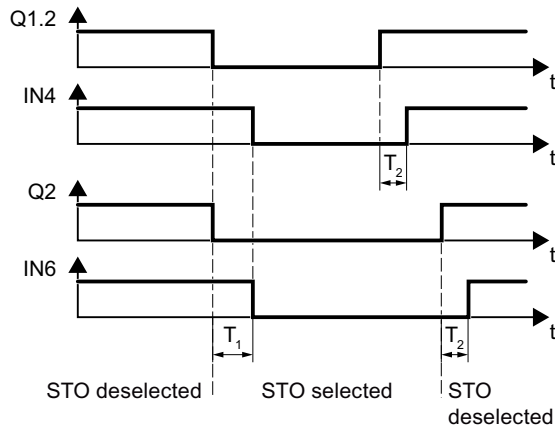

Figure 4-31 Connection 3RK3 inside a control cabinet for FSA ... FSG



$T_1 \geq 30 \text{ ms}$

$T_2 \geq 20 \text{ ms}$

In case of deviating feedback, the Modular Safety System must select the STO function and indicate an error.

Figure 4-32 Dynamic monitoring of STO feedback for FSA ... FSG

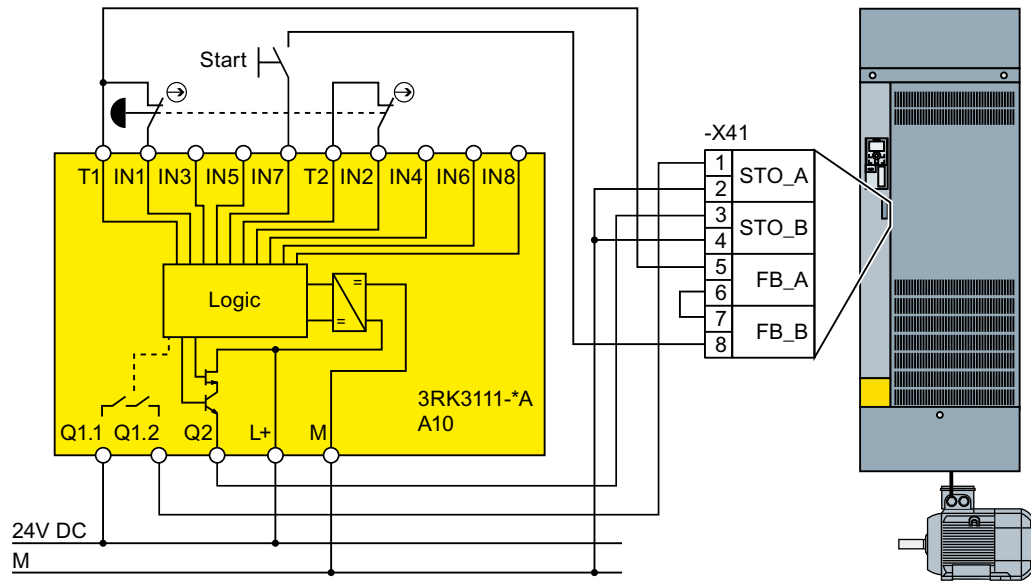

Figure 4-33 Connection 3RK3 inside a control cabinet for FSH and FSJ

Static monitoring of STO feedback at start-up is sufficient for the converters FSH and FSJ.

**SIMATIC I/O modules**

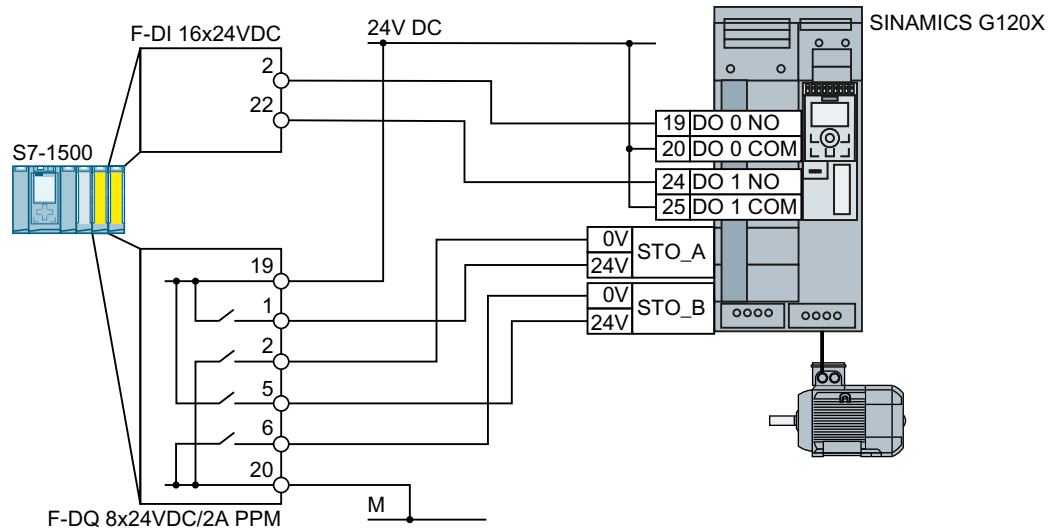
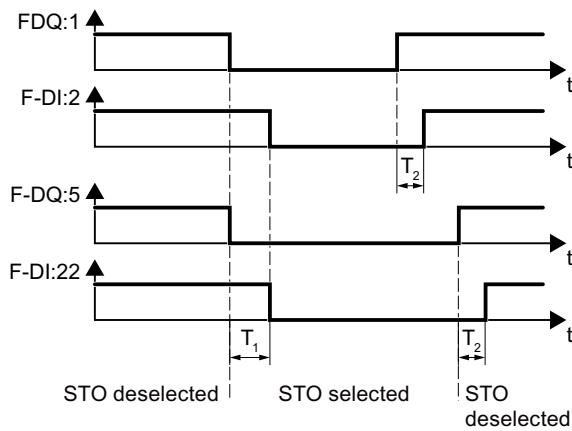

Figure 4-34 Connecting the SIMATIC S7-1500 in a control cabinet for FSA ... FSG



$T_1 \geq 30 \text{ ms}$                       In case of deviating feedback, the SIMATIC must select the STO function and indicate an error.  
 $T_2 \geq 20 \text{ ms}$

Figure 4-35 Dynamic monitoring of STO feedback for FSA ... FSG

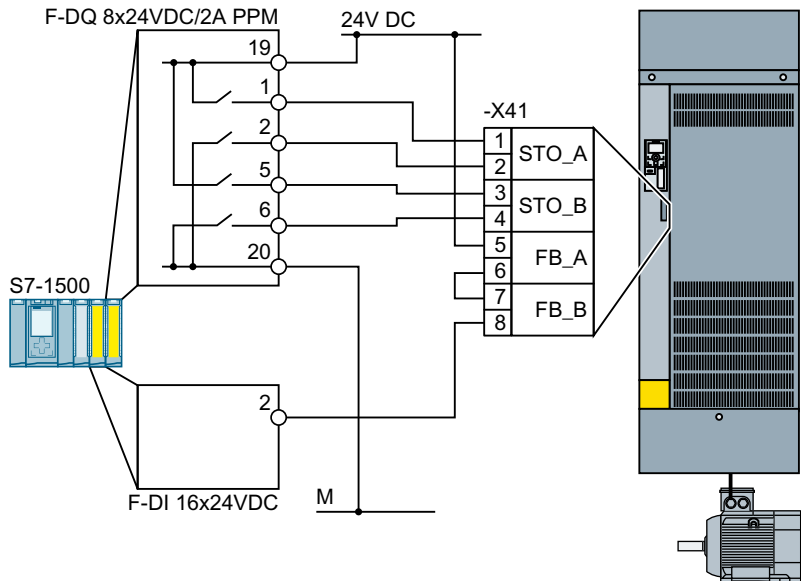

Figure 4-36 Connection of the SIMATIC S7-1500 inside a control cabinet for FSH and FSJ

Static monitoring of STO feedback for STO selection is sufficient for the converters FSH and FSJ.

### More information

Further information is provided on the Internet:

 SIRIUS 3SK1 safety relays (<https://support.industry.siemens.com/cs/ww/en/ps/16381/man>)

 SIRIUS 3SK2 Safety Relays (<https://support.industry.siemens.com/cs/ww/en/view/109444336>)

 SIRIUS 3RK3 modular safety system manual (<https://support.industry.siemens.com/cs/ww/en/view/26493228>)

-  S7-1500 (<https://support.industry.siemens.com/cs/ww/en/view/86140384>)
-  ET 200SP (<https://support.industry.siemens.com/cs/ww/en/view/84133942>)
-  ET 200pro (<https://support.industry.siemens.com/cs/ww/en/view/22098524>)
-  ET 200S (<https://support.industry.siemens.com/cs/ww/en/view/12490437>)
-  S7-300 (<https://support.industry.siemens.com/cs/ww/en/view/19026151>)

## 4.2.9 Wiring the terminal strips



### **WARNING**

#### **Electric shock due to unsuitable motor temperature evaluation system**

Voltage flashovers to the electronics of the converter can occur in motors without safe electrical separation of the temperature sensors in accordance with IEC 61800-5-1 when the motor develops a fault.

- Install a temperature monitoring relay 3RS1... or 3RS2...
- Evaluate the temperature monitoring relay output using a digital input of the converter, e.g. using the "External fault" function.

You can find additional information about the temperature monitoring relay on the Internet:

-  Manual 3RS1 / 3RS2 temperature monitoring relays (<https://support.industry.siemens.com/cs/ww/en/view/54999309>)

### **Note**

#### **Malfunction caused by incorrect switching states as the result of diagnostic flows in the off state (logical state "0")**

In contrast to mechanical switching contacts, e.g. emergency stop switches, diagnostic flows can also flow with semiconductor switches in the off state. If interconnection with digital inputs is faulty, the diagnostic flows can lead to incorrect switching states and thus to a malfunction of the drive.

- Observe the conditions for digital inputs and digital outputs specified in the relevant manufacturers documentation.
- Check the conditions of the digital inputs and digital outputs in regard to the flows in off state. If applicable, connect the digital inputs with suitably dimensioned, external resistors to protect against the reference potential of the digital inputs.



**⚠ WARNING**

**Electric shock due to damaged insulation**

Damaged insulation of cables carrying hazardous voltages can cause a short circuit with cables carrying non-hazardous voltages. This can have the effect that parts of the converter or the installation carry an unexpectedly high voltage.

- Use only cables with double insulation for 230 V cables which you connect to the digital outputs of the converter.

**NOTICE**

**Overvoltages for long signal cables**

Using > 30 m long cables at the converter's digital inputs and 24 V power supply or inductive circuits at the digital inputs can lead to overvoltage. Overvoltages can damage the converter.

- Connect an overvoltage protection device between the terminal and the associated reference potential.  
We recommend using the Weidmüller overvoltage protection terminal with designation MCZ OVP TAZ DIODE 24VDC.

Table 4-10 Permissible cable and wiring options

Solid or finely-stranded conductor	Finely stranded conductor with non-insulated end sleeve	Finely stranded conductor with partially insulated end sleeve	Two finely-stranded conductors with the same cross-section with partially insulated twin end sleeves

**Wiring the terminal strip in compliance with EMC**

- If you use shielded cables, then you must connect the shield to the mounting plate of the control cabinet or with the shield support of the converter through a good electrical connection and a large surface area.  
Further information about EMC-compliant wiring is available on the Internet:  
 EMC installation guideline (<http://support.automation.siemens.com/WW/view/en/60612658>)
- Use the shield connection plate of the Control Unit as strain relief.  
 Mounting the shield connection kits (Page 63)



## 4.2.10 Connecting to PROFINET and Ethernet

### 4.2.10.1 Communication via PROFINET IO and Ethernet

You can either integrate the converter in a PROFINET network or communicate with the converter via Ethernet.

#### The converter in PROFINET IO operation

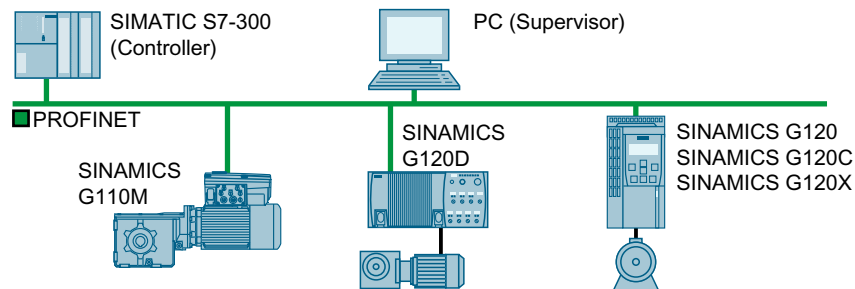

Figure 4-37 The converter in PROFINET IO operation

The converter supports the following functions:

- RT
- IRT: The converter forwards the clock synchronism, but does not support clock synchronism.
- MRP: Media redundancy, impulsed with 200 ms. Precondition: Ring topology  
With MRP, you get an uninterrupted switchover if you set the failure monitoring time to a value > 200 ms.
- MRPD: Media redundancy, bumpless. Precondition: IRT and the ring topology created in the control
- Diagnostic alarms in accordance with the error classes specified in the PROFIdrive profile.
- Device replacement without removable data storage medium: The replacement converter is assigned the device name from the IO controller, not from its memory card or from the programming device.
- Shared Device for converters that support PROFI-safe.

#### The converter as Ethernet node

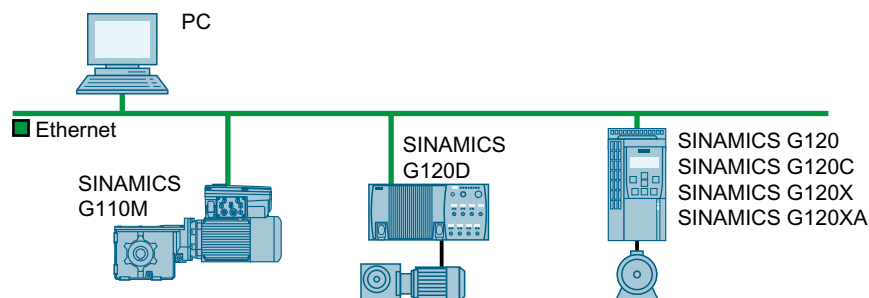



Figure 4-38 The converter as Ethernet node

### Further information on PROFINET

Further information on PROFINET can be found on the Internet:

-  PROFINET system description (<https://support.industry.siemens.com/cs/ww/en/view/19292127>)
-  PROFINET – the Ethernet standard for automation (<http://w3.siemens.com/mcms/automation/en/industrial-communications/profinet/Pages/Default.aspx>)

#### 4.2.10.2 Connecting the PROFINET cable to the converter

##### Procedure

1. Integrate the converter in the bus system (e.g. ring topology) of the control using PROFINET cables and the two PROFINET sockets X150-P1 and X150-P2.  
 Overview of the interfaces (Page 94)  
The maximum permitted cable length from the previous station and to the next one is 100 m.
2. Externally supply the converter with 24 VDC through terminals 31 and 32.  
The external 24 V supply is only required if communications with the control should also run when the line voltage is switched off.

You have connected the converter to the control system via PROFINET.



#### 4.2.10.3 What do you have to set for communication via PROFINET?

##### Configuring PROFINET communication in the I/O controller

You require the appropriate engineering system for the IO controller to configure PROFINET communication in the IO controller.

If required, load the GSDML file of the converter into the engineering software.

 Installing GSDML (Page 121)

##### Device name

In addition to the MAC address and IP address, PROFINET also uses the device name to identify PROFINET devices (Device name). The device name must be unique across the PROFINET network.

You assign the device name with the IO controller engineering software.

The converter saves the device name on the memory card plugged into the converter.

##### IP address

In addition to the device name, PROFINET also uses an IP address.

The IO Controller assigns an IP address to the converter.

## Telegram

Set the same telegram in the converter as in the IO Controller. Interconnect the telegrams in the control program of the IO Controller with the signals of your choosing.

 Drive control via PROFINET (Page 174)

## Application examples

You can find application examples for PROFINET communication on the Internet:

 Controlling the speed of a SINAMICS G110M/G120/G120C/G120D with S7-300/400F via PROFINET or PROFIBUS, with Safety Integrated (via terminal) and HMI (<https://support.industry.siemens.com/cs/ww/en/view/60441457>)

 Controlling the speed of a SINAMICS G110M / G120 (Startdrive) with S7-1500 (TO) via PROFINET or PROFIBUS, with Safety Integrated (via terminal) and HMI (<https://support.industry.siemens.com/cs/ww/en/view/78788716>)

### 4.2.10.4 Installing GSDML

#### Procedure

1. Save the GSDML to your PC.
  - With Internet access:  
 GSDML (<https://support.industry.siemens.com/cs/ww/en/view/109763250>)
  - Without Internet access:  
Insert a memory card into the converter.  
Set p0804 = 12.  
The converter writes the GSDML as a zipped file (\*.zip) into directory /SIEMENS/SINAMICS/DATA/CFG on the memory card.
2. Unzip the GSDML file on your computer.
3. Import the GSDML into the engineering system of the controller.

You have now installed the GSDML in the engineering system of the controller.







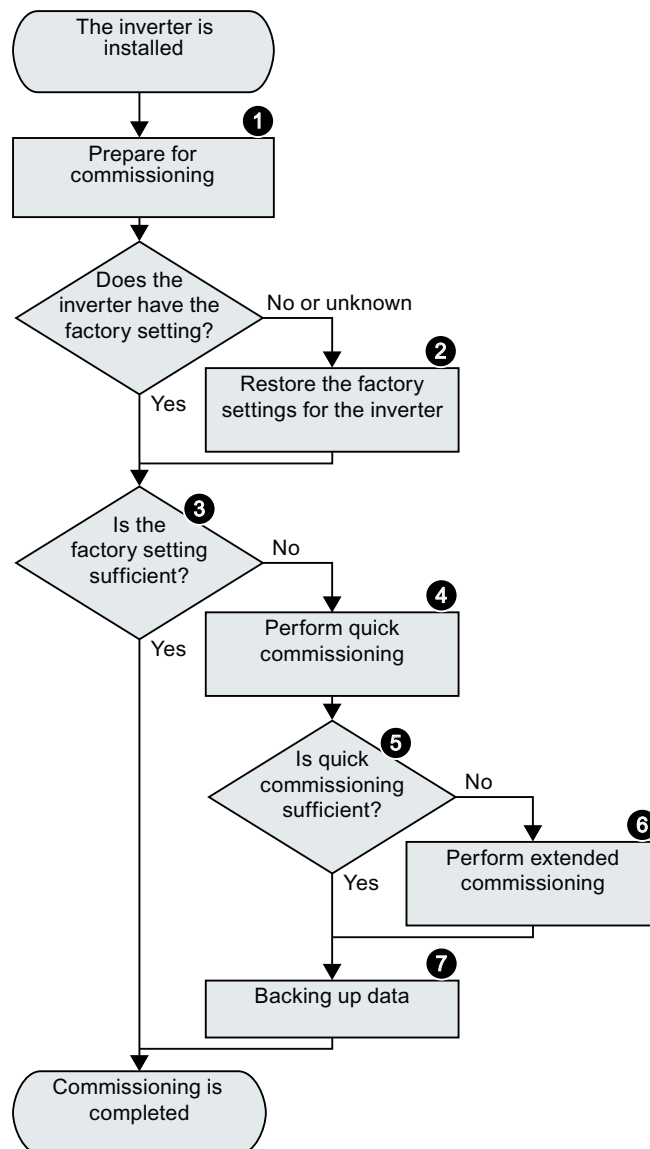

## Commissioning

### 5.1 Commissioning guidelines

#### Overview



1. Define the requirements to be met by the drive for your application.  
 (Page 125)
2. Restore the factory settings of the converter if necessary.  
 (Page 145)
3. Check if the factory setting of the converter is sufficient for your application.  
 (Page 129)
4. Set the following for quick commissioning of the drive:
  - The closed-loop motor control
  - The inputs and outputs
  - The fieldbus interface (Page 131)
5. Check if additional converter functions are required for the application.  
 (Page 125)
6. If necessary, adapt the drive.  
 (Page 147)
7. Save your settings.  
 (Page 759)

## 5.2 Tools

### Operator panel

An operator panel is used to commission, troubleshoot and control the converter, as well as to back up and transfer the converter settings.



The **Intelligent Operator Panel (IOP-2)** can either be snapped onto a converter, or is available as handheld device with a connecting cable to the converter. The graphics-capable plain text display of the IOP-2 enables intuitive converter operation.

Additional information on the IOP-2 is available in the Internet:

 SINAMICS IOP-2 release for sale (<https://support.industry.siemens.com/cs/ww/en/view/109747625>)



The **Operator Panel BOP-2** for snapping onto the converter has a two-line display for diagnostics and operating the converter.

Operating Instructions of the BOP-2 and IOP-2 operator panels:

 Manuals and technical support (Page 932)

### SINAMICS G120 Smart Access



The SINAMICS G120 Smart Access is a Web server module and an engineering tool that provides wireless connection to a PC, a tablet, or a smartphone. It is designed for quick commissioning, parameterization, and maintenance of the converters. SINAMICS G120 Smart Access is only for commissioning and thus cannot be used with the converter permanently.

Operating instructions of the SINAMICS G120 Smart Access:

 Overview of the manuals (Page 932)

### Compliance with the General Data Protection Regulation

Siemens respects the principles of data protection, in particular the data minimization rules (privacy by design).

For this product, this means:

The product does not process neither store any person-related data, only technical function data (e.g. time stamps). If the user links these data with other data (e.g. shift plans) or if he stores person-related data on the same data medium (e.g. hard disk), thus personalizing these data, he has to ensure compliance with the applicable data protection stipulations.

## 5.3 Preparing for commissioning

### 5.3.1 Collecting motor data

#### Data for a standard induction motor

Before starting commissioning, you must know the following data:

- **Which motor is connected to the converter?**  
Note down the Article No. of the motor and the motor's nameplate data. If available, note down the motor code on the motor's nameplate.

Article No.

SIEMENS		IE3		H		CE				
Made in Czech Rep.										
3-Mot.		1AV3094A		1LE10430EA422AA0-Z		UD 1410/1410842-001-001				
IEC/EN 60034		90L		IMB3		IP55				
20kg		Th.Cl.155(F)		-20°C<=TAMB<=40°C						
Bearing										
DE		6205-2ZC3								
NE		6004-2ZC3								
IEC		V	Hz	A	kW	cos φ	NOM.EFF	1/min	IE-CL	Code
IEC		230 Δ	50	7.3	2.20	0.88	85.9	2910	IE3	
IEC		400 Y	50	4.20	2.20	0.88	85.9	2910	IE3	
NEMA		460 Y	60	4.20	2.55	0.88	86.5	3510	IE3	
NEMA		460 Y	60	3.65	2.20	0.87	86.5	3530	IE3	

Voltage      Current      Power      Speed

Figure 5-1 Example of the rating plate for a standard induction motor

- **In which region of the world is the motor to be used?**
  - Europe IEC: 50 Hz [kW]
  - North America NEMA: 60 Hz [hp] or 60 Hz [kW]
- **How is the motor connected?**  
Pay attention to the connection of the motor (star connection [Y] or delta connection [Δ]). Note the appropriate motor data for connecting.

**Data for a synchronous reluctance motor**

Before starting commissioning, you must know the following data:

- **Which motor is connected to the converter?**  
Note down the motor code on the type plate of the motor.



<b>SIEMENS</b>															
Made in Germany															
3-Mot. 1RV4205B 1FP10042AB521AF4 E XXX/XXXXXXXX XX 001															
IEC/EN 60034 200L				IMB3		IP55									
167 kg		Th.Cl. 155(F)		-20°C<=TAMB<=40°C											
○		Bearing								○					
DE		6212-ZC3													
NE		6212-ZC3													
INVERTER DUTY ONLY										VPWM		SINAMICS		NMAX 4500 1/min	
V	Hz	A	kW	cos φ	Nm	1/min	EFF	Code							
380	Y 50	68	30.0	0.71	191	1500	94.9	60007							
220	Δ 50	117	30.0	0.71	191	1500	94.9								
440	Y 60	66	34.5	0.72	183	1800	95.9								
380	Δ 87	118	52.0	0.71	191	2610	94.4								

Figure 5-2 Example of a type plate for a reluctance motor

- **In which region of the world is the motor to be used?**  
- Europe IEC: 50 Hz [kW]  
- North America NEMA: 60 Hz [hp] or 60 Hz [kW]
- **How is the motor connected?**  
Pay attention to the connection of the motor (star connection [Y] or delta connection [Δ]).  
Note the appropriate motor data for connecting.



## 5.3.2 Forming DC link capacitors

### Overview

You have to reform the DC link capacitors if the converter has been stored for more than one year. Non-formed DC link capacitors can damage the converter in operation.

### Precondition

The converter has not yet been used, and according to the production date it was made over a year ago.

The production date of the converter is coded in the 3rd and 4th digit of the serial number on the rating plate: S . . ③④...

- Example: Serial number S ZVK5375000118 → Production date May 2018

Table 5-1 Production year and month

Digit ③	Production year	Digit ④	Production month
K	2018	1 ... 9	January ... September
L	2019	0	October
M	2020	N	November
...	...	D	December

### Function description

#### Procedure for FSA ... FSG

You form the DC link capacitors by supplying the converter with a line voltage of  $\leq 100\%$  of the rated voltage for a defined time.

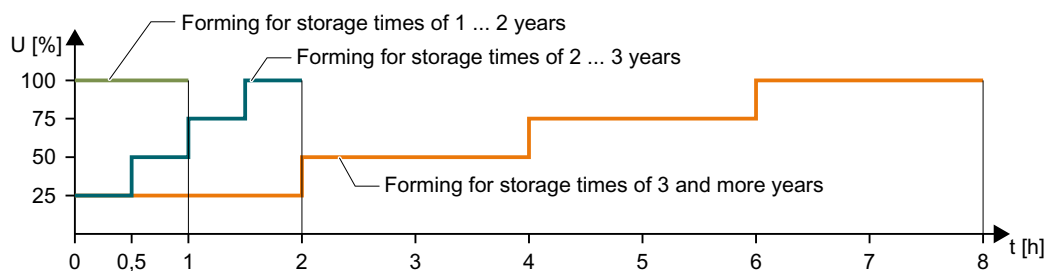

Figure 5-3 Forming the DC link capacitors

**Procedure for FSH and FSJ**

1. Set p0010 = 2.
2. Set the forming duration p3380.

Storage time from the production date	Recommended forming duration
1 ... 2 years	1 hour
2 ... 3 years	2 hours
> 3 years	8 hours

For p3380 > 0, with alarm A07391, the converter signals that at the next ON command, DC link forming starts.

3. Switch on the motor, e.g. from an inserted operator panel.
4. Wait for the forming time to elapse. r3381 indicates the remaining time.  
If the line voltage is switched off before forming has been completed, then you have to form the DC link again.
5. The converter sets p3380 = 0.
6. Set p0010 = 0.

You have formed the DC link.



**Parameter**

Parameter	Description	Factory setting
p0010	Drive commissioning parameter filter	0
p3380	Forming activation/duration	0 h
r3381	Remaining forming time	- h
r3382	Forming status word	-

### 5.3.3 Converter factory setting

#### Motor

In the factory, the converter is set for an induction motor with 2 pole pairs that matches the rated power of the converter.

#### Converter interfaces

The inputs and outputs and the fieldbus interface of the converter have specific functions when set to the factory settings.

 Factory interface settings (Page 99)

#### Switching the motor on and off

The converter is set in the factory as follows:

- After the ON command, the motor accelerates within the ramp-up time (referred to 1500 rpm) to its speed setpoint.
- After the OFF1 command, the motor brakes down to standstill with the ramp-down time.
- The negative direction of rotation is inhibited

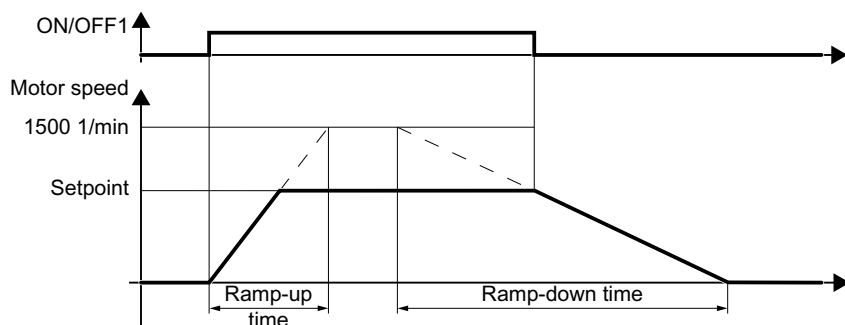

Ramp-up time 10 s

Figure 5-4 Switch motor on and off in the factory setting

The ramp-up and ramp-down times define the maximum motor acceleration when the speed setpoint changes. The ramp-up and ramp-down times are derived from the time between motor standstill and the maximum speed, or between the maximum speed and motor standstill.

#### Traverse the motor in the jog mode

For a converter with PROFINET interface, operation can be switched over using digital input DI 4. The motor is either switched on and off via the fieldbus – or operated in the jog mode via its digital inputs.

For a control command at the respective digital input, the motor rotates with  $\pm 150$  rpm. The same ramp-up and ramp-down times as described above apply.

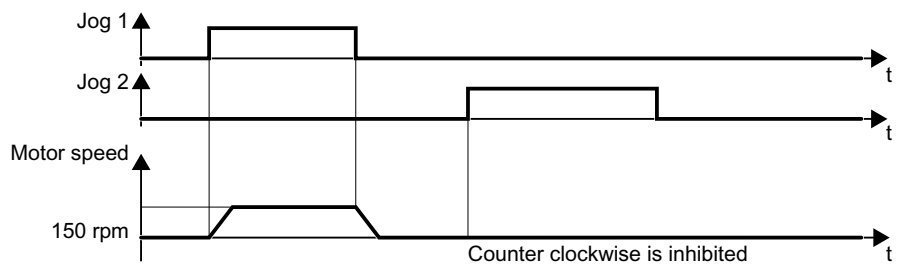

Figure 5-5 Jogging the motor in the factory setting

### Minimum and maximum speed

- Minimum speed - factory setting 0 [rpm]  
After the selection of a motor, during the quick commissioning, the converter sets the minimum speed to 20% of the rated speed.  
The minimum speed is the lowest speed of the motor independent of the speed setpoint.
- Maximum speed - factory setting 1500 [rpm]  
The converter limits the motor speed to this value.

### Operate the motor in the factory setting

We recommend that you execute quick commissioning. For quick commissioning, you must adapt the converter to the connected motor by setting the motor data in the converter.

For basic applications, you can try to operate the drive with a rated power < 18.5 kW without any other commissioning steps. Check whether the control quality of the drive without commissioning is adequate for the requirements of the application.

## 5.4 Quick commissioning using the BOP-2 operator panel

### 5.4.1 Fitting the BOP-2 to the converter

#### Fitting the BOP-2 to the converter

##### Procedure

1. Open the cover of the interface X21 on the front of the Control Unit.
2. Locate the lower edge of the Operator Panel into the matching recess of the Control Unit.
3. Plug the operator panel BOP-2 onto the converter until the latch audibly engages.

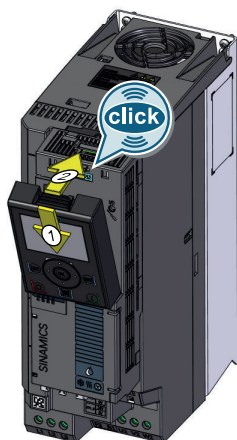

You have plugged the BOP-2 onto the converter.



The operator panel BOP-2 is ready for operation when you connect the converter to the power supply.

### 5.4.2 Overview of quick commissioning

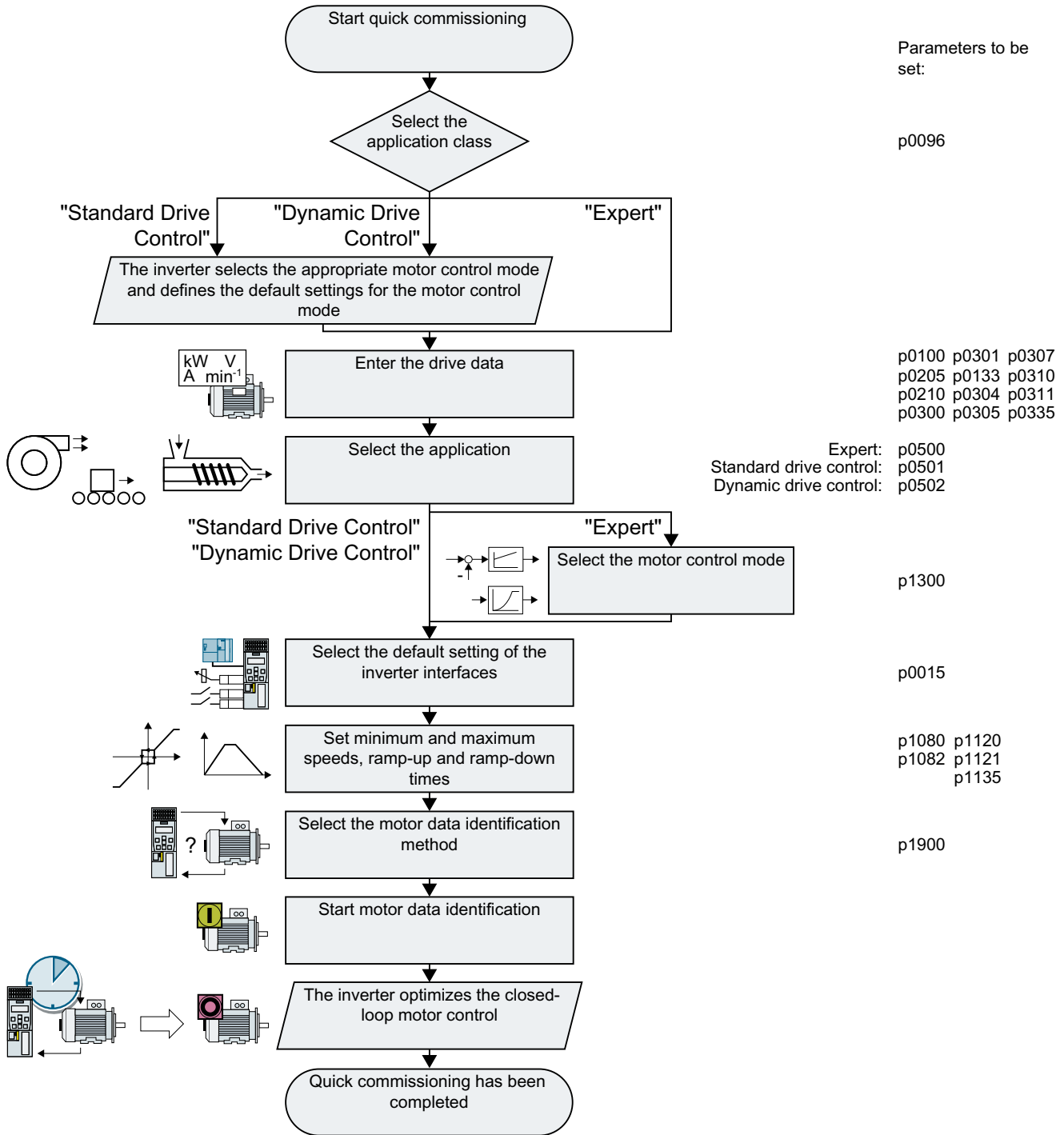

Figure 5-6 Quick commissioning using the BOP-2 operator panel

### 5.4.3 Start quick commissioning and select the application class

#### Starting quick commissioning

##### Preconditions

- The power supply is switched on.
- The operator panel displays setpoints and actual values.

##### Procedure



Press the ESC key.



Press one of the arrow keys until the BOP-2 displays the "SETUP" menu.

To start quick commissioning, in the "SETUP" menu, press the OK key.

If you wish to restore all of the parameters to the factory setting before the quick commissioning, proceed as follows:

1. Press the OK key.
2. Switchover the display using an arrow key: nO → YES
3. Press the OK key.

When selecting an application class, the converter assigns the motor control with the appropriate default settings:

- Standard Drive Control (Page 135)
- Dynamic Drive Control (Page 137)
- Expert (Page 139)

Depending on the particular Power Module, the converter skips selecting the application class. If the BOP-2 does not display step DRV APPL, then continue commissioning as described under "Expert".

### 5.4.4 Selecting an application class

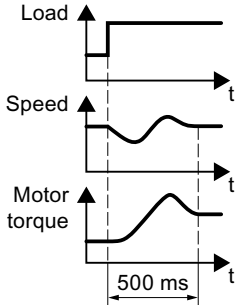
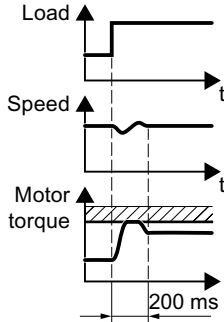
Application class	Standard Drive Control	Dynamic Drive Control
<b>Properties</b>	<ul style="list-style-type: none"> <li>• Typical settling time after a speed change: 100 ms ... 200 ms</li> <li>• Typical settling time after a load surge: 500 ms</li> </ul>  <ul style="list-style-type: none"> <li>• Standard Drive Control is suitable for the following requirements: <ul style="list-style-type: none"> <li>– Motor power ratings &lt; 45 kW</li> <li>– Ramp-up time 0 → rated speed (depending on the motor power rating): 1 s (0.1 kW) ... 10 s (45 kW)</li> <li>– Applications with steady load torque without load surges</li> </ul> </li> <li>• Standard Drive Control is insensitive with respect to imprecise setting of the motor data</li> </ul>	<ul style="list-style-type: none"> <li>• Typical settling time after a speed change: &lt; 100 ms</li> <li>• Typical settling time after a load surge: 200 ms</li> </ul>  <ul style="list-style-type: none"> <li>• Dynamic Drive Control controls and limits the motor torque</li> <li>• Torque accuracy that can be achieved: ± 5% for 15% ... 100% of the rated speed</li> <li>• We recommend Dynamic Drive Control for the following applications: <ul style="list-style-type: none"> <li>– Motor power ratings &gt; 11 kW</li> <li>– For load surges of 10% ... &gt;100% of the rated motor torque</li> </ul> </li> <li>• Dynamic Drive Control is necessary for a ramp-up time 0 → rated speed (dependent on the rated motor power): &lt; 1 s (0.1 kW) ... &lt; 10 s (132 kW).</li> </ul>
<b>Application examples</b>	<ul style="list-style-type: none"> <li>• Pumps, fans, and compressors with flow characteristic</li> </ul>	<ul style="list-style-type: none"> <li>• Pumps and compressors with displacement machines</li> </ul>
<b>Motors that can be operated</b>	Induction motors	Induction and synchronous motors
<b>Max. output frequency</b>	550 Hz	240 Hz
<b>Torque control</b>	Without torque control	Speed control with lower-level torque control
<b>Commissioning</b>	<ul style="list-style-type: none"> <li>• Unlike "Dynamic Drive Control," no speed controller needs to be set</li> <li>• Compared with the "EXPERT" setting: <ul style="list-style-type: none"> <li>– Simplified commissioning using predefined motor data</li> <li>– Reduced number of parameters</li> </ul> </li> <li>• Standard Drive Control is preset for converters of frame size A ... frame size C</li> </ul>	<ul style="list-style-type: none"> <li>• Fewer parameters compared with the "EXPERT" setting</li> <li>• Dynamic Drive Control is preset for converters of frame size D ... frame size F</li> </ul>



### 5.4.5 Standard Drive Control

EUR/USA  
P100\_\_

Select the motor standard:

- KW / 50HZ: IEC
- HP / 60HZ: NEMA, US units
- KW / 60HZ: NEMA, SI units

INV VOLT  
P210\_\_

Set the converter supply voltage.

MOT TYPE  
P300\_\_

Select the motor type. If a 5-digit motor code is stamped on the motor rating plate, select the corresponding motor type with motor code.

Motors without motor code stamped on the rating plate:

- INDUCT: Third-party induction motor
- 1L... IND: 1LE1, 1LG6, 1LA7, 1LA9 induction motors

Motors with motor code stamped on the rating plate:

- 1LE1 IND 100: 1LE1 . 9
- 1PC1 IND: 1PC1

Depending on the converter, the motor list in BOP-2 can deviate from the list shown above.

MOT CODE  
P301\_\_

If you have selected a motor type with motor code, you must now enter the motor code. The converter assigns the following motor data corresponding to the motor code.

If you do not know the motor code, then you must set the motor code = 0, and enter motor data from p0304 and higher from the rating plate.

87 HZ  
\_\_

87 Hz motor operation The BOP-2 only indicates this step if you selected IEC as the motor standard (EUR/USA, P100 = kW 50 Hz).

MOT VOLT  
P304\_\_

Rated motor voltage

MOT CURR  
P305\_\_

Rated motor current

MOT POW  
P307\_\_

Rated motor power

MOT FREQ  
P310\_\_

Rated motor frequency

MOT RPM  
P311\_\_

Rated motor speed

MOT COOL  
P335\_\_

Motor cooling:

- SELF: Natural cooling
- FORCED: Forced-air cooling

5.4 Quick commissioning using the BOP-2 operator panel

TEC APPL  
P501

- LIQUID: Liquid cooling
  - NO FAN: Without fan
- Select the basic setting for the motor control:

MAc PAr  
P15

- VEC STD: Constant load
  - PUMP FAN: Speed-dependent load
- Select the default setting for the interfaces of the converter that is suitable for your application.

 Factory interface settings (Page 99)

MIN RPM  
P1080

MAX RPM  
P1082

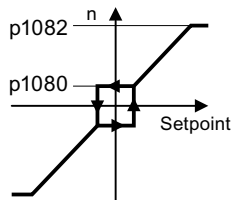

Figure 5-7 Minimum and maximum motor speed

RAMP UP  
P1120

RAMP DWN  
P1121

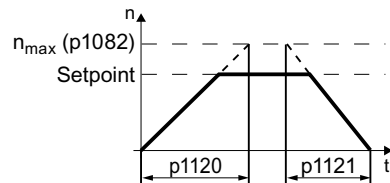

Figure 5-8 Ramp-up and ramp-down time of the motor

OFF3 RP  
P1135

Ramp-down time after the OFF3 command

MOT ID  
P1900

Motor data identification Select the method which the converter uses to measure the data of the connected motor:

- OFF: No motor data identification
- STIL ROT: Measure the motor data at standstill and with the motor rotating. The converter switches off the motor after the motor data identification has been completed.
- STILL: Recommended setting: Measure the motor data at standstill. The converter switches off the motor after the motor data identification has been completed. Select this setting if the motor cannot rotate freely.
- ROT: Measure the motor data while the motor is rotating. The converter switches off the motor after the motor data identification has been completed.
- ST RT OP: setting same as STIL ROT. After the motor data identification, the motor accelerates to the current setpoint.
- STILL OP: setting same as STILL. After the motor data identification, the motor accelerates to the current setpoint.

FINISH  
—

Complete quick commissioning as follows:

1. Switchover the display using an arrow key: nO → YES
2. Press the OK key.

You have completed quick commissioning.



## 5.4.6 Dynamic Drive Control

EUR/USA  
P100\_\_

Select the motor standard:

- KW / 50HZ: IEC
- HP / 60HZ: NEMA, US units
- KW / 60HZ: NEMA, SI units

INV VOLT  
P210\_\_

Set the converter supply voltage.

MOT TYPE  
P300\_\_

Select the motor type. If a 5-digit motor code is stamped on the motor rating plate, select the corresponding motor type with motor code.

Motors without motor code stamped on the rating plate:

- INDUCT: Third-party induction motor
- 1L... IND: 1LE1, 1LG6, 1LA7, 1LA9 induction motors

Motors with motor code stamped on the rating plate:

- 1LE1 IND 100: 1LE1 . 9
- 1PC1 IND: 1PC1

Depending on the converter, the motor list in BOP-2 can deviate from the list shown above.

MOT CODE  
P301\_\_

If you have selected a motor type with motor code, you must now enter the motor code. The converter assigns the following motor data corresponding to the motor code.

If you do not know the motor code, then you must set the motor code = 0, and enter motor data from p0304 and higher from the rating plate.

87 HZ  
\_\_

87 Hz motor operation The BOP-2 only indicates this step if you selected IEC as the motor standard (EUR/USA, P100 = kW 50 Hz).

MOT VOLT  
P304\_\_

Rated motor voltage

MOT CURR  
P305\_\_

Rated motor current

MOT POW  
P307\_\_

Rated motor power

MOT FREQ  
P310\_\_

Rated motor frequency

MOT RPM  
P311\_\_

Rated motor speed

5.4 Quick commissioning using the BOP-2 operator panel

MOT COOL  
P335

Motor cooling:

- SELF: Natural cooling
- FORCED: Forced-air cooling
- LIQUID: Liquid cooling
- NO FAN: Without fan

TEC APPL  
P502

Select the basic setting for the motor control:

- OP LOOP: Recommended setting for standard applications
- CL LOOP: Recommended setting for applications with short ramp-up and ramp-down times.
- HVY LOAD: Recommended setting for applications with a high break loose torque.

MAc PAr  
P15

Select the default setting for the interfaces of the converter that is suitable for your application.

 Factory interface settings (Page 99)

MIN RPM  
P1080

MAX RPM  
P1082

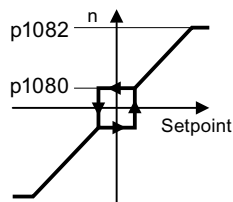

Figure 5-9 Minimum and maximum motor speed

RAMP UP  
P1120

RAMP DWN  
P1121

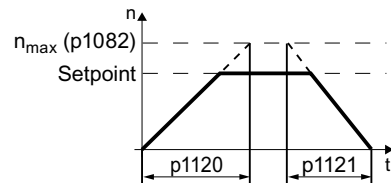

Figure 5-10 Ramp-up and ramp-down time of the motor

OFF3 RP  
P1135

Ramp-down time after the OFF3 command

MOT ID  
P1900

Motor data identification: Select the method which the converter uses to measure the data of the connected motor:

- OFF: Motor data is not measured.
- STIL ROT: Recommended setting: Measure the motor data at standstill and with the motor rotating. The converter switches off the motor after the motor data identification has been completed.
- STILL: Default setting: Measure the motor data at standstill. The converter switches off the motor after the motor data identification has been completed. Select this setting if the motor cannot rotate freely.
- ROT: Measure the motor data while the motor is rotating. The converter switches off the motor after the motor data identification has been completed.

- ST RT OP: setting same as STIL ROT.  
After the motor data identification, the motor accelerates to the current setpoint.
- STILL OP: setting same as STILL.  
After the motor data identification, the motor accelerates to the current setpoint.

FINISH

Complete quick commissioning:

- Switch over the display using an arrow key: nO → YES
- Press the OK key.

You have completed quick commissioning.



### 5.4.7 Expert

EUR/USA  
P100\_\_

Select the motor standard:

- KW / 50HZ: IEC
- HP / 60HZ: NEMA, US units
- KW / 60HZ: NEMA, SI units

LOAD TYP  
P210\_\_

Specify the overload capability of the converter:

- HIGH OVL: Duty cycle with "High Overload"
- LOW OVL: Duty cycle with "Low Overload"



Load cycles and overload capability (Page 898)

INV VOLT  
P210\_\_

Set the converter supply voltage.

MOT TYPE  
P300\_\_

Select the motor type. If a 5-digit motor code is stamped on the motor rating plate, select the corresponding motor type with motor code.

Motors without motor code stamped on the rating plate:

- INDUCT: Third-party induction motor
- 1L... IND: 1LE1, 1LG6, 1LA7, 1LA9 induction motors

Motors with motor code stamped on the rating plate:

- 1LE1 IND 100: 1LE1 . 9
- 1PC1 IND: 1PC1

Depending on the converter, the motor list in BOP-2 can deviate from the list shown above.

MOT CODE  
P301\_\_

If you have selected a motor type with motor code, you must now enter the motor code. The converter assigns the following motor data corresponding to the motor code.

If you do not know the motor code, then you must set the motor code = 0, and enter motor data from p0304 and higher from the rating plate.

87 HZ

87 Hz motor operation The BOP-2 only indicates this step if you selected IEC as the motor standard (EUR/USA, P100 = kW 50 Hz).

5.4 Quick commissioning using the BOP-2 operator panel

MOT VOLT  
P304\_\_

Rated motor voltage

MOT CURR  
P305\_\_

Rated motor current

MOT POW  
P307\_\_

Rated motor power

MOT FREQ  
P310\_\_

Rated motor frequency

MOT RPM  
P311\_\_

Rated motor speed

MOT COOL  
P335\_\_

Motor cooling:

- SELF: Natural cooling
- FORCED: Forced-air cooling
- LIQUID: Liquid cooling
- NO FAN: Without fan

TEC APPL  
P500\_\_

Select the appropriate application:

- VEC STD: In all applications, which do not fit the other setting options.
- PUMP FAN: Applications involving pumps and fans
- SLVC 0HZ: Applications with short ramp-up and ramp-down times.
- PUMP 0HZ: Applications involving pumps and fans with optimized efficiency. The setting only makes sense for steady-state operation with slow speed changes. We recommend setting VEC STD if load surges in operation cannot be ruled out.
- V LOAD: Applications with high breakaway torque

CTRL MOD  
P1300\_\_

Select the control mode:

- VF LIN: U/f control with linear characteristic
- VF LIN F: Flux current control (FCC)
- VF QUAD: U/f control with square-law characteristic
- SPD N EN: Sensorless vector control

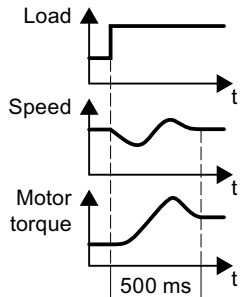
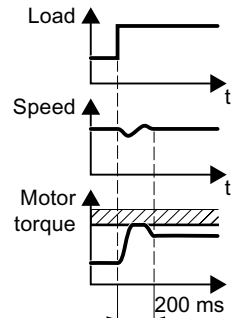
Control mode	U/f control or flux current control (FCC)	Sensorless vector control
<b>Properties</b>	<ul style="list-style-type: none"> <li>Typical settling time after a speed change: 100 ms ... 200 ms</li> <li>Typical settling time after a load surge: 500 ms</li> </ul>  <ul style="list-style-type: none"> <li>The control mode is suitable to address the following requirements: <ul style="list-style-type: none"> <li>Motor power ratings &lt; 45 kW</li> <li>Ramp-up time 0 → rated speed (depending on the motor power rating): 1 s (0.1 kW) ... 10 s (45 kW)</li> <li>Applications with steady load torque without load surges</li> </ul> </li> <li>The control mode is insensitive with respect to imprecise setting of the motor data</li> </ul>	<ul style="list-style-type: none"> <li>Typical settling time after a speed change: &lt; 100 ms</li> <li>Typical settling time after a load surge: 200 ms</li> </ul>  <ul style="list-style-type: none"> <li>The control mode controls and limits the motor torque</li> <li>Torque accuracy that can be achieved: ± 5% for 15% ... 100% of the rated speed</li> <li>We recommend the control mode for the following applications: <ul style="list-style-type: none"> <li>Motor power ratings &gt; 11 kW</li> <li>For load surges of 10% ... &gt;100% of the rated motor torque</li> </ul> </li> <li>The control mode is necessary for a ramp-up time 0 → Rated speed (dependent on the rated motor power): &lt; 1 s (0.1 kW) ... &lt; 10 s (250 kW).</li> </ul>
<b>Application examples</b>	<ul style="list-style-type: none"> <li>Pumps, fans, and compressors with flow characteristic</li> </ul>	<ul style="list-style-type: none"> <li>Pumps and compressors with displacement machines</li> </ul>
<b>Motors that can be operated</b>	Induction motors	Induction and synchronous motors
<b>Max. output frequency</b>	550 Hz	240 Hz
<b>Torque control</b>	Without torque control	Torque control with and without higher-level speed control
<b>Commissioning</b>	<ul style="list-style-type: none"> <li>In contrast to sensorless vector control, the speed controller does not have to be set</li> </ul>	

MAc PAr  
P15

Select the default setting for the interfaces of the converter that is suitable for your application.

 Factory interface settings (Page 99)

MIN RPM  
P1080

MAX RPM  
P1082

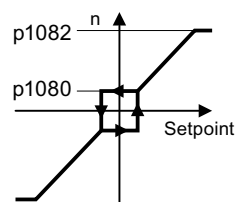

Figure 5-11 Minimum and maximum motor speed

5.4 Quick commissioning using the BOP-2 operator panel

RAMP UP  
P1120

RAMP DWN  
P1121

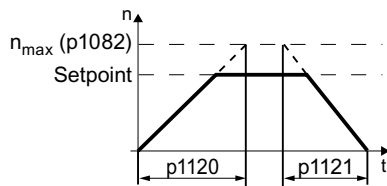

Figure 5-12 Ramp-up and ramp-down time of the motor

OFF3 RP  
P1135

Ramp-down time for the OFF3 command

MOT ID  
P1900

Motor data identification: Select the method which the converter uses to measure the data of the connected motor:

- OFF: Motor data is not measured.
- STIL ROT: Recommended setting: Measure the motor data at standstill and with the motor rotating. The converter switches off the motor after the motor data identification has been completed.
- STILL: Measure the motor data at standstill. The converter switches off the motor after the motor data identification has been completed.  
Select this setting if one of the following cases is applicable:
  - You have selected control mode "SPD N EN", but the motor cannot rotate freely.
  - You have selected U/f control as control mode, e.g. "VF LIN" or "VF QUAD".
- ROT: Measure the motor data while the motor is rotating. The converter switches off the motor after the motor data identification has been completed.
- ST RT OP: setting same as STIL ROT.  
After the motor data identification, the motor accelerates to the current setpoint.
- STILL OP: setting same as STILL.  
After the motor data identification, the motor accelerates to the current setpoint.

FINISH

Complete quick commissioning:

Switchover the display using an arrow key: nO → YES

Press the OK key.

You have completed quick commissioning.

□



## 5.4.8 Identifying the motor data and optimizing the closed-loop control

### Overview

Using the motor data identification, the converter measures the data of the stationary motor. In addition, based on the response of the rotating motor, the converter can determine a suitable setting for the vector control.

To start the motor data identification routine, you must switch-on the motor via the terminal strip, fieldbus or from the operator panel.

### Identifying the motor data and optimizing the closed-loop control

#### Requirements

- You have selected a method of motor data identification during quick commissioning, e.g. measuring motor data while the motor is stationary.  
When quick commissioning is complete, the converter issues alarm A07991.
- The motor has cooled down to the ambient temperature.  
An excessively high motor temperature falsifies the motor data identification results.



#### **WARNING**

##### **Unexpected machine motion while the motor data identification is in progress**

For the stationary measurement, the motor can make several rotations. The rotating measurement accelerates the motor up to the rated speed. Secure dangerous machine parts before starting motor data identification:

- Before switching on, ensure that nobody is working on the machine or located within its working area.
- Secure the machine's work area against unintended access.
- Lower suspended loads to the floor.

#### Procedure



Press the HAND/AUTO key.



The BOP-2 displays the symbol indicating manual operation.



Switch on the motor.



During motor data identification, "MOT-ID" flashes on the BOP-2.



If the converter again outputs alarm A07991, then it waits for a new ON command to start the rotating measurement.

5.4 Quick commissioning using the BOP-2 operator panel

If the converter does not output alarm A07991, switch off the motor as described below, and switch over the converter control from HAND to AUTO.



Switch on the motor to start the rotating measurement.



During motor data identification, "MOT-ID" flashes on the BOP-2.

The motor data identification can take up to 2 minutes depending on the rated motor power.



Depending on the setting, after motor data identification has been completed, the converter switches off the motor - or it accelerates it to the setpoint.

If required, switch off the motor.



Switch the converter control from HAND to AUTO.

You have completed the motor data identification.



Quick commissioning has been completed once the motor data identification has been successfully completed.

## 5.5 Restoring the factory settings

### Why restore the factory settings?

Reset the converter to the factory settings in the following cases:

- You do not know the converter settings.
- The line voltage was interrupted during commissioning and you were not able to complete commissioning.

### Resetting to factory setting with the BOP-2 operator panel

#### Procedure

1. In the "Options" menu, select the "DRVRESET" entry
2. Confirm the reset using the OK key.
3. Wait until the converter has been reset to the factory setting.

You have reset the converter to the factory settings.

□



## Advanced commissioning

### 6.1 Overview of the converter functions

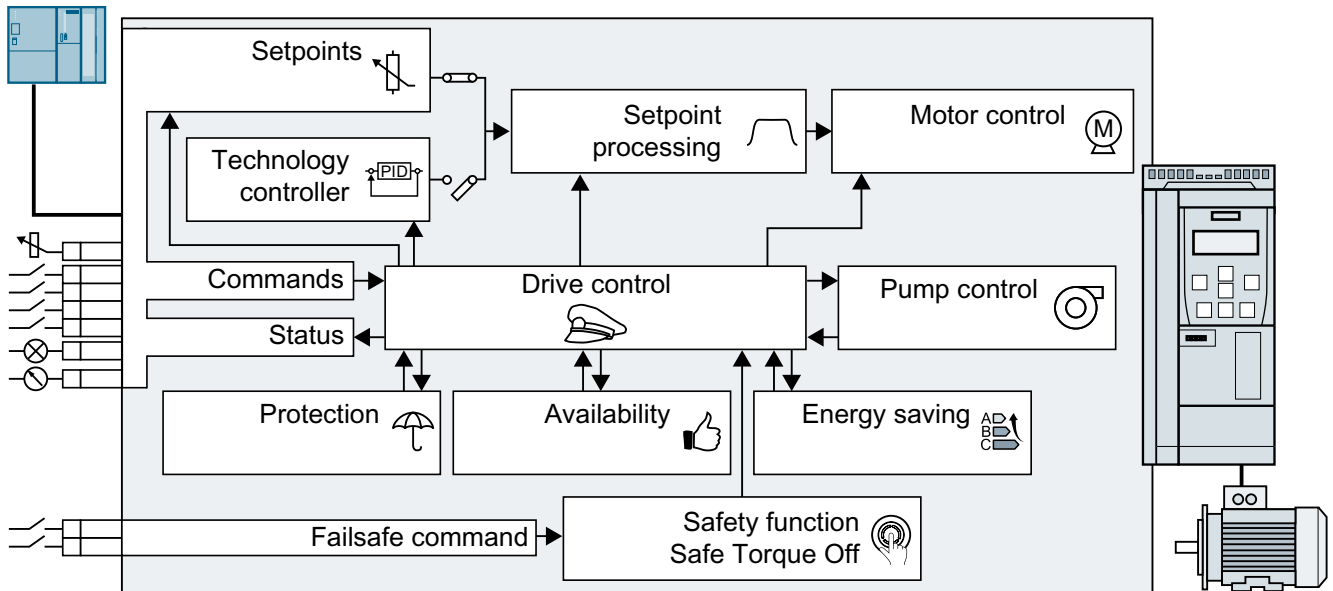

#### Drive control



The converter receives its commands from the higher-level control via the terminal strip or the fieldbus interface of the Control Unit. The drive control defines how the converter responds to the commands.

 Drive control (Page 149)

The converter can switch between different settings of the drive control.

 Switching over the drive control (command data set) (Page 214)

#### Safety functions



The safety functions fulfill increased requirements regarding the functional safety of the drive.

 Safe Torque Off (STO) safety function (Page 218)

#### Setpoints and setpoint conditioning



The setpoint generally determines the motor speed.

 Setpoints (Page 246)



The setpoint processing uses a ramp-function generator to prevent speed steps occurring and to limit the speed to a permissible maximum value.

 Setpoint processing (Page 257)

### Technology controller



The technology controller controls process variables, e.g. pressure, temperature, level or flow. The motor closed-loop control either receives its setpoint from the higher-level control - or from the technology controller.

 Technology controller (Page 269)

### Motor control



The motor closed-loop control ensures that the motor follows the speed setpoint. You can choose between various control modes.

 Motor control (Page 295)

### Drive protection



The protection functions prevent damage to the motor, converter and driven load.

 Drive protection (Page 323)

### Increasing the drive availability



The drive can bridge temporary power failures or be switched on while the motor is rotating.

 Drive availability (Page 340)

### Saving energy



The converter enhances the efficiency optimization of the standard induction motor or disconnects the power module from the system, if necessary.

 Energy saving (Page 351)

## 6.2 Drive control

### 6.2.1 Sequence control when switching the motor on and off

#### Overview



The sequence control defines the rules for switching the motor on and off.

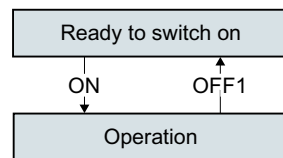

Figure 6-1 Simplified representation of the sequence control

After switching the supply voltage on, the converter normally goes into the "ready to start" state. In this state, the converter waits for the command to switch on the motor.

The converter switches on the motor with the ON command. The converter changes to the "Operation" state.

After the OFF1 command, the converter brakes the motor down to standstill. The converter switches off the motor once standstill has been reached. The converter is again "ready to start".

#### Precondition

##### Functions

In order to be able to respond to external commands, you must set the command interface so that it fits your specific application.

##### Tools

One of the commissioning tools is needed to change the function settings.

Function description

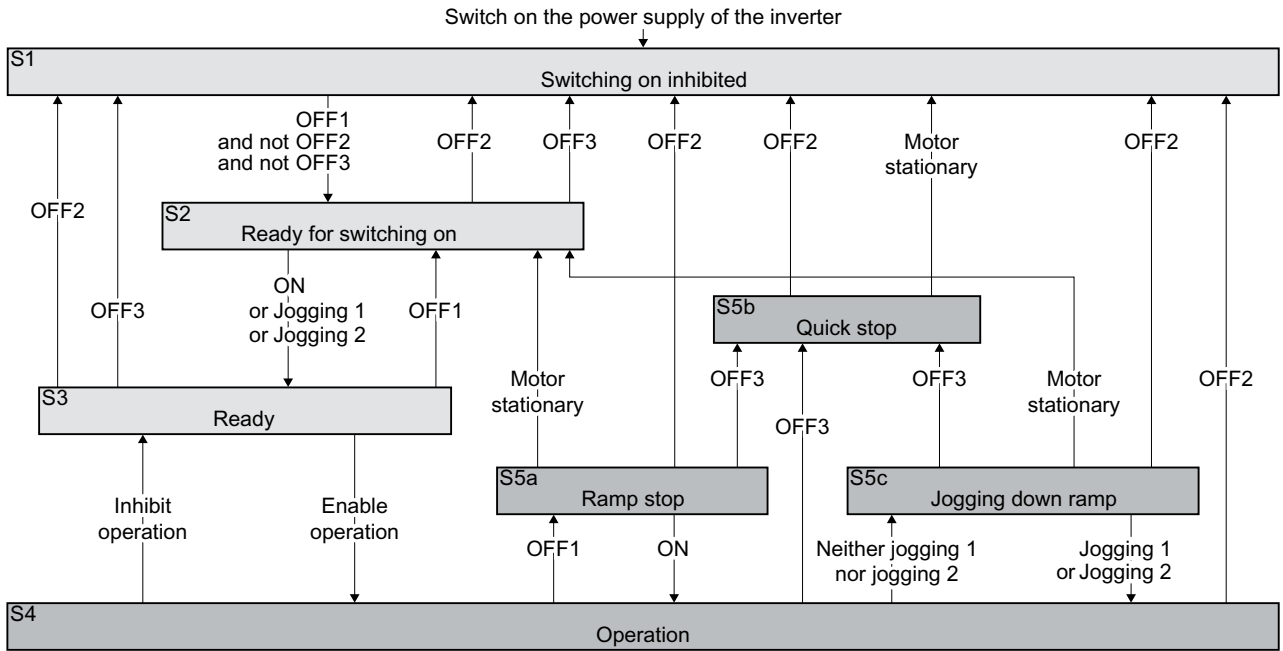

Figure 6-2 Sequence control of the converter when the motor is switched on and off

Converter states S1 ... S5c are defined in the PROFIdrive profile. The sequence control defines the transition from one state to another.

Table 6-1 Converter states

The motor is switched off		The motor is switched on	
Current does not flow in the motor and the motor does not generate any torque		Current flows in the motor and the motor generates a torque	
S1	The ON command and an OFF command are active at the same time. In order for the converter to exit the state, you must deactivate OFF2 and OFF3 and activate the ON command again.	S4	The motor is switched on.
S2	The converter waits for a new command to switch on the motor.	S5a, S5c	The motor is still switched on. The converter brakes the motor with the ramp-down time of the ramp-function generator.
S3	The converter waits for "Enable operation". The "Enable operation" command is always active in the converter factory setting.	S5b	The motor is still switched on. The converter brakes the motor with the OFF3 ramp-down time.



Table 6-2 Commands for switching the motor on and off

ON Jogging 1 Jogging 2 Enable operation	The converter switches the motor on.
OFF1, OFF3	<ol style="list-style-type: none"><li>1. The converter brakes the motor.</li><li>2. The converter switches off the motor once it comes to a standstill.</li></ol> The converter identifies that the motor is at a standstill when at least one of the following conditions is satisfied: <ul style="list-style-type: none"><li>• The speed actual value falls below the threshold in p1226, and the time started in p1228 has expired.</li><li>• The speed setpoint falls below the threshold in p1226, and the time subsequently started in p1227 has expired.</li></ul>
OFF2 Inhibit operation	The converter switches off the motor immediately without first braking it.

Function diagram

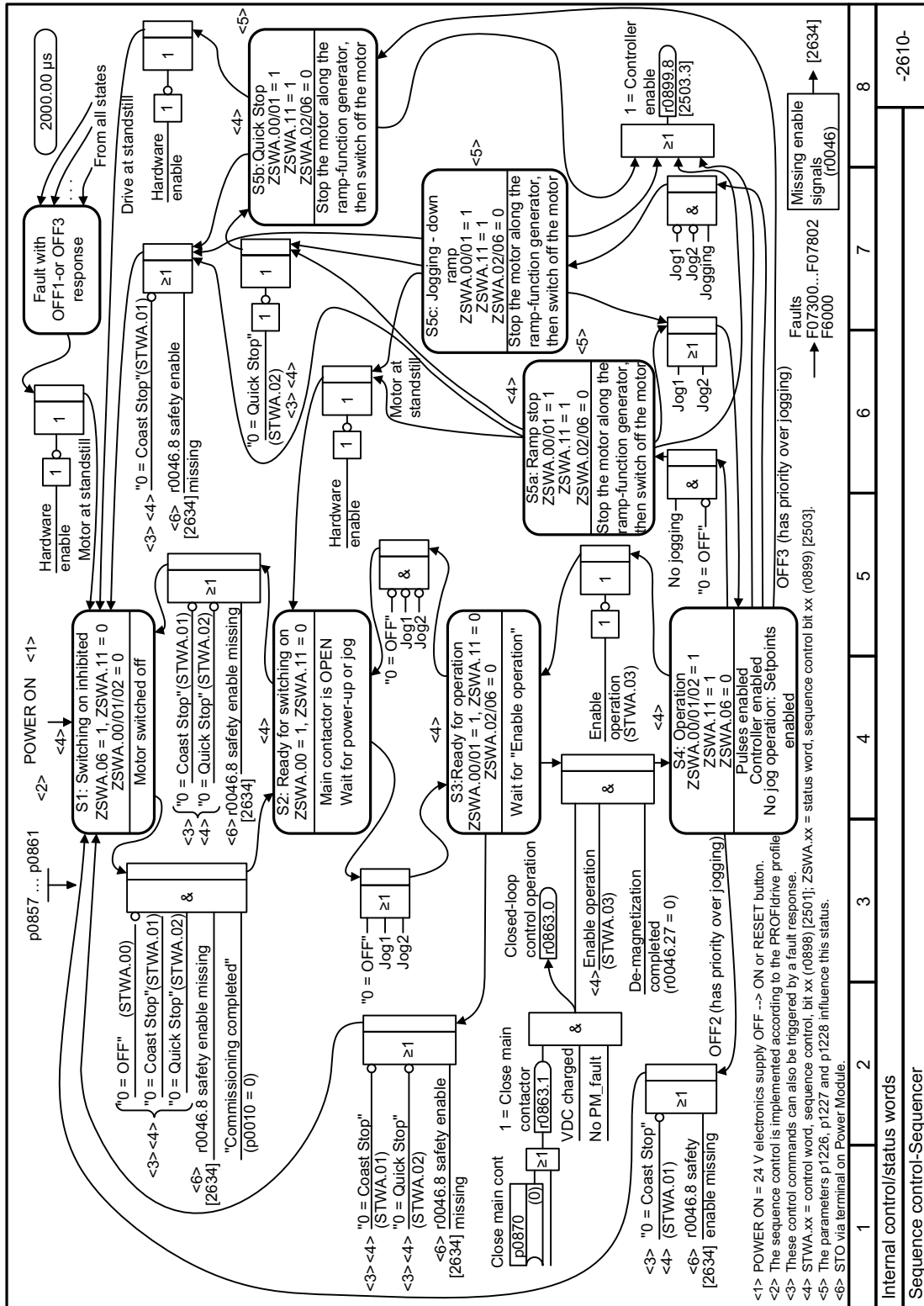

Figure 6-3 FP 2610

## Parameter

Number	Name	Factory setting
r0046.0...31	CO/BO: Missing enable signals	-
p0857	Power unit monitoring time	10000 ms
p0858[C]	BI: Unconditionally close holding brake	0
p0860	BI: Line contactor feedback signal	863.1
p0861	Line contactor monitoring time	100 ms
p1226[D]	Speed threshold for standstill detection	20 rpm
p1227	Standstill detection monitoring time	300 s
p1228	Pulse suppression delay time	0.01 s

For additional information on parameters, please refer to the parameter list.

## See also

Parameters (Page 373)

## 6.2.2 Adapt the default setting of the terminal strips

### Overview



In the converter, the input and output signals are interconnected with specific converter functions using special parameters. The following parameters are available to interconnect signals:

- Binectors BI and BO are parameters to interconnect binary signals.
- Connectors CI and CO are parameters to interconnect analog signals.

The following chapters describe how you adapt the function of individual converter inputs and outputs using binectors and connectors.

6.2 Drive control

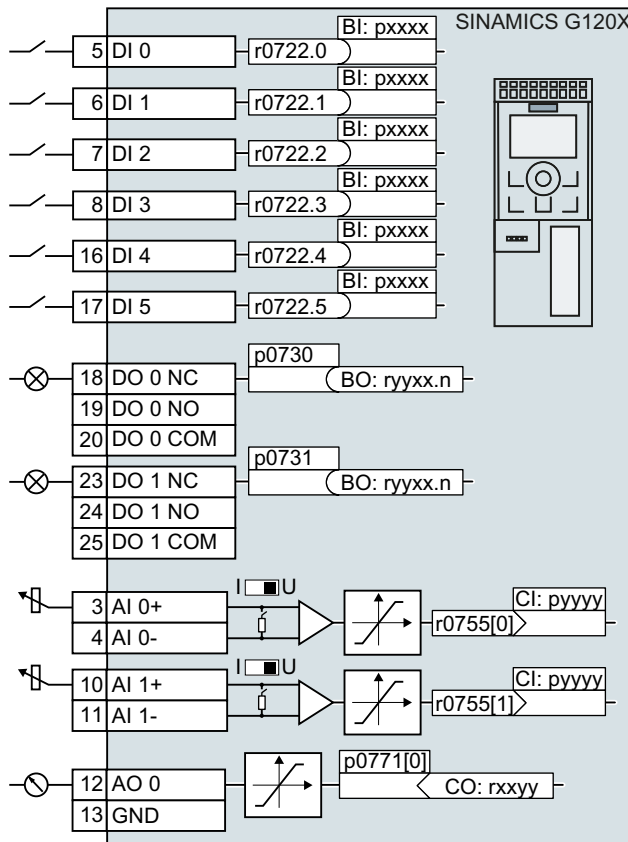

### 6.2.2.1 Digital inputs

#### Function description

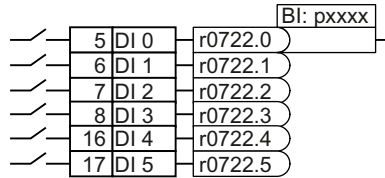

To change the function of a digital input, you must interconnect the status parameter of the digital input with a binector input of your choice.

Binector inputs are designated in the parameter list with the prefix "BI".

#### Example

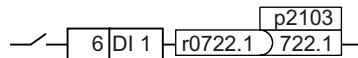

To acknowledge converter fault messages using digital input DI 1, you must interconnect DI 1 with the command to acknowledge faults (p2103).

Set p2103 = 722.1.

#### Parameters

Parameter	Description	Factory setting
r0721	CU digital inputs, terminal actual value	-
r0722	CO/BO: CU digital inputs, status	-
r0723	CO/BO: CU digital inputs, status inverted	--
p0724	CU digital inputs debounce time	4 ms
p0810	BI: Command data set selection CDS bit 0	0
p0840[C]	BI: ON/OFF (OFF1)	Dependent on the converter
p0844[C]	BI: No coast down/coast down (OFF2) signal source 1	Dependent on the converter
p0848[C]	BI: No quick stop/quick stop (OFF3) signal source 1	1
p0852[C]	BI: Enable operation/inhibit operation	Dependent on the converter
p1020[C]	BI: Fixed speed setpoint selection, bit 0	0
p1021[C]	BI: Fixed speed setpoint selection, bit 1	0
p1022[C]	BI: Fixed speed setpoint selection, bit 2	0
p1023[C]	BI: Fixed speed setpoint selection, bit 3	0
p1035[C]	BI: Motorized potentiometer setpoint higher	Dependent on the converter
p1036[C]	BI: Motorized potentiometer setpoint lower	Dependent on the converter
p1055[C]	BI: Jogging bit 0	Dependent on the converter
p1056[C]	BI: Jogging bit 1	Dependent on the converter

Parameter	Description	Factory setting
p1113[C]	BI: Setpoint inversion	Dependent on the converter
p2103[C]	BI: 1. Acknowledge faults	Dependent on the converter
p2106[C]	BI: External fault 1	1
p2112[C]	BI: External alarm 1	1

For further binector inputs and additional information on parameters, please refer to the parameter list.

 [Parameter list \(Page 376\)](#)

Function diagram

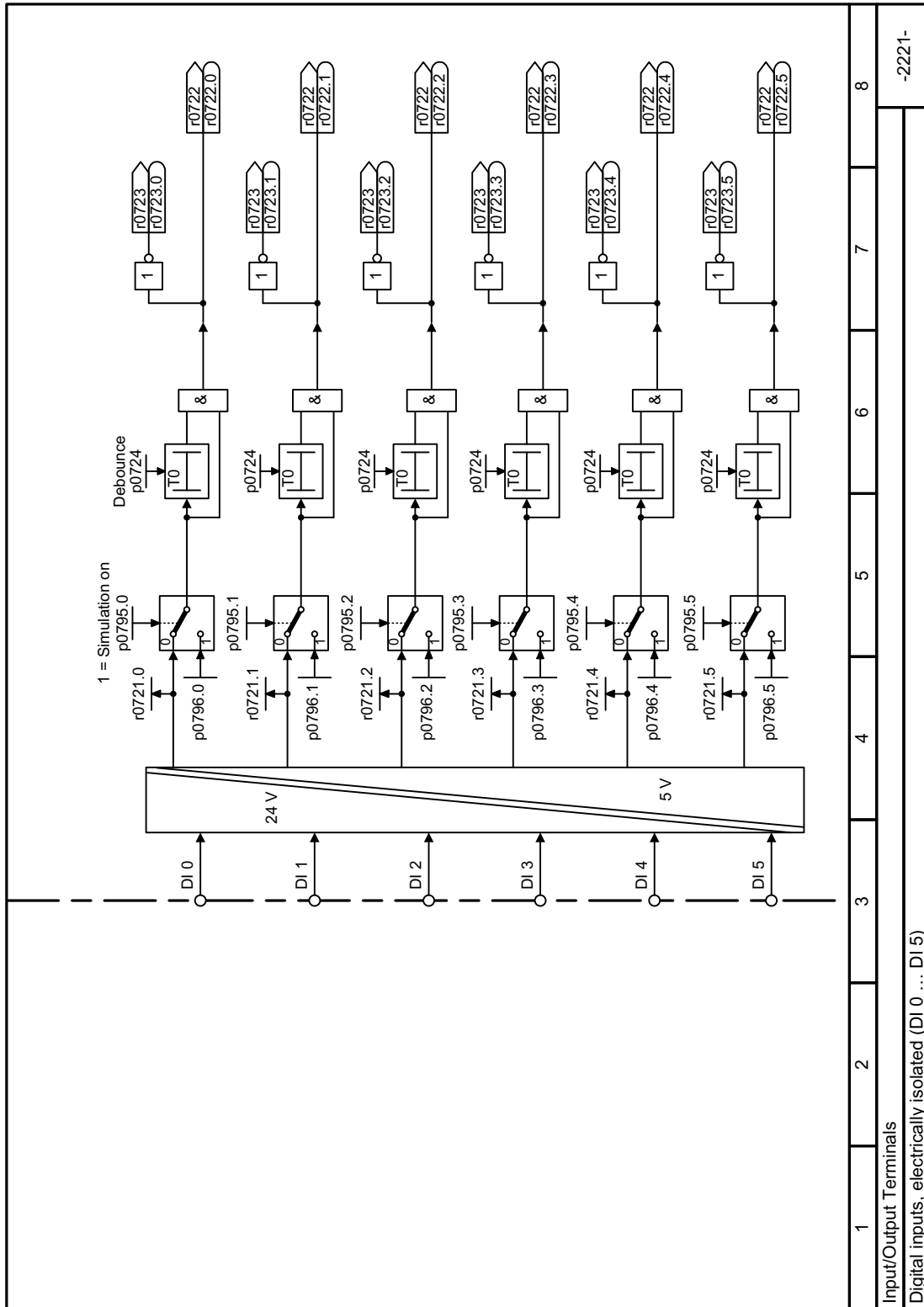
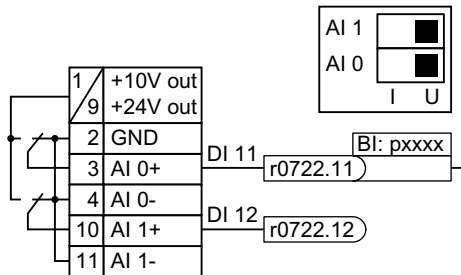

Figure 6-4 FP 2221

### 6.2.2.2 Analog input as digital input

#### Function description



To use an analog input as additional digital input, you must interconnect the corresponding status parameter r0722.11 or r0722.12 with a binector input of your choice.

You may operate the analog input as a digital input with 10 V or with 24 V.

#### NOTICE

##### Defective analog input due to overcurrent

If the analog input switch is set to "Current input" (I), a 10 V or 24 V voltage source results in an overcurrent at the analog input. An overcurrent condition destroys the analog input.

- If you use an analog input as a digital input, then you must set the analog input switch to "Voltage" (U).



Function diagram

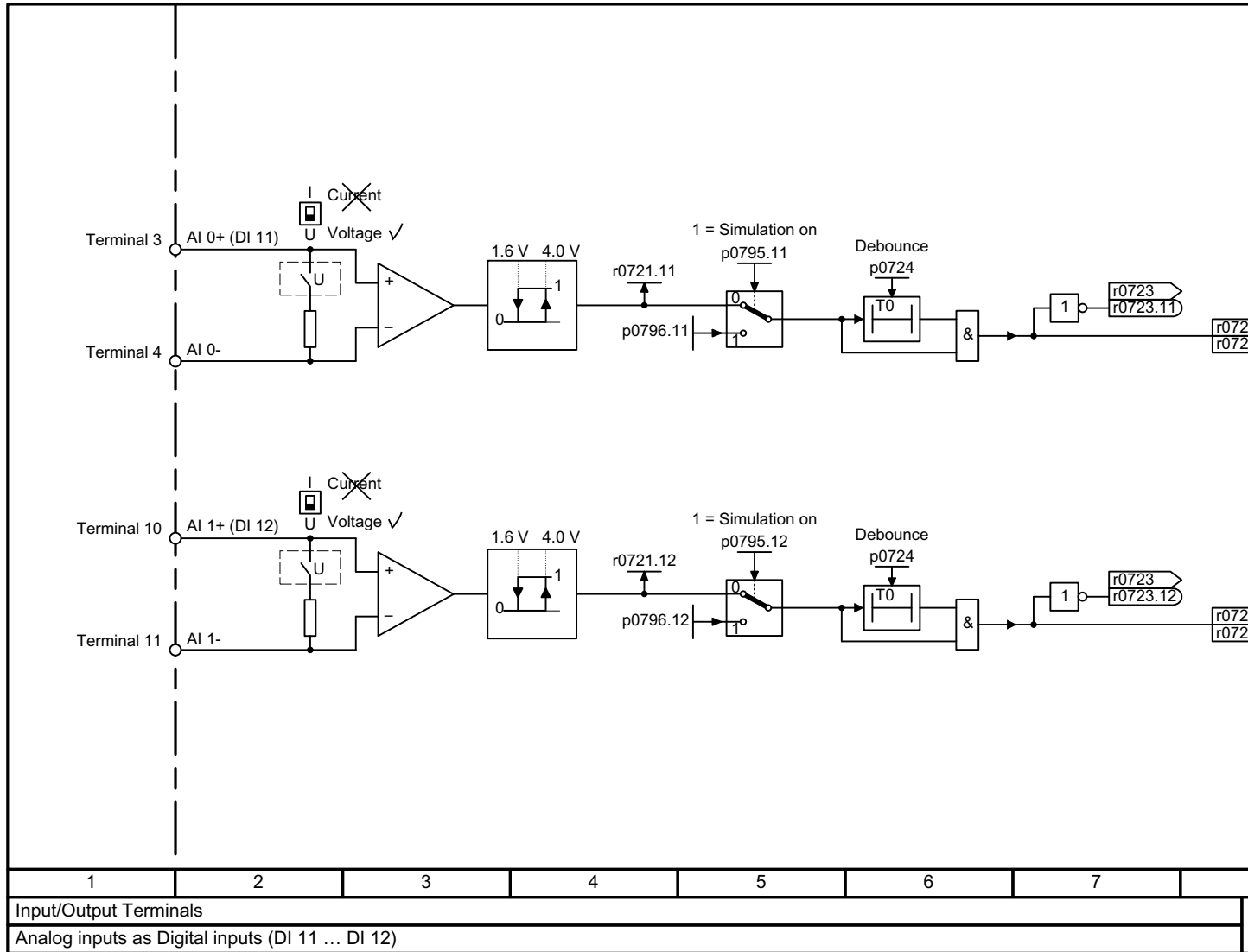
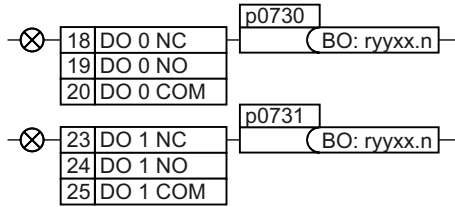

Figure 6-5 FP 2256

### 6.2.2.3 Digital outputs

#### Function description



To change the function of a digital output, you must interconnect the digital output with a binector output of your choice.

Binector outputs are designated in the parameter list with the prefix "BO".

#### Example

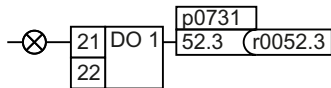

To output converter fault messages via digital output DO 1, you must interconnect DO 1 with these fault messages.

Set p0731 = 52.3

## Parameters

Table 6-3 Frequently used binector outputs (BO) of the converter

Parameter	Description	Factory setting	
r0052[0...15]	CO/BO: Status word 1	-	
	.00		1 signal: Ready for switching on
	.01		1 signal: Ready for operation
	.02		1 signal: Operation enabled
	.03		1 signal: Fault active: The converter inverts signal r0052.03 if it is interconnected to a digital output.
	.04		0 signal: OFF2 active
	.05		0 signal: OFF3 active
	.06		1 signal: Switching on inhibited active
	.07		1 signal: Alarm active
	.08		0 signal: Deviation, setpoint/actual speed
	.09		1 signal: Control request
	.10		1 signal: Maximum speed (p1082) reached
	.11		0 signal: I, M, P limit reached
	.13		0 signal: Alarm, motor overtemperature
	.14		1 signal: Motor clockwise rotation
.15	0 signal: Alarm, converter overload		
r0053[0...11]	CO/BO: Status word 2	-	
	.00		1 signal: DC braking active
	.02		1 signal: Speed > minimum speed (p1080)
	.06		1 signal: Speed ≥ setpoint speed (r1119)

You can find additional binector outputs in the parameter list.

 [Parameter list \(Page 376\)](#)

Function diagrams

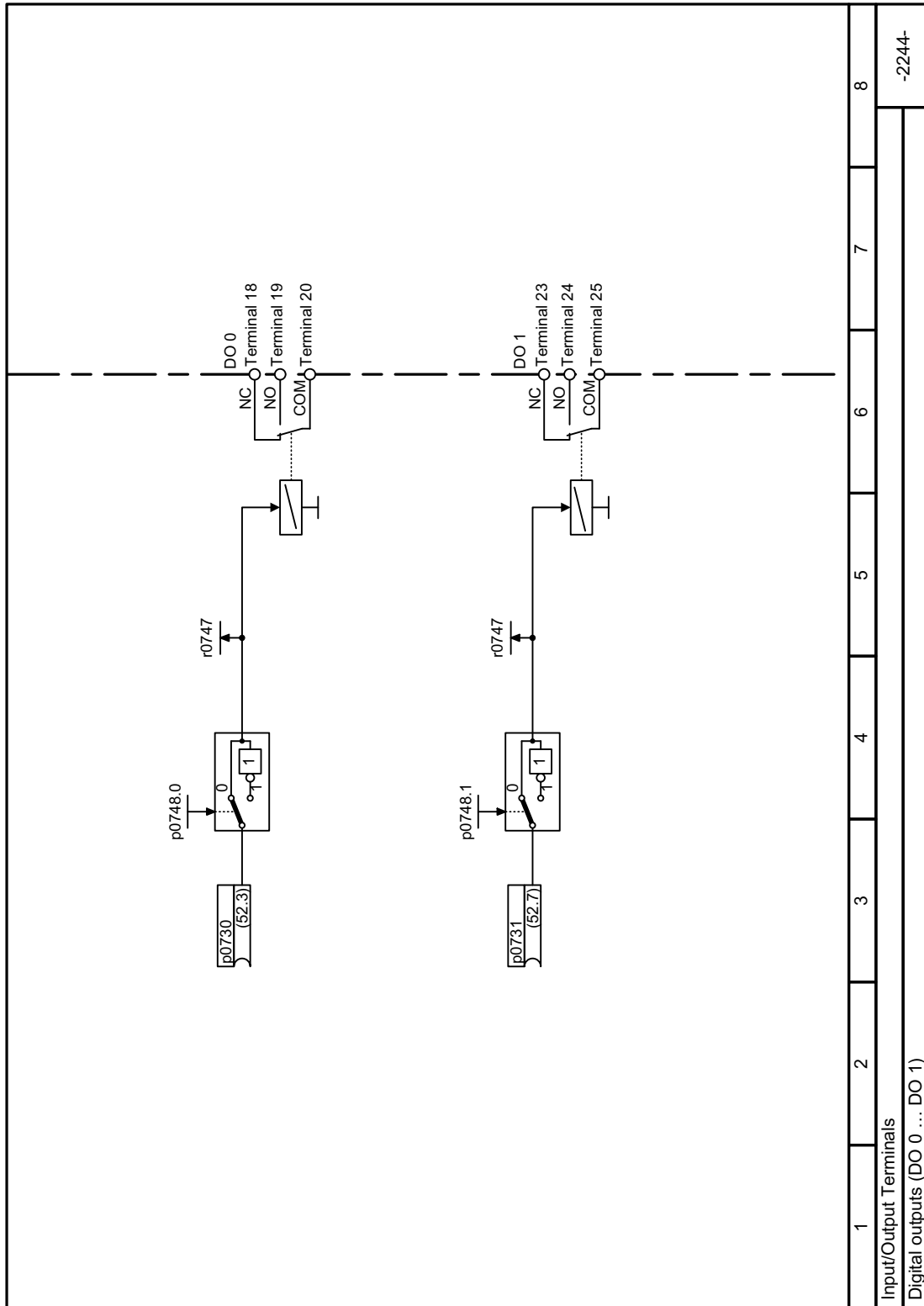

Figure 6-6 FP 2244

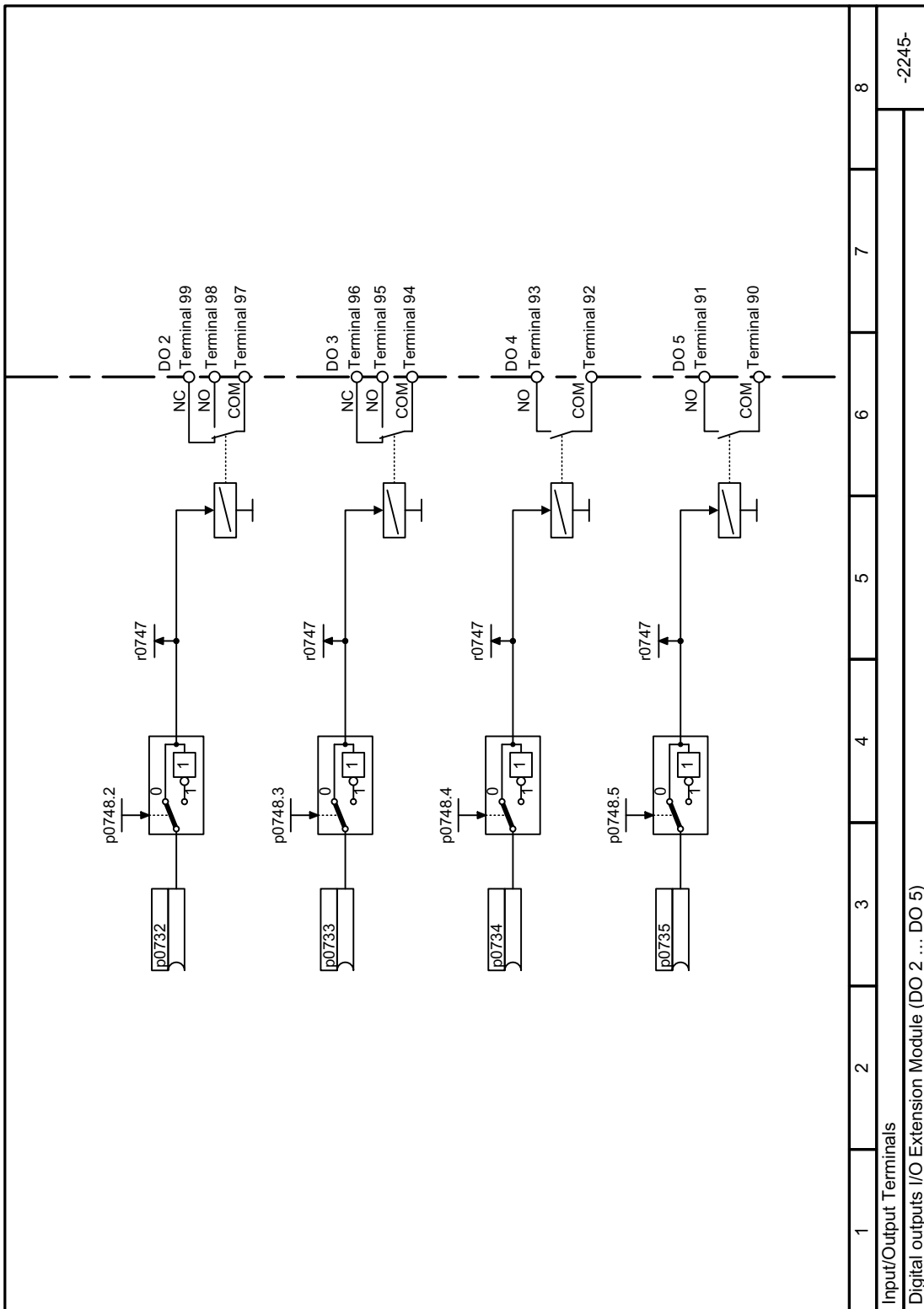

Figure 6-7 FP 2245

**See also**

Interconnecting signals in the converter (Page 930)

## 6.2.2.4 Analog inputs

### Function description

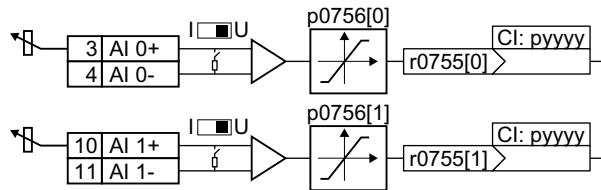

#### Define the analog input type

The parameter p0756[x] and the switch on the converter specify the analog input type.

Table 6-4 Default settings via parameter p0756

AI 0	Unipolar voltage input	0 V ... +10 V	p0756[0] =	0
	Unipolar voltage input monitored	+2 V ... +10 V		1
	Unipolar current input	0 mA ... +20 mA		2
	Unipolar current input monitored	+4 mA ... +20 mA		3
	Bipolar voltage input (factory setting)	-10 V ... +10 V		4
AI 1	Unipolar voltage input	0 V ... +10 V	p0756[1] =	0
	Unipolar voltage input monitored	+2 V ... +10 V		1
	Unipolar current input	0 mA ... +20 mA		2
	Unipolar current input monitored	+4 mA ... +20 mA		3
	Bipolar voltage input (factory setting)	-10 V ... +10 V		4

The switch that belongs to the analog input is located behind the front door of the converter.

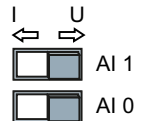

#### Defining the function of an analog input

You define the analog input function by interconnecting a connector input of your choice with parameter p0755. Parameter p0755 is assigned to the particular analog input via its index, e.g. parameter p0755[0] is assigned to analog input 0.

Connector inputs are designated in the parameter list with the prefix "CI".

### Example

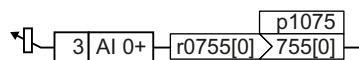

In order to enter the supplementary setpoint via analog input AI 0, you must interconnect AI 0 with the signal source for the supplementary setpoint.

Set p1075 = 755[0].

## Parameters

Table 6-5 Frequently used connector inputs (CI) of the converter

Parameter	Description	Factory setting
p1070[C]	CI: Main setpoint	Dependent on the converter
p1075[C]	CI: Supplementary setpoint	0
p2253[C]	CI: Technology controller setpoint 1	0
p2264[C]	CI: Technology controller actual value	0

You can find additional connector inputs in the parameter list.

 [Parameter list \(Page 376\)](#)



Function diagram

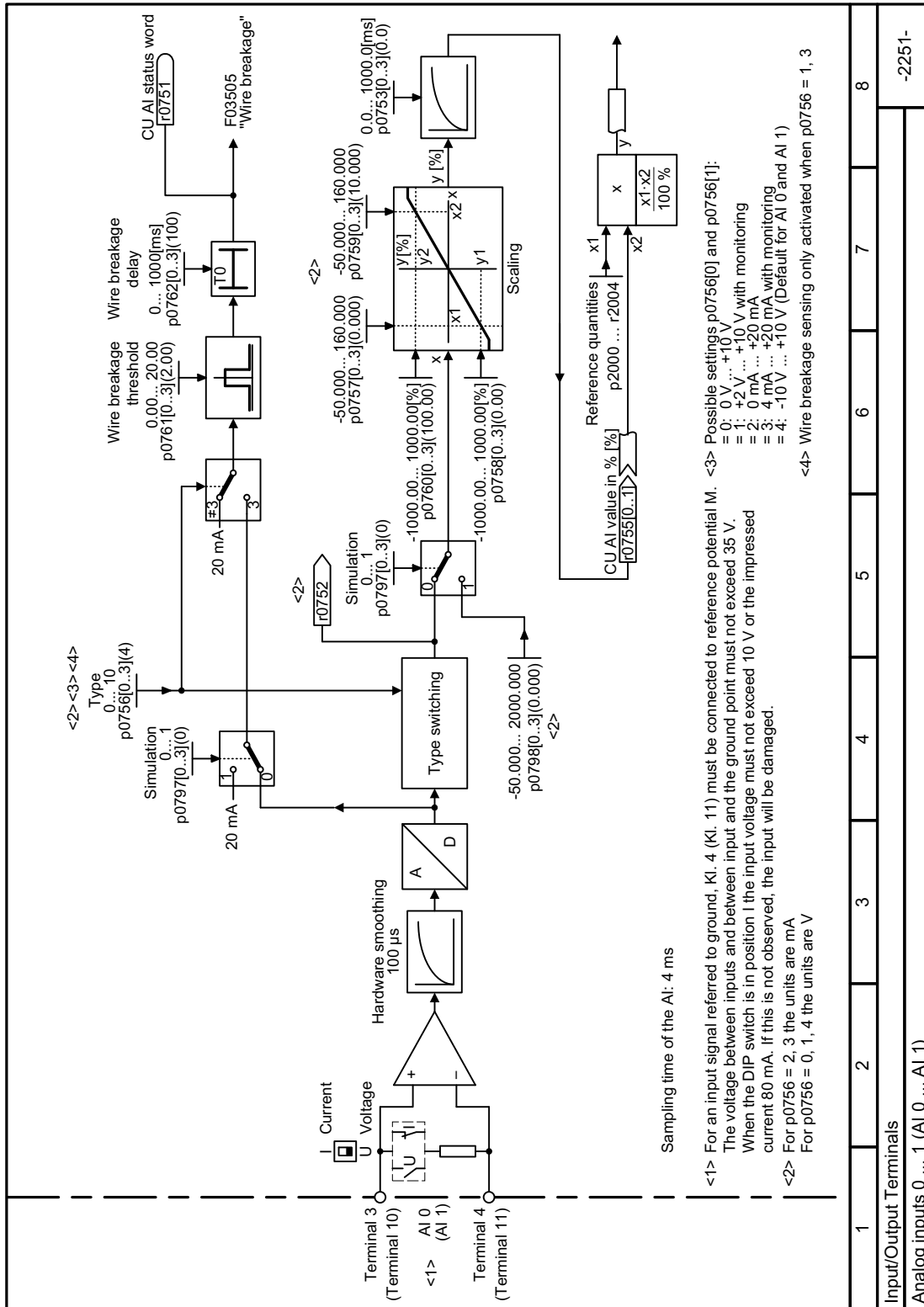
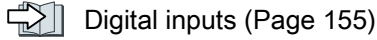

Figure 6-8 FP 2251

More information

Using an analog input as a digital input

An analog input can also be used as a digital input.



6.2.2.5 Adjusting characteristics for analog input

Function description

If you change the analog input type using p0756, then the converter automatically selects the appropriate scaling of the analog input. The linear scaling characteristic is defined using two points (p0757, p0758) and (p0759, p0760). Parameters p0757 ... p0760 are assigned to an analog input via their index, e.g. parameters p0757[0] ... p0760[0] belong to analog input 0.

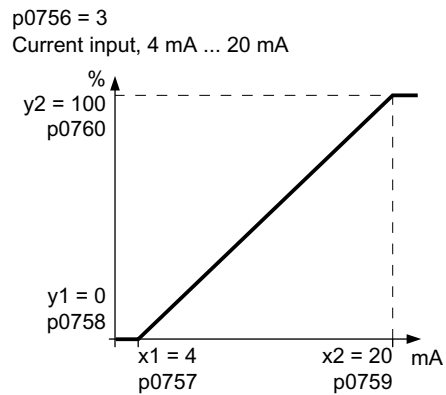
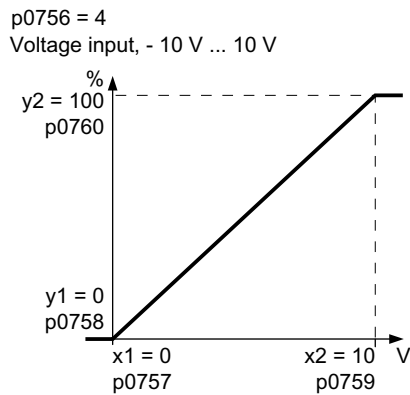

You must define your own characteristic if none of the default types match your particular application.

Example

The converter should convert a 6 mA ... 12 mA signal into the value range -100% ... 100% via analog input 0. The wire-break monitoring of the converter should respond when 6 mA is fallen below.

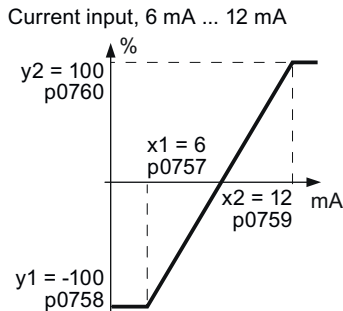

**Procedure**

1. Set the DIP switch for analog input 0 on the Control Unit to current input ("I").



2. set p0756[0] = 3  
You have defined analog input 0 as a current input with wire-break monitoring.
3. Set p0757[0] = 6.0 (x1)
4. Set p0758[0] = -100.0 (y1)
5. Set p0759[0] = 12.0 (x2)
6. Set p0760[0] = 100.0 (y2)
7. Set p0761[0] = 6  
An input current < 6 mA results in fault F03505.

The characteristic for the application example is set.

**Parameters**

Parameter	Description	Factory setting
p0757[0...1]	CU analog inputs characteristic value x1	0
p0758[0...1]	CU analog inputs characteristic value y1	0%
p0759[0...1]	CU analog inputs characteristic value x2	10
p0760[0...1]	CU analog inputs characteristic value y2	100%
p0761[0...1]	CU analog inputs wire-break monitoring, response threshold	2

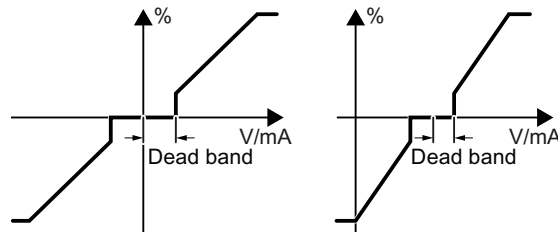
**6.2.2.6 Setting the deadband****Function description**

With the control enabled, electromagnetic interference on the signal cable can cause the motor to slowly rotate in one direction in spite of a speed setpoint = 0.

The deadband acts on the zero crossover of the analog input characteristic. Internally, the converter sets its speed setpoint = 0, even if the signal at the analog input terminals is slightly positive or negative. This prevents the converter from rotating the motor when the speed setpoint = 0.

## Parameters

Parameter	Description	Factory setting
p0764[0]	Analog inputs deadband, AI 0	0
p0764[1]	Analog inputs deadband, AI 1	0

## 6.2.2.7 Analog outputs

### Function description

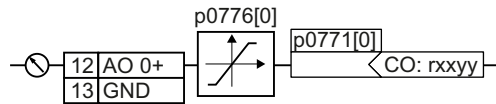

#### Defining the analog output type

Define the analog output type using parameter p0776.

The converter offers a series of default settings, which you can select using parameter p0776:

AO 0	Current output (factory setting)	0 mA ... +20 mA	p0776[0] =	0
	Voltage output	0 V ... +10 V		1
	Current output	+4 mA ... +20 mA		2

#### Defining the function of an analog output

Connector outputs are designated with "CO".

You define the analog output function by interconnecting parameter p0771 with a connector output of your choice. Parameter p0771 is assigned to the particular analog output via its index, e.g. parameter p0771[0] is assigned to analog output 0.

### Example

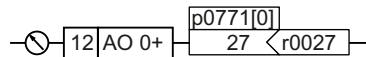

To output the converter output current via analog output 0, you must interconnect AO 0 with the signal for the output current.

Set p0771 = 27.

### Parameters

Table 6-6 Frequently used connector outputs (CO) of the converter

Parameter	Description	Factory setting
r0021	CO: Speed actual value, smoothed	- rpm
r0025	CO: Output voltage, smoothed	- Vrms
r0026	CO: DC link voltage, smoothed	- V
r0027	CO: Absolute actual current, smoothed	- Arms
r0063	CO: Speed actual value	- rpm

You can find additional connector outputs in the parameter list.

 Parameter list (Page 376)



### 6.2.2.8 Adjusting characteristics for analog output

#### Function description

If you change the analog output type, then the converter automatically selects the appropriate scaling of the analog output. The linear scaling characteristic is defined using two points (p0777, p0778) and (p0779, p0780).

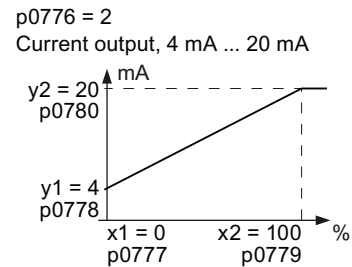
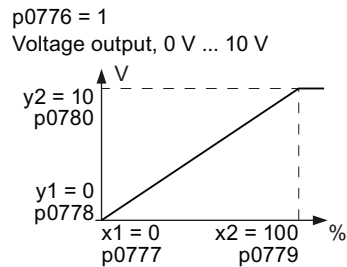

Parameters p0777 ... p0780 are assigned to an analog output via their index, e.g. parameters p0777[0] ... p0770[0] belong to analog output 0.

You must define your own characteristic if none of the default types match your particular application.

#### Example

Via analog output 0, the converter should convert a signal in the value range 0% ... 100% into an output signal 6 mA ... 12 mA.

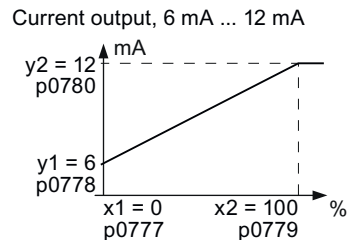

#### Procedure

1. Set p0776[0] = 2  
This defines analog output 0 as a current output.
2. Set p0777[0] = 0.0 (x1)
3. Set p0778[0] = 6.0 (y1)
4. Set p0779[0] = 100.0 (x2)
5. Set p0780[0] = 12.0 (y2)

The characteristic for the application example is set.

□

Parameters

Table 6-7 Parameters for the scaling characteristic

Parameter	Description	Factory setting
p0777[0...1]	CU analog outputs characteristic value x1	-
p0778[0...1]	CU analog outputs characteristic value y1	0 V
p0779[0...1]	CU analog outputs characteristic value x2	100%
p0780[0...1]	CU analog outputs characteristic value y2	20 V

6.2.3 Drive control via PROFINET

6.2.3.1 Receive data and send data

Overview

Cyclic data exchange



The converter receives cyclic data from the higher-level control - and returns cyclic data to the control.

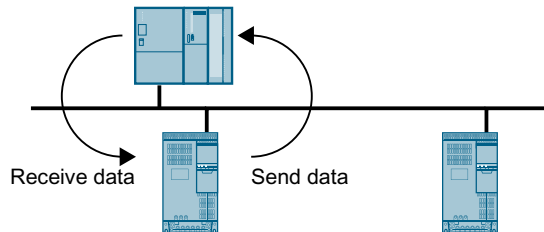

Figure 6-10 Cyclic data exchange

Converter and higher-level control system package their data in the form of telegrams.

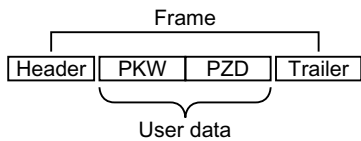

Figure 6-11 Telegram structure



A telegram has the following structure:

- Header and trailer form the protocol frame.
- User data is located within the frame:
  - PKW: The control system can read or change the parameters in the converter via "PKW data".  
Not every telegram has a "PKW range".
  - PZD: The converter receives control commands and setpoints from the higher-level control - and sends status messages and actual values via "PZD data".

### PROFIdrive and telegram numbers

For typical applications, certain telegrams are defined in the PROFIdrive profile and are assigned a fixed PROFIdrive telegram number. As a consequence, behind a PROFIdrive telegram number, there is a defined signal composition. As a consequence, a telegram number uniquely describes cyclic data exchange.

The telegrams are identical for PROFIBUS and PROFINET.

## 6.2.3.2 Telegrams

### Overview

The user data of the telegrams that are available are described in the following.

Telegram 1

PZD01	PZD02	
STW1	NSOLL_A	Receive user data
ZSW1	NIST_A	Send user data

16-bit speed setpoint

Telegram 20

PZD01	PZD02	PZD03	PZD04	PZD05	PZD06
STW1	NSOLL_A				
ZSW1	NIST_A GLATT	IAIST_ GLATT	MIST_ GLATT	PIST_ GLATT	MELD_ NAMUR

16-bit speed setpoint for VIK-Namur

Telegram 350

PZD01	PZD02	PZD03	PZD04
STW1	NSOLL_A	M_LIM	STW3
ZSW1	NIST_A GLATT	IAIST_ GLATT	ZSW3

16-bit speed setpoint with torque limiting

6.2 Drive control

Telegram 352

PZD01	PZD02	PZD03	PZD04	PZD05	PZD06
STW1	NSOLL_A	Freely assignable			
ZSW1	NIST_A GLATT	IAIST_ GLATT	MIST_ GLATT	WARN_ CODE	FAULT_ CODE

16-bit speed setpoint for PCS7

Telegram 353

	PZD01	PZD02
PKW	STW1	NSOLL_A
	ZSW1	NIST_A GLATT

16-bit speed setpoint with reading and writing to parameters

Telegram 354

	PZD01	PZD02	PZD03	PZD04	PZD05	PZD06
PKW	STW1	NSOLL_A	Freely assignable			
	ZSW1	NIST_A GLATT	IAIST_ GLATT	MIST_ GLATT	WARN_ CODE	FAULT_ CODE

16-bit speed setpoint for PCS7 with reading and writing to parameters

Telegram 999

PZD01	PZD02	PZD03	PZD04	PZD05	PZD06	PZD07	PZD08	PZD09	PZD10	PZD11	PZD12	PZD13 ... PZD17
STW1	Telegram length for the receive data											
ZSW1	Telegram length for the transmit data											

Unassigned interconnection and length

Table 6-8 Abbreviations

Abbreviation	Explanation	Abbreviation	Explanation
PZD	Process data	PKW	Parameter channel
STW	Control word	MIST_GLATT	Actual smoothed torque
ZSW	Status word	PIST_GLATT	Actual smoothed active power
NSOLL_A	Speed setpoint	M_LIM	Torque limit value
NIST_A	Speed actual value	FAULT_CODE	Fault code
NIST_A_GLATT	Smoothed actual speed value	WARN_CODE	Alarm code
IAIST_GLATT	Smoothed current actual value	MELD_NAMUR	Message according to the VIK-NAMUR definition

## Function description

## Control word 1 (STW1)

Bit	Significance		Explanation	Signal inter-connection in the converter
	Telegram 20	All other telegrams		
0	0 = OFF1		The motor brakes with the ramp-down time p1121 of the ramp-function generator. The converter switches off the motor at standstill.	p0840[0] = r2090.0
	0 → 1 = ON		The converter goes into the "ready" state. If, in addition bit 3 = 1, then the converter switches on the motor.	
1	0 = OFF2		Switch off the motor immediately, the motor then coasts down to a standstill.	p0844[0] = r2090.1
	1 = No OFF2		The motor can be switched on (ON command).	
2	0 = Quick stop (OFF3)		Quick stop: The motor brakes to a standstill with the OFF3 ramp-down time p1135.	p0848[0] = r2090.2
	1 = No quick stop (OFF3)		The motor can be switched on (ON command).	
3	0 = Inhibit operation		Immediately switch-off motor (cancel pulses).	p0852[0] = r2090.3
	1 = Enable operation		Switch-on motor (pulses can be enabled).	
4	0 = Disable RFG		The converter immediately sets its ramp-function generator output to 0.	p1140[0] = r2090.4
	1 = Do not disable RFG		The ramp-function generator can be enabled.	
5	0 = Stop RFG		The output of the ramp-function generator stops at the actual value.	p1141[0] = r2090.5
	1 = Enable RFG		The output of the ramp-function generator follows the setpoint.	
6	0 = Inhibit setpoint		The converter brakes the motor with the ramp-down time p1121 of the ramp-function generator.	p1142[0] = r2090.6
	1 = Enable setpoint		Motor accelerates to the setpoint with the ramp-up time p1120.	
7	0 → 1 = Acknowledge faults		Acknowledge fault. If the ON command is still active, the converter switches to the "switching on inhibited" state.	p2103[0] = r2090.7
8, 9	Reserved			
10	0 = No control via PLC		Converter ignores the process data from the fieldbus.	p0854[0] = r2090.10
	1 = Control via PLC		Control via fieldbus, converter accepts the process data from the fieldbus.	
11	1 = Direction reversal		Invert setpoint in the converter.	p1113[0] = r2090.11
12	Not used			
13	--- <sup>1)</sup>	1 = MOP up	Increase the setpoint saved in the motorized potentiometer.	p1035[0] = r2090.13

Bit	Significance		Explanation	Signal inter-connection in the converter
	Telegram 20	All other telegrams		
14	--- <sup>1)</sup>	1 = MOP down	Reduce the setpoint saved in the motorized potentiometer.	p1036[0] = r2090.14
15	CDS bit 0	Reserved	Changes over between settings for different operation interfaces (command data sets).	p0810 = r2090.15

<sup>1)</sup> If you change over from another telegram to telegram 20, then the assignment of the previous telegram is kept.

**Status word 1 (ZSW1)**

Bit	Significance		Remarks	Signal inter-connection in the converter
	Telegram 20	All other telegrams		
0	1 = Ready for switching on		Power supply switched on; electronics initialized; pulses locked.	p2080[0] = r0899.0
1	1 = Ready		Motor is switched on (ON/OFF1 = 1), no fault is active. With the command "Enable operation" (STW1.3), the converter switches on the motor.	p2080[1] = r0899.1
2	1 = Operation enabled		Motor follows setpoint. See control word 1, bit 3.	p2080[2] = r0899.2
3	1 = Fault active		The converter has a fault. Acknowledge fault using STW1.7.	p2080[3] = r2139.3
4	1 = OFF2 inactive		Coast down to standstill is not active.	p2080[4] = r0899.4
5	1 = OFF3 inactive		Quick stop is not active.	p2080[5] = r0899.5
6	1 = Switching on inhibited active		It is only possible to switch on the motor after an OFF1 followed by ON.	p2080[6] = r0899.6
7	1 = Alarm active		Motor remains switched on; no acknowledgement is necessary.	p2080[7] = r2139.7
8	1 = Speed deviation within the tolerance range		Setpoint / actual value deviation within the tolerance range.	p2080[8] = r2197.7
9	1 = Master control requested		The automation system is requested to accept the converter control.	p2080[9] = r0899.9
10	1 = Comparison speed reached or exceeded		Speed is greater than or equal to the corresponding maximum speed.	p2080[10] = r2199.1
11	1 = current or torque limit reached	1 = torque limit reached	Comparison value for current or torque has been reached or exceeded.	p2080[11] = r0056.13 / r1407.7
12	--- <sup>1)</sup>	1 = Holding brake open	Signal to open and close a motor holding brake.	p2080[12] = r0899.12
13	0 = Alarm, motor overtemperature		--	p2080[13] = r2135.14

Bit	Significance		Remarks	Signal interconnection in the converter
	Telegram 20	All other telegrams		
14	1 = Motor rotates clockwise		Internal converter actual value > 0.	p2080[14] = r2197.3
	0 = Motor rotates counter-clockwise		Internal converter actual value < 0.	
15	1 = CDS display	0 = Alarm, converter thermal overload		p2080[15] = r0836.0 / r2135.15

<sup>1)</sup> If you change over from another telegram to telegram 20, then the assignment of the previous telegram is kept.

### Control word 3 (STW3)

Bit	Significance		Explanation	Signal interconnection in the converter <sup>1)</sup>
	Telegram 350			
0	1 = fixed setpoint bit 0		Selects up to 16 different fixed setpoints.	p1020[0] = r2093.0
1	1 = fixed setpoint bit 1			p1021[0] = r2093.1
2	1 = fixed setpoint bit 2			p1022[0] = r2093.2
3	1 = fixed setpoint bit 3			p1023[0] = r2093.3
4	1 = DDS selection bit 0		Changes over between settings for different motors (drive data sets).	p0820 = r2093.4
5	1 = DDS selection bit 1			p0821 = r2093.5
6	Not used			
7	Not used			
8	1 = technology controller enable		--	p2200[0] = r2093.8
9	1 = enable DC braking		--	p1230[0] = r2093.9
10	Not used			
11	1 = Enable droop		Enable or inhibit speed controller droop.	p1492[0] = r2093.11
12	1 = torque control active 0 = speed control active		Changes over the control mode for vector control.	p1501[0] = r2093.12
13	1 = no external fault 0 = external fault is active (F07860)		--	p2106[0] = r2093.13
14	Not used			
15	1 = CDS bit 1		Changes over between settings for different operation interfaces (command data sets).	p0811[0] = r2093.15

<sup>1)</sup> If you switch from telegram 350 to a different one, then the converter sets all interconnections p1020, ... to "0". Exception: p2106 = 1.

**Status word 3 (ZSW3)**

Bit	Significance	Description	Signal interconnection in the converter
0	1 = DC braking active	--	p2051[3] = r0053
1	1 = $ n_{act}  > p1226$	Absolute current speed > stationary state detection	
2	1 = $ n_{act}  > p1080$	Absolute actual speed > minimum speed	
3	1 = $i_{act} \geq p2170$	Actual current $\geq$ current threshold value	
4	1 = $ n_{act}  > p2155$	Absolute actual speed > speed threshold value 2	
5	1 = $ n_{act}  \leq p2155$	Absolute actual speed < speed threshold value 2	
6	1 = $ n_{act}  \geq r1119$	Speed setpoint reached	
7	1 = DC link voltage $\leq p2172$	Actual DC link voltage $\leq$ threshold value	
8	1 = DC link voltage > p2172	Actual DC link voltage > threshold value	
9	1 = ramp-up or ramp-down completed	Ramp-function generator is not active.	
10	1 = technology controller output at the lower limit	Technology controller output $\leq p2292$	
11	1 = technology controller output at the upper limit	Technology controller output > p2291	
12	Not used		
13	Not used		
14	Not used		
15	Not used		

**Fault word according to the VIK-NAMUR definition (MELD\_NAMUR)**

Bit	Significance	P no.
0	1 = Control Unit signals a fault	p2051[5] = r3113
1	1 = line fault: Phase failure or inadmissible voltage	
2	1 = DC link overvoltage	
3	1 = Power Module fault, e.g. overcurrent or overtemperature	
4	1 = converter overtemperature	
5	1 = ground fault/phase fault in the motor cable or in the motor	
6	1 = motor overload	
7	1 = communication error to the higher-level control system	
8	1 = fault in a safety-relevant monitoring channel	
10	1 = fault in the internal converter communication	
11	1 = line fault	
15	1 = other fault	

**See also**

Expanding or freely interconnecting telegrams (Page 187)

Parameters (Page 373)

### 6.2.3.3 Parameter channel

#### Overview

The parameter channel allows parameter values to be cyclically read and written to.

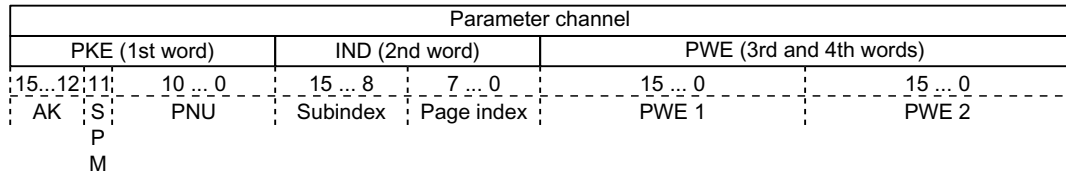

Structure of the parameter channel:

- PKE (1st word)
  - Type of task (read or write).
  - Bit 11 is reserved and is always assigned 0.
  - Parameter number
- IND (2nd word)
  - Parameter index
- PWE (3rd and 4th word)
  - Parameter value

#### Function description

##### AK: Request and response ID

Table 6-9 Request identifiers, control → converter

AK	Description	Response identifier	
		positive	negative
0	No request	0	7 / 8
1	Request parameter value	1 / 2	7 / 8
2	Change parameter value (word)	1	7 / 8
3	Change parameter value (double word)	2	7 / 8
4	Request descriptive element <sup>1)</sup>	3	7 / 8
6 <sup>2)</sup>	Request parameter value (field) <sup>1)</sup>	4 / 5	7 / 8
7 <sup>2)</sup>	Change parameter value (field, word) <sup>1)</sup>	4	7 / 8
8 <sup>2)</sup>	Change parameter value (field, double word) <sup>1)</sup>	5	7 / 8
9	Request number of field elements	6	7 / 8

<sup>1)</sup> The required element of the parameter is specified in IND (2nd word).

<sup>2)</sup> The following request IDs are identical: 1 ≡ 6, 2 ≡ 7 and 3 ≡ 8.  
We recommend that you use identifiers 6, 7 and 8.



Table 6-10 Response identifiers, converter → control

AK	Description
0	No response
1	Transfer parameter value (word)
2	Transfer parameter value (double word)
3	Transfer descriptive element <sup>1)</sup>
4	Transfer parameter value (field, word) <sup>2)</sup>
5	Transfer parameter value (field, double word) <sup>2)</sup>
6	Transfer number of field elements
7	Converter cannot process the request. In the most significant word of the parameter channel, the converter sends an error number to the control, refer to the following table.
8	No master controller status / no authorization to change parameters of the parameter channel interface

<sup>1)</sup> The required element of the parameter is specified in IND (2nd word).

<sup>2)</sup> The required element of the indexed parameter is specified in IND (2nd word).

Table 6-11 Error numbers for response identifier 7

No.	Description
00 hex	<b>Illegal parameter number</b> (access to a parameter that does not exist)
01 hex	<b>Parameter value cannot be changed</b> (change request for a parameter value that cannot be changed)
02 hex	<b>Lower or upper value limit exceeded</b> (change request with a value outside the value limits)
03 hex	<b>Incorrect subindex</b> (access to a subindex that does not exist)
04 hex	<b>No array</b> (access with a subindex to non-indexed parameters)
05 hex	<b>Incorrect data type</b> (change request with a value that does not match the data type of the parameter)
06 hex	<b>Setting not permitted, only resetting</b> (change request with a value not equal to 0 without permission)
07 hex	<b>Descriptive element cannot be changed</b> (change request to a descriptive element error value that cannot be changed)
0B hex	<b>No master control</b> (change request but with no master control, see also p0927)
0C hex	<b>Keyword missing</b>
11 hex	<b>Request cannot be executed due to the operating state</b> (access is not possible for temporary reasons that are not specified)
14 hex	<b>Inadmissible value</b> (change request with a value that is within the limits but which is illegal for other permanent reasons, i.e. a parameter with defined individual values)
65 hex	<b>Parameter number is currently deactivated</b> (depending on the mode of the converter)
66 hex	<b>Channel width is insufficient</b> (communication channel is too small for response)
68 hex	<b>Illegal parameter value</b> (parameter can only assume certain values)
6A hex	<b>Request not included / task is not supported</b> (the valid request identifications can be found in table "Request identifications controller → converter")
6B hex	<b>No change access for a controller that is enabled.</b> (The operating state of the converter prevents a parameter change)

No.	Description
86 hex	<b>Write access only for commissioning (p0010 = 15)</b> (operating state of the converter prevents a parameter change)
87 hex	<b>Know-how protection active, access locked</b>
C8 hex	<b>Change request below the currently valid limit</b> (change request to a value that lies within the "absolute" limits, but is however below the currently valid lower limit)
C9 hex	<b>Change request above the currently valid limit</b> (example: a parameter value is too large for the converter power)
CC hex	<b>Change request not permitted</b> (change is not permitted as the access code is not available)

**PNU (parameter number) and page index**

Parameter number	PNU	Page index
0000 ... 1999	0000 ... 1999	0 hex
2000 ... 3999	0000 ... 1999	80 hex
6000 ... 7999	0000 ... 1999	90 hex
8000 ... 9999	0000 ... 1999	20 hex
10000 ... 11999	0000 ... 1999	A0 hex
20000 ... 21999	0000 ... 1999	50 hex
30000 ... 31999	0000 ... 1999	F0 hex
60000 ... 61999	0000 ... 1999	74 hex

**Subindex**

For indexed parameters, the parameter index is located in subindex as hexadecimal value.

**PWE: Parameter value or connector**

Parameter values or connectors can be located in the PWE.

Table 6-12 Parameter value or connector

	PWE 1	PWE 2	
Parameter value	Bit 15 ... 0	Bit 15 ... 8	Bit 7 ... 0
	0	0	8-bit value
	0	16-bit value	
	32-bit value		
Connector	Bit 15 ... 0	Bit 15 ... 10	Bit 9 ... 0
	Number of the connector	3F hex	The index or bit field number of the connector



6.2 Drive control

- **IND, bit 0 ... 7 (page index): = 0 hex** (offset 0 corresponds to 0 hex)
- **PWE1, Bit 0 ... 15: = 2D2 hex** (722 = 2D2 hex)
- **PWE2, Bit 10 ... 15: = 3F hex** (drive object - for SINAMICS G120, always 63 = 3f hex)
- **PWE2, Bit 0 ... 9: = 2 hex** (Index of Parameter (DI 2 = 2))

Parameter channel																																									
PKE, 1st word				IND, 2nd word				PWE1 - high, 3rd word				PWE2 - low, 4th word																													
15...12	11	10 ... 0		15 ... 8	7 ... 0			15 ... 0				15 ... 10	9 ... 0																												
AK	Parameter number			Subindex	Page index			Parameter value				Drive Object	Index																												
0	1	1	1	0	0	1	1	0	1	0	0	1	0	0	0	0	0	0	0	0	0	1	0	0	0	0	0	0	0	0	0	0	0	0	0	0	0	0	0	1	0

Figure 6-14 Parameter channel to assign digital input 2 with ON/OFF1

### 6.2.3.4 Expanding or freely interconnecting telegrams

#### Overview

When you have selected a telegram, the converter interconnects the corresponding signals with the fieldbus interface. Generally, these interconnections are locked so that they cannot be changed. However, with the appropriate setting in the converter, the telegram can be extended or even freely interconnected.

#### Precondition

##### Expanding a telegram: Procedure

1. Set p0922 = 999.
2. Set parameter p2079 to the value of the corresponding telegram.

You have created the preconditions to expand a telegram.

##### Freely interconnecting signals in the telegram: Procedure

1. Set p0922 = 999.
2. Set p2079 = 999.

You have created the precondition to freely interconnect the signals transferred in the telegram.

#### Function description

##### Interconnection of the process data

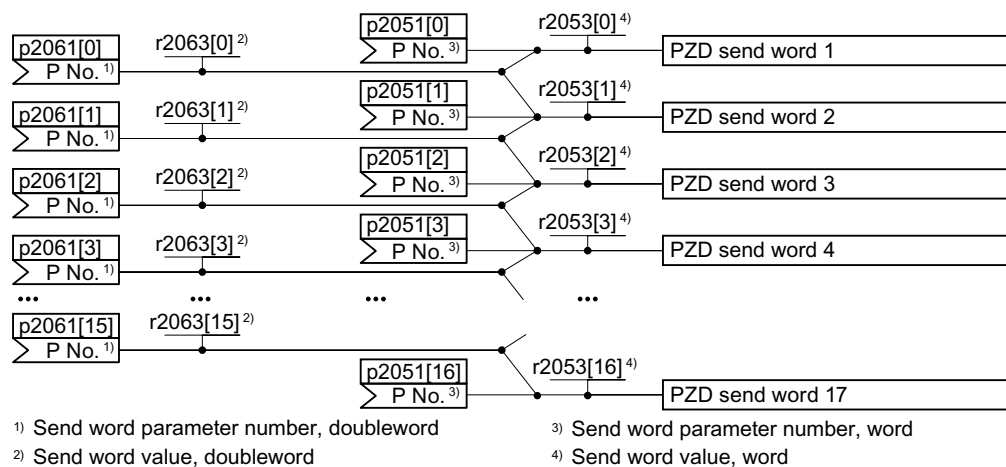

Figure 6-15 Interconnection of the send data

In the converter, the send data are available in the "Word" format (p2051) - and in the "Double word" format (p2061). If you set a specific telegram, or you change the telegram, then the converter automatically interconnects parameters p2051 and p2061 with the appropriate signals.

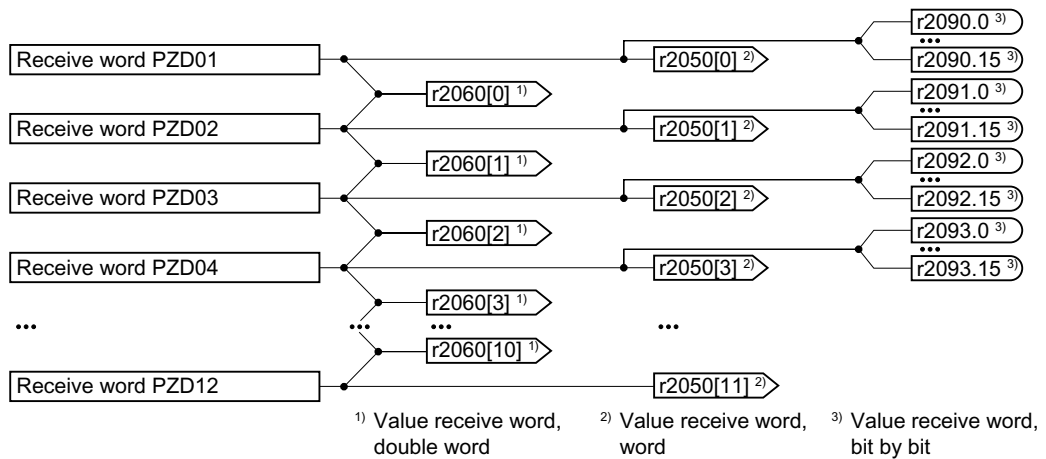

Figure 6-16 Interconnection of the receive data

The converter saves the receive data as follows:

- "Word" format in r2050
- "Double word" format in r2060
- Bit-by-bit in r2090 ...r2093)

**Extending the telegram**

Extend the telegram by "attaching" additional signals.

Interconnect additional PZD send words and PZD receive words with signals of your choice via parameters r2050 and p2051.

**Freely interconnecting signals in the telegram**

Interconnect additional PZD send words and PZD receive words with signals of your choice via parameters r2050 and p2051.

**Parameter**

Number	Name	Factory setting
p0922	PROFIdrive PZD telegram selection	1
r2050[0...11]	CO: PROFIdrive PZD receive word	-
p2051[0...16]	CI: PROFIdrive PZD send word	0 or dependent on the converter
r2053[0...16]	PROFIdrive diagnostics send PZD word	-
r2060[0...10]	CO: PROFIdrive PZD receive double word	-
p2061[0...15]	CI: PROFIdrive PZD send double word	0
r2063[0...15]	PROFIdrive diagnostics PZD send double word	-
p2079	PROFIdrive PZD telegram selection extended	1

Number	Name	Factory setting
p2080[0...15]	BI: Binector-connector converter, status word 1	[0] 899 [1] 899.1 [2] 899.2 [3] 2139.3 [4] 899.4 [5] 899.5 [6] 899.6 [7] 2139.7 [8] 2197.7 [9] 899.9 [10] 2199.1 [11] 1407.7 [12] 0 [13] 2135.14 [14] 2197.3 [15] 2135.15
r2090.0...15	BO: PROFIdrive receive PZD1 bit by bit	-
r2091.0...15	BO: PROFIdrive PZD2 receive bit-serial	-
r2092.0...15	BO: PROFIdrive PZD3 receive bit-serial	-
r2093.0...15	BO: PROFIdrive PZD4 receive bit-serial	-

### 6.2.3.5 Acyclically reading and writing converter parameters

#### Overview

The converter supports the writing and reading of parameters via acyclic communication.

### 6.2.3.6 Reading and changing parameters via data set 47

#### Note

##### Values in italics

Values in italics in the following tables mean that you have to adjust these values for a specific request.

### Reading parameter values

Table 6-13 Request to read parameters

Data block	Byte n	Bytes n + 1	n
Header	Reference <i>01 hex ... FF hex</i>	01 hex: Read job	0
	01 hex (ID of drive objects, at G120 always = 1)	Number of parameters (m)	2

6.2 Drive control

Data block	Byte n	Bytes n + 1	n
Address, parameter 1	<b>Attribute</b> 10 hex: Parameter value 20 hex: Parameter description	<b>Number of the indices</b> 00 hex ... EA hex (For parameters without index: 00 hex)	4
	<b>Parameter number</b> 0001 hex ... FFFE hex		6
	<b>Number of the 1st index</b> 0000 hex ... FFFF hex (for parameters without index: 0000 hex)		8
	...		...
Address, parameter 2	...		...
...	...		...
Address, parameter m	...		...

Table 6-14 Converter response to a read request

Data block	Byte n	Bytes n + 1	n
Header	<b>Reference</b> (identical to a read request)	<b>01 hex:</b> Converter has executed the read request. <b>81 hex:</b> Converter was not able to completely execute the read request.	0
	<b>01 hex</b> (ID of drive objects, at G120 always = 1)	<b>Number of parameters (m)</b> (identical to the read request)	2
Values, parameter 1	<b>Format</b> 02 hex: Integer8 03 hex: Integer16 04 hex: Integer32 05 hex: Unsigned8 06 hex: Unsigned16 07 hex: Unsigned32 08 hex: FloatingPoint 0A hex: OctetString 0D hex: TimeDifference 34 hex: TimeOfDay without date indication 35 hex: TimeDifference with date indication 36 hex: TimeDifference without date indication 41 hex: Byte 42 hex: Word 43 hex: Double word 44 hex: Error	<b>Number of index values</b> or - for a negative response - <b>number of error values</b>	4
	<b>Value of the 1st index</b> or - for a negative response - <b>error value 1</b> You can find the error values in a table at the end of this section.		6
	...		...
Values, parameter 2	...		
...	...		
Values, parameter m	...		



## Changing parameter values

Table 6-15 Request to change parameters

Data block	Byte n	Bytes n + 1	n
Header	<b>Reference</b> 01 hex ... FF hex	<b>02 hex:</b> Change request	0
	<b>01 hex</b> (ID of drive objects, at G120 always = 1)	<b>Number of parameters (m)</b> 01 hex ... 27 hex	2
Address, parameter 1	<b>10 hex:</b> Parameter value	<b>Number of indices</b> 00 hex ... EA hex (00 hex and 01 hex are equivalents)	4
	<b>Parameter number</b> 0001 hex ... FFFF hex		6
	<b>Number of the 1st index</b> 0001 hex ... FFFE hex		8
	...		...
Address, parameter 2	...		...
...	...		...
Address, parameter m	...		
Values, parameter 1	<b>Format</b> 02 hex: Integer 8 03 hex: Integer 16 04 hex: Integer 32 05 hex: Unsigned 8 06 hex: Unsigned 16 07 hex: Unsigned 32 08 hex: Floating Point 0A hex: Octet String 0D hex: Time Difference 34 hex: TimeOfDay without date indication 35 hex: TimeDifference with date indication 36 hex: TimeDifference without date indication 41 hex: Byte 42 hex: Word 43 hex: Double word	<b>Number of index values</b> 00 hex ... EA hex	
	<b>Value of the 1st index</b>		
	...		
Values, parameter 2	...		
...	...		
Values, parameter m	...		

Table 6-16 Response, if the converter has executed the change request

Data block	Byte n	Bytes n + 1	n
Header	<b>Reference</b> (identical to a change request)	<b>02 hex</b> (change request successful)	0
	<b>01 hex</b> (ID of drive objects, at G120 always = 1)	<b>Number of parameters</b> (identical to a change request)	2



Table 6-17 Response if the converter was not able to completely execute the change request

Data block	Byte n	Bytes n + 1	n
Header	Reference (identical to a change request)	<b>82 hex:</b> (Converter was not able to completely execute the write request)	0
	<b>01 hex</b> (ID of drive objects, at G120 always = 1)	<b>Number of parameters</b> (identical to a change request)	2
Values, parameter 1	<b>Format</b> 40 hex: Zero (change request for this data block executed) 44 hex: Error (change request for this data block not executed)	<b>Number of error values</b> 00 hex 01 hex or 02 hex	4
	Only for "Error" - <b>error value 1</b> You can find the error values in the table at the end of this section.		6
	Only for "Error" - <b>error value 2</b> Error value 2 is either zero, or it contains the number of the first index where the error occurred.		8
Values, parameter 2	...		
...	...		...
Values, parameter m	...		

### Error values

Table 6-18 Error value in the parameter response

Error value 1	Significance
00 hex	<b>Illegal parameter number</b> (access to a parameter that does not exist)
01 hex	<b>Parameter value cannot be changed</b> (change request for a parameter value that cannot be changed)
02 hex	<b>Lower or upper value limit exceeded</b> (change request with a value outside the value limits)
03 hex	<b>Incorrect subindex</b> (access to a parameter index that does not exist)
04 hex	<b>No array</b> (access with a subindex to non-indexed parameters)
05 hex	<b>Incorrect data type</b> (change request with a value that does not match the data type of the parameter)
06 hex	<b>Setting not permitted, only resetting</b> (change request with a value not equal to 0 without permission)
07 hex	<b>Descriptive element cannot be changed</b> (change request to a descriptive element that cannot be changed)
09 hex	<b>Description data not available</b> (access to a description that does not exist, parameter value is available)
0B hex	<b>No master control</b> (change request but with no master control)
0F hex	<b>Text array does not exist</b> (although the parameter value is available, the request is made to a text array that does not exist)
11 hex	<b>Request cannot be executed due to the operating state</b> (access is not possible for temporary reasons that are not specified)
14 hex	<b>Inadmissible value</b> (change request with a value that is within the limits but which is illegal for other permanent reasons, i.e. a parameter with defined individual values)
15 hex	<b>Response too long</b> (the length of the actual response exceeds the maximum transfer length)
16 hex	<b>Illegal parameter address</b> (illegal or unsupported value for attribute, number of elements, parameter number, subindex or a combination of these)
17 hex	<b>Illegal format</b> (change request for an illegal or unsupported format)
18 hex	<b>Number of values not consistent</b> (number of values of the parameter data to not match the number of elements in the parameter address)

Error value 1	Significance
19 hex	<b>Drive object does not exist</b> (access to a drive object that does not exist)
20 hex	<b>Parameter text cannot be changed</b>
21 hex	<b>Service is not supported</b> (illegal or not support request ID).
6B hex	<b>A change request for a controller that has been enabled is not possible.</b> (The converter rejects the change request because the motor is switched on. Observe the "Can be changed" parameter attribute (C1, C2, U, T) in the parameter list.  Parameters (Page 373)
6C hex	<b>Unknown unit.</b>
6E hex	<b>Change request is only possible when the motor is being commissioned (p0010 = 3).</b>
6F hex	<b>Change request is only possible when the power unit is being commissioned (p0010 = 2).</b>
70 hex	<b>Change request is only possible for quick commissioning (basic commissioning) (p0010 = 1).</b>
71 hex	<b>Change request is only possible if the converter is ready (p0010 = 0).</b>
72 hex	<b>Change request is only possible for a parameter reset (restore to factory setting) (p0010 = 30).</b>
73 hex	<b>Change request possible only during commissioning of the safety functions (p0010 = 95).</b>
74 hex	<b>Change request is only possible when a technological application/unit is being commissioned (p0010 = 5).</b>
75 hex	<b>Change request is only possible in a commissioning state (p0010 ≠ 0).</b>
76 hex	<b>Change request is not possible for internal reasons (p0010 = 29).</b>
77 hex	<b>Change request is not possible during download.</b>
81 hex	<b>Change request is not possible during download.</b>
82 hex	<b>Accepting the master control is inhibited via BI: p0806.</b>
83 hex	<b>Desired interconnection is not possible</b> (the connector output does not supply a float value although the connector input requires a float value)
84 hex	<b>Converter does not accept a change request</b> (converter is busy with internal calculations. See parameter r3996 in the parameter list.  Parameters (Page 373)
85 hex	<b>No access methods defined.</b>
86 hex	<b>Write access only during commissioning of the data records (p0010 = 15)</b> (operating status of the converter prevents a parameter change.)
87 hex	<b>Know-how protection active, access locked</b>
C8 hex	<b>Change request below the currently valid limit</b> (change request to a value that lies within the "absolute" limits, but is however below the currently valid lower limit)
C9 hex	<b>Change request above the currently valid limit</b> (example: a parameter value is too large for the converter power)
CC hex	<b>Change request not permitted</b> (change is not permitted as the access code is not available)

## 6.2.4 Communication via EtherNet/IP

EtherNet/IP is real-time Ethernet, and is mainly used in automation technology.

You have the following options of integrating SINAMICS G120 converters into EtherNet/IP:

- You use the SINAMICS profile
- You use the ODVA AC/DC drive profile
- You define the assemblies for the process data using the objects that are supported by the converter

 Configuring communication via EtherNet/IP (Page 195).

The pin assignment and the connectors that you require for your converter are listed in the following tables.



You can implement a line-type topology using the two sockets at the converter. You only require one of the two sockets at the beginning and end of a line.

You can use switches to realize other topologies.

### 6.2.4.1 Connect converter to EtherNet/IP

To connect the converter to a control system via Ethernet, proceed as follows:

#### Procedure

1. Connect the converter to the control system via an Ethernet cable.
2. You create an object for data exchange.  
You have the following options:
  - Load the EDS file into your controller if you want to use the ODVA profile.  
You can find the EDS file on the Internet:  
 EDS (<https://support.industry.siemens.com/cs/ww/de/view/78026217>)
  - If your controller does not accept the EDS file, or if you wish to use the SINAMICS profile, you must create a generic module in your controller:  
 Create generic I/O module (Page 210)

You have connected the converter to the control system via EtherNet/IP.

In addition, you can find a detailed description of how to connect a SINAMICS G converter to a controller via Ethernet/IP at the following link:

 Application example (<https://support.industry.siemens.com/cs/ww/en/view/82843076>)

#### Routing and shielding Ethernet cables

Information can be found on the Internet:

 EtherNet/IP (<http://www.odva.org/Home/ODVATECHNOLOGIES/EtherNetIP/EtherNetPLibrary/tabid/76/Inq/en-US/Default.aspx>)

### Commissioning the converter in an EtherNet/IP network

To commission the converter, connect the converter via the USB interface with your computer on which Startdrive has been installed.

For additional information, refer to the operating instructions of your converter.

 Manuals and technical support (Page 932)

### 6.2.4.2 What do you need for communication via EtherNet/IP?

Check the communication settings using the following questions. If you answer "Yes" to the questions, you have correctly set the communication settings and can control the converter via the fieldbus.

- Is the converter correctly connected to the EtherNet/IP?
- Is the EDS file installed in your control system?
- Have the bus interface and IP address been correctly set?
- Have the signals that the converter and the control system exchange been correctly interconnected?

### 6.2.4.3 Configuring communication via EtherNet/IP

Make the following settings in order to communicate with a higher-level control via EtherNet/IP:

#### Procedure

1. p2030: set a value of 10: Fieldbus interface protocol selection Ethernet/IP:
2. p8921: Enter the IP address. You can find the currently valid address in r8931.
3. p8923: Enter the subnet mask. You can find the currently valid subnet mask in r8933.
4. p8922: Enter the standard gateway. You can find the currently valid Default Gateway in r8932.
5. p8920: Enter the station name.
6. p8925: Set a value of 2: Save and activate PN interface configuration
7. Switch off the converter power supply.
8. Wait until all LEDs on the converter are dark.
9. Switch on the converter power supply again.  
Your settings become effective after switching on.

You have now configured the converter for communication via EtherNet/IP.

Parameters p8921 ... p8925 apply if p2030 = 10 is set, for EtherNet/IP, even if the parameter names indicates PROFINET.

## Communication settings

You set the communication using parameter p8980. You have the following options

### Communication via the SINAMICS profile

The SINAMICS profile is a drive profile for EtherNet/IP defined by Siemens, based on PROFIdrive, and is factory set in the converters.

Setting: p8980 = 0

With the SINAMICS profile, you can use each of the telegrams listed in parameter p0922

**Communication via the ODVA AC/DC drive profile**

The ODVA AC/DC drive profile is a drive profile defined by the ODVA organization

Setting: p8980 = 1

With the AC/DC profile of ODVA, you select the standard telegram, p0922 = 1

**Communication settings via EtherNet/IP objects and assemblies**

If you are using assemblies, which are described in the "Supported objects"  Supported objects (Page 196)), then you must integrate the converter yourself into the control system. Details on this topic can be found in the documentation of your control system.

**Special issues if you wish to use the ODVA AC/DC Drive profile**

You must switch the converter power supply off and switch it on again if you wish to change the following parameters so that the changes become effective.

**Setting the off response for the motor**

You set the standard off response for the converter using parameter p8981:

- p8981 = 0: OFF1 (factory setting), also corresponds to the setting in the SINAMICS profile
- p8981 = 1: OFF2

**Setting the speed and torque scaling**

You scale the speed and torque display using parameter p8982 or p8983. Setting range: 2<sup>5</sup> to 2<sup>-5</sup>.

**Displaying the maximum process data that can be transferred (PZD)**

- r2067[0] maximum interconnected PZD length - receiving
- r2067[1] maximum interconnected PZD length - sending

**6.2.4.4 Supported objects**

**Overview**

Object class		Object name	Objects re-quired	ODVA objects	SINAMICS objects
hex	dec				
1 hex	1	Identity object	x		
4 hex	4	Assembly Object	x		
6 hex	6	Connection Management Object	x		
28 hex	40	Motor Data Object		x	
29 hex	41	Supervisor Object		x	
2A hex	42	Drive Object		x	
32C hex	812	Siemens Drive Object			x
32D hex	813	Siemens Motor Data Object			x
F5 hex	245	TCP/IP Interface Object <sup>1)</sup>	x		
F6 hex	246	Ethernet Link Object <sup>1)</sup>	x		

Object class		Object name	Objects required	ODVA objects	SINAMICS objects
hex	dec				
300 hex	768	Stack Diagnostic Object		x	x
302 hex	770	Adapter Diagnostic Object		x	x
303 hex	771	Explicit Messages Diagnostic Object		x	x
304 hex	772	Explicit Message Diagnostic List Object		x	x
401 hex	1025	Parameter object		x	x

1) These objects are part of the EtherNet/IP system management.

## Identity Object, Instance Number: 1 hex

### Supported services

- |       |   |          |  |
|-------|---|----------|--|
| Class | <ul style="list-style-type: none"> <li>• Get Attribute all</li> <li>• Get Attribute single</li> </ul> | Instance | <ul style="list-style-type: none"> <li>• Get Attribute all</li> <li>• Get Attribute single</li> <li>• Reset</li> </ul> |
|-------|---|----------|--|

Table 6-19 Class Attribute

No.	Service	Type	Name
1	get	UINT16	Revision
2	get	UINT16	Max Instance
3	get	UINT16	Num of Instances

Table 6-20 Instance Attribute

No.	Service	Type	Name	Value/explanation
1	get	UINT16	Vendor ID	1251
2	get	UINT16	Device Type - ODVA AC Drive - Siemens Drive	02 hex 12 hex
3	get	UINT16	Product code	r0964[1]
4	get	UINT16	Revision	The versions should match the EDS file
5	get	UINT16	Status	See the following table
6	get	UINT32	Serial number	bits 0 ... 19: consecutive number; bits 20 ... 23: Production identifier bits 24 ... 27: Month of manufacture (0 = Jan, B = Dec) Bits 28 ... 31: Year of manufacture (0 = 2002)
7	get	Short String	Product name	max. length 32 bytes e.g. SINAMICS G120





**Connection Management Object, Instance Number: 6 hex****Supported services**

- |       |   |          |   |
|-------|---|----------|---|
| Class | <ul style="list-style-type: none"> <li>• Get Attribute all</li> <li>• Get Attribute single</li> </ul> | Instance | <ul style="list-style-type: none"> <li>• Forward open</li> <li>• Forward close</li> <li>• Get Attribute single</li> <li>• Set Attribute single</li> </ul> |
|-------|---|----------|---|

Table 6-24 Class Attribute

No.	Service	Type	Name
1	get	UINT16	Revision
2	get	UINT16	Max Instance
3	get	UINT16	Num of Instances

Table 6-25 Instance Attribute

No.	Service	Type	Name	Value/explanation
1	get	UINT16	OpenReqs	Counters
2	get	UINT16	OpenFormat Re-jects	Counters
3	get	UINT16	OpenResource Rejects	Counters
4	get	UINT16	OpenOther Re-jects	Counters
5	get	UINT16	CloseReqs	Counters
6	get	UINT16	CloseFormat Re-jects	Counters
7	get	UINT16	CloseOther Re-jects	Counters
8	get	UINT16	ConnTimeouts	Counters Number of bus errors

**Motor Data Object, Instance Number 28 hex****Supported services**

- |       |  |          |  |
|-------|--|----------|--|
| Class | <ul style="list-style-type: none"> <li>• Get Attribute single</li> </ul> | Instance | <ul style="list-style-type: none"> <li>• Get Attribute single</li> <li>• Set Attribute single</li> </ul> |
|-------|--|----------|--|

Table 6-26 Class Attribute

No.	Service	Type	Name
1	get	UINT16	Revision
2	get	UINT16	Max Instance
3	get	UINT16	Num of Instances

Table 6-27 Instance Attribute

No.	Service	Type	Name	Value/explanation
3	get, set	USINT	Motor Type	p0300 motor type, see the following table
6	get, set	UINT16	Rated Current	p0305 rated motor current
7	get, set	UINT16	Rated Voltage	p0304 rated motor voltage
8	get, set	UINT32	Rated Power	p0307 rated motor power
9	get, set	UINT16	Rated Frequency	p0310 rated motor frequency
10	get, set	UINT16	Rated Temperature	p0605 motor temperature threshold
11	get, set	UINT16	Max Speed	p0322 maximum motor speed
12	get, set	UINT16	Pole Count	p0314 value of p0314*2
13	get, set	UINT32	Torque Constant	p0316 motor torque constant
14	get, set	UINT32	Inertia	p0341 motor moment of inertia
15	get, set	UINT16	Base Speed	p0311 motor rated speed

Value in p0300		Ethernet/IP motor data object,	
0	No motor	0	Non-standard motor
1	induction motor	7	squirrel cage induction motor
2	synchronous motor	3	PM synchronous motor
10	1LE1 induction motor	7	squirrel cage induction motor
13	1LG6 induction motor	7	squirrel cage induction motor
17	1LA7 induction motor	7	squirrel cage induction motor
19	1LA9 induction motor	7	squirrel cage induction motor
100	1LE1 induction motor	7	squirrel cage induction motor
104	1PH4 induction motor	3	PM synchronous motor
107	1PH7 induction motor	0	non-standard motor
108	1PH8 induction motor	5	switched reluctance motor
200	1PH8 synchronous motor	0	non-standard motor
204	1LE4 synchronous motor	3	PM synchronous motor
237	1FK7 synchronous motor	0	non-standard motor
10000	motor with DRIVE-CLiQ	0	non-standard motor
10001	motor with DRIVE-CLiQ 2. D	0	non-standard motor

## Supervisor Object, Instance Number: 29 hex

## Supported services

- |       |                        |          |                        |
|-------|------------------------|----------|------------------------|
| Class | • Get Attribute single | Instance | • Get Attribute single |
|       |                        |          | • Set Attribute single |

Table 6-28 Class Attribute

No.	Service	Type	Name
1	get	UINT16	Revision
2	get	UINT16	Max Instance
3	get	UINT16	Num of Instances

Table 6-29 Instance Attribute

No.	Service	Type	Name	Value/explanation
3	get, set	Bool	Run1	STW.0 operation, clockwise rotation
5	get, set	Bool	Net Control	Internal 0: Local 1: Network
6	get	UINT8	State	0: Vendor Specific 1: Startup 2: Not_Ready 3: Ready 4: Enabled 5: Stopping 6: Fault_Stop 7: Faulted
7	get	Bool	Running1	ZSW1:2 1: - (Enabled and Run1) or - (Stopping and Running1) or - (Fault_Stop and Running1) 0 = Other state
9	get	Bool	Ready	ZSW1:0 1: - Ready or - Enabled or - Stopping 0 = Other state
10	get	Bool	Fault	ZSW1:3 drive fault
11	get	Bool	Warning	ZSW1:7 alarm active
12	get, set	Bool	Fault reset	STW.7 acknowledge fault
13	get	UINT16	Fault Code	r945[0] error code
14	get	UINT16	Warning Code	r2122[0] alarm code
15	get	Bool	CtlFromNet	Display from Net Control 1: Control from network 0: Local control

Drive Object, Instance Number: 2A hex

Supported services

- |       |  |          |  |
|-------|--|----------|--|
| Class | <ul style="list-style-type: none"> <li>• Get Attribute single</li> </ul> | Instance | <ul style="list-style-type: none"> <li>• Get Attribute single</li> <li>• Set Attribute single</li> </ul> |
|-------|--|----------|--|

Table 6-30 Class Attribute

No.	Service	Type	Name
1	get	UINT16	Revision
2	get	UINT16	Max Instance
3	get	UINT16	Num of Instances

Table 6-31 Instance Attribute

No.	Service	Type	Name	Value/explanation
3	get	Bool	At reference	r2197.4 1:  n_act  ≥ n_set 0: Otherwise
4	get, set	Bool	Net_reference	Internal 0: Local 1: Network
6	get	UINT8	Drive_Mode	p1300 manufacturer-specific, see following table
7	get	INT	Speed Actual	Main actual value, see speed units
8	get, set	INT	Speed Ref	Main setpoint, see speed units
9	get	INT	Current Actual	r0027 absolute current actual value, smoothed
10	get, set	INT	Current limit	p0323 maximum motor current
15	get	INT	Power Actual	r0032 actual active power smoothed
16	get	INT	Output voltage	r0025 output voltage smoothed
17	get	INT	Output voltage	r0072 output voltage
18	get, set	UINT16	AccelTime	p1120 ramp-function generator ramp-up time
19	get, set	UINT16	DecelTime	p1121 ramp-function generator, ramp-down time
20	get, set	UINT16	Low Speed Lim	p1080 minimum speed
21	get, set	UINT16	High Speed Lim	p1082 maximum speed
22	get, set	SINT	Speed Scale	p8982 Ethernet/IP ODVA speed scaling
29	get	Bool	Ref From Net	Internal - display of Net_Reference 0: Local 1: Network

Value in p1300		Ethernet/IP motor data object	
0	V/f with linear characteristic	1	Open loop speed (frequency)
1	V/f with linear characteristic and FCC	0	Vendor-specific mode
2	V/f with parabolic characteristic		
4	V/f with linear characteristic and ECO		
7	V/f for parabolic characteristic and ECO		
20	Speed control (without encoder)	2	Closed-loop speed control

## Siemens Drive Object, Instance Number: 32C hex

### Supported services

- |       |                        |          |                        |
|-------|------------------------|----------|------------------------|
| Class | • Get Attribute single | Instance | • Get Attribute single |
|       |                        |          | • Set Attribute single |

Table 6-32 Class Attribute

No.	Service	Type	Name
1	get	UINT16	Revision
2	get	UINT16	Max Instance
3	get	UINT16	Num of Instances

Table 6-33 Instance Attribute

No.	Type	Service	Name	Value/explanation
2	INT16	get, set	Commissioning state	p0010 commissioning parameter filter
3 ... 18	WORD	get	STW1	STW1 bit-by-bit access: Attr.3 = STW1.0 Attr.18 = STW1.15
19	WORD	get	Main setpoint	Main setpoint
20 ... 35	WORD	get	ZSW1	ZSW1 bit-by-bit access: Attr.20 = ZSW1.0 Attr.35 = ZSW1.15
36	WORD	get	Actual Frequency	Main actual value (actual frequency)
37	REAL	get, set	Ramp Up Time	p1120[0] ramp-function generator ramp-up time
38	REAL	get, set	Ramp Down Time	p1121[0] ramp-function generator ramp-down time
39	REAL	get, set	Current Limit	p0640[0] current limit
40	REAL	get, set	Frequency MAX Limit	p1082[0] maximum speed
41	REAL	get, set	Frequency MIN Limit	p1080[0] minimum speed
42	REAL	get, set	OFF3 Ramp Down Time	p1135[0] OFF3 ramp-down time
43	UINT32 / BOOL	get, set	PID Enable	p2200[0] technology controller enable

No.	Type	Service	Name	Value/explanation
44	REAL	get, set	PID Filter Time Constant	p2265 technology controller actual value filter time constant
45	REAL	get, set	PID D Gain	p2274 technology controller differentiation time constant
46	REAL	get, set	PID P Gain	p2280 technology controller proportional gain
47	REAL	get, set	PID I Gain	p2285 technology controller integral time
48	REAL	get, set	PID Up Limit	p2291 technology controller maximum limiting
49	REAL	get, set	PID Down Limit	p2292 technology controller minimum limiting
50	REAL	get	Speed setpoint	r0020 speed setpoint
51	REAL	get	Output Frequency	r0024 output frequency
52	REAL	get	Output Voltage	r0025 output voltage
53	REAL	get	DC Link Voltage	r0026[0] DC link voltage
54	REAL	get	Actual Current	r0027 current actual value
55	REAL	get	Actual Torque	r0031 torque actual value
56	REAL	get	Output power	r0032 actual active power value
57	REAL	get	Motor Temperature	r0035[0] motor temperature
58	REAL	get	Power Unit Temperature	r0037[0] power unit temperature
59	REAL	get	Energy kWh	r0039 energy display
60	UINT8	get	CDS Eff (Local Mode)	r0050 active command data set
61	WORD	get	Status Word 2	r0053 status word 2
62	WORD	get	Control Word 1	r0054 control word 1
63	REAL	get	Motor Speed (Encoder)	r0061 speed actual value
64	UINT32	get	Digital Inputs	r0722 digital inputs status
65	UINT32	get	Digital Outputs	r0747 digital outputs status
66	REAL	get	Analog Input 1	r0752[0] analog input 1
67	REAL	get	Analog Input 2	r0752[1] analog input 2
68	REAL	get	Analog Output 1	r0774[0] analog output 1
69	REAL	get	Analog Output 2	r0774[1] analog output 2
70	UINT16	get	Fault Code 1	r0947[0] fault number 1
71	UINT16	get	Fault Code 2	r0947[1] fault number 2
72	UINT16	get	Fault Code 3	r0947[2] fault number 3
73	UINT16	get	Fault Code 4	r0947[3] fault number 4
74	UINT16	get	Fault Code 5	r0947[4] fault number 5
75	UINT16	get	Fault Code 6	r0947[5] fault number 6
76	UINT16	get	Fault Code 7	r0947[6] fault number 7
77	UINT16	get	Fault Code 8	r0947[7] fault number 8
78	REAL	get	Pulse Frequency	r1801 pulse frequency
79	UINT16	get	Alarm Code 1	r2110[0] alarm number 1
80	UINT16	get	Alarm Code 2	r2110[1] alarm number 2

No.	Type	Service	Name	Value/explanation
81	UINT16	get	Alarm Code 3	r2110[2] alarm number 3
82	UINT16	get	Alarm Code 4	r2110[3] alarm number 4
83	REAL	get	PID setpoint Output	r2260 technology controller setpoint after the ramp-function generator
84	REAL	get	PID Feedback	r2266 technology controller actual value after the filter
85	REAL	get	PID Output	r2294 technology controller output signal

### Siemens Motor Data Object, Instance Number: 32D hex

#### Supported services

- Class
- Get Attribute single
- Instance
- Get Attribute single
  - Set Attribute single

Table 6-34 Class Attribute

No.	Service	Type	Name
1	get	UINT16	Revision
2	get	UINT16	Max Instance
3	get	UINT16	Num of Instances

Table 6-35 Instance Attribute

No.	Service	Type	Name	Value/explanation
2	get, set	UINT16	Commissioning state	p0010
3	get	INT16	Motor Type	p0300
6	get, set	REAL	Rated Current	p0305
7	get, set	REAL	Rated Voltage	p0304
8	get, set	REAL	Rated Power	p0307
9	get, set	REAL	Rated Frequency	p0310
10	get, set	REAL	Rated Temperature	p0605
11	get, set	REAL	Max Speed	p0322
12	get, set	UINT16	Pole pair number	p0314
13	get, set	REAL	Torque Constant	p0316
14	get, set	REAL	Inertia	p0341
15	get, set	REAL	Base Speed	p0311
19	get, set	REAL	Cos Phi	p0308

TCP/IP Interface Object, Instance Number: F5 hex

Supported services

- |       |   |          |   |
|-------|---|----------|---|
| Class | <ul style="list-style-type: none"> <li>• Get Attribute all</li> <li>• Get Attribute single</li> </ul> | Instance | <ul style="list-style-type: none"> <li>• Get Attribute all</li> <li>• Get Attribute single</li> <li>• Set Attribute single</li> </ul> |
|-------|---|----------|---|

Table 6-36 Class Attribute

No.	Service	Type	Name
1	get	UINT16	Revision
2	get	UINT16	Max Instance
3	get	UINT16	Num of Instances

Table 6-37 Instance Attribute

No.	Service	Type	Name	Value/explanation
1	get	UNIT32	Status	Fixed value: 1 hex 1: Configuration acknowledged, by DHCP or saved values
2	get	UNIT32	Configuration Capability	Fixed value: 94 hex 4 hex: DHCP supported, 10 hex: Configuration can be adjusted, 80 hex: ACD-capable
3	get, set	UNIT32	Configuration Control	1 hex: Saved values 3 hex: DHCP
4	get	UNIT16	Path Size (in WORDs)	Fixed value: 2 hex
		UNIT8	Path	20 hex, F6 hex, 24 hex, 05 hex, where 5 hex is the number of instances of F6 hex (four physical ports plus one internal port).
5	get, set	STRING	Interface Configuration	r61000 Name of Station
		UNIT32		r61001 IP address
6	get, set	UNIT16	Host Name	Host Name Length
		STRING		
10	get, set	UNIT8	Select ACD	local OM flash: 0: Disabled, 1: Enabled
11	get, set	UNIT8	Last Conflict Detected	local OM flash ACD Activity
		UNIT8		local OM flash Remote MAC
		UNIT8		local OM flash ARP PDU



## Link Object, Instance Number: F6 hex

## Supported services

Class	<ul style="list-style-type: none"> <li>• Get Attribute all</li> <li>• Get Attribute single</li> </ul>	Instance	<ul style="list-style-type: none"> <li>• Get Attribute all</li> <li>• Get Attribute single</li> <li>• Set Attribute single</li> </ul>
-------	---	----------	---

Table 6-38 Class Attribute

No.	Service	Type	Name
1	get	UINT16	Revision
2	get	UINT16	Max Instance
3	get	UINT16	Num of Instances

Table 6-39 Instance Attribute

No.	Service	Type	Name	Value/explanation
1	get	UINT32	Interface Speed	0: link down, 10: 10 Mbps, 100: 100 Mbps
2	get		Interface Flags	Bit 1: Link-Status Bit 2: Duplex Mode (0: half duplex, 1 duplex) Bit 3 ... 5: Automatic state identification Bit 6: Reset required Bit 7: Local hardware fault (0 = ok)
3	get	ARRAY	Physical Address	r8935 Ethernet MAC address
4	get_and_clear	Struct of	Interface Counters	Optional, required if the "Media Counters Attribute" is implemented.
		UINT32	In Octets	Received octets
		UINT32	In Ucast Packets	Received Unicast packets
		UINT32	In NUcast Packets	Received non-Unicast packets
		UINT32	In Discards	Incoming packets, not processed
		UINT32	In Errors	Incoming packets with errors
		UINT32	In Unknown Protocols	Incoming packets with unknown protocol
		UINT32	Out Octets	Sent octets
		UINT32	Out Ucast Packets	Sent Unicast packets
		UINT32	Out NUcast packets	Sent non-Unicast packets
		UINT32	Out Discards	Outgoing packets, not processed
UINT32	Out Errors	Outgoing packets, with errors		



**Example: Read parameter 2050[10] (connector output to interconnect the PZD received from the fieldbus controller)**

Get Attribute single function with the following values:

- Class = 401 hex
- Instance = 2050 = 802 hex  $\hat{=}$  parameter number
- Attribute = 10 = A hex  $\hat{=}$  Index 10

**Example: Parameter 1520[0] writing (upper torque limit)**

Set Attribute single function with the following values:

- Class = 401 hex
- Instance = 1520 = 5F0 hex  $\hat{=}$  parameter number
- Attribute = 0 = 0 hex  $\hat{=}$  index 0
- Data = 500.0 (value)

## Supported ODVA AC/DC assemblies

### Overview

Number		required/ optional	Type	Name
hex	dec			
14 hex	20	Required	Sending	Basic Speed Control Output
46 hex	70	Required	Receiving	Basic Speed Control Input

### Assembly Basic Speed Control, Instance Number: 20, type: Output

Byte	Bit 7	Bit 6	Bit 5	Bit 4	Bit 3	Bit 2	Bit 1	Bit 0
0						Fault Reset		RUN Forward
1								
2	Speed Reference (Low Byte)							
3	Speed Reference (High Byte)							

### Assembly Basic Speed Control, Instance Number: 70, type: Input

Byte	Bit 7	Bit 6	Bit 5	Bit 4	Bit 3	Bit 2	Bit 1	Bit 0
0						Running Forward		Faulted
1								
2	Speed Actual (Low Byte)							
3	Speed Actual (High Byte)							

### 6.2.4.5 Create generic I/O module

For certain controllers, or if you wish to use the SINAMICS profile, you cannot use the EDS file provided by Siemens. In these cases, you must create a generic I/O module in the control system for the cyclic communication.

#### Procedure

1. In your control, create a generic device with Ethernet/IP functionality.
2. Enter the lengths for the process data for cyclic communication which you selected in Startdrive, r2067 [0] (input), r2067 [1] (output) into the new device, for example: Standard telegram 2/2 .  
4 ms is supported as the minimum value for RPI (Requested Packet Interval).
3. In Startdrive, set the same values for IP address, subnet mask, default gateway and name of the station as in the control system.



Configuring communication via EtherNet/IP (Page 195).

You have created a generic I/O module for cyclic communication with the converter.

You can find a detailed description of how to create a generic I/O module at the following link:  
 <http://support.automation.siemens.com/WW/view/en/82843076>

### 6.2.4.6 The converter as Ethernet node

#### Integrating a converter into an Ethernet network (assigning an IP address)

#### Procedure

1. Set p8924 (PN DHCP mode) = 2 or 3
  - p8924 = 2: The DHCP server assigns the IP address based on the MAC address of the converter.
  - p8924 = 3: The DHCP server assigns the IP address based on the device name of the converter.
2. Save the settings with p8925 = 2. The next time that the converter switches on, it retrieves the IP address, and you can address the converter as Ethernet node.

---

#### Note

##### Immediate switchover without restart

The switchover to DHCP is performed immediately and without a restart if the change is carried out with the EtherNet/IP command "Set Attribute Single" (class F5 hex, attribute 3). The following options are available:

- via an EtherNet/IP controller
  - via an EtherNet/IP commissioning tool
- 

You have now integrated the converter into Ethernet

#### Displays

r8930: Device name of the converter

r8934: Operating mode, PN or DHCP

r8935: MAC address

### Additional information

You can find information about parameters and messages (A08565) in the parameter list.

 Parameters (Page 373)

## Additional options of integrating converters into Ethernet

You also have the option of integrating the converter into Ethernet using Proneta or STEP 7, for example.

Here is the example of the "Edit Ethernet station" screen form from Step 7, which you can use to make the required settings.

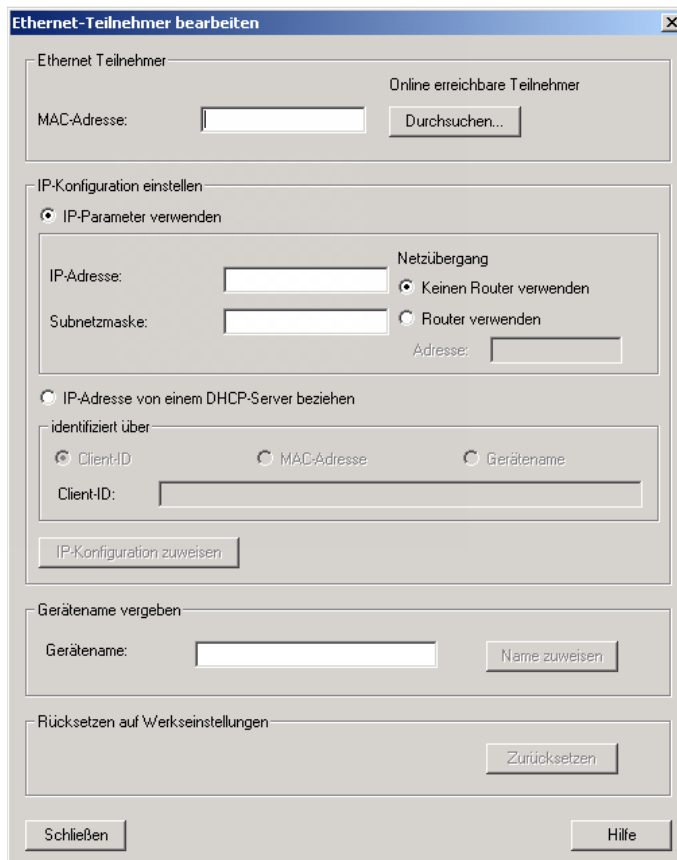

### 6.2.5 Jogging

#### Overview



The "Jog" function is typically used to temporarily move a motor using local control commands.

#### Function description

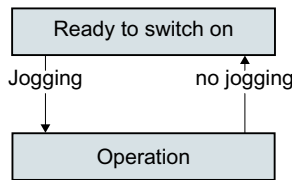

Commands "Jog 1" or "Jog 2" switch the motor on and off.

The commands are only active when the converter is in the "Ready for switching on" state.

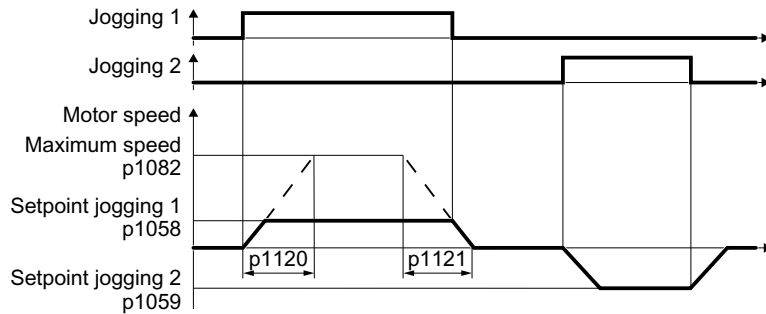

Figure 6-17 Behavior of the motor when "jogging"

After switching on, the motor accelerates to the setpoint, jog 1 or setpoint, jog 2. The two different setpoints can, for example, be assigned to motor clockwise and counter-clockwise rotation.

When jogging, the same ramp-function generator is active as for the ON/OFF1 command.

#### Example

Parameter	Description
p1055 = 722.0	<b>Jogging bit 0:</b> Select jogging 1 via digital input 0
p1056 = 722.1	<b>Jogging bit 1:</b> Select jogging 2 via digital input 1

#### Parameter

Number	Name	Factory setting
p1055[C]	BI: Jogging bit 0	0
p1056[C]	BI: Jogging bit 1	0

---

Number	Name	Factory setting
p1058[D]	Jogging 1 speed setpoint	150 rpm
p1059[D]	Jogging 2 speed setpoint	-150 rpm
p1082[D]	Maximum speed	1500 rpm
p1110[C]	BI: Inhibit negative direction	0
p1111[C]	BI: Inhibit positive direction	0
p1113[C]	BI: Setpoint inversion	0
p1120[D]	Ramp-function generator ramp-up time	10 s
p1121[D]	Ramp-function generator ramp-down time	10 s

## 6.2.6 Switching over the drive control (command data set)

### Overview



Several applications require the option of switching over the master control to operate the converter.

Example: The motor is to be operable either from a central control via the fieldbus or via the local digital inputs of the converter.

### Function description

#### Command data set (CDS)

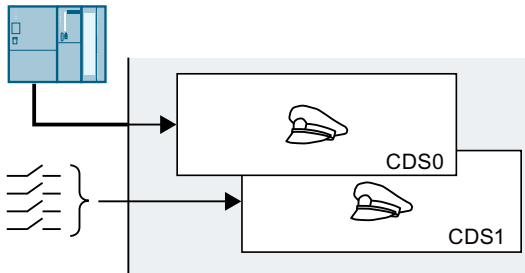

This means that you can set the converter control in various ways and toggle between the settings. For instance, as described above, the converter can either be operated via a fieldbus or via its digital inputs.

The settings in the converter, which are assigned to a specific master control, are called the command data set.

You select the command data set using parameter p0810. To do this, you must interconnect parameter p0810 with a control command of your choice, e.g. a digital input.

#### Changing the number of command data sets

1. Set p0010 = 15.
2. The number of command data sets is configured with p0170.
3. Set p0010 = 0.

You have changed the number of command data sets.



#### Copying command data sets

1. Set p0809[0] to the number of the command data set whose settings you wish to copy (source).
2. Set p0809[1] to the number of the command data set into which you wish to copy the settings.
3. Set p0809[2] = 1
4. The converter sets p0809[2] = 0.

You have copied the settings of a command data set into another command data set.





## Example

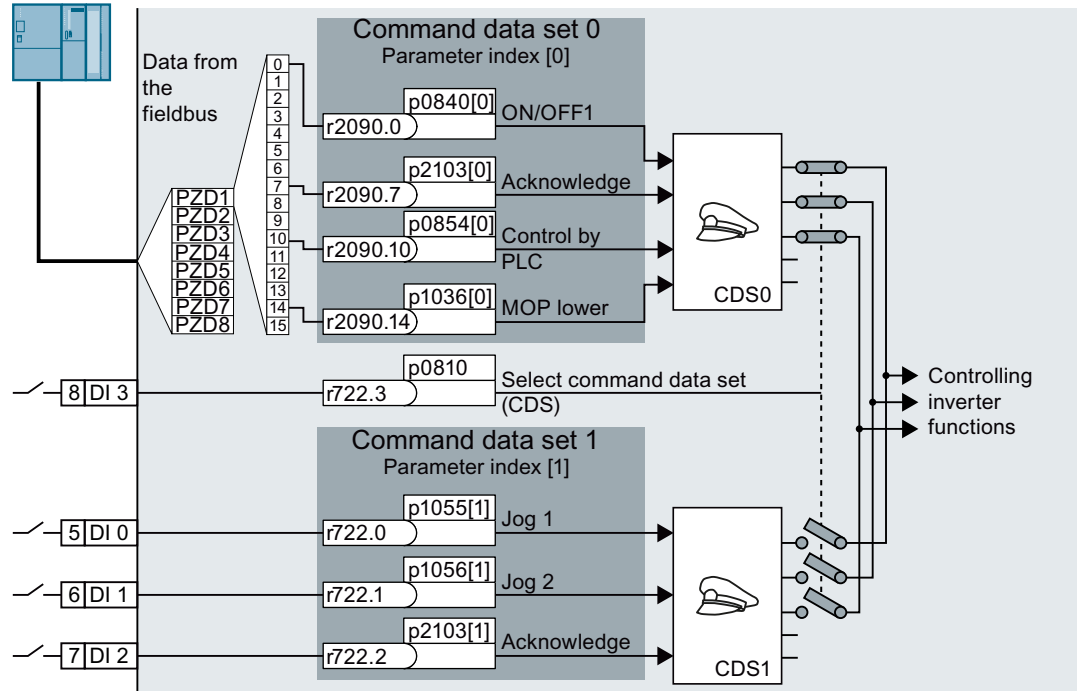

The converter evaluates its control commands depending on digital input DI 3:

- Via a fieldbus from a central control system
- Via the converter digital inputs at the installation.

### Note

The converter requires approx. 4 ms to switch over the command data set.

## Parameters

Number	Name	Factory setting
p0010	Drive commissioning parameter filter	1
r0050	CO/BO: Command data set CDS effective	-
p0170	Number of command data sets (CDS)	2
p0809[0 ... 2]	Copy command data set CDS	0
p0810	BI: Command data set selection CDS bit 0	0
p0811	BI: Command data set selection CDS bit 1	0

## 6.2.7 Selecting physical units

### 6.2.7.1 Motor standard

#### Selection options and parameters involved



The converter represents the motor data corresponding to motor standard IEC or NEMA in different system units: SI units or US units.

Table 6-41 Parameters involved when selecting the motor standard

Parameter	Designation	Motor standard IEC/NEMA, p0100 =		
		0 <sup>1)</sup> IEC motor 50 Hz, SI units	1 NEMA motor 60 Hz, US units	2 NEMA motor 60 Hz, SI units
r0206	Power Module rated power	kW	hp	kW
p0307	Rated motor power	kW	hp	kW
p0316	Motor torque constant	Nm/A	lbf ft/A	Nm/A
r0333	Rated motor torque	Nm	lbf ft	Nm
p0341	Motor moment of inertia	kgm <sup>2</sup>	lb ft <sup>2</sup>	kgm <sup>2</sup>
p0344	Motor weight	kg	Lb	kg
r0394	Rated motor power	kW	hp	kW
r1493	Total moment of inertia, scaled	kgm <sup>2</sup>	lb ft <sup>2</sup>	kgm <sup>2</sup>

<sup>1)</sup> Factory setting

It is only possible to change the motor standard during quick commissioning.

### 6.2.7.2 Unit system

Some physical units depend on the system of units selected (SI or US), for example the power [kW or hp] or the torque [Nm or lbf ft]. You can select in which system of units the converter represents its physical values.

#### Options when selecting the system of units

The following options apply when selecting the system of units:

- p0505 = 1: System of units SI (factory setting)  
Torque [Nm], power [kW], temperature [°C or K]
- p0505 = 2: Referred system of units/SI  
Represented as [%]
- p0505 = 3: US system of units  
Torque [lbf ft], power [hp], temperature [°F]
- p0505 = 4: System of units, referred/US  
Represented as [%]

## Special features

The values for  $p0505 = 2$  and for  $p0505 = 4$  - represented in the converter - are identical. However, the reference to SI or US units is required for internal calculations and to output physical variables.

For variables, which cannot be represented as [%], then the following applies:  
 $p0505 = 1 \triangleq p0505 = 2$  and  $p0505 = 3 \triangleq p0505 = 4$ .

In the case of variables whose units are identical in the SI system and US system, and which can be displayed as a percentage, the following applies:  
 $p0505 = 1 \triangleq p0505 = 3$  and  $p0505 = 2 \triangleq p0505 = 4$ .

## Reference variables

There is a reference variable in the converter for most parameters with physical units. When the referred representation [%] is set, then the converter scales the physical variables based on the particular reference variable.

When the reference variable changes, then the significance of the scaled value also changes. Example:

- Reference speed = 1500 rpm → fixed speed = 80 %  $\triangleq$  1200 rpm
- Reference speed = 3000 rpm → fixed speed = 80 %  $\triangleq$  2400 rpm

For each parameter you can find the associated reference variable for scaling in the parameter list. Example: r0065 is scaled with reference variable p2000.

If scaling is not specified in the parameter list, then the converter always shows/displays the parameter unscaled.

## Groups of units

The parameters associated with the selection of a physical unit, belong to different groups of units.

For each parameter you can find the associated unit group for scaling in the parameter list. Example: r0333 belongs to unit group 7\_4.

An overview of the unit groups and the possible physical units can also be found in the parameter list.

### 6.2.7.3 Technological unit of the technology controller

#### Options when selecting the technological unit

p0595 defines in which technological unit the input and output variables of the technology controller are calculated, e.g. [bar], [m<sup>3</sup>/min] or [kg/h].

#### Reference variable

p0596 defines the reference variable of the technological unit for the technology controller.

**Unit group**

Parameters involved with p0595 belong to unit group 9\_1.

Additional information is provided in the parameter list.

 Parameters (Page 373)

**Special features**

You must optimize the technology controller after changing p0595 or p0596.

**Additional technology controllers**

You can set the technological unit for each additional technology controller.

	Technological unit	Reference variable for the technological unit	Unit group
Additional technology controller 0	p11026	p11027	9_2
Additional technology controller 1	p11126	p11127	9_3
Additional technology controller 2	p11226	p11227	9_4

Additional information is provided in the parameter list.

**6.2.8 Safe Torque Off (STO) safety function**

**6.2.8.1 Safe Torque Off (STO) safety function**

**Overview**

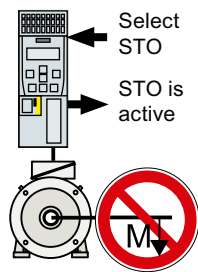

The converter with active STO function prevents energy supply to the motor. The motor can no longer generate torque on the motor shaft.

Consequently, the STO function prevents the starting of an electrically-driven machine component.

**The STO safety function conforms to IEC/EN 61800-5-2.**

The STO function is defined in IEC/EN 61800-5-2:

"[...] [The converter] does not supply the motor with power that can generate a torque (or for a linear motor, a force)".

**Precondition**

The machine manufacturer has already performed a risk assessment, e.g. in compliance with EN ISO 1050, "Safety of machinery - Principles of risk assessment".

**Function description**

	Safe Torque Off (STO)	Standard converter functions linked with STO
1.	The converter detects that STO has been selected via the failsafe digital input.	---
2.	The converter prevents the energy supply to the motor.	If you use a motor holding brake, the converter closes the motor holding brake. If you use a line contactor, the converter opens the line contactor.

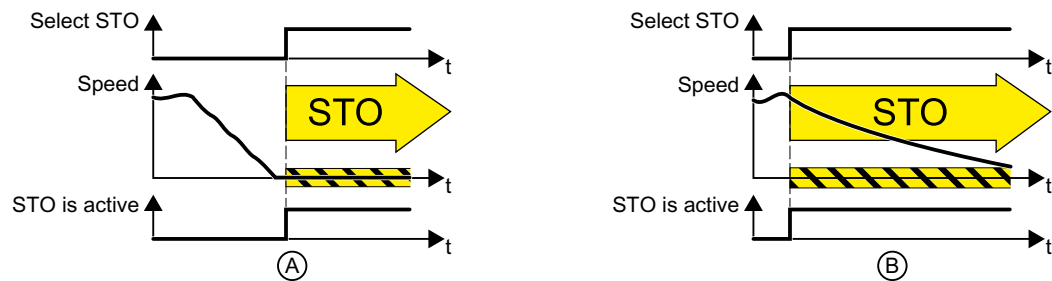

Figure 6-18 Functionality of STO when the motor is at standstill (A) and rotating (B)

(A): When selecting STO, if the motor is already stationary (zero speed), then STO prevents the motor from starting.

(B): If the motor is still rotating (B) when STO is selected, it coasts down to standstill.

**Example**

The STO function is suitable for applications where the motor is already at a standstill or will come to a standstill in a short, safe period of time through friction.

When STO is active, the converter can no longer electrically brake the motor, so that STO does not shorten the time that it takes for machine components to coast down to zero speed.

Application example	Possible solution
When the EMERGENCY STOP button is pressed, it is not permissible for a stationary motor to inadvertently accelerate.	<ul style="list-style-type: none"> <li>Connect the EMERGENCY STOP pushbutton with the failsafe converter digital input.</li> <li>Select STO via the failsafe digital input.</li> </ul>

More information

EN 60204-1 defines "EMERGENCY SWITCHING OFF" and "EMERGENCY STOP" as actions taken in an emergency. Further, it defines various stop categories for EMERGENCY STOP. "EMERGENCY SWITCHING OFF" and "EMERGENCY STOP" minimize different risks in the system or machine.

Table 6-42 The distinction between EMERGENCY OFF and EMERGENCY STOP

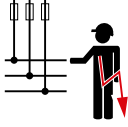
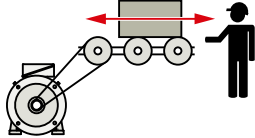
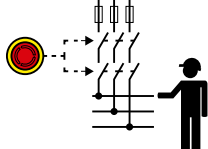
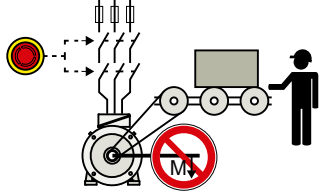
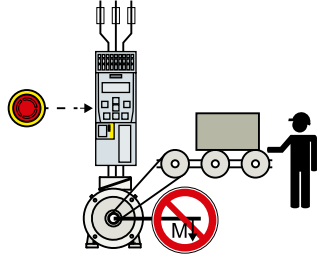
Action:	EMERGENCY SWITCHING OFF	EMERGENCY STOP Stop Category 0 according to EN 60204-1
Risk:	 <p>Electric shock</p>	 <p>Unexpected movement</p>
Measure to minimize risk:	<p><b>Switch off</b> Either completely or partially switch off hazardous voltages.</p>	<p><b>Prevent movement</b> Prevent hazardous movement.</p>
Classic solution:		 <p>Switch off the drive power supply</p>
Solution with the STO safety function integrated in the drive:	<p>Not possible. STO is not suitable for switching off a voltage.</p>	 <p>Select STO It is not necessary to switch off the voltage to minimize risk.</p>

6.2.8.2 Setting the feedback signal for Safe Torque Off

Overview

The converter signals that the STO safety function is controlled to the higher-level control system using two digital outputs.

## Function description

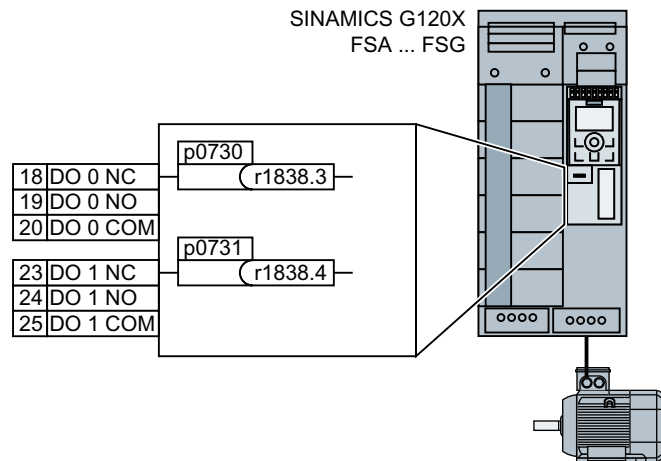

Figure 6-19 Feedback signal "STO is active" via digital outputs

For converters FSA...FSG, you must interconnect the feedback signals "STO is active" with two digital outputs.

### Procedure

1. Set p0730 = 1838.3
2. Set p0731 = 1838.4

You have interconnected the feedback signal for safety function STO with the digital outputs of the converter.

□

## Parameters

Number	Name	Factory setting
p0730	BI: CU signal source for terminal DO 0	52.3
p0731	BI: CU signal source for terminal DO 1	52.7
r1838	CO/BO: Gating unit status word 1 .03 1 signal: Shutdown path STO_B is inactive .04 1 signal: Shutdown path STO_A is inactive	---

Further information is provided in the parameter list.



Parameters (Page 373)

## 6.3 Pump control

### 6.3.1 Multi-pump control

#### Overview



Multi-pump control is suitable for applications that require simultaneous operation of up to four pumps, for example, equalizing significantly fluctuating water pressures or flow rates. After the function is enabled, you can configure the following four sub-functions based on your particular requirements:

- Pump switch-in/switch-out (Page 224)
- Stop mode (Page 229)
- Pump switchover (Page 232)
- Service mode (Page 234)

Multi-pump control provides a flexible and cost-effective solution for the following:

- Smoothly start and stop every pump to ensure the best performance of the water supply system
- Simplify the control system

---

#### Note

When using the multi-pump function, additional I/O module is needed to support more than two pumps.

---

#### Note

The multi-pump control function is not supported on G120X converter variants of power rating 30 kW or above.

---

#### Precondition

Before using the multi-pump control function, make sure that you have connected pumps of the same power rating.

#### Function description

The converter uses four relays (KP1 to KP4), which are connected to digital outputs DO 0 to DO 3, to switch pumps in and out according to the PID error (r2273). In addition, two groups of contactors, KDs and KMs, are designed to switch the pumps between converter operation and line operation. Soft pump switching can be realized as all motors start/stop with ramp speeds, so as to minimize the shock to the pipes.

Parameter p29520 is used to enable the multi-pump control.



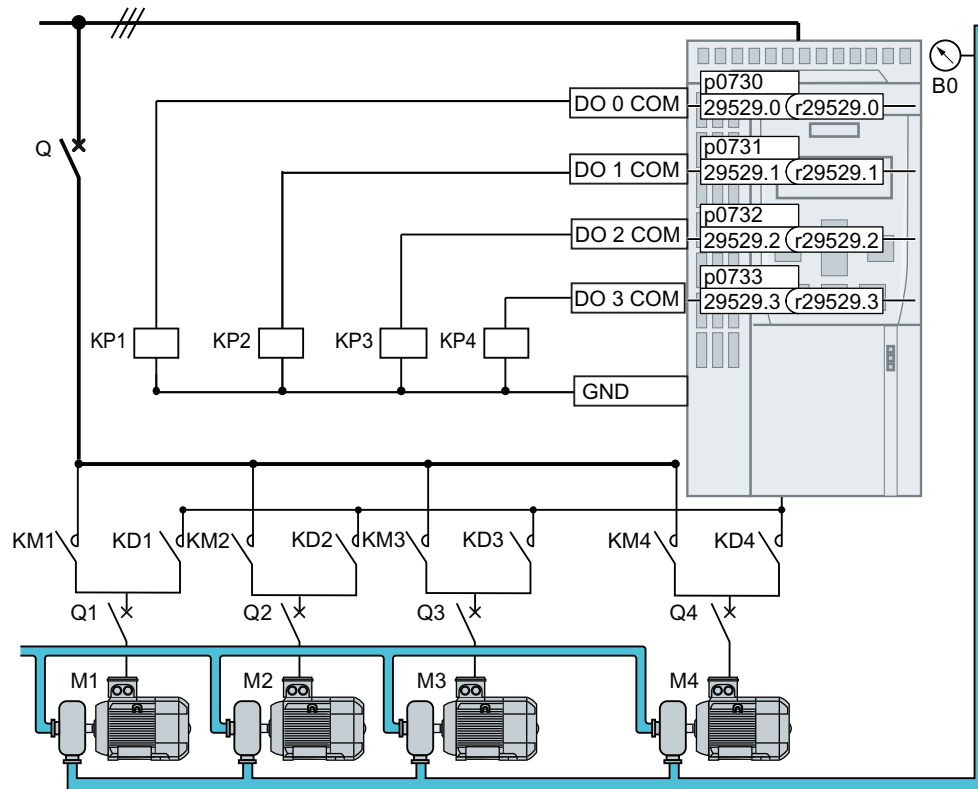

Q/Q1 ... Q4 Low-voltage circuit breakers

M1 ... M4 Motors

B<sub>0</sub> Pressure sensor. Interconnect the signal of the pressure sensor with the actual-value input of the technology controller.

Figure 6-20 Mains circuit

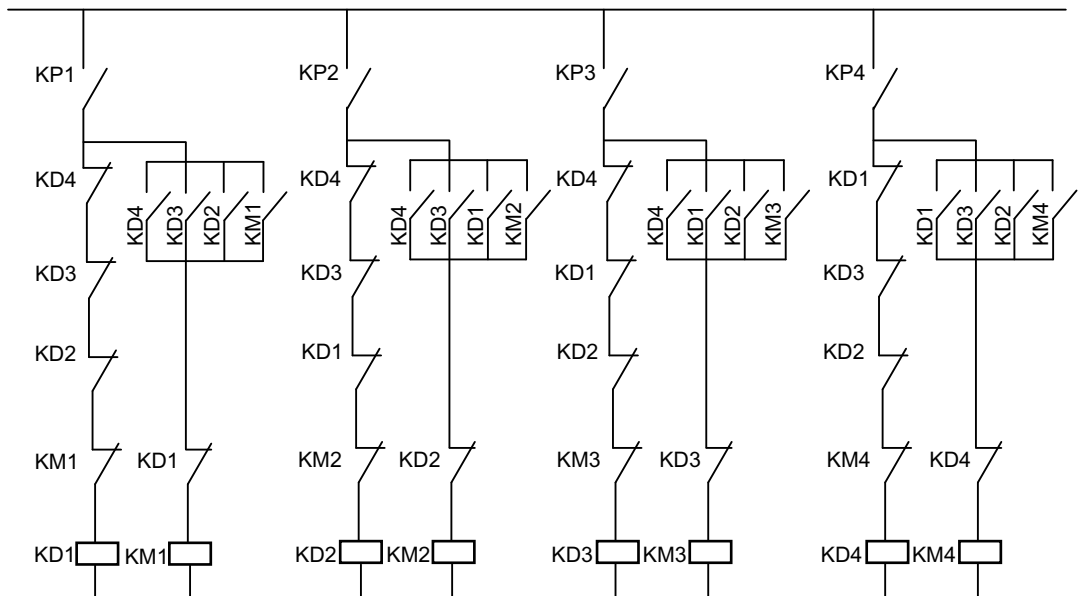

Figure 6-21 External relay control circuit

---

**Note**

When using the multi-pump control for the first time, make sure that the circuit breakers are disconnected until the relevant parameters are configured.

---

**Note**

When the multi-pump control is enabled (p29520=1), the values of p1274 and p1264 are set to 0 automatically and you can modify the values if required.

---

**Note**

**Motor current peaks when switching the motor from converter operation to line operation**

If the motor is switched from converter operation to the line supply, this can result in a high surge current  $> 10 \times I_{\text{rated}}$  in the motor, depending on the random phase shift between converter and line voltage.

---

## Further information

Interaction with other functions:

- When activating the essential service mode, if the multi-pump control is active, the motor connection status remains unchanged and the converter-controlled motor switches the speed setpoint to "ESM setpoint source".
- When activating the hibernation mode, if the multi-pump control is active, the hibernation mode only works when there is only one operating motor and the conditions for hibernation are satisfied.

### 6.3.1.1 Pump switch-in/switch-out

#### Pump switch-in

If the pump controlled by the converter runs at the maximum speed (p1082) and the PID error (r2273) exceeds the switch-in threshold (p29523) but is lower than the overcontrol threshold (p29526) for a specified time (p29524), the converter first switches the pump from converter operation to line operation, and then switches on an idle pump. This pump is softly started with a ramp-up speed and runs in converter operation mode.

---

**Note**

If the PID error rises above the overcontrol threshold (p29526), the converter skips the delay time (p29524) and performs the switch-in operation immediately.

---

Parameter p29522 is used to define the selection mode for switching in motors.

- p29522 = 0: Selecting the next pump according to the fixed sequence. The converter switches in the pump by following the sequence M1 → M2 → M3 → M4.
- p29522 = 1: Selecting the next pump according to the operating hours. The converter switches in the pump with the least absolute operating hours (p29530[0...3]).

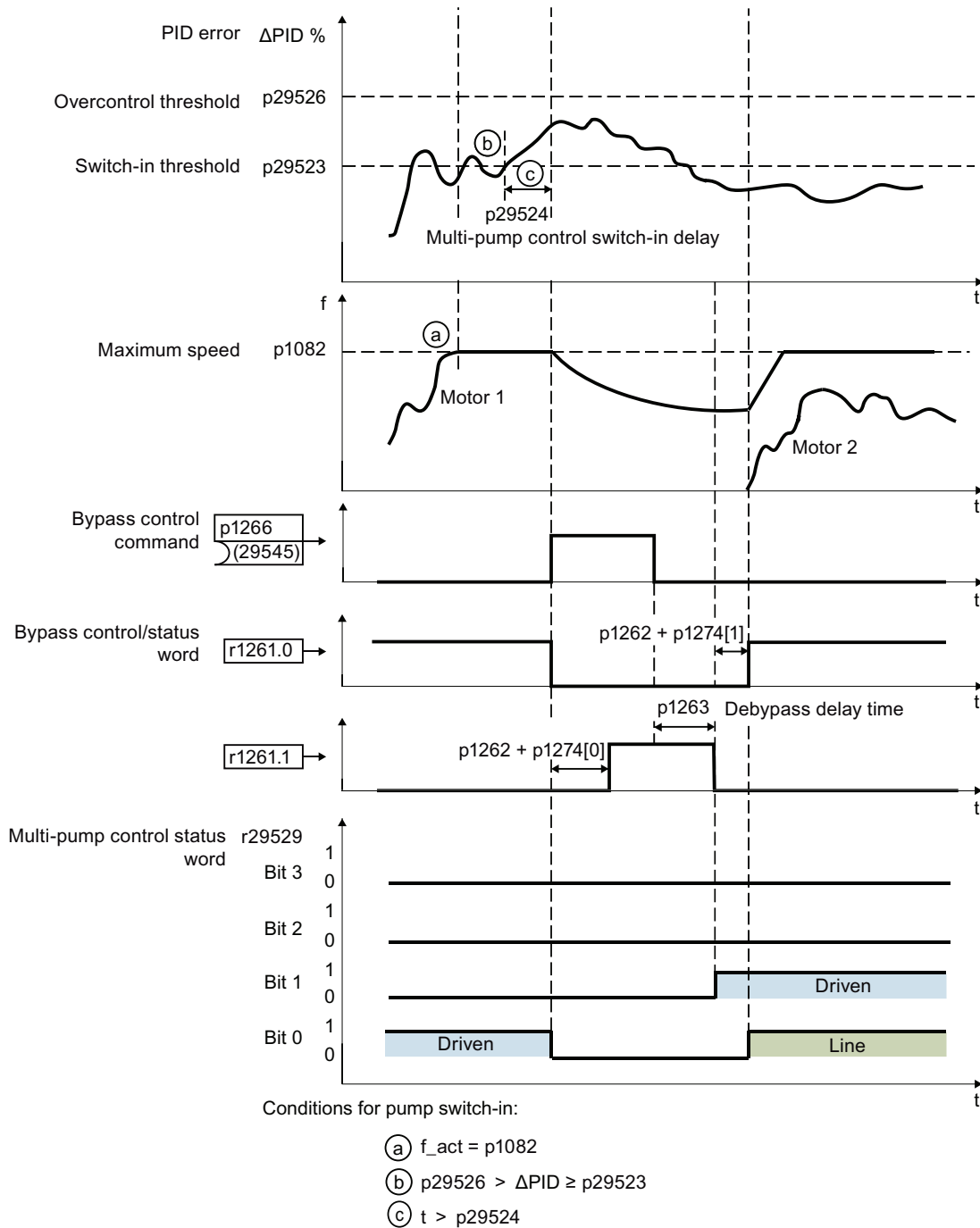

Figure 6-22 Pump switch-in

### Pump switch-out

If the pump controlled by the converter runs at a speed lower than the switch-out threshold ( $p29528 + p1080$ ) and the PID error is lower than the switch-out threshold ( $-p29523$ ) for a specified time ( $p29525$ ), the converter switches off a pump based on the selection mode.

---

#### Note

If the PID error drops below the overcontrol threshold ( $-p29526$ ), the converter skips the delay time ( $p29525$ ) and performs the switch-out operation immediately.

---

Parameter  $p29522$  is used to define the selection mode for switching out motors. Bits 00 to 03 of  $r29529$  indicate the motor which is stopped depending on  $p29522$ .

- $p29522 = 0$ : Selecting the next pump according to the fixed sequence. The converters first switches off a pump (OFF2) which runs in converter operation (following the sequence  $M4 \rightarrow M3 \rightarrow M2 \rightarrow M1$ ), and then captures a running pump and switches it from line operation to converter operation.
- $p29522 = 1$ : Selecting the next pump according to the operating hours. The converter first switches out the pump with the most absolute operating hours ( $p29530[0...3]$ ).
  - If the pump with the most absolute operating hours is controlled by the converter, the converter first switches off this pump, and then captures a running pump in line operation and switches it to converter operation.
  - If the pump with the most absolute operating hours is connected to the line supply, the converter directly switches off this pump.

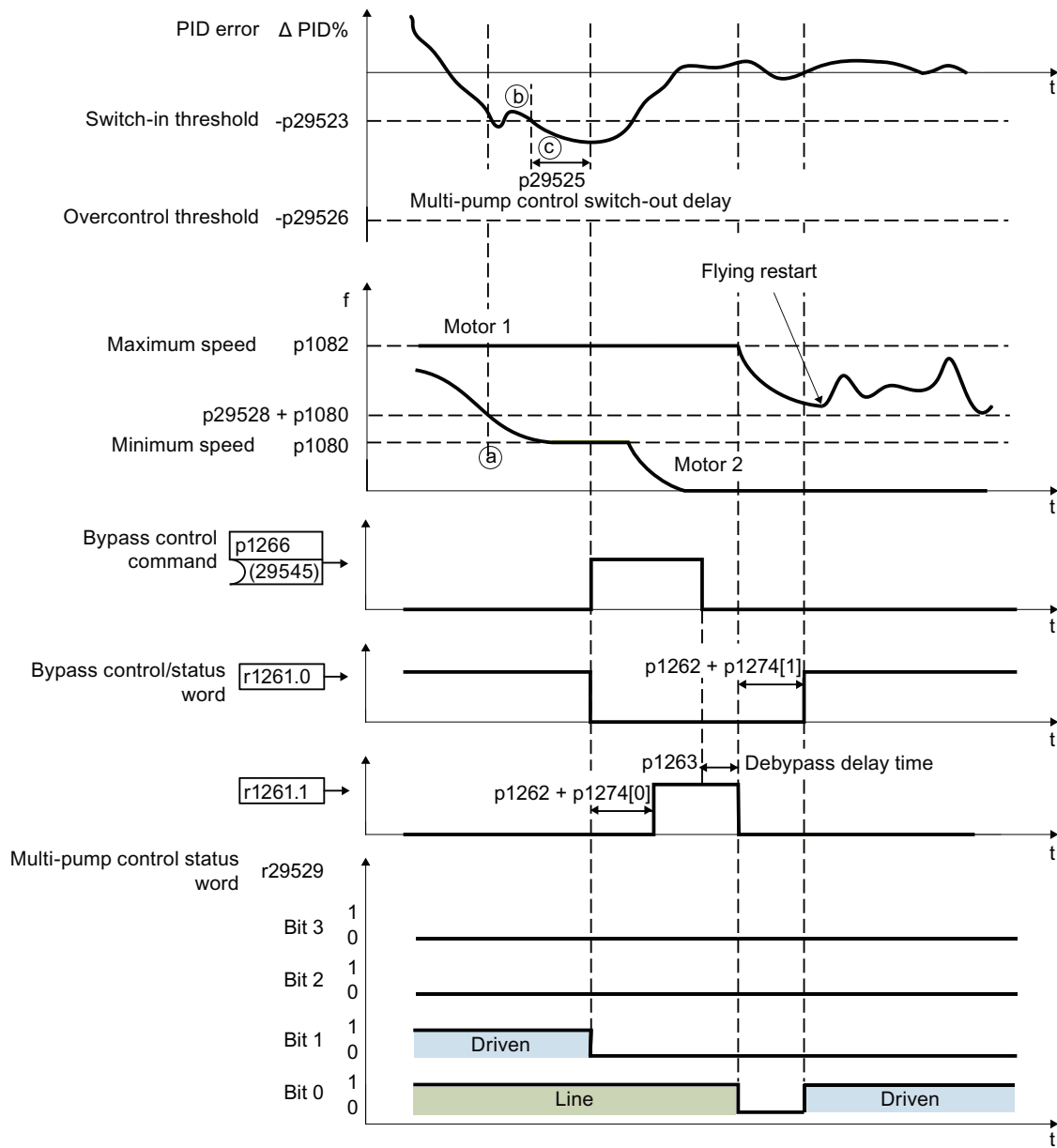

- Conditions for pump switch-out:
- (a)  $f_{act} < p29528 + p1080$
  - (b)  $-p29526 < \Delta \text{PID} \leq -p29523$
  - (c)  $t > p29525$

Figure 6-23 Pump switch-out based on the fixed sequence (p29522 = 0)

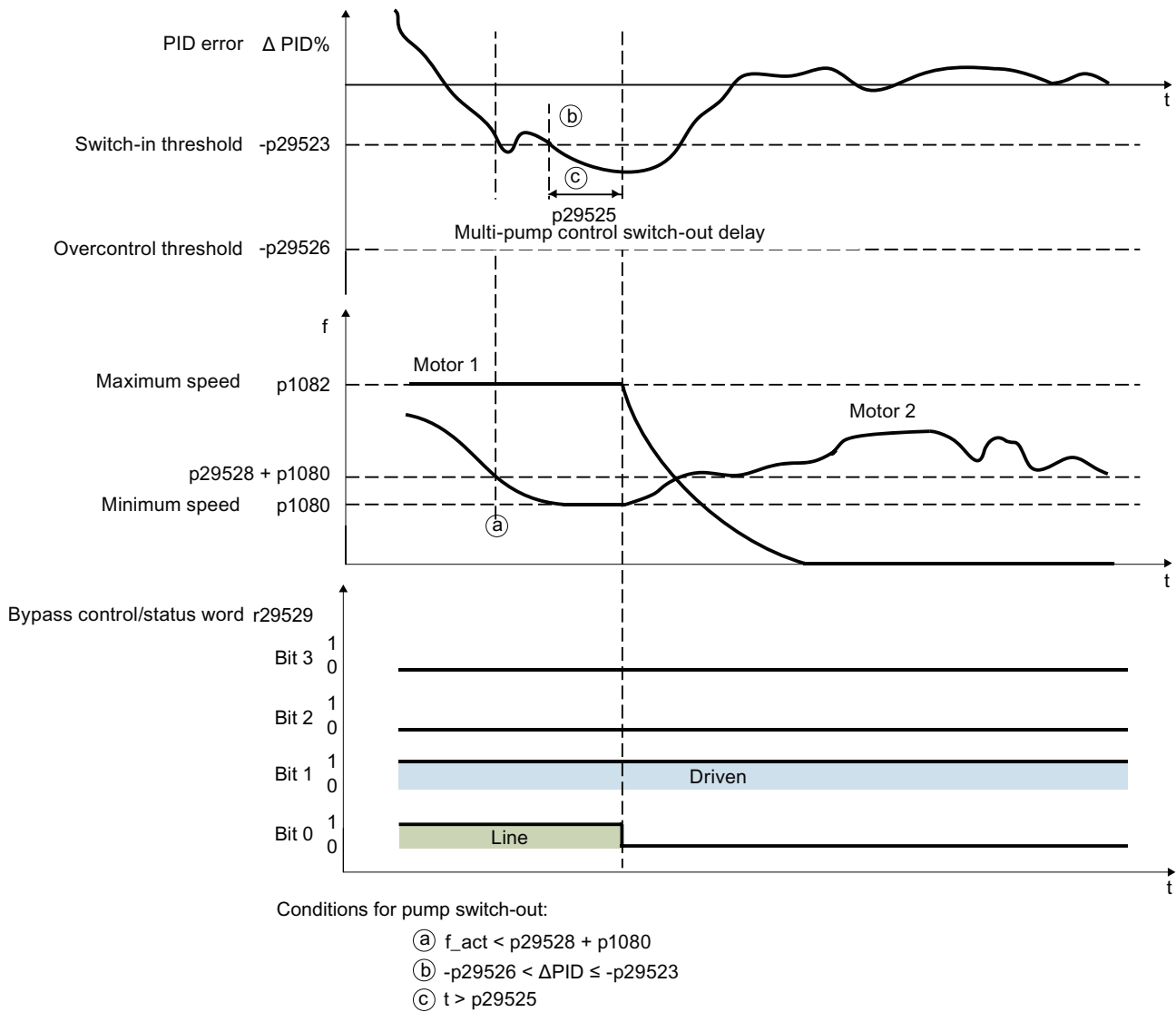

Figure 6-24 Pump switch-out based on the absolute operating hours (p29522 = 1)

**Note**

**Multi-pump control motor quantity not matched**

When you configure the multi-pump control function, make sure that the motor quantity set in p29521 matches with the quantity of digital outputs (mapped in r29529). Otherwise, there will be error A52966 and A07929.

**Note**

**Pump switch-in/switch-out interrupted when  $p29528 + p1080 = p1082$**

If  $p29528 + p1080 = p1082$ , there is possibility that the conditions for switch-in and switch-out will be met simultaneously. As a result, the system will not switch in or switch out pumps. To avoid such situation, do not set  $p29528 + p1080 = p1082$ .

## Parameters

Number	Name	Factory setting
p0730 ... p0733	BI: Signal source for digital outputs DO0 ... DO3	-
p1080[0...n]	Minimum speed	0 rpm
p1082[0...n]	Maximum speed	1500 rpm
p1262[0...n]	Bypass dead time	1 s
p1263	Debypass delay time	1 s
p1264	Bypass delay time	1 s
p1274[0...1]	Bypass switch monitoring time	1000 ms
p29520	Multi-pump control enable	0
p29521	Multi-pump control motor configuration	0
p29522	Multi-pump control motor selection mode	0
p29523	Multi-pump control switch-in threshold	20%
p29524	Multi-pump control switch-in delay	30 s
p29525	Multi-pump control switch-out delay	30 s
p29526	Multi-pump control overcontrol threshold	25%
p29527	Multi-pump control interlocking time	0 s
p29528	Multi-pump control switch-out speed offset	100 rpm
r29529	BO/CO: Multi-pump control status word	-
p29530[0...3]	Multi-pump control absolute operating hours	0 h
r29538	Multi-pump control variable-speed motor	-
p29546	Multi-pump control deviation threshold	20%



For more information about the parameters, see Chapter "Parameters (Page 373)".

### 6.3.1.2 Stop mode

#### Function description

Two stop modes are available as follows:

- Normal stop: All pumps running in line operation are switched off simultaneously as soon as the stop command is received. The pump in converter operation stops under the control of the converter. Normal stop aims to quickly stop all the pumps under emergency situations such as pipe cracks or leakages.
- Sequence stop: The pumps running in line operation stop one by one in the reverse sequence in which they are switched on. There is a delay time (p29537) between every pump stop. The pump in converter operation stops under the control of the converter after the first pump in line operation is switched off. Sequence stop aims to reduce the water hammer effect to pipes especially in systems with high power range.

After the OFF command is received, the pumps are switched off in either of the two stop modes:

- With OFF1 command received, the pump stop mode is selected in parameter p29533 as follows:
  - p29533 = 0: normal stop
  - p29533 = 1: sequence stop
- With OFF2/OFF3 command received, the pumps are switched off with normal stop.

---

**Note**

**Sequence stop**

During sequence stop, the motors are switched off in the reverse sequence in which they are switched on. It is therefore important that the motor configuration parameter p29521 is not changed while the converter is running. Otherwise, the parameter value may no longer correspond to the mapping of the motors connected.

---



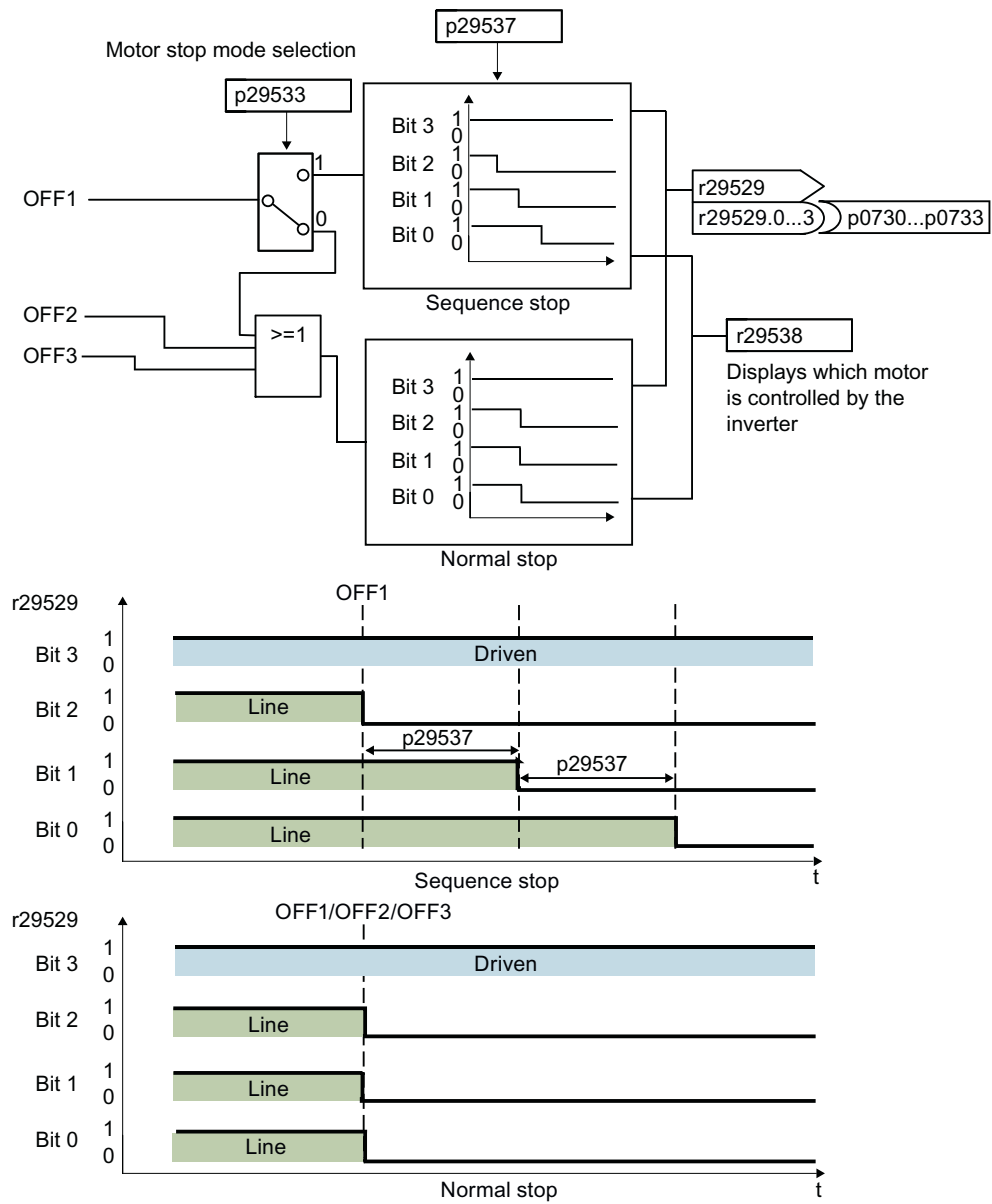

Figure 6-25 Stop mode

### Parameters

Number	Name	Factory setting
p29533	Multi-pump control switch-off sequence	0
p29537	Multi-pump control disconnection lockout time	0 s
r29538	Multi-pump control variable-speed motor	-

For more information about the parameters, see Chapter "Parameters (Page 373)".

### 6.3.1.3 Pump switchover

#### Function description

With pump switchover enabled (with p29539), the converter monitors the operation status of all running pumps.

- If the continuous operating hours (p29547) of the pump in converter operation exceed the threshold (p29531), the converter switches off the pump and then switches in an idle pump to keep constant output power.
- If the continuous operating hours (p29547) of a pump in line operation exceed the threshold (p29531), the converter first switches off the pump, switches out the converter-controlled pump to line operation, and then switches in an idle pump to run in converter operation to keep constant output power.

You can use parameter p29522 to define the selection mode for the next pump. The internal counters (p29530[0...3] and p29547[0...3]) are used to calculate the operating hours of the pumps.

- p29522 = 0: Selecting the next pump according to the fixed sequence.  
The converter first switches out the pump with the most continuous operating hours (p29547[0...3]) and then switches in a pump following the sequence of M1 → M2 → M3 → M4.
- p29522 = 1: Selecting the next pump according to the operating hours.  
The converter switches out the pump with the most continuous operating hours (p29547[0...3]) and then switches in the pump with the least absolute operating hours (p29530[0...3]).

When a pump is switched off, the continuous operating hours (p29547) of this pump reset to zero automatically.

This function balances the operation time of each pump, extends the lifetime expectancy of the system and reduces downtime.

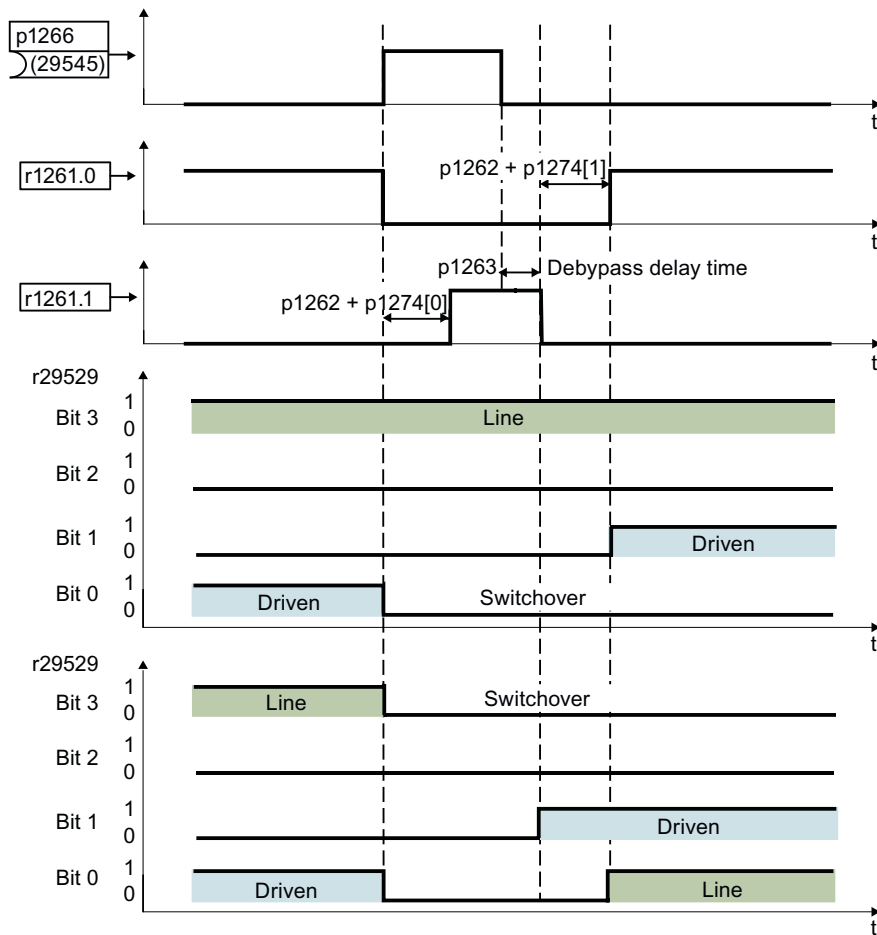
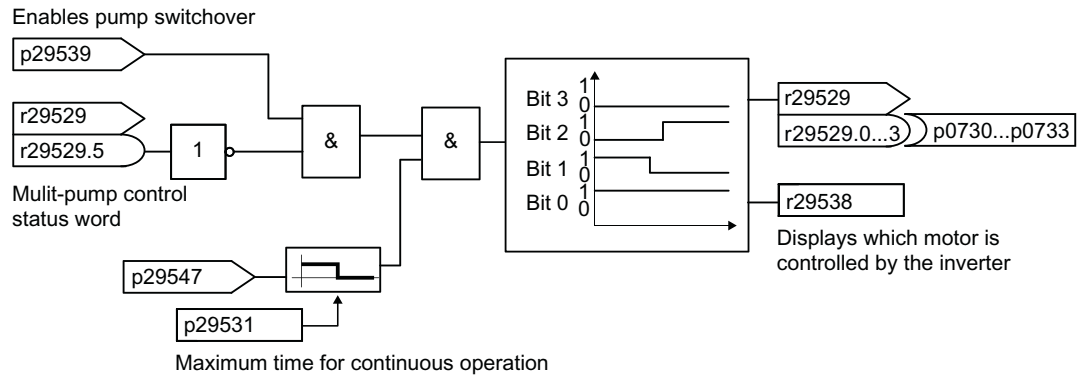

Figure 6-26 Pump switchover

**Note**

**Possible alarms and faults**

With pump switchover enabled, if the continuous operating hours (p29547) of the pump exceed the threshold (p29531) while the pump switchover is not possible (r29529.6 = 1), alarm A52962 appears. In this case, increase p29531 or reset p29547 to clear the alarm.

Parameters

Number	Name	Factory setting
p29522	Multi-pump control motor selection mode	0
r29529.6	CO/BO: Multi-pump control status word: pump switchover is not possible	-
p29530[0...3]	Multi-pump control motors absolute operating hours	-
p29531	Multi-pump control maximum time for continuous operation	24 h
p29539	Multi-pump control switchover enable	0
p29547[0...3]	Multi-pump control motors continuous operating hours	-
r29538	Multi-pump control variable-speed motor	-

 For more information about the parameters, see Chapter "Parameters (Page 373)".

6.3.1.4 Service mode

Function description

When a pump is in service mode, the converter locks the corresponding relay. Then you can perform troubleshooting of this pump without interrupting the operation of other pumps. You can use parameters p29540 to p29543 to set the pumps to work in service mode respectively. Pumps in service mode are skipped in further multi-pump control process.



**⚠ WARNING**

**Risk of electric shock due to incorrectly connected low-voltage circuit breakers**

If a low-voltage circuit breaker is not connected correctly to a pump set in service mode, hazardous voltages can be present at the pump when the converter relay malfunctions. Troubleshooting the service pump can result in serious personal injury or death.

- Make sure that all pumps are connected correctly to the mains and converter through low-voltage circuit breakers.
- After a pump is set in service mode, make sure that its low-voltage circuit breaker is open before performing any troubleshooting operation.

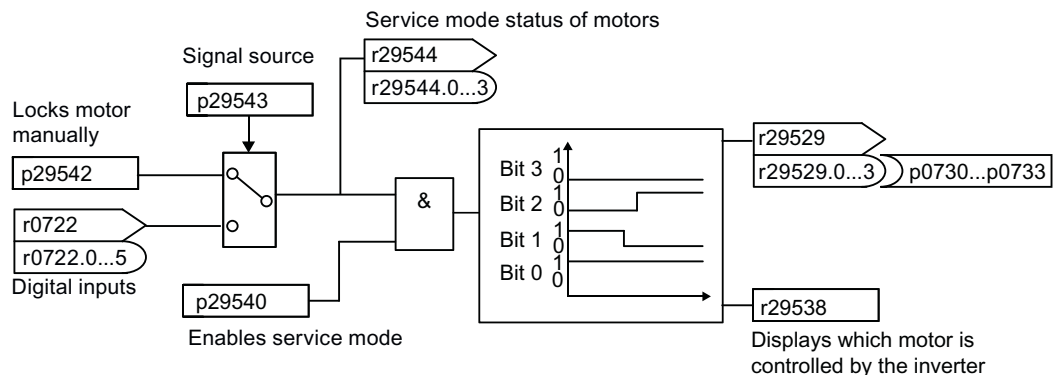

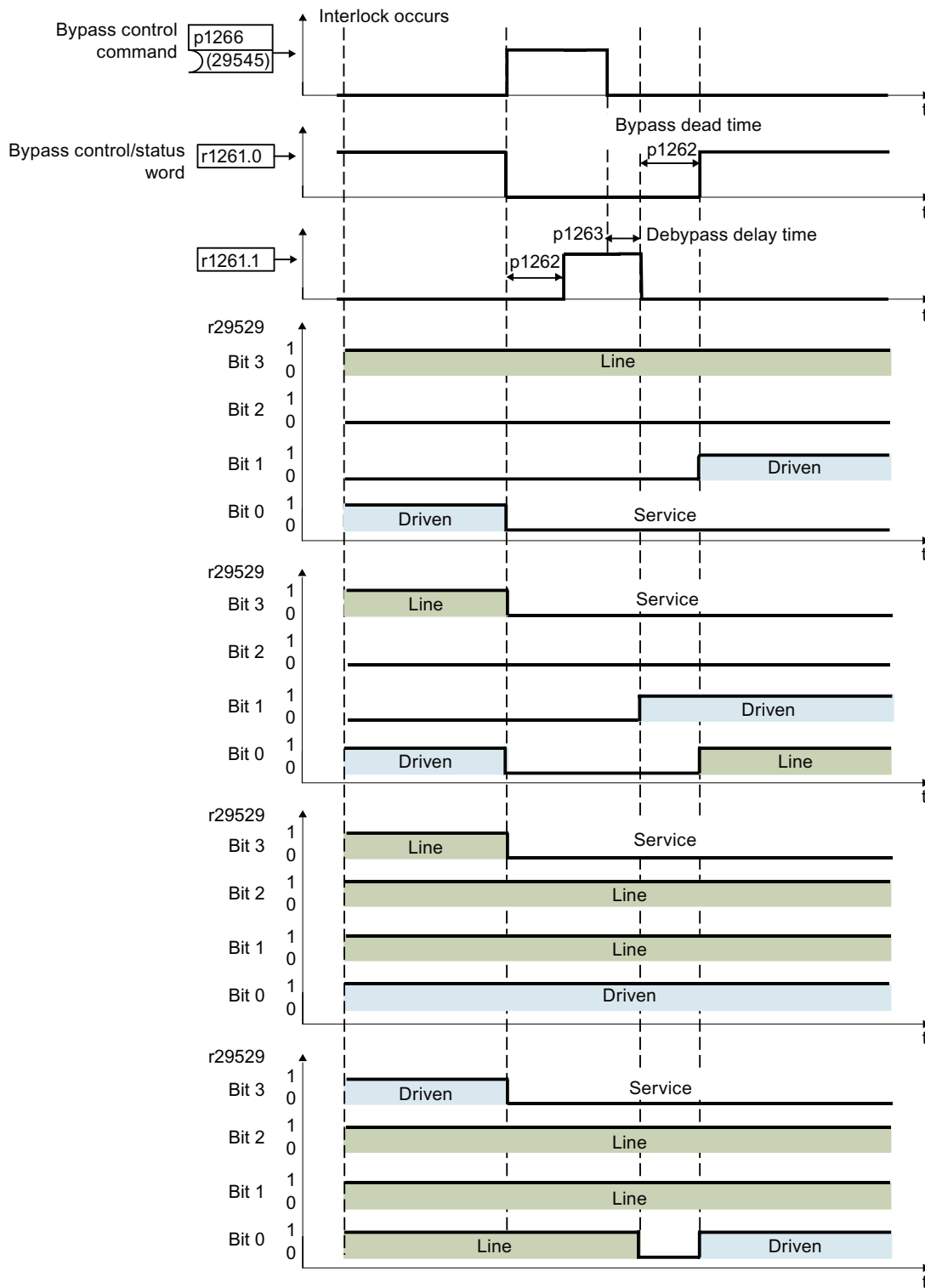

Figure 6-27 Service mode

**Note**

**Possible alarms and faults**

- If the PID deviation r2273 exceeds the threshold p29546 and no pump is available for switch-in, alarm A52963 appears.
- If there is only one pump that is not under service or locked manually, alarm A52964 appears.
- If all motors are under service or locked manually, fault F52965 appears.

For more information about the causes and remedies of the possible alarms and faults, see Section "Warnings, faults and system messages (Page 777)".

**Parameters**

Number	Name	Factory setting
p29540	Multi-pump control service mode enable	0
p29542	BO/CO: Multi-pump control service mode interlock manually	-
p29543[0...3]	BI: Multi-pump control motor under repair	[0] p29542.0 [1] p29542.1 [2] p29542.2 [3] p29542.3
r29544	Multi-pump control index of motors under repair	-

 For more information about the parameters, see Chapter "Parameters (Page 373)".

## 6.3.2 Frost protection

### Overview



The freezing water inside of the pump will damage the pump. With the frost protection enabled, if the surrounding temperature falls below a given threshold, the motor turns automatically to prevent freezing.

### Precondition

Before enabling the frost protection, make sure that p0840 = r29659.0, p0844 = r29659.1, p1143 = r29640.0 and p1144 = r29641.

### Function description

- OFF1/OFF3: OFF3 disables frost protection function while OFF1 enables this function again.
- OFF2/fault: The motor stops and the frost protection function is deactivated.

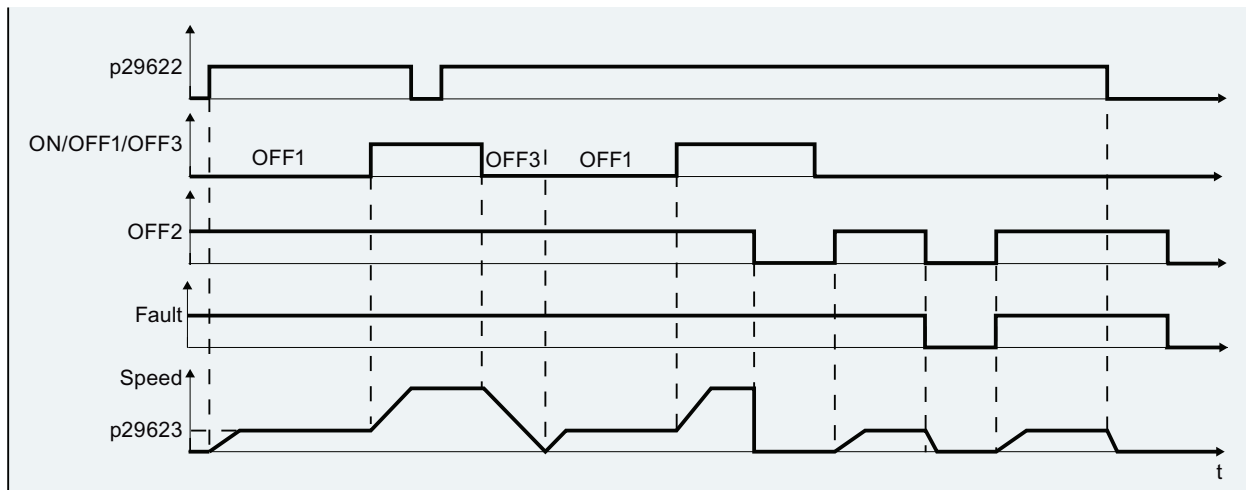

### Note

Frost protection can not run when Operator Panels (BOP-2 or IOP-2) or G120 Smart Access gets control of the motor.

### Parameters

Number	Name	Factory setting
p29622	BI: Frost protection enable	0
p29623	Frost protection speed	0 rpm



For more information about the parameters, see Chapter "Parameters (Page 373)".

### 6.3.3 Condensation protection

#### Overview



Condensation is a serious problem for motors in the humid and cold environment, resulting in motor failure. This problem can be avoided by slightly increasing the surface temperature of the motor during work break. If an external condensation sensor detects excessive condensation, the converter applies a DC current to keep the motor warm to prevent condensation.

#### Precondition

Before enabling the condensation protection, make sure that p0840 = r29659.0, p0844 = r29659.1, p1143 = r29640.0 and p1144 = r29641.

#### Function description

- OFF1/OFF3: OFF3 disables the condensation protection function while OFF1 enables this function again.
- OFF2/fault: The motor stops and the condensation protection function is deactivated.

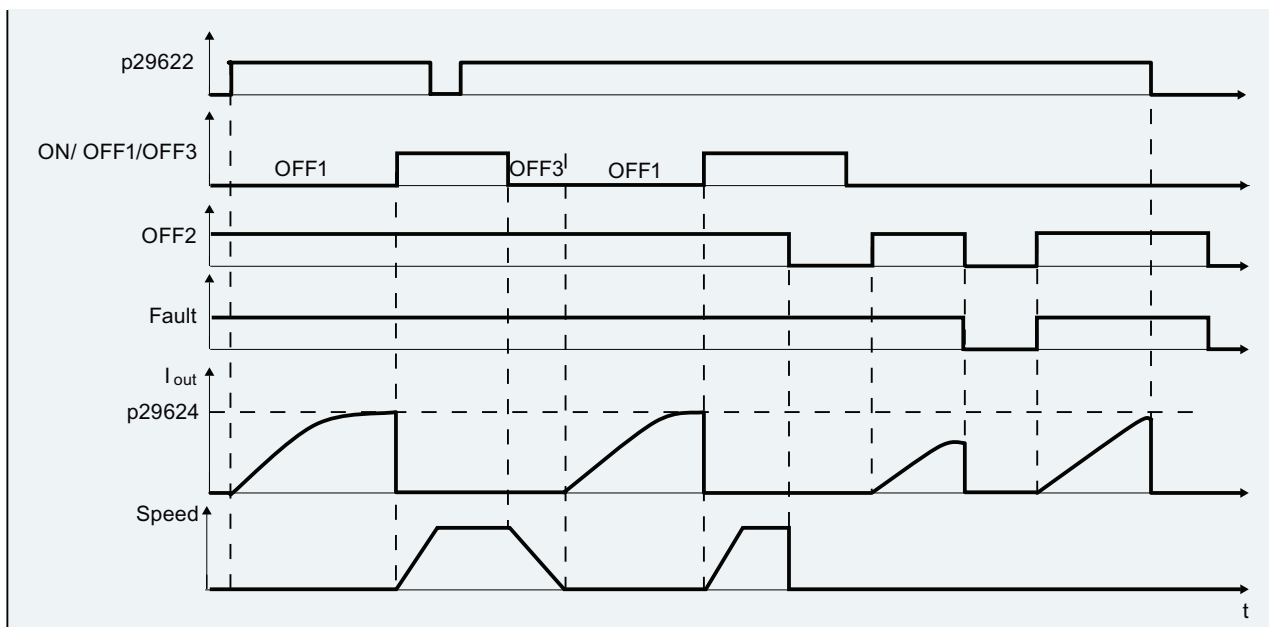

If the converter is not running and the protection signal becomes active, protection measure is applied as follows:

- If frost protection speed p29623 ≠ 0 (default 0), frost protection is activated by applying the specified speed to the motor.
- If frost protection speed p29623 = 0 and condensation protection current p29624 ≠ 0, condensation protection is activated by applying the specified current to the motor.



## Parameters

Number	Name	Factory setting
p29622	BI: Frost protection enable	0
p29624	Condensation protection current	30%

 For more information about the parameters, see Chapter "Parameters (Page 373)".

### 6.3.4 Cavitation protection

#### Overview



Cavitation problem can damage the impeller of the pumps, reduce the output water flow and cause unexpected noise. The cavitation protection will generate a fault/warning when cavitation conditions are deemed to be present. If the converter gets no feedback from the pump transducer, it will trip to prevent cavitation damage. This function saves the maintenance efforts and extends the lifetime expectancy of the system.

#### Function description

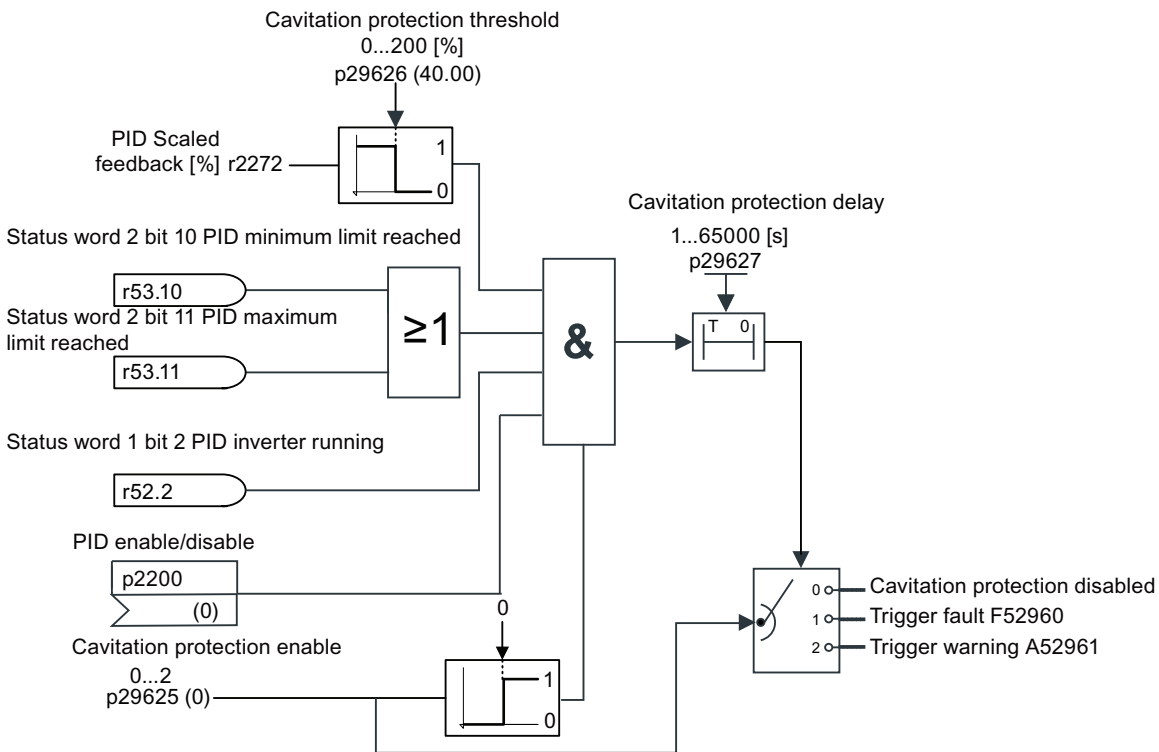

#### Parameters

Number	Name	Factory setting
p29625	Cavitation protection enable	0
p29626	Cavitation protection threshold	40%
p29627	Cavitation protection time	30 s

For more information about the parameters, see Chapter "Parameters (Page 373)".

## 6.3.5 Deragging

### Overview



Blockage in the wastewater pumps can reduce the efficiency of the system. With the deragging function, any clogs on the pump impellers, pipes or valves can be cleared automatically. This function saves the maintenance efforts for manually cleaning the pumps.

### Precondition

Before enabling the deragging, make sure that  $p1143 = r29640.0$  and  $p1144 = r29641$ .

### Function description

The deragging mode consists of forward and reverse runs of the motors. Parameter  $p29590$  is used to select the deragging mode.

- $p29590 = 1$ : enabled on first run after power-up
- $p29590 = 2$ : enabled on every run
- $p29590 = 3$ : enabled with a Binector input ( $p29591$ )

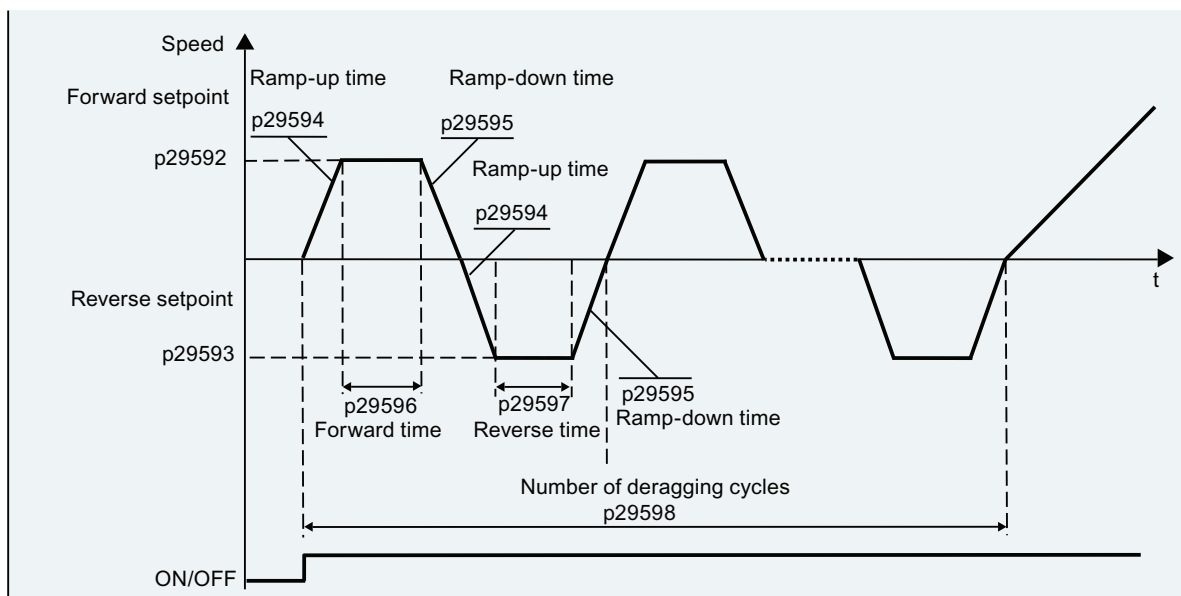

### Parameters

Number	Name	Factory setting
$p29590$	Deragging mode	0
$p29591$	BI: Deragging enable	0
$p29592$	Deragging forward speed	500 rpm
$p29593$	Deragging reverse speed	500 rpm

Number	Name	Factory setting
p29594	Ramp-up time	5 s
p29595	Ramp-down time	5 s
p29596	Deragging forward time	5 s
p29597	Deragging reverse time	5 s
p29598	Deragging cycle	1

Note: Before enabling the deragging via p29590, make sure the converter is in OFF status.



For more information about the parameters, see Chapter "Parameters (Page 373)".

### Interaction with other functions

- Deragging signal is ignored if the converter is restarted under the command of essential service mode, bypass operation, automatic restart, hibernation mode or multi-pump switching-in.
- Deragging is interrupted if essential service mode, bypass, or hibernation mode is activated.

## 6.3.6 Pipe filling

### Overview



In the water supply systems, the rapid inrush of water into an empty pipe can cause hammer effect and thus damage the pipe or the valve. With the pipe filling function enabled, the converter fills the pipe slowly and smoothly after each power-up to avoid hammer effect to the pipe. If the pipe filling is interrupted (for example, fault occurs), the function continues after the converter is recovered. This function is used in horizontal, vertical, and mixed piping systems.

### Precondition

Before enabling the pipe filling, make sure that  $p1143 = r29640.0$  and  $p1144 = r29641$ .

### Function description

After the pipe filling is enabled, you can select from the following two filling modes:

- Time mode: p29611 = 0  
The converter fills the pipe with a low speed for a specified time (p29613) and then changes the speed to the setpoint.

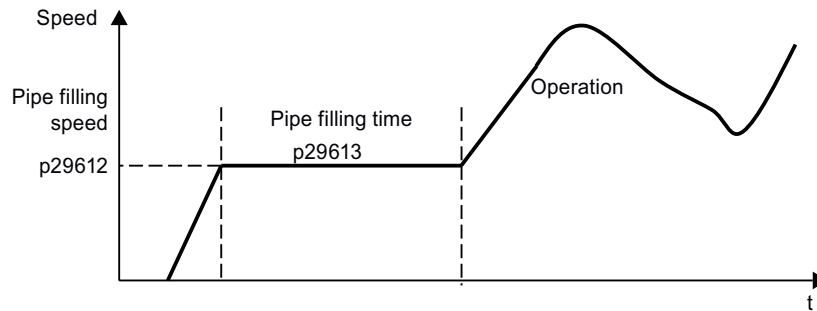

- Pressure mode: p29611 = 1  
The converter fills the pipe according to the PID feedback from the pressure sensor. The filling stops when the actual pressure (r2272)  $\geq$  the threshold (p29614) for a specified time (p29615).

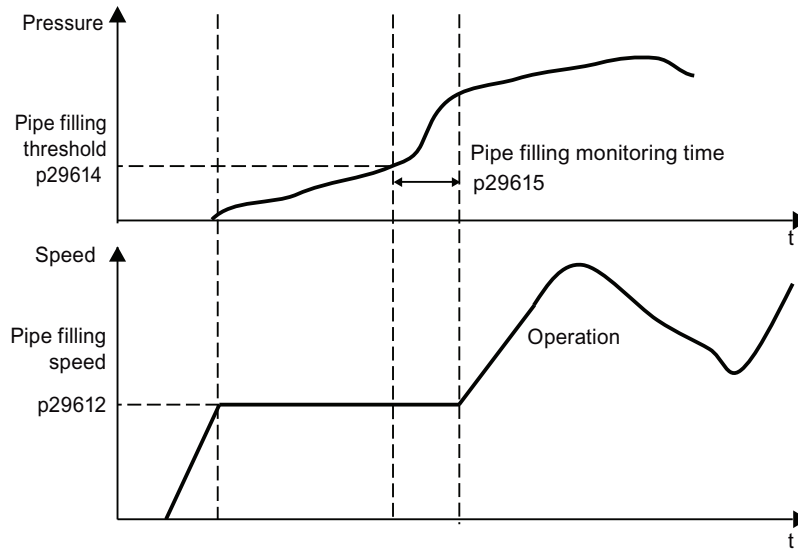

---

#### Note

##### Priority of frost protection, condensation protection, deragging and pipe filling

The priority of functions is as follows: frost protection > condensation protection > deragging > pipe filling.

---

## Parameters

Number	Name	Factory setting
p29610	Pipe filling enable	0
p29611	Pipe filling mode	0
p29612	Pipe filling speed	900 rpm
p29613	Pipe filling time	50 s
p29614	Pipe filling threshold	10%
p29615	Pipe filling monitoring time	0 s



For more information about the parameters, see Chapter "Parameters (Page 373)".

## 6.4 Setpoints and setpoint processing

### 6.4.1 Setpoints

#### Overview



The converter receives its main setpoint from the setpoint source. The main setpoint generally specifies the motor speed.

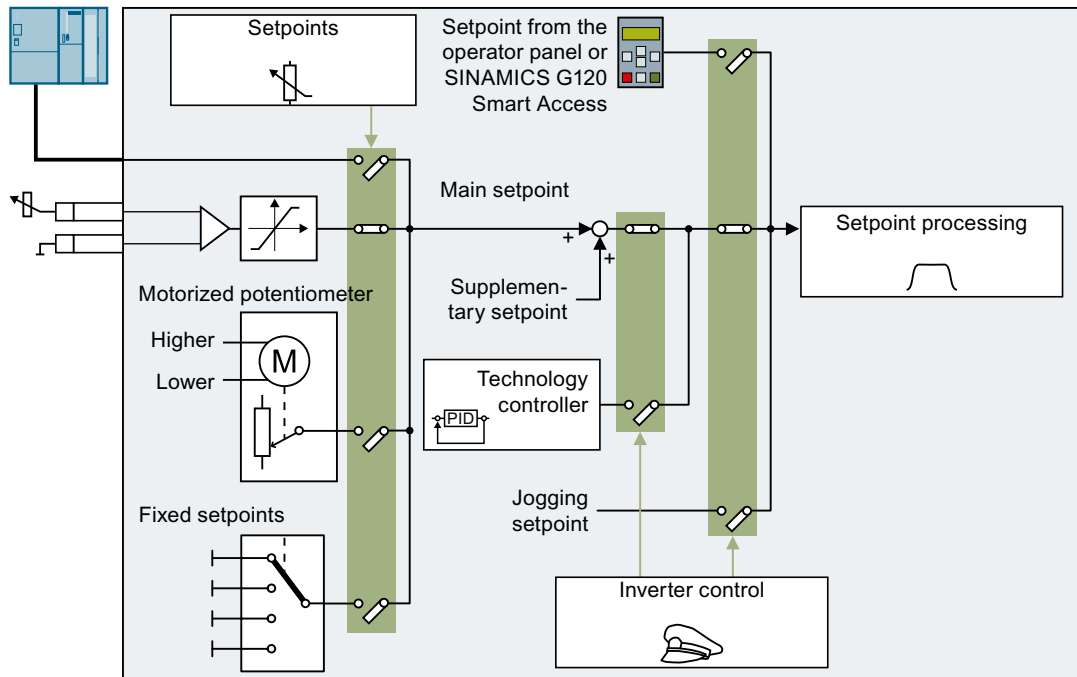

Figure 6-28 Setpoint sources for the converter

You have the following options when selecting the source of the main setpoint:

- Converter fieldbus interface
- Analog input of the converter
- Motorized potentiometer emulated in the converter
- Fixed setpoints saved in the converter

You have the same selection options when selecting the source of the supplementary setpoint.

Under the following conditions, the converter switches from the main setpoint to other setpoints:

- When the technology controller is active and appropriately interconnected, its output specifies the motor speed.
- When jogging is active
- When controlling from an operator panel
- When controlling from SINAMICS G120 Smart Access



### 6.4.1.1 Analog input as setpoint source

#### Function description

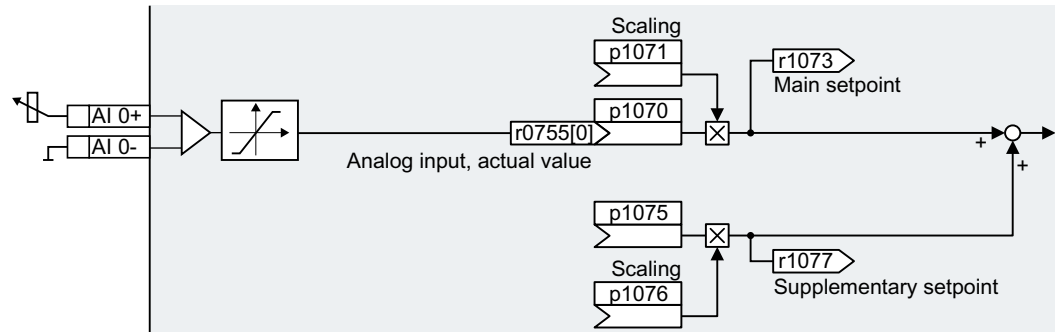

Figure 6-29 Example: Analog input 0 as setpoint source

In the quick commissioning, you define the preassignment for the converter interfaces. Depending on what has been preassigned, after quick commissioning, the analog input can be interconnected with the main setpoint.

#### Example

Setting with analog input 0 as setpoint source:

Parameter	Description
p1070 = 755[0]	Interconnects main setpoint with analog input 0
p1075 = 755[0]	Interconnects supplementary setpoint with analog input 0

#### Parameters

Number	Name	Factory setting
r0755[0 ... 1]	CO: CU analog inputs, actual value in percent	- %
p1070[C]	CI: Main setpoint	Dependent on the converter
p1071[C]	CI: Main setpoint scaling	1
r1073	CO: Main setpoint active	- rpm
p1075[C]	CI: Supplementary setpoint	0
p1076[C]	CI: Supplementary setpoint scaling	1
r1077	CO: Supplementary setpoint effective	- rpm

6.4.1.2 Specifying the setpoint via the fieldbus

Function description

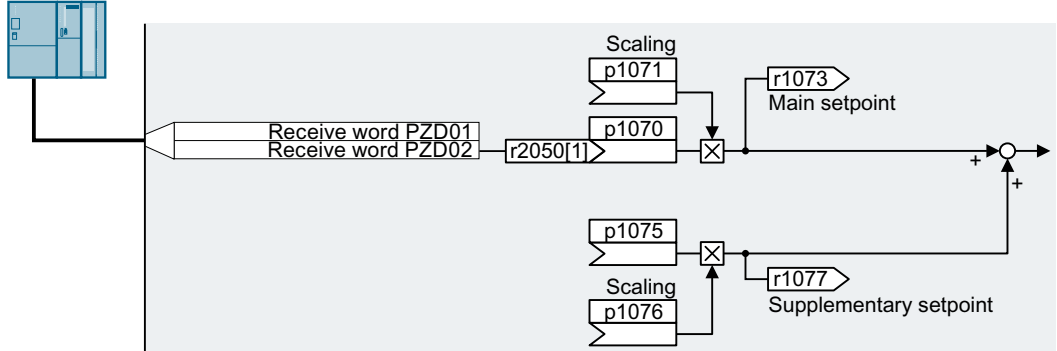

Figure 6-30 Fieldbus as setpoint source

In the quick commissioning, you define the preassignment for the converter interfaces. Depending on what has been preassigned, after quick commissioning, the receive word PZD02 can be interconnected with the main setpoint.

Example

Setting with receive word PZD02 as setpoint source:

Parameter	Description
p1070 = 2050[1]	Interconnects the main setpoint with the receive word PZD02 from the fieldbus.
p1075 = 2050[1]	Interconnects the supplementary setpoint with receive word PZD02 from the fieldbus.

Parameters

Number	Name	Factory setting
p1070[C]	CI: Main setpoint	Dependent on the converter
p1071[C]	CI: Main setpoint scaling	1
r1073	CO: Main setpoint active	- rpm
p1075[C]	CI: Supplementary setpoint	0
p1076[C]	CI: Supplementary setpoint scaling	1
r1077	CO: Supplementary setpoint effective	- rpm
r2050[0...11]	CO: PROFIdrive PZD receive word	-

### 6.4.1.3 Motorized potentiometer as setpoint source

#### Function description

The "Motorized potentiometer" function emulates an electromechanical potentiometer. The output value of the motorized potentiometer can be set with the "higher" and "lower" control signals.

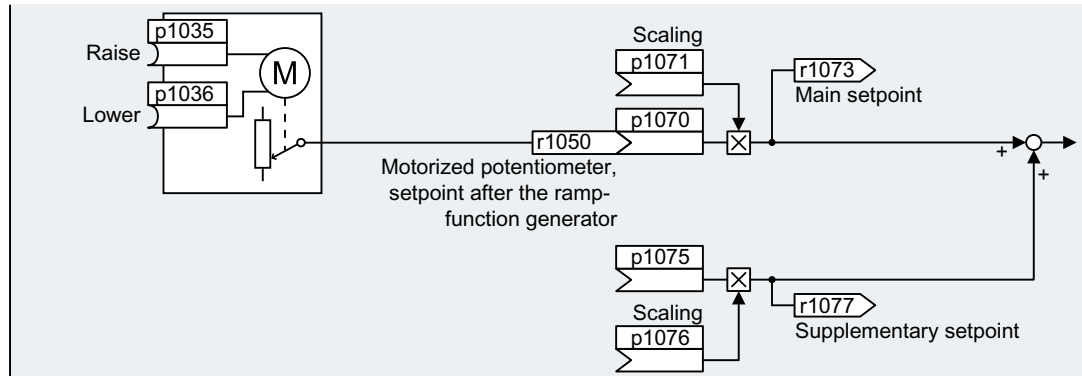

Figure 6-31 Motorized potentiometer as setpoint source

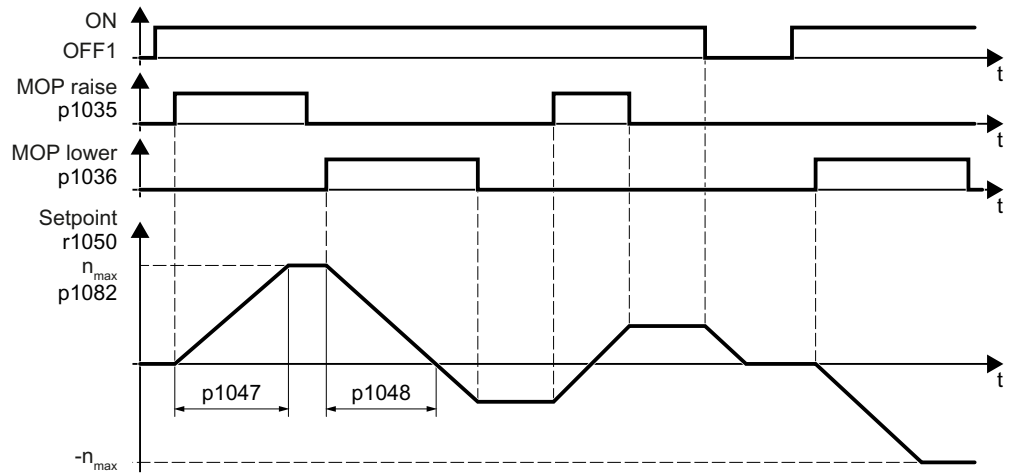

Figure 6-32 Function chart of the motorized potentiometer

#### Example

Setting with the motorized potentiometer as setpoint source:

Parameter	Description
p1070 = 1050	Interconnects the main setpoint with the motorized potentiometer output.

Function diagram

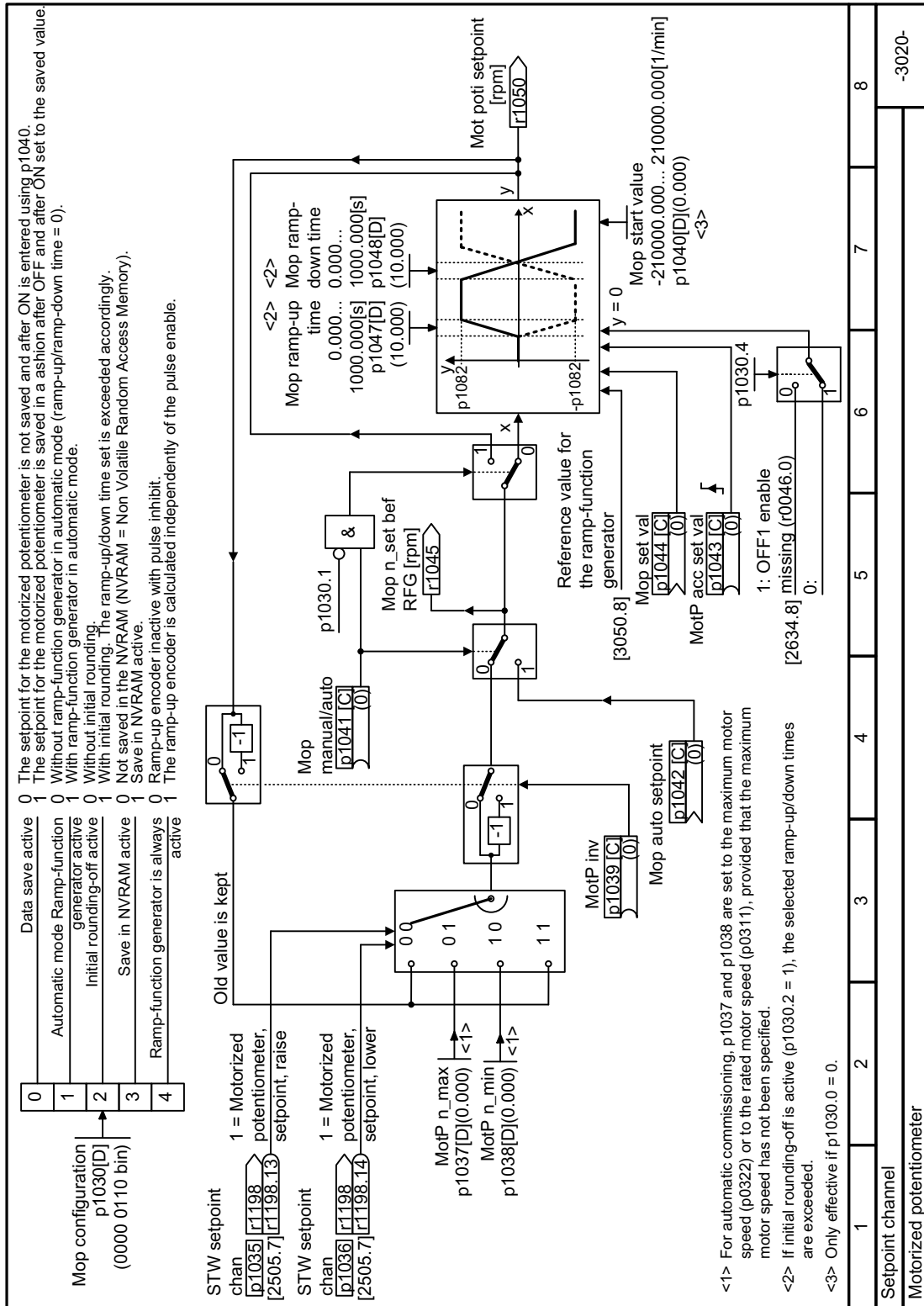

Figure 6-33 FP 3020

## Parameters

Table 6-43 Basic setup of motorized potentiometer

Number	Name	Factory setting
p1035[C]	Bl: Motorized potentiometer setpoint higher	0
p1036[C]	Bl: Motorized potentiometer setpoint lower	Dependent on the converter
p1040[D]	Motorized potentiometer start value	0 rpm
p1047[D]	Motorized potentiometer, ramp-up time	10 s
p1048[D]	Motorized potentiometer, ramp-down time	10 s
r1050	Motorized potentiometer, setpoint after the ramp-function generator	- rpm
p1070[C]	Cl: Main setpoint	Dependent on the converter
p1071[C]	Cl: Main setpoint scaling	1
r1073	CO: Main setpoint active	- rpm
p1075[C]	Cl: Supplementary setpoint	0
p1076[C]	Cl: Supplementary setpoint scaling	1

Table 6-44 Extended setup of motorized potentiometer

Number	Name	Factory setting
p1030[D]	Motorized potentiometer configuration	0000 0110 bin
p1037[D]	Motorized potentiometer, maximum speed	0 rpm
p1038[D]	Motorized potentiometer, minimum speed	0 rpm
p1043[C]	Bl: Motorized potentiometer, accept setting value	0
p1044[C]	Cl: Motorized potentiometer, setting value	0

6.4.1.4 Fixed speed setpoint as setpoint source

Function description

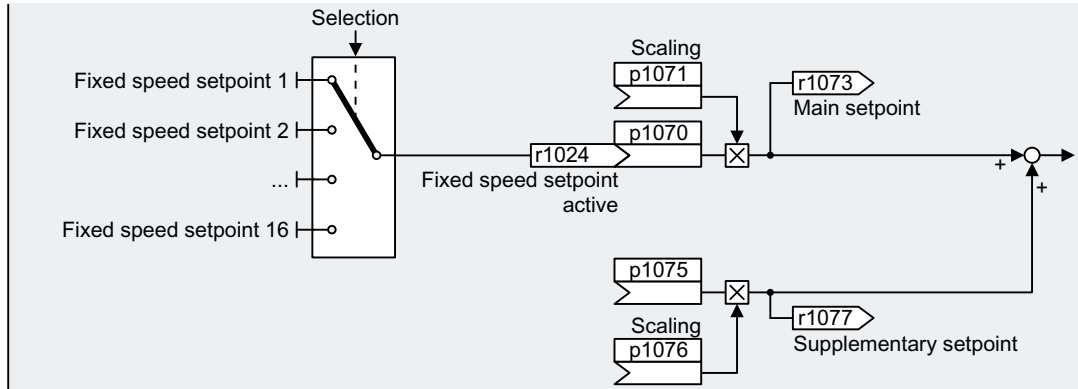

Figure 6-34 Fixed speed setpoint as setpoint source

The converter makes a distinction between two methods when selecting the fixed speed setpoints:

Directly selecting a fixed speed setpoint

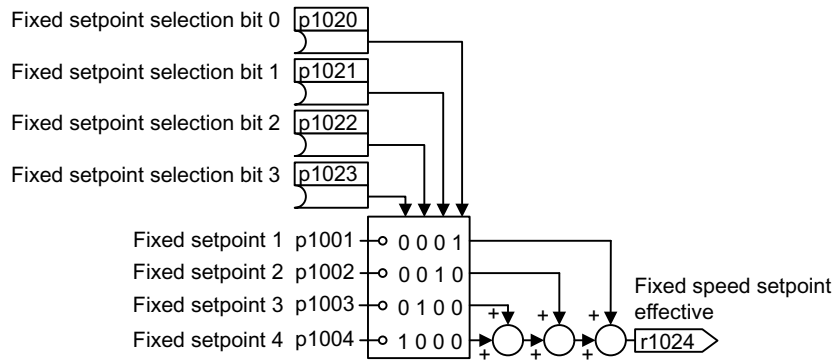

Figure 6-35 Direct selection of the fixed speed setpoint

Table 6-45 Resulting setpoint

p1020	p1021	p1022	p1023	Resulting setpoint
0	0	0	0	0
1	0	0	0	p1001
0	1	0	0	p1002
1	1	0	0	p1001 + p1002
0	0	1	0	p1003
1	0	1	0	p1001 + p1003
0	1	1	0	p1002 + p1003
1	1	1	0	p1001 + p1002 + p1003
0	0	0	1	p1004
1	0	0	1	p1001 + p1004

p1020	p1021	p1022	p1023	Resulting setpoint
0	1	0	1	p1002 + p1004
1	1	0	1	p1001 + p1002 + p1004
0	0	1	1	p1003 + p1004
1	0	1	1	p1001 + p1003 + p1004
0	1	1	1	p1002 + p1003 + p1004
1	1	1	1	p1001 + p1002 + p1003 + p1004

**Selecting the fixed speed setpoint, binary**

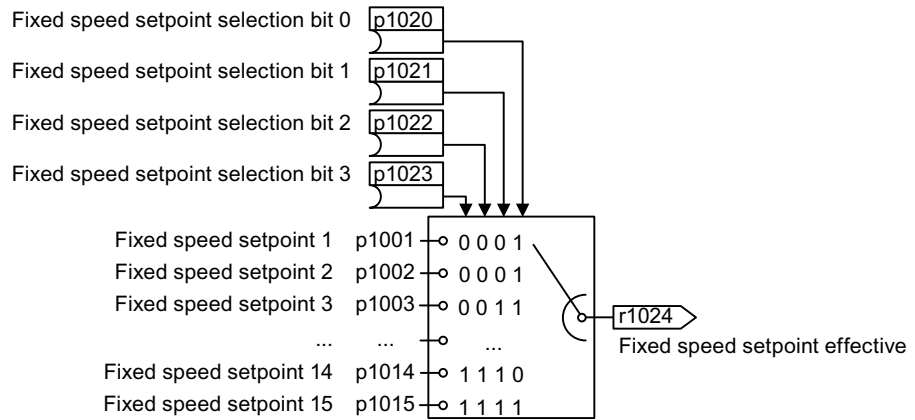

Figure 6-36 Binary selection of the fixed speed setpoint

Table 6-46 Resulting setpoint

p1020	p1021	p1022	p1023	Resulting setpoint
0	0	0	0	0
1	0	0	0	p1001
0	1	0	0	p1002
1	1	0	0	p1003
0	0	1	0	p1004
1	0	1	0	p1005
0	1	1	0	p1006
1	1	1	0	p1007
0	0	0	1	p1008
1	0	0	1	p1009
0	1	0	1	p1010
1	1	0	1	p1011
0	0	1	1	p1012
1	0	1	1	p1013
0	1	1	1	p1014
1	1	1	1	p1015

Function diagrams

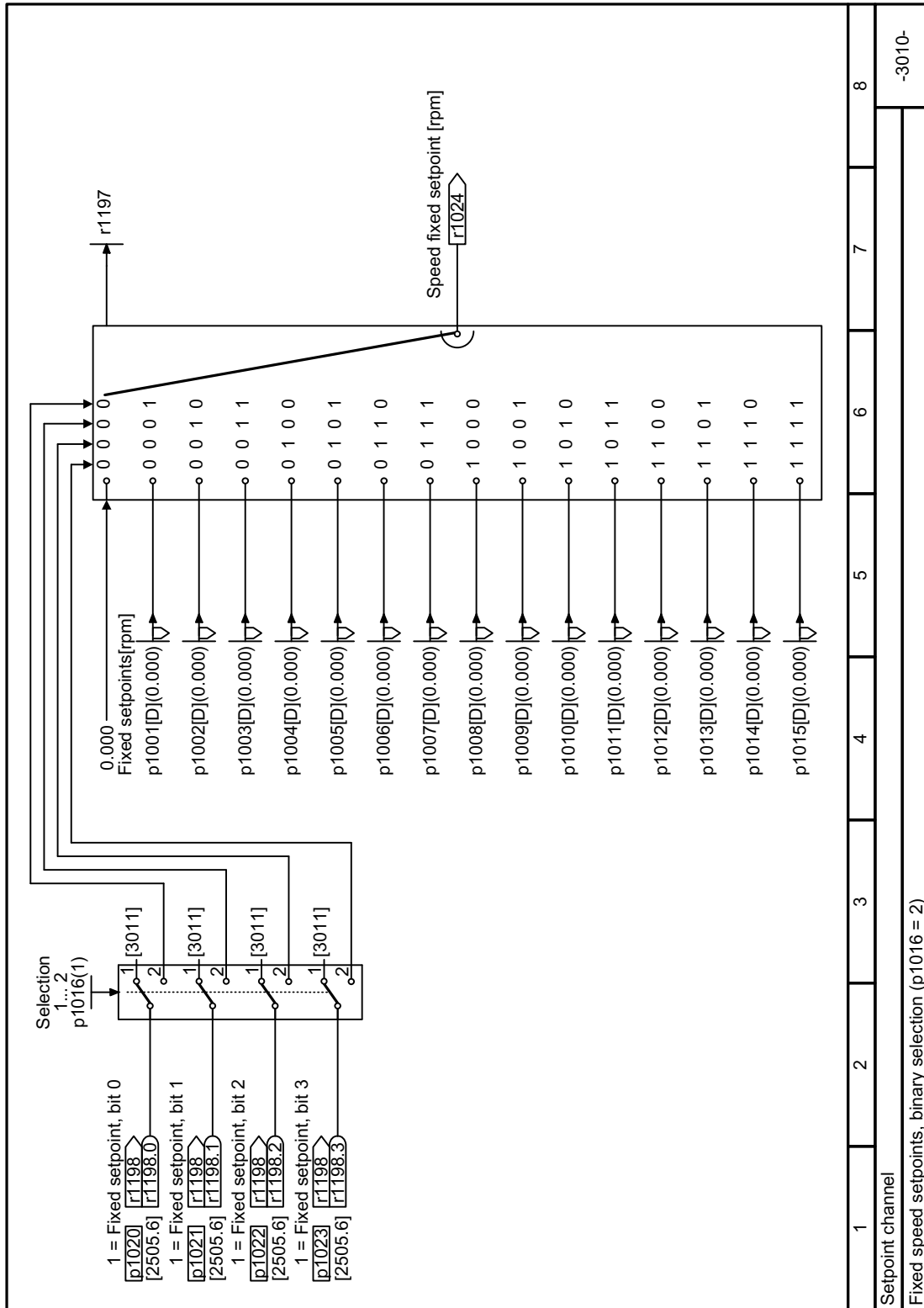

Figure 6-37 FP 3010



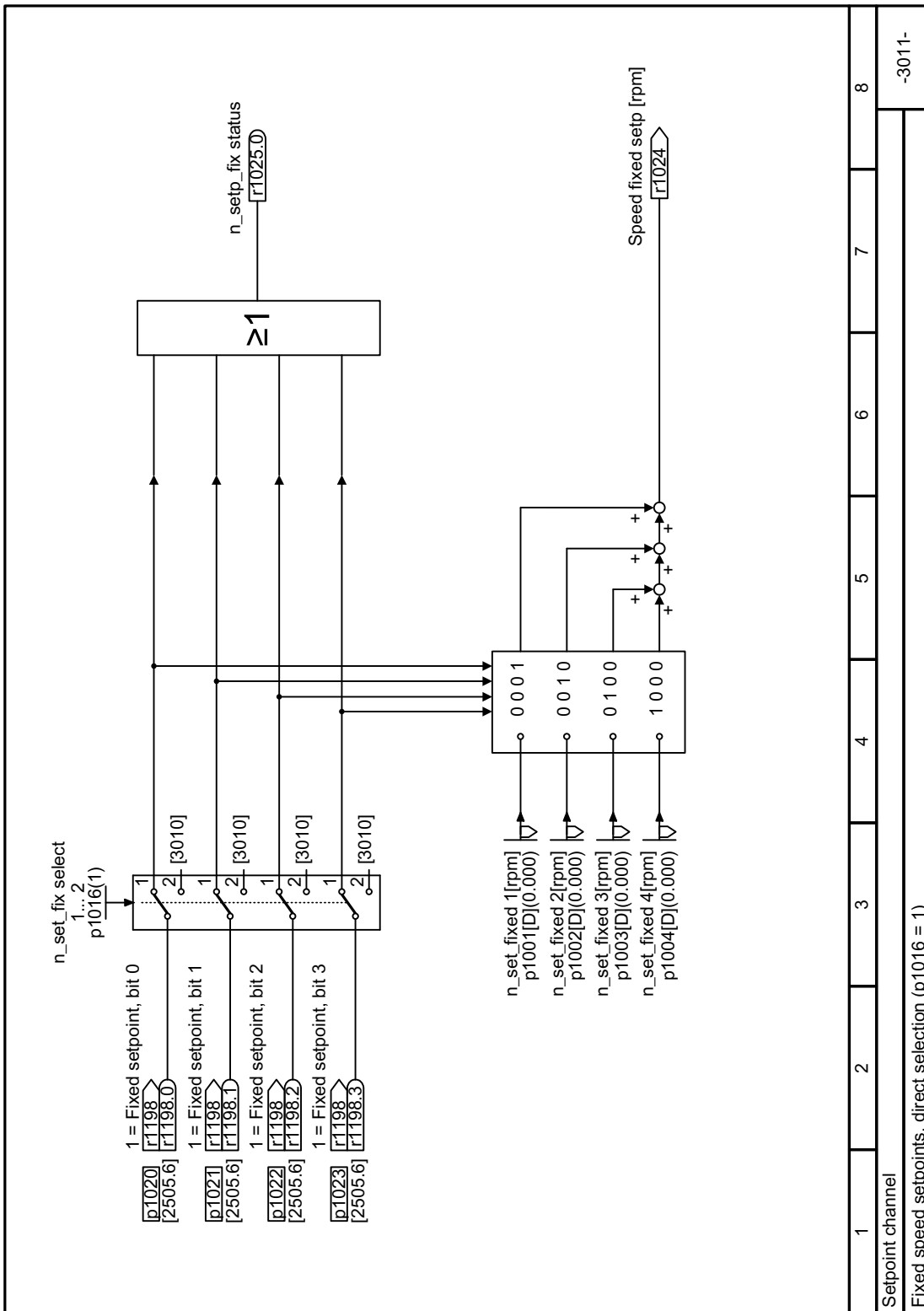

Figure 6-38 FP 3011

## Parameter

Number	Name	Factory setting
p1001[D]	CO: Fixed speed setpoint 1	0 rpm
p1002[D]	CO: Fixed speed setpoint 2	0 rpm
p1003[D]	CO: Fixed speed setpoint 3	0 rpm
p1004[D]	CO: Fixed speed setpoint 4	0 rpm
p1005[D]	CO: Fixed speed setpoint 5	0 rpm
p1006[D]	CO: Fixed speed setpoint 6	0 rpm
p1007[D]	CO: Fixed speed setpoint 7	0 rpm
p1008[D]	CO: Fixed speed setpoint 8	0 rpm
p1009[D]	CO: Fixed speed setpoint 9	0 rpm
p1010[D]	CO: Fixed speed setpoint 10	0 rpm
p1011[D]	CO: Fixed speed setpoint 11	0 rpm
p1012[D]	CO: Fixed speed setpoint 12	0 rpm
p1013[D]	CO: Fixed speed setpoint 13	0 rpm
p1014[D]	CO: Fixed speed setpoint 14	0 rpm
p1015[D]	CO: Fixed speed setpoint 15	0 rpm
p1016	Fixed speed setpoint selection mode	1
p1020[C]	Fixed speed setpoint selection, bit 0	0
p1021[C]	Fixed speed setpoint selection, bit 1	0
p1022[C]	Fixed speed setpoint selection, bit 2	0
p1023[C]	Fixed speed setpoint selection, bit 3	0
r1024	Fixed speed setpoint active	- rpm
r1025.0	Fixed speed setpoint status	-
p1070[C]	CI: Main setpoint	Dependent on the converter
p1071[C]	CI: Main setpoint scaling	1
r1073	CO: Main setpoint active	- rpm
p1075[C]	CI: Supplementary setpoint	0
p1076	CI: Supplementary setpoint scaling	1
r1077	CO: Supplementary setpoint effective	- rpm

## 6.4.2 Setpoint processing

### 6.4.2.1 Overview

#### Overview



Setpoint processing influences the setpoint using the following functions:

- "Invert" inverts the motor direction of rotation.
- The "direction of rotation deactivate" function prevents the motor rotating in the incorrect direction.
- The "Skip frequency bands" prevent the motor from being continuously operated within these skip bands. This function avoids mechanical resonance effects by only permitting the motor to operate briefly at specific speeds.
- The "Speed limitation" function protects the motor and the driven load against excessively high speeds.
- The "Ramp-function generator" function prevents the setpoint from suddenly changing. As a consequence, the motor accelerates and brakes with a reduced torque.

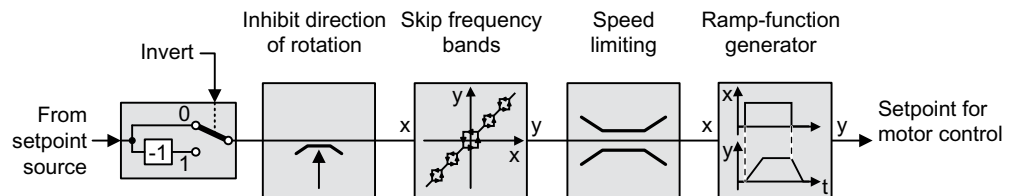
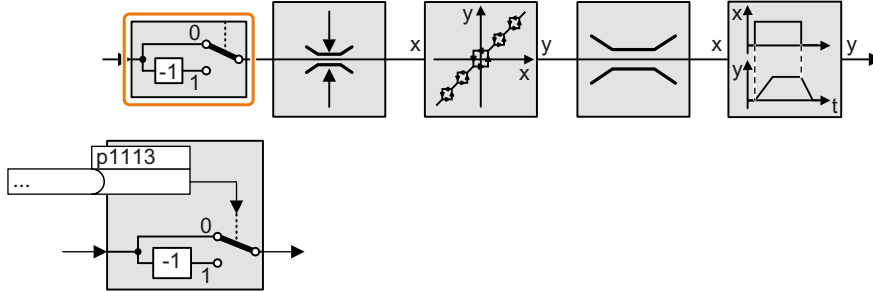

Figure 6-39 Setpoint processing in the converter

6.4.2.2 Invert setpoint

Function description



The function inverts the sign of the setpoint using a binary signal.

Example

To invert the setpoint via an external signal, interconnect parameter p1113 with a binary signal of your choice.

Table 6-47 Application examples showing how a setpoint is inverted

Parameter	Description
p1113 = 722.1	Digital input 1 = 0: Setpoint remains unchanged. Digital input 1 = 1: Converter inverts the setpoint.
p1113 = 2090.11	Inverts the setpoint via the fieldbus (control word 1, bit 11).

Parameter

Number	Name	Factory setting
p1113[C]	BI: Setpoint inversion	Dependent on the converter

### 6.4.2.3 Enable direction of rotation

#### Function description

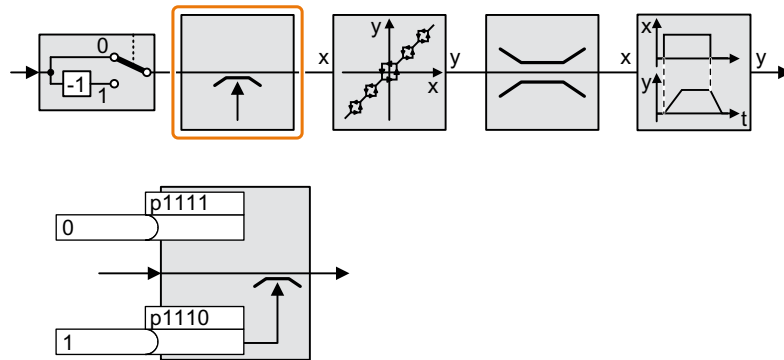

In the factory setting of the converter, the negative direction of rotation of the motor is inhibited.  
Set parameter p1110 = 0 to permanently enable the negative direction of rotation.  
Set parameter p1111 = 1 to permanently inhibit the positive direction of rotation.

#### Parameters

Table 6-48 Application examples for inhibiting and enabling the direction of rotation

Number	Name	Factory setting
p1110	BI: Inhibit negative direction	1
p1111	BI: Inhibit positive direction	0

### 6.4.2.4 Skip frequency bands and minimum speed

#### Overview

The converter has a minimum speed and four skip frequency bands:

- The minimum speed prevents continuous motor operation at speeds less than the minimum speed.
- Each skip frequency band prevents continuous motor operation within a specific speed range.

#### Function description

##### Minimum speed

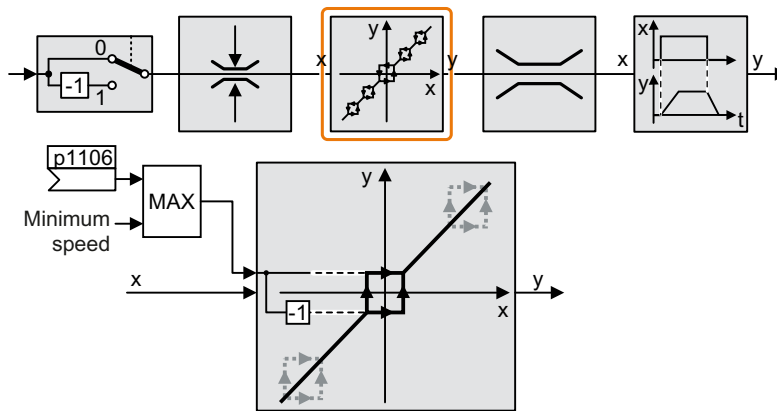

Speeds where the absolute value is less than the minimum speed are only possible when the motor is accelerating or braking.

##### Skip frequency bands

Further information on the skip frequency bands is provided in the function block diagram.

Function diagram

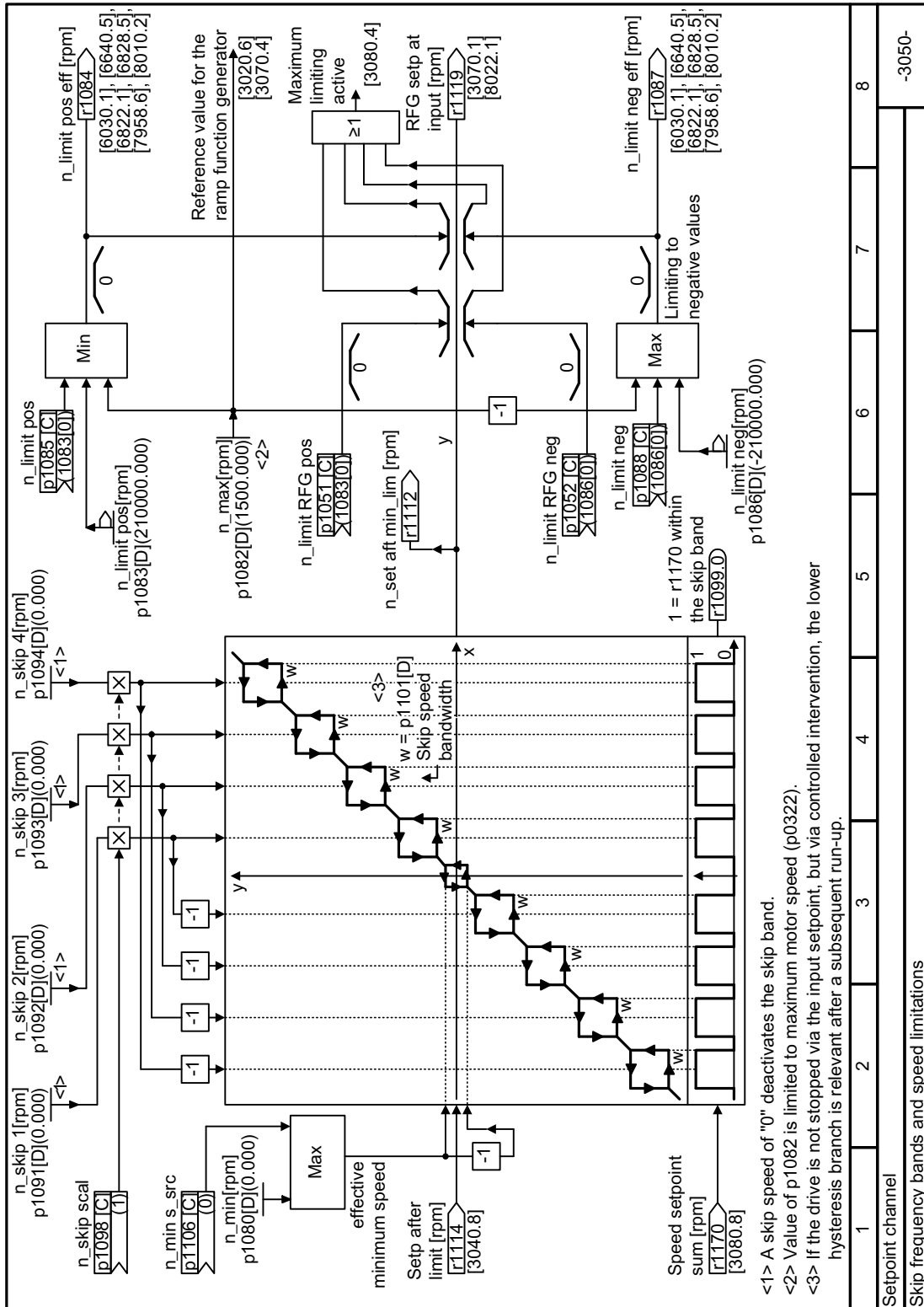

Figure 6-40 FD 3050

Parameters

Table 6-49 Minimum speed

Number	Name	Factory setting
p1051[C]	Cl: Speed limit of ramp-function generator, positive direction of rotation	9733
p1052[C]	Cl: Speed limit of ramp-function generator, negative direction of rotation	1086
p1080[D]	Minimum speed	0 rpm
p1083[D]	CO: Speed limit in positive direction of rotation	210000 rpm
r1084	CO: Speed limit positive active	- rpm
p1085[C]	Cl: Speed limit in positive direction of rotation	1083
p1091[D]	Skip speed 1	0 rpm
p1092[D]	Skip speed 2	0 rpm
p1093[D]	Skip speed 3	0 rpm
p1094[D]	Skip speed 4	0 rpm
p1098[C]	Cl: Skip speed scaling	1
r1099	CO/BO: Skip frequency band of status word	-
p1106	Cl: Minimum speed signal source	0
r1112	CO: Speed setpoint according to minimum limit	- rpm
r1114	CO: Setpoint after direction limiting	- rpm
r1119	CO: Ramp-function generator setpoint at the input	- rpm
r1170	CO: Speed controller setpoint sum	- rpm

Further information is provided in the parameter list.

 Parameters (Page 373)

<p><b>NOTICE</b></p> <p><b>Incorrect direction of motor rotation if the parameterization is not suitable</b></p> <p>If you are using an analog input as speed setpoint source, then for a setpoint = 0 V, noise voltages can be superimposed on the analog input signal. After the on command, the motor accelerates up to the minimum frequency in the direction of the random polarity of the noise voltage. A motor rotating in the wrong direction can cause significant material damage to the machine or system.</p> <ul style="list-style-type: none"> <li>• Inhibit the motor direction of rotation that is not permissible.</li> </ul>
---



### 6.4.2.5 Speed limitation

The maximum speed limits the speed setpoint range for both directions of rotation.

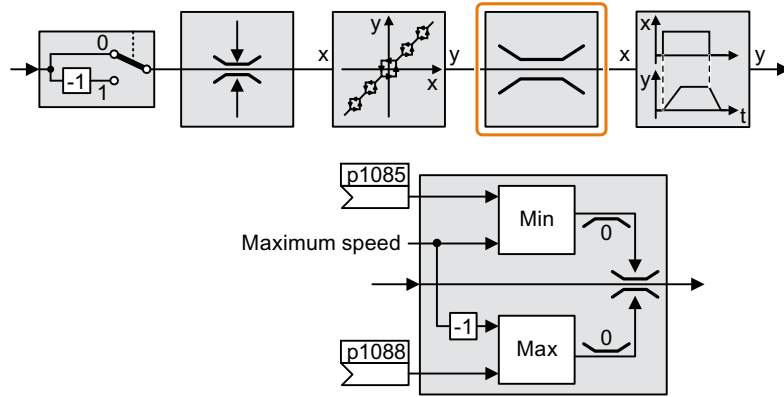

The converter generates a message (fault or alarm) when the maximum speed is exceeded.

If you must limit the speed depending on the direction of rotation, then you can define speed limits for each direction.

## Parameters

Table 6-50 Parameters for the speed limitation

Number	Name	Factory setting
p1082[D]	Maximum speed	1500 rpm
p1083[D]	CO: Speed limit in positive direction of rotation	210000 rpm
p1085[C]	CI: Speed limit in positive direction of rotation	1083
p1086[D]	CO: Speed limit in negative direction of rotation	-210000 rpm
p1088[C]	CI: Speed limit in negative direction of rotation	1086

### 6.4.2.6 Ramp-function generator

The ramp-function generator in the setpoint channel limits the rate change of the speed setpoint (acceleration). A reduced acceleration reduces the accelerating torque of the motor. As a consequence, the motor reduces the stress on the mechanical system of the driven machine.

The extended ramp-function generator not only limits the acceleration, but by rounding the setpoint, also acceleration changes (jerk). This means that the motor does not suddenly generate a torque.

### Extended ramp-function generator

The ramp-up and ramp-down times of the extended ramp-function generator can be set independently of each other. The optimal times depend on the application, and can lie in the range from a few 100 ms to several minutes.

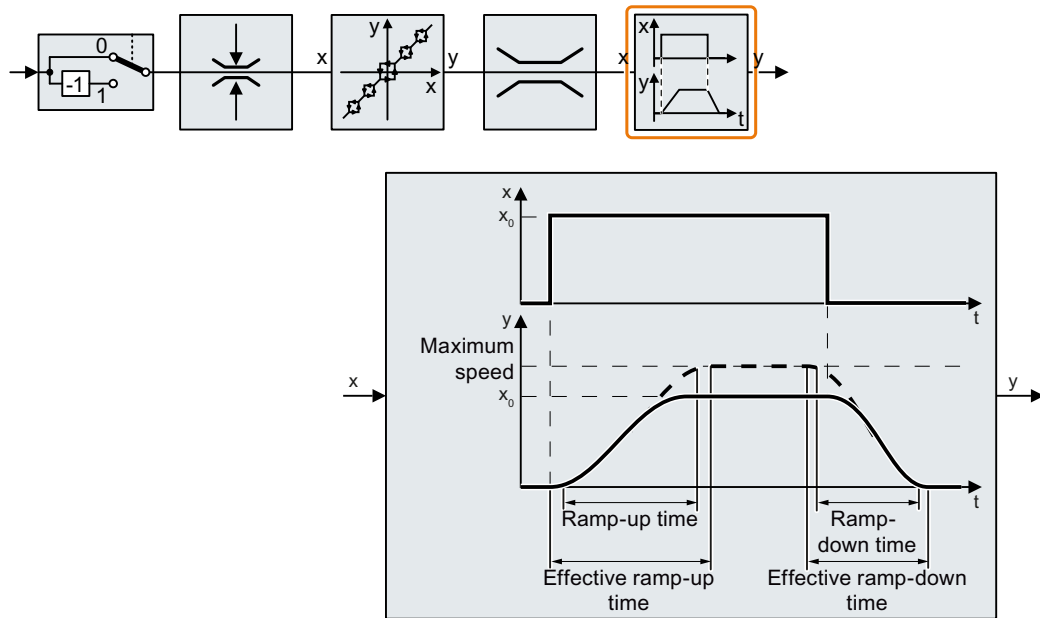

Initial and final rounding permit smooth, jerk-free acceleration and braking.

The ramp-up and ramp-down times of the motor are increased by the rounding times:

- Effective ramp-up time =  $p1120 + 0.5 \times (p1130 + p1131)$ .
- Effective ramp-down time =  $p1121 + 0.5 \times (p1130 + p1131)$ .



**Parameters**

Table 6-51 Additional parameters to set the extended ramp-function generator

Number	Name	Factory setting
p1120[D]	Ramp-function generator ramp-up time	Dependent on the converter
p1121[D]	Ramp-function generator ramp-down time	
p1130[D]	Ramp-function generator initial rounding time	
p1131[D]	Ramp-function generator final rounding time	
p1134[D]	Ramp-function generator rounding type	0 (continuous smoothing)
p1135[D]	OFF3 ramp-down time	Dependent on the converter
p1136[D]	OFF3 initial rounding time	
p1137[D]	OFF3 final rounding time	0 s
p1138[C]	CI: Ramp-function generator ramp-up time scaling	1
p1139[C]	CI: Ramp-function generator ramp-down time scaling	1
p1140[C]	BI: Enable ramp-function generator/disable ramp-function generator	Dependent on the converter
p1141[C]	BI: Continue ramp-function generator/freeze ramp-function generator	
p1142[C]	BI: Enable setpoint/inhibit setpoint	1
p1143[C]	BI: Accept ramp-function generator setting value	0
p1144[C]	CI: Ramp-function generator setting value	0
p1148[D]	Ramp-function generator tolerance for ramp-up and ramp-down active	19.8 rpm
r1149	CO: Ramp-function generator acceleration	-

Further information is provided in the parameter list.

**Setting the extended ramp-function generator**

**Procedure**

1. Enter the highest possible speed setpoint.
2. Switch on the motor.
3. Evaluate your drive response.
  - If the motor accelerates too slowly, then reduce the ramp-up time. An excessively short ramp-up time means that the motor will reach its current limiting when accelerating, and will temporarily not be able to follow the speed setpoint. In this case, the drive exceeds the set time.
  - If the motor accelerates too fast, then extend the ramp-up time.
  - Increase the initial rounding if the acceleration is jerky.
  - In most applications, it is sufficient when the final rounding is set to the same value as the initial rounding.
4. Switch off the motor.

5. Evaluate your drive response.
    - If the motor decelerates too slowly, then reduce the ramp-down time.  
The minimum ramp-down time that makes sense depends on your particular application. Depending on the Power Module used, for an excessively short ramp-down time, the converter either reaches the motor current, or the DC link voltage in the converter becomes too high.
    - Extend the ramp-down time if the motor is braked too quickly or the converter goes into a fault condition when braking.
  6. Repeat steps 1 ... 5 until the drive behavior meets the requirements of the machine or plant.
- You have set the extended ramp-function generator.

### 6.4.2.7 Dual ramp function

#### Overview

Submersible pumps suffer from insufficient cooling and lubrication when the pump speed is too low. The initial ramp-up accelerates the pump to the minimum speed to reduce the wear and tear. The long ramp time in the effective speed range improves the control accuracy for the pump and fan. The ramp-down decelerates the pump from the minimum speed to stop and thus reduces the shock to the valve.

#### Precondition

Before enabling the dual ramp function, make sure that  $p1138 = r29576$  and  $p1139 = r29577$ .

#### Function description

##### Ramp up

- Converter starts ramp-up using ramp time from  $p1120 \times p29570$ .
- When the actual speed  $r0063 > p29571$ , switch to ramp time from  $p1120 \times p29572$ .

##### Ramp down

- Converter starts ramp-down using ramp time from  $p1121 \times p29573$ .
- When the actual speed  $r0063 < p29574$ , switch to ramp time from  $p1121 \times p29575$ .

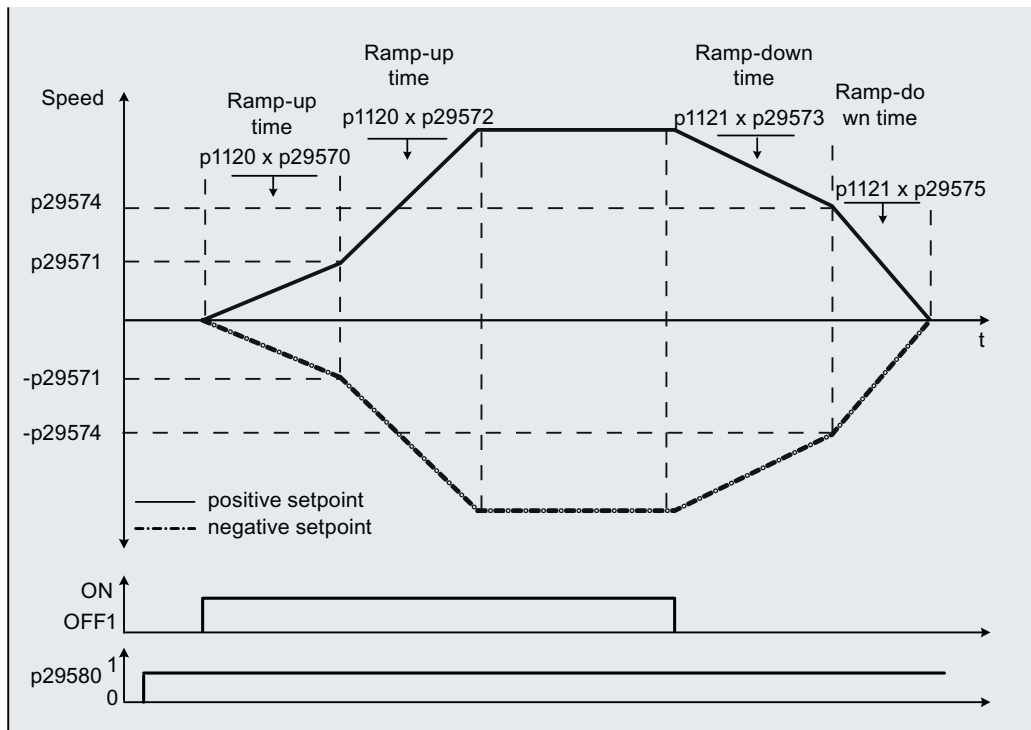

Parameters

Parameter	Description	Factory setting
p29570	DDS: Ramp-up scaling 1	100%
p29571	DDS: Threshold speed 2	30 rmp
p29572	DDS: Ramp-up scaling 2	100%
p29573	DDS: Ramp-down scaling 1	100%
p29574	DDS: Threshold speed 3	30 rmp
p29575	DDS: Ramp-down scaling 2	100%
r29576	CO: Ramp-up scaling output	-
r29577	CO: Ramp-down scaling output	-
p29578	CDS: Ramp-up scaling input	-
p29579	CDS: Ramp-down scaling input	-
p29580	BI: Dual ramp enable	0

For more information about the parameters, see Chapter "Parameters (Page 373)".

## 6.5 Technology controller

### 6.5.1 PID technology controller

#### Overview



The technology controller controls process variables, e.g. pressure, temperature, level or flow.

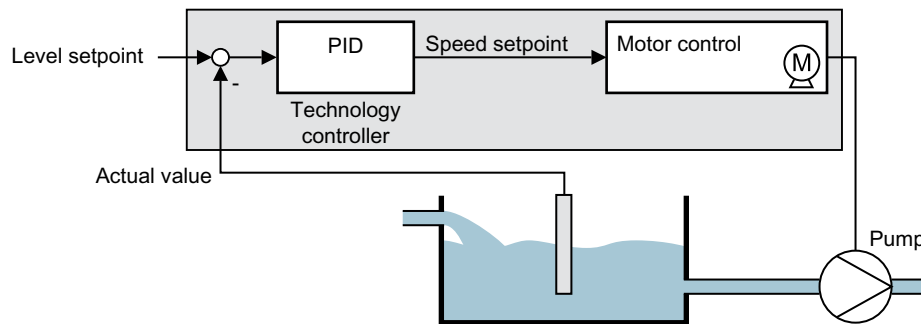

Figure 6-42 Example: Technology controller as a level controller

#### Precondition

##### Additional functions

The U/f control or the vector control have been set.

##### Tools

To change the function settings, you can use an operator panel, for example.

#### Function description

##### Function diagram

The technology controller is implemented as a PID controller (controller with proportional, integral, and derivative action).

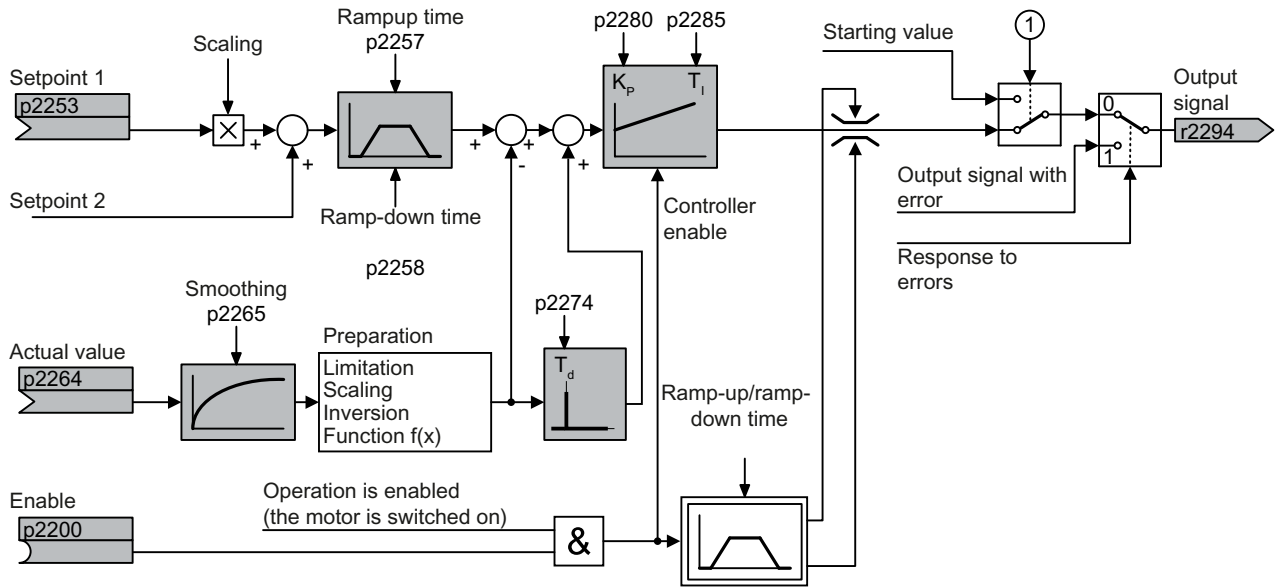

① The converter uses the start value when all the following conditions are simultaneously satisfied:

- The technology controller supplies the main setpoint (p2251 = 0).
- The ramp-function generator output of the technology controller has not yet reached the start value.

Figure 6-43 Simplified representation of the technology controller

**Basic settings**

The settings required as a minimum are marked in gray in the function diagram:

- Interconnect setpoint and actual values with signals of your choice
- Set ramp-function generator and controller parameters  $K_p$ ,  $T_i$  and  $T_d$ .



**Set controller parameters  $K_p$ ,  $T_i$  and  $T_d$ .****Procedure**

1. Temporarily set the ramp-up and ramp-down times of the ramp-function generator (p2257 and p2258) to zero.
2. Enter a setpoint step and monitor the associated actual value.  
The slower the response of the process to be controlled, the longer you must monitor the controller response. Under certain circumstances (e.g. for a temperature control), you need to wait several minutes until you can evaluate the controller response.

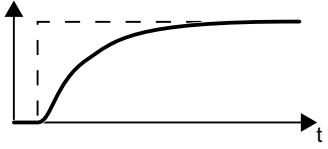
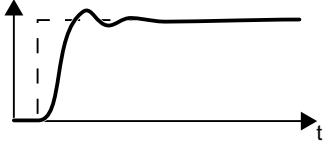
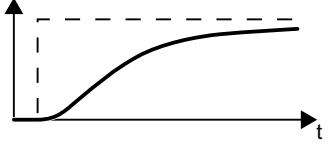
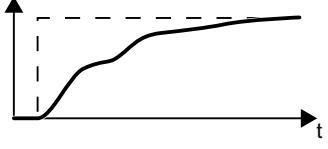
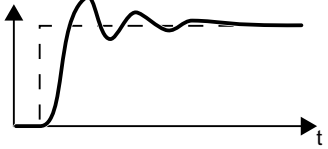
	<p>Optimum controller response for applications that do not permit any overshoot.</p> <p>The actual value approaches the setpoint without any significant overshoot.</p>
	<p>Optimum controller behavior for fast correction and quick compensation of disturbance components.</p> <p>The actual value approaches the setpoint and slightly overshoots, maximum 10 % of the setpoint step.</p>
	<p>The actual value only slowly approaches the setpoint.</p> <ul style="list-style-type: none"> <li>• Increase the proportional component <math>K_p</math> (p2280) and reduce the integration time <math>T_i</math> (p2285).</li> </ul>
	<p>The actual value only slowly approaches the setpoint with slight oscillation.</p> <ul style="list-style-type: none"> <li>• Increase the proportional component <math>K_p</math> (p2280) and reduce the rate time <math>T_d</math> (p2274)</li> </ul>
	<p>The actual value quickly approaches the setpoint, but overshoots too much.</p> <ul style="list-style-type: none"> <li>• Decrease the proportional component <math>K_p</math> (p2280) and increase the integration time <math>T_i</math> (p2285).</li> </ul>

3. Set the ramp-up and ramp-down times of the ramp-function generator back to their original value.

You have manually set the technology controller.

**Limiting the output of the technology controller**

In the factory setting, the output of the technology controller is limited to  $\pm$  maximum speed. You must change this limit, depending on your particular application.

Example: The output of the technology controller supplies the speed setpoint for a pump. The pump should only run in the positive direction.

Function diagrams

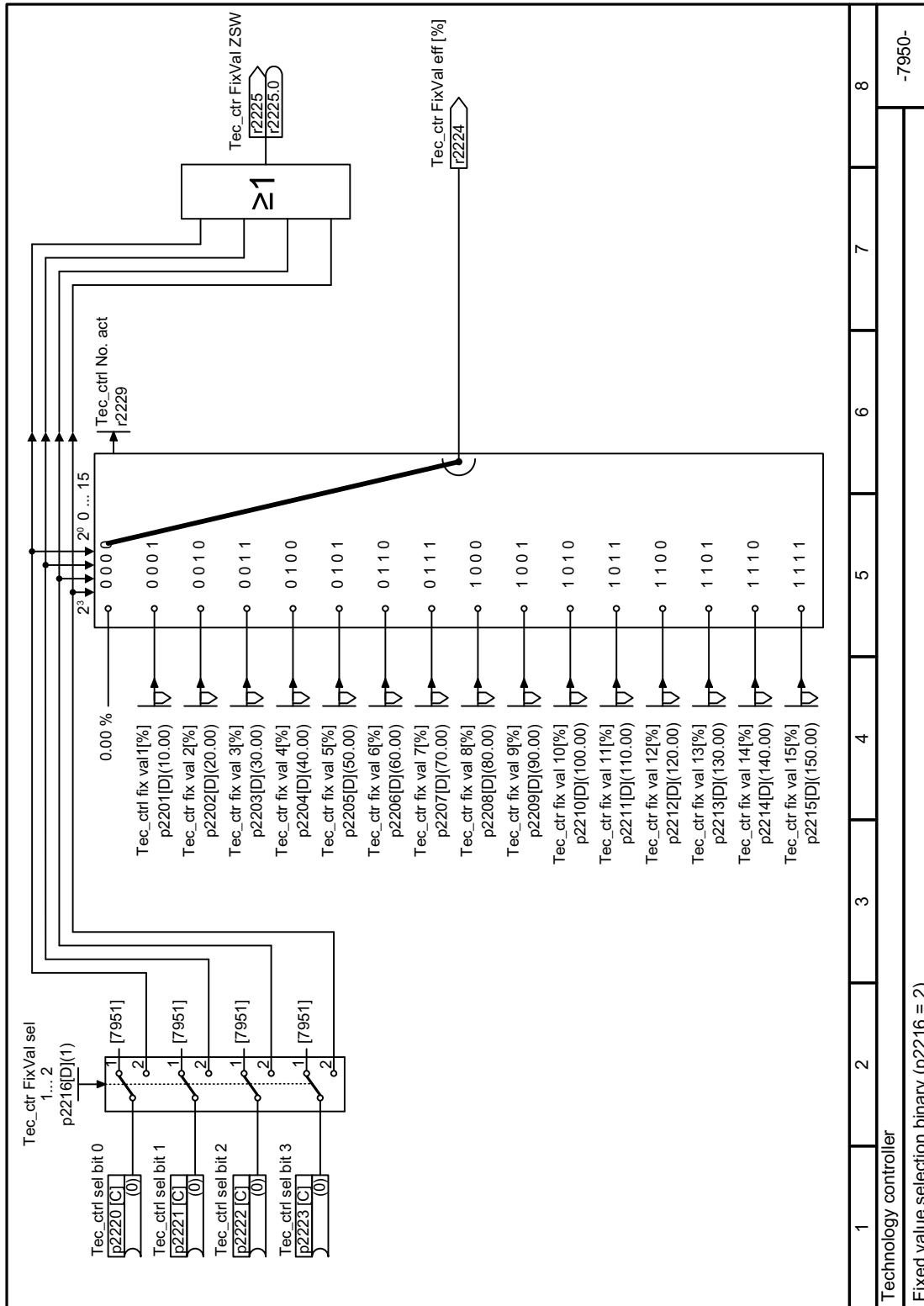

Figure 6-44 FP 7950

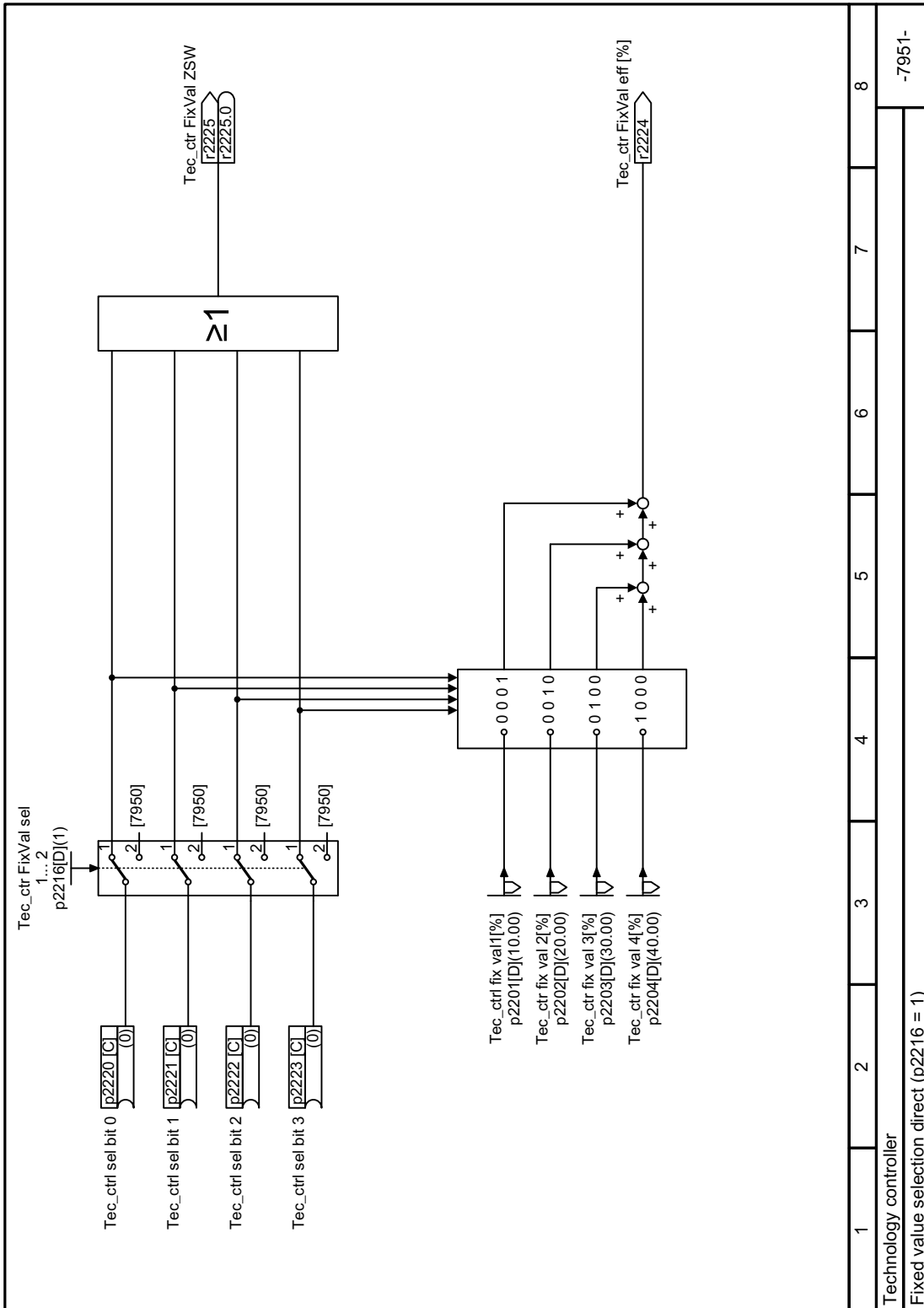

Figure 6-45 FP 7951

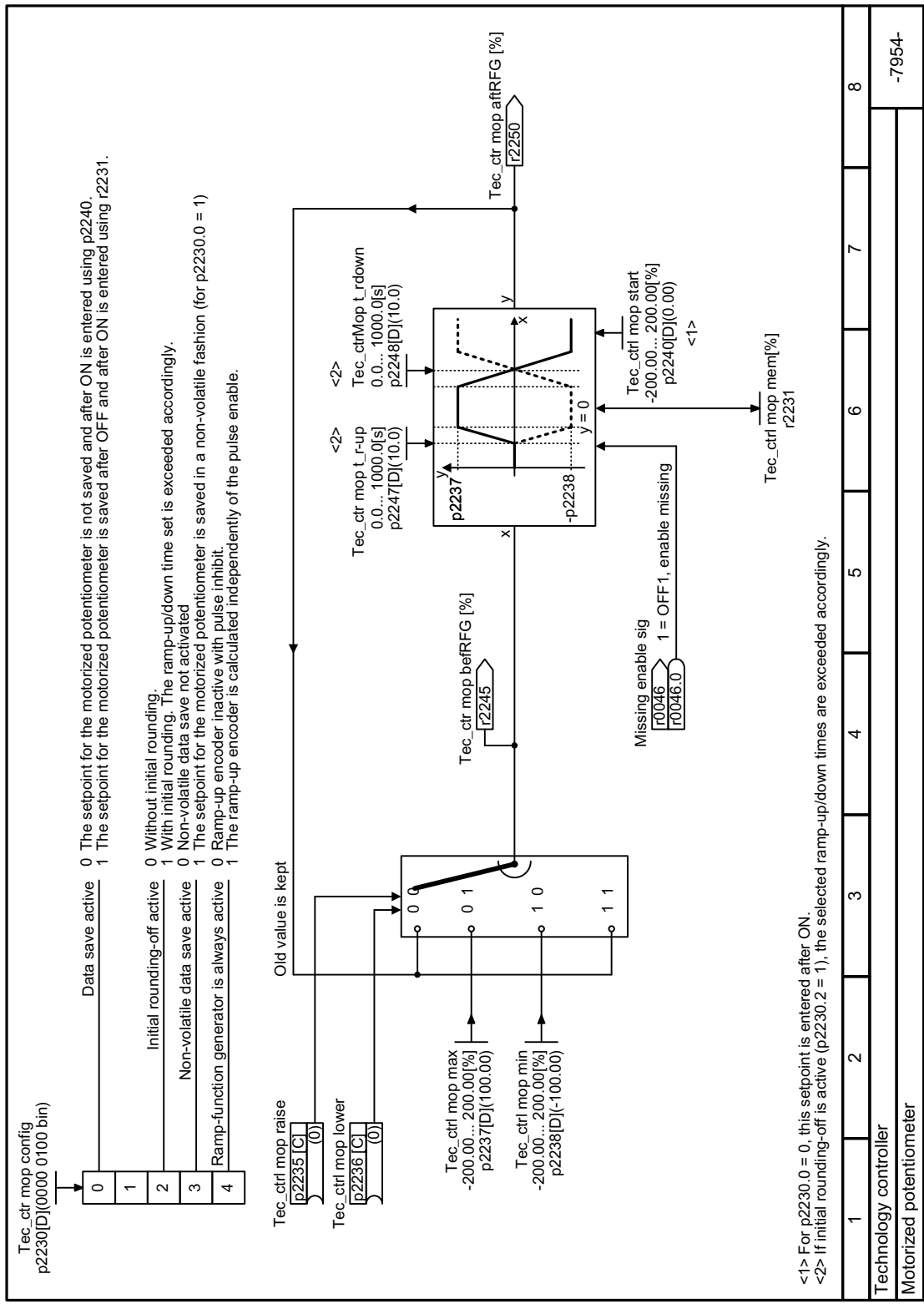

Figure 6-46 FP 7954



## Parameters

Table 6-52 Basic settings

Number	Name	Factory setting
r0046[0...31]	CO/BO: Missing enable signals	-
r0052[0...15]	CO/BO: Status word 1	-
r0056[0...15]	CO/BO: Status word, closed-loop control	-
r1084	CO: Speed limit positive active	-
r1087	CO: Speed limit negative active	- rpm
p2200[C]	BI: Technology controller enable	0
p2252	Technology controller configuration	See parameter list
p2253[C]	CI: Technology controller setpoint 1	0
p2254[C]	CI: Technology controller setpoint 2	0
p2255	Technology controller setpoint 1 scaling	100%
p2256	Technology controller setpoint 2 scaling	100%
p2257	Technology controller ramp-up time	1 s
p2258	Technology controller ramp-down time	1 s
r2260	CO: Technology controller setpoint after ramp-function generator	- %
p2261	Technology controller setpoint filter time constant	0 s
r2262	CO: Technology controller setpoint after filter	- %
p2263	Technology controller type	0
r2273	CO: Technology controller system deviation	- %
p2274	Technology controller differentiation time constant	0 s
p2280	Technology controller proportional gain	See parameter list
p2285	Technology controller integral time	See parameter list
p2286	BI: Hold technology controller integrator	56.13
p2289[C]	CI: Technology controller precontrol signal	0
p2306	Technology controller system deviation inversion	0
p2339	Technology controller threshold value for I proportion stop at skip speed	- s
r2344	CO: Technology controller last speed setpoint (smoothed)	- %
p2345	Technology controller fault response	0
r2349[0...13]	CO/BO: Technology controller status word	-
r3889[0...10]	CO/BO: ESM status word	-

Table 6-53 Limiting the output of the technology controller

Number	Name	Factory setting
p2290[C]	BI: Technology controller limitation enable	1
p2291	CO: Technology controller maximum limiting	100%
p2292	CO: Technology controller minimum limiting	0%
p2293	Technology controller ramp-up/ramp-down time	1 s

Number	Name	Factory setting
r2294	CO: Technology controller output signal	- %
p2295	CO: Technology controller output scaling	100%
p2296[C]	CI: Technology controller output scaling	2295
p2297[C]	CI: Technology controller maximum limiting signal source	1084
p2298[C]	CI: Technology controller minimum limiting signal source	1087
p2299[C]	CI: Technology controller limitation offset	0
p2302	Technology controller output signal start value	0%

Table 6-54 Adapting the actual value of the technology controller

Number	Name	Factory setting
p2264[C]	CI: Technology controller actual value	0
p2265	Technology controller actual value filter time constant	0 s
p2266	CO: Technology controller actual value after filter	- %
p2267	Technology controller upper limit actual value	100%
p2268	Technology controller lower limit actual value	-100 %
p2269	Technology controller gain actual value	100%
p2270	Technology controller actual value function	0
p2271	Technology controller actual value inversion	0
r2272	CO: Technology controller actual value scaled	- %

Table 6-55 PID technology controller, fixed values (binary selection)

Number	Name	Factory setting
p2201[D]	CO: Technology controller fixed value 1	10 %
p2202[D]	CO: Technology controller fixed value 2	20%
p2203[D]	CO: Technology controller fixed value 3	30%
p2204[D]	CO: Technology controller fixed value 4	40%
p2205[D]	CO: Technology controller fixed value 5	50%
p2206[D]	CO: Technology controller fixed value 6	60%
p2207[D]	CO: Technology controller fixed value 7	70%
p2208[D]	CO: Technology controller fixed value 8	80%
p2209[D]	CO: Technology controller fixed value 9	90%
p2210[D]	CO: Technology controller fixed value 10	100%
p2211[D]	CO: Technology controller fixed value 11	110 %
p2212[D]	CO: Technology controller fixed value 12	120 %
p2213[D]	CO: Technology controller fixed value 13	130 %
p2214[D]	CO: Technology controller fixed value 14	140 %
p2215[D]	CO: Technology controller fixed value 15	150 %
p2216[D]	Technology controller fixed value selection method	1
r2224	CO: Technology controller fixed value active	- %

Number	Name	Factory setting
r2225	CO/BO: Technology controller fixed value selection status word	- %
r2229	Technology controller number actual	-

Table 6-56 PID technology controller, fixed values (direct selection)

Number	Name	Factory setting
p2216[D]	Technology controller fixed value selection method	1
p2220[C]	BI: Technology controller fixed value selection bit 0	0
p2221[C]	BI: Technology controller fixed value selection bit 1	0
p2222[C]	BI: Technology controller fixed value selection bit 2	0
p2223[C]	BI: Technology controller fixed value selection bit 3	0
r2224	CO: Technology controller fixed value active	- %
r2225	CO/BO: Technology controller fixed value selection status word	- %
r2229	Technology controller number actual	-

Table 6-57 PID technology controller, motorized potentiometer

Number	Name	Factory setting
r2231	Technology controller motorized potentiometer setpoint memory	- %
p2235[C]	BI: Technology controller motorized potentiometer, setpoint, raise	0
p2236[C]	BI: Technology controller motorized potentiometer, setpoint, lower	0
p2237[D]	Technology controller motorized potentiometer maximum value	100%
p2238[D]	Technology controller motorized potentiometer minimum value	-100 %
p2240[D]	Technology controller motorized potentiometer start value	0%
r2245	CO: Technology controller motorized potentiometer, setpoint before RFG	- %
p2247[D]	Technology controller motorized potentiometer ramp-up time	10 s
p2248[D]	Technology controller motorized potentiometer ramp-down time	10 s
r2250	CO: Technology controller motorized potentiometer, setpoint after RFG	- %

## Further information

You will find additional information on the following PID controller components in the Internet at:

- Setpoint input: Analog value or fixed setpoint
- Setpoint channel: Scaling, ramp-function generator and filter



- Actual value channel: Filter, limiting and signal processing
  - PID controller: Principle of operation of the D component, inhibiting the I component and the control sense
  - Enable, limiting the controller output and fault response
-  FAQ (<http://support.automation.siemens.com/WW/view/en/92556266>)

### 6.5.1.1 Autotuning the PID technology controller

#### Overview

Autotuning is a converter function for the automatic optimization of the PID technology controller.

#### Precondition

##### Additional functions

- The motor closed-loop control is set
- The PID technology controller must be set the same as when used in subsequent operation:
  - The actual value is interconnected.
  - Scalings, filter and ramp-function generator have been set.
  - The PID technology controller is enabled (p2200 = 1 signal).

##### Tools

One of the commissioning tools is needed to change the function settings.

#### Function description

For active autotuning, the converter interrupts the connection between the PID technology controller and the speed controller. Instead of the PID technology controller output, the autotuning function specifies the speed setpoint.

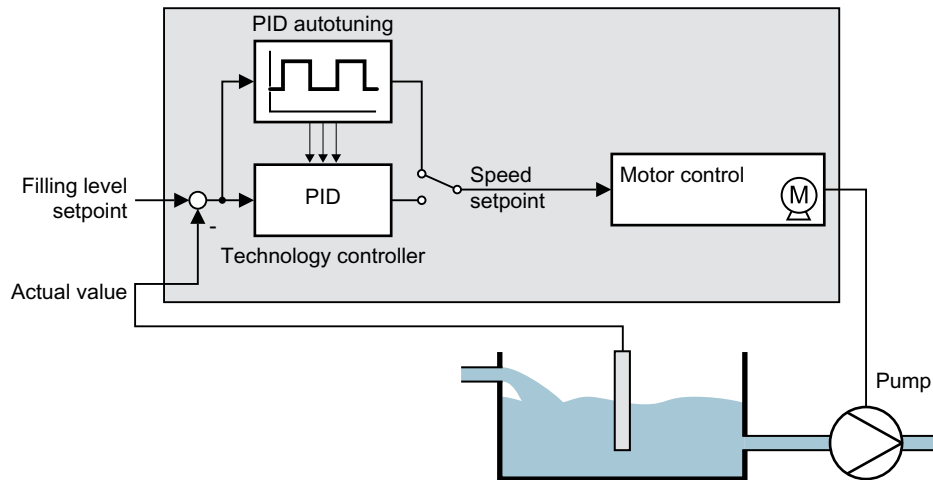

Figure 6-48 Autotuning using closed-loop level control as example

The speed setpoint results from the technology setpoint and a superimposed rectangular signal with amplitude p2355. If actual value = technology setpoint  $\pm$  p2355, the autotuning function switches the polarity of the superimposed signal. This causes the converter to excite the process variable for an oscillation.

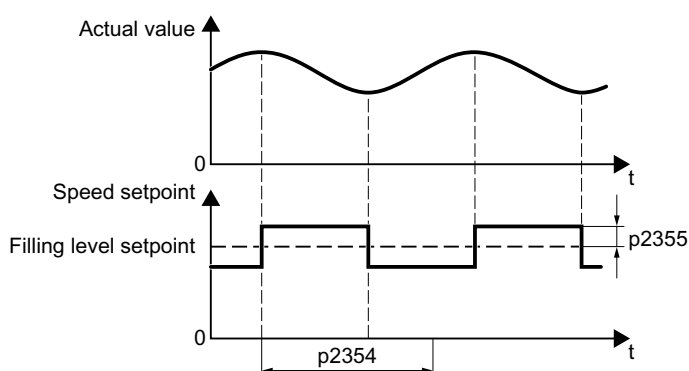

Figure 6-49 Example for speed setpoint and actual process value for autotuning

The converter calculates the parameters of the PID controller from the determined oscillation frequency.

### Executing autotuning



1. Select with p2350 the appropriate controller setting.
2. Switch on the motor.  
The converter signals Alarm A07444.
3. Wait until alarm A07444 goes away.  
The converter has recalculated parameters p2280, p2274 and p2285.  
If the converter signals fault F07445:
  - If possible, double p2354 and p2355.
  - Repeat the autotuning with the changed parameters.
4. Back up the calculated values so that they are protected against power failure, e.g. using the BOP-2: OPTIONS → RAM-ROM.

You have auto tuned the PID controller.

□

## Parameters

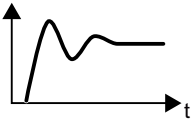
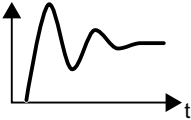
Number	Name	Factory setting
p2274	Technology controller differentiation time constant	0.0 s
p2280	Technology controller proportional gain	See parameter list
p2285	Technology controller integral time	See parameter list

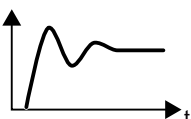
Number	Name	Factory setting
p2350	<p>Enable PID autotuning</p> <p>Automatic controller setting based on the "Ziegler Nichols" method.</p> <p>After completion of the autotuning, the converter sets p2350 = 0.</p> <p>0: No function</p> <p>1: The process variable follows the setpoint after a sudden setpoint change (step function) relatively quickly, however with an overshoot.</p>  <p>2: Faster controller setting than for p2350 = 1 with larger overshoot of the controlled variable.</p>  <p>3: Slower controller setting than for p2350 = 1. Overshoot of the controlled variable is, to a large extent, avoided.</p>  <p>4: Controller setting after completion of the autotuning as for p2350 = 1. Optimize only the P and I action of the PID controller.</p> 	0
p2354	PID autotuning monitoring time	240 s
p2355	PID autotuning offset	5%

### 6.5.1.2 Adapting Kp and Tn

#### Overview

The function adapts the PID technology controller to the process, e.g. depending on the system deviation.

#### Function description

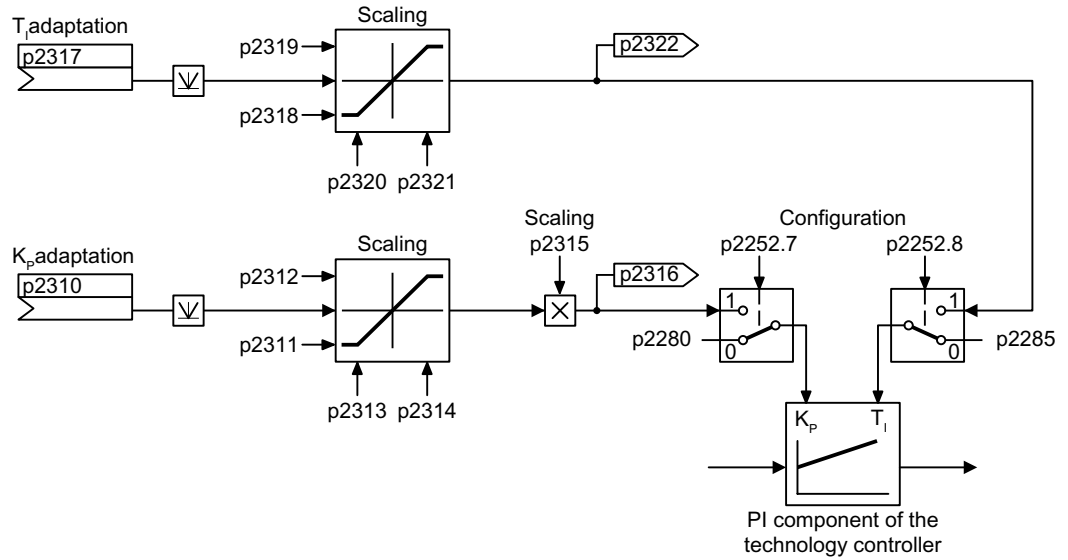

Figure 6-50 Controller adaptation

Function diagram

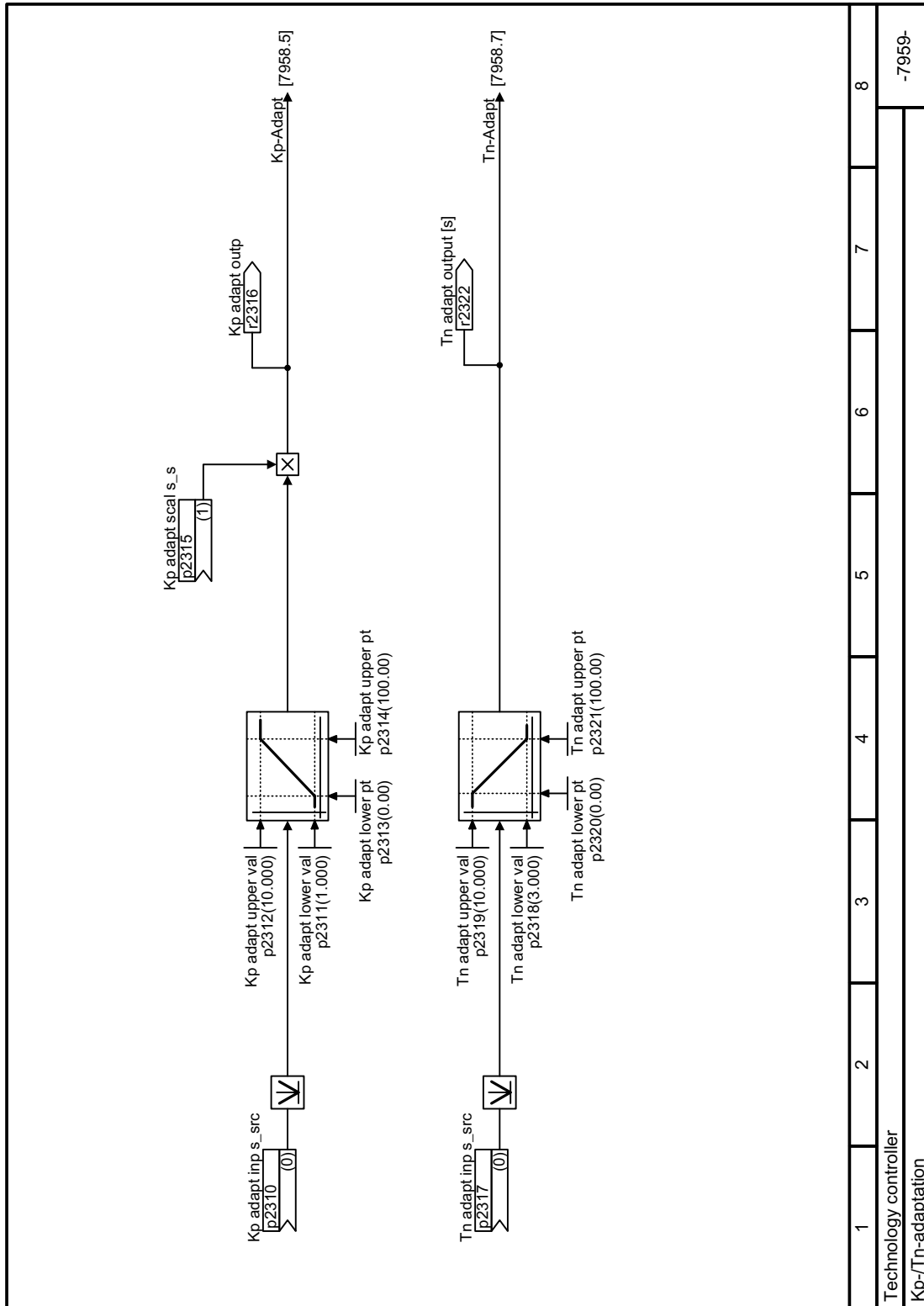

Figure 6-51 FP 7959

## Parameters

Number	Name	Factory setting
p2252	Technology controller configuration	0000 0000 0000 0000 bin
p2280	Technology controller proportional gain	1
p2285	Technology controller integral time	30 s
p2310	CI: Technology controller Kp adaptation input value signal source	0
p2311	Technology controller, lower Kp adaptation value	1
p2312	Technology controller, upper Kp adaptation value	10
p2313	Technology controller lower Kp adaptation transition point	0%
p2314	Technology controller upper Kp adaptation transition point	100%
p2315	CI: Technology controller Kp adaptation scaling signal source	1
r2316	CO: Technology controller Kp adaptation output	-
p2317	CI: Technology controller Tn adaptation input value signal source	0
p2318	Technology controller, lower Tn adaptation value	3 s
p2319	Technology controller, upper Tn adaptation value	10 s
p2320	Technology controller lower Tn adaptation transition point	0%
p2321	Technology controller upper Tn adaptation transition point	100%
r2322	CO: Technology controller Tn adaptation output	- s

### 6.5.2 Free technology controllers

#### Overview



The converter has three additional technology controllers.

The three "free technology controllers" have fewer setting options compared with the PID technology controller described above.



PID technology controller (Page 269)

#### Function description

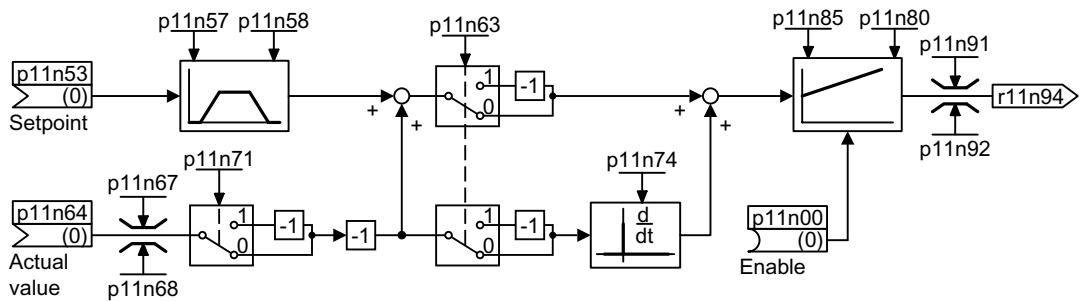

- n = 0 Free technology controller 0
- n = 1 Free technology controller 1
- n = 2 Free technology controller 2

Figure 6-52 Simplified function chart of the additional PID technology controllers, n = 0 ... 2

The additional technology controllers allow several process variables to be simultaneously controlled using one converter.

#### Example

An HVAC system with heating and cooling valves to process the air:

- The main controller controls the speed of the fan drive.
- The additional technology controllers control the cooling and heating via the two analog outputs.

#### Parameters

Table 6-58 Parameters for the free technology controller 0

Number	Name	Factory setting
p11000	BI: Free tec_ctrl 0 enable	0
p11026	Free tec_ctrl 0 unit selection	1 (%)
p11027	Free tec_ctrl 0 unit reference variable	1.00
p11028	Free tec_ctrl 0 sampling time	2 (256 ms)
r11049.0...11	CO/BO: Free tec_ctrl 0 status word	-



Number	Name	Factory setting
p11053	CI: Free tec_ctrl 0 setpoint signal source	0
p11057	Free tec_ctrl 0 setpoint ramp-up time	1 s
p11058	Free tec_ctrl 0 setpoint ramp-down time	1 s
p11063	Free tec_ctrl 0 error signal inversion	0
p11064	CI: Free tec_ctrl 0 actual value signal source	0
p11065	Free tec_ctrl 0 actual value smoothing time constant	0 s
p11067	Free tec_ctrl 0 actual value upper limit	100%
p11068	Free tec_ctrl 0 actual value lower limit	-100 %
p11071	Free tec_ctrl 0 actual value inversion	0
r11072	CO: Free tec_ctrl 0 actual value after limiter	-
r11073	CO: Free tec_ctrl 0 control deviation	-
p11074	Free tec_ctrl 0 differentiation time constant ( $T_d$ )	0 s
p11080	Free tec_ctrl 0 proportional gain ( $K_p$ )	1
p11085	Free tec_ctrl 0 integral time ( $T_i$ )	30 s
p11091	CO: Free tec_ctrl 0 maximum limit	100%
p11092	CO: Free tec_ctrl 0 minimum limit	0%
p11093	Free tec_ctrl 0 ramp-up/ramp-down time limit	1 s
r11094	CO: Free tec_ctrl 0 output signal	-
p11097	CI: Free tec_ctrl 0 maximum limit signal source	11091[0]
p11098	CI: Free tec_ctrl 0 minimum limit signal source	11092[0]
p11099	CI: Free tec_ctrl 0 offset limit signal source	0

Further information is provided in the parameter list.

 Parameters (Page 373)

### 6.5.3 Cascade control

#### Overview



The cascade control is ideal for applications in which, for example, significantly fluctuating pressures or flow rates are equalized.

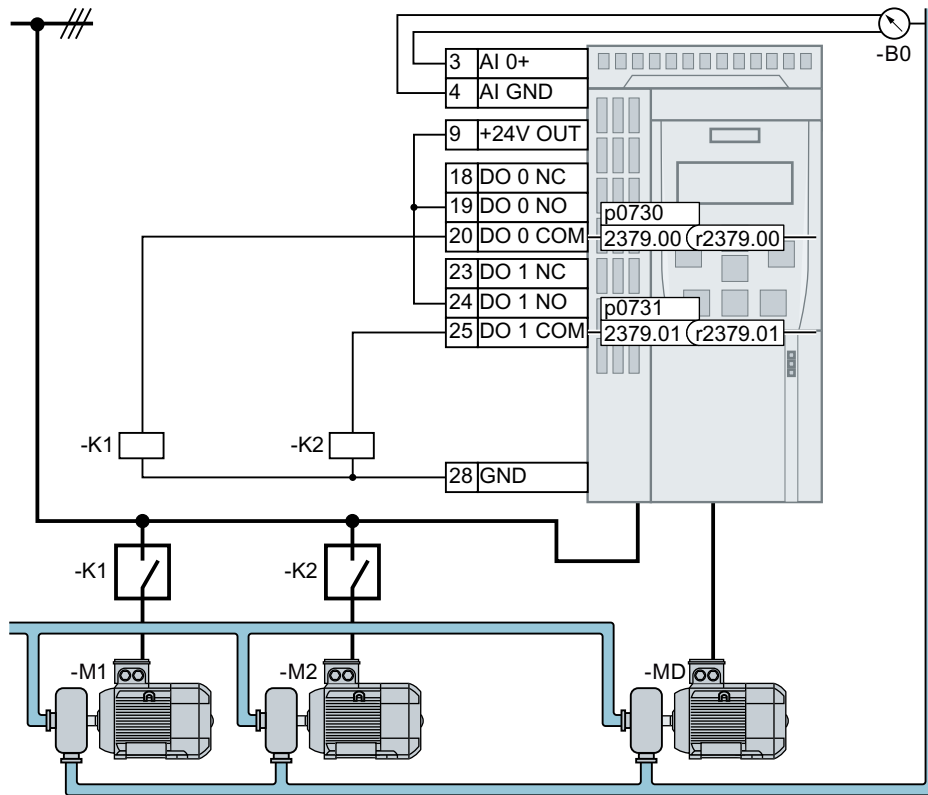

M<sub>D</sub> Speed-controlled motor

M<sub>1</sub> ... M<sub>2</sub> Uncontrolled motors

B<sub>0</sub> Pressure sensor. Interconnect the signal of the pressure sensor with the actual-value input of the technology controller.

Figure 6-53 Example: Cascade control for the pressure in a liquid pipe

Depending on the set-actual variance of the technology controller, the cascade control of the converter switches a maximum of three additional motors directly to the line supply via contactors.

**Precondition**

To deploy the cascade control, you must activate the technology controller.

## Function description

### Activate uncontrolled motors $M_1 \dots M_2$

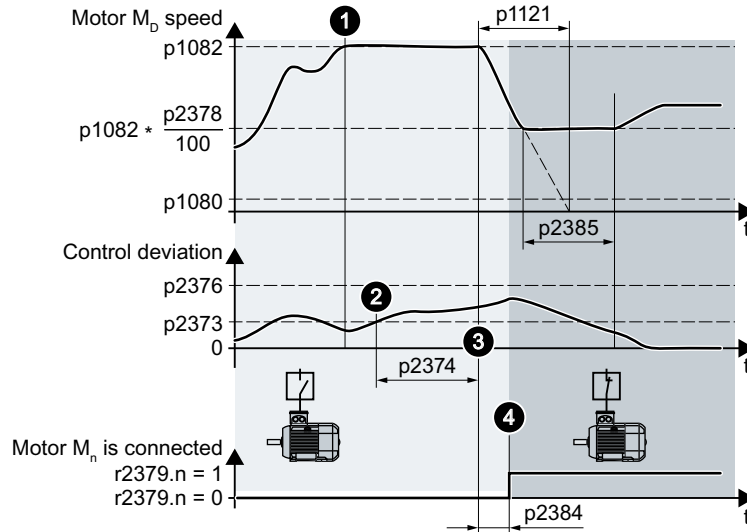

Figure 6-54 Activate uncontrolled motors  $M_1 \dots M_2$

Procedure for connecting an uncontrolled motor:

1. The speed-controlled motor turns with maximum speed  $p1082$ .
2. The control deviation of the technology controller is greater than  $p2373$ .
3. Time  $p2374$  has expired.  
The converter brakes the speed-controlled motor with ramp-down time  $p1121$  to the activation/deactivation speed  $p2378$ . Until the activation/deactivation speed  $p2378$  is attained, the converter deactivates the technology controller temporarily.
4. After switch-on delay  $p2384$ , the converter connects an uncontrolled motor.

### Deactivate uncontrolled motors $M_1 \dots M_2$

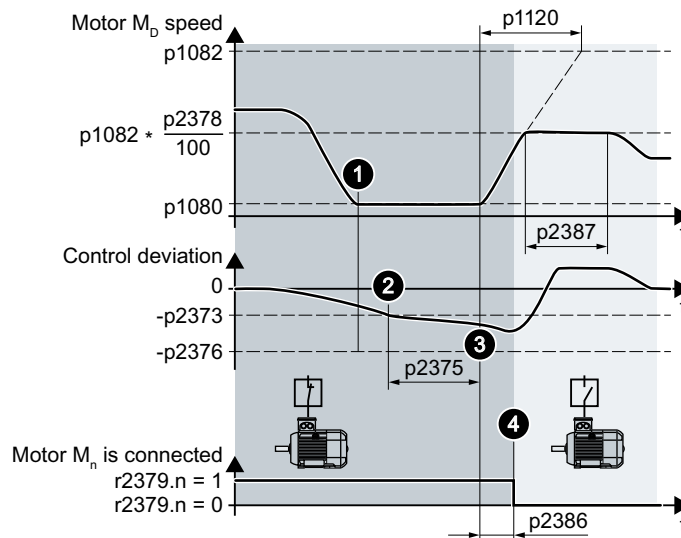

Figure 6-55 Deactivate uncontrolled motors  $M_1 \dots M_2$

Procedure for switching off an uncontrolled motor:

1. The speed-controlled motor turns with minimum speed p1080.
2. The control deviation of the technology controller is less than -p2373.
3. Time p2375 has expired.  
The converter accelerates the speed-controlled motor with ramp-up time p1120 to the activation/deactivation speed p2378. Until the activation/deactivation speed p2378 is attained, the converter deactivates the technology controller temporarily.
4. After shutdown delay p2386, the converter disconnects an uncontrolled motor.

**Sequence for activating and deactivating the  $M_1 \dots M_2$  motors**

Table 6-59 p2371 specifies the sequence for activating and deactivating the motors

p2371	→ → → Sequence for activating motors → → →			Power of the activated $M_1 \dots M_3$ motors compared with the speed-controlled DM motor	
	→ → → Sequence for deactivating motors → → →				
	Stage 1	Stage 2	Stage 3	$1 \times M_D$	$2 \times M_D$
1	$M_1$			$M_1$	---
2	$M_1$	$M_1+M_2$		$M_1, M_2$	---
3	$M_1$	$M_2$	$M_1+M_2$	$M_1$	$M_2$

**Parameter**

Number	Name	Factory setting
p2200	Technology controller enable	0
p2251	Technology controller mode	0
p2370	Cascade control enable	0
p2371	Cascade control configuration	0
p2372	Cascade control motor selection mode	0
p2373	Cascade control activation threshold	20%
p2374	Cascade control activation delay	30 s
p2375	Cascade control deactivation delay	30 s
p2376	Cascade control overload threshold	25%
p2377	Cascade control interlock time	0 s
p2378	Cascade control activation/deactivation speed	50%
r2379	Cascade control status word	---
p2380	Cascade control operating hours	0 h
p2381	Cascade control maximum time for continuous mode	24 h
p2382	Cascade control absolute operating time limit	24 h
p2383	Cascade control deactivation sequence	0
p2384	Cascade control motor switch-on delay	0 s
p2385	Cascade control stop time activation speed	0 s
p2386	Cascade control motor switch-off delay	0 s
p2387	Cascade control stop time deactivation speed	0 s

Additional information is provided in the parameter list and in function diagram 7036.

## More information

### Interaction with the "Hibernation mode" function

In order that the "Cascade control" and "Hibernation mode" functions do not influence each other, you must make the following settings in the cascade control:

- $p2392 < p2373$   
The restart value of the hibernation mode  $p2392$  must be lower than the activation threshold for the cascade control  $p2373$ .
- $p2373 < p2376$   
The activation threshold for the cascade control  $p2373$  must be lower than the overload threshold for the cascade control  $p2376$ .
- It is not permissible for the main drive to be in the hibernation mode.
- The actual speed must be higher than the restart speed for hibernation mode  $(p1080 + p2390) \times 1.05$ .
- The value for the activation delay of the cascade control  $p2374$  must be higher than the ramp-up time  $t_y$  from hibernation mode.  
 $t_y = (p1080 + p2390) \times 1.05 \times p1120 \times p1139/p1082$

### 6.5.4 Real time clock (RTC)



The real-time clock is the basis for time-dependent process controls, e.g.:

- To reduce the temperature of a heating control during the night
- To increase the pressure of a water supply at certain times during the day

#### Accept the real-time clock in the alarm and fault buffer

Using the real-time clock, you can track the sequence of alarms and faults over time. When an appropriate message occurs, the converter converts the real-time clock into the UTC time format (Universal Time Coordinated):

Date, time  $\Rightarrow$  01.01.1970, 0:00 + d (days) + m (milliseconds)

The converter takes the number "d" of the days and the number "m" of the milliseconds in the alarm and fault times of the alarm and/or fault buffer.



Warnings, faults and system messages (Page 777)

#### Converting UTC to RTC

An RTC can again be calculated in the UTC format from the saved fault or alarm time. In the Internet, you will find programs to convert from UTC to RTC, e.g.



UTC to RTC (<http://unixtime-converter.com/>)

#### Example:

Saved as alarm time in the alarm buffer:

r2123[0] = 2345 [ms]  
r2145[0] = 14580 [days]

Number of seconds =  $2345 / 1000 + 14580 \times 86400 = 1259712002$

Converting this number of seconds to RTC provides the date: 02.12.2009, 01:00:02.

The times specified for alarms and faults always refer to standard time.

#### Function and settings

The real-time clock starts as soon as the Control Unit power supply is switched on for the first time. The real-time clock comprises the time in a 24 hour format and the date in the "day, month, year" format.

After a Control Unit power supply interruption, the real-time clock continues to run for approx. five days.

If you wish to use the real-time clock, you must set the time and date once when commissioning.

If you restore the converter factory setting, the converter only resets parameters p8402 and p8405 of the real-time clock. P8400 and p8401 are not reset.

## Parameters

Number	Name	Factory setting
p8400[0 ... 2]	RTC time	0
p8401[0 ... 2]	RTC date	1.1.1970
p8402[0 ... 8]	RTC daylight saving time setting	0
r8403	RTC daylight saving time actual difference	-
r8404	RTC weekday	-
p8405	Activate/deactivate RTC alarm A01098	1

### 6.5.5 Time switch (DTC)



The "time switch" (DTC) function, along with the real-time clock in the converter, offers the option of controlling when signals are switched on and off.

**Examples:**

- Switching temperature control from day to night mode.
- Switching a process control from weekday to weekend.

#### Principle of operation of the time switch (DTC)

The converter has three independently adjustable time switches. The time switch output can be interconnected with every binector input of your converter, e.g. with a digital output or a technology controller's enable signal.

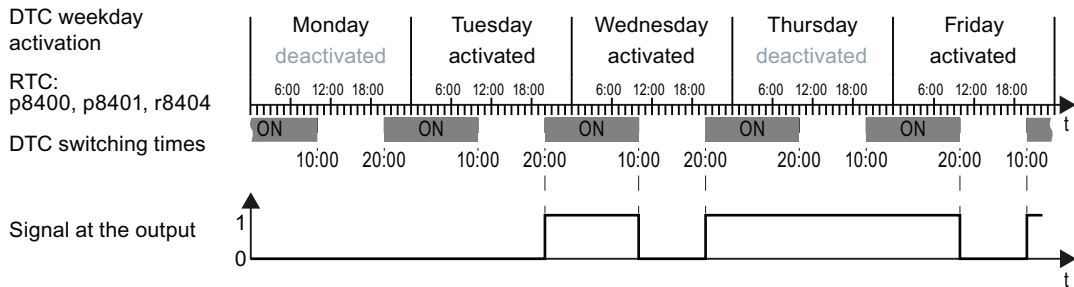

Figure 6-56 Example of the response of the time switch.

#### Settings for the example with DTC1

- Enable parameterization of the DTC: p8409 = 0.  
As long as the parameterization of the DTC is enabled, the converter holds the output of all three DTC (r84x3, x = 1, 2, 3; r84x3.0 normal, r84x3.1 inverted status message) at LOW.
- Activate/deactivate the weekday
  - p8410[0] = 0 Monday
  - p8410[1] = 1 Tuesday
  - p8410[2] = 1 Wednesday
  - p8410[3] = 0 Thursday
  - p8410[4] = 1 Friday
  - p8410[5] = 1 Saturday
  - p8410[6] = 0 Sunday
- Setting switching times:
  - ON: p8411[0] = 20 (hh), p8411[1] = 0 (MM)
  - OFF: p8412[0] = 10 (hh), p8412[1] = 0 (MM)
- Enable the setting: p8409 = 1.  
The converter re-enables the DTC output.

Further information is provided in the parameter list.



## 6.6 Motor control

### Overview



The converter has two alternative methods to ensure the motor speed follows the configured speed setpoint:

- U/f control
- Vector control

### 6.6.1 Reactor, filter and cable resistance at the converter output

#### Overview

Components between the converter and the motor influence the closed-loop control quality of the converter:

- Output reactor  
In the factory setting, the converter assumes for the motor data identification that no output reactor is connected at the converter output.
- Motor cable with unusually high cable resistance.  
For the motor data identification, the converter assumes a cable resistance = 20 % of the stator resistance of the cold motor.

#### Function description

You must correctly set the components between the converter and motor to achieve an optimum closed-loop control quality

##### Procedure

1. Set p0010 = 2.
2. Set the cable resistance in p0352.
3. Set p0230 to the appropriate value.
4. Set p0235 to the appropriate value.
5. Set p0010 = 0.
6. Carry out the quick commissioning and the motor identification again.  
 Quick commissioning using the BOP-2 operator panel (Page 131)  
You have set the reactor, filter and cable resistance between the converter and motor.

Parameters

Number	Name	Factory setting
p0010	Drive commissioning parameter filter	1
p0230	Drive filter type, motor side	0
p0235	Number of motor reactors in series	1
p0350[M]	Motor stator resistance, cold	0 Ω
p0352[M]	Cable resistance	0 Ω

For additional information on parameters, please refer to the parameter list.

6.6.2 V/f control

6.6.2.1 U/f control

Overview

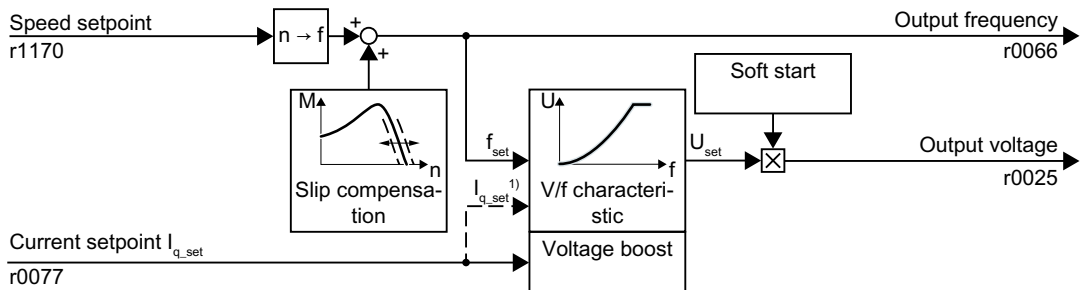

1) In the "Flux Current Control (FCC)" U/f version, the converter controls the motor current (starting current) at low speeds.

Figure 6-57 Simplified function diagram of the U/f control

The U/f control is a speed feedforward control with the following properties:

- The converter sets the output voltage on the basis of the U/f characteristic.
- The output frequency is essentially calculated from the speed setpoint and the number of pole pairs of the motor.
- The slip compensation corrects the output frequency depending on the load and thus increases the speed accuracy.
- The omission of a control loop means that the U/f control is stable in all cases.
- In applications with higher speed accuracy requirements, a load-dependent voltage boost can be selected (flux current control, FCC)

For operation of the motor with U/f control, you must set at least the following subfunctions appropriate for your application:

- V/f characteristic
- Voltage boost

## Function description

The converter has different U/f characteristics.

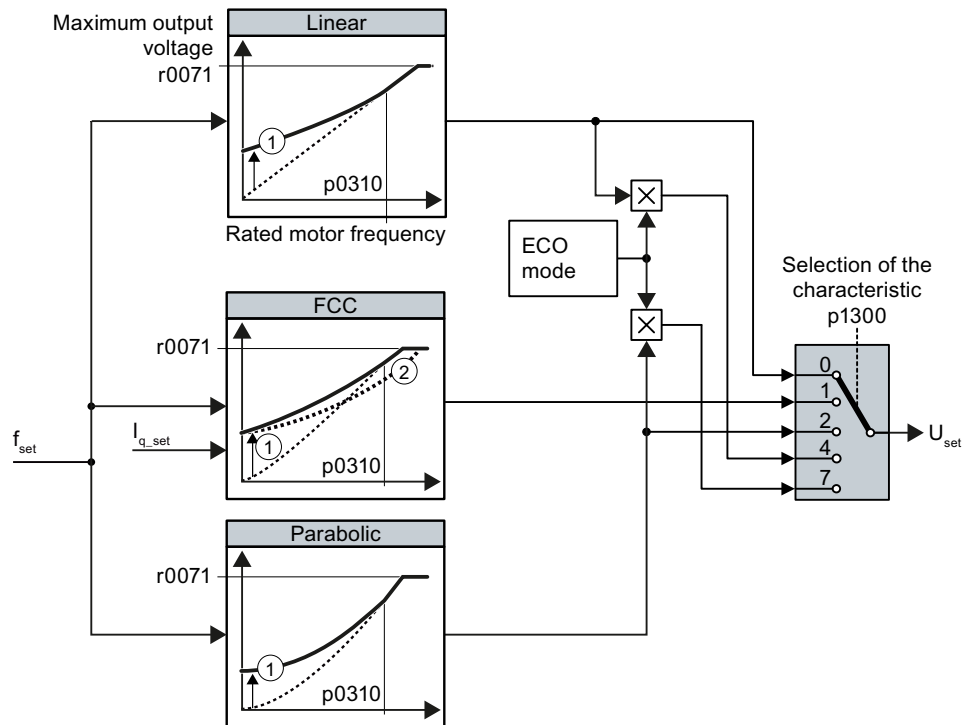

- ① The voltage boost of the characteristic optimizes motor start-up
- ② With flux current control (FCC), the converter compensates the voltage drop across the stator resistance of the motor

Figure 6-58 U/f characteristics of the converter

With increasing speed or output frequency, the converter increases its output voltage  $U$ . The maximum possible output voltage of the converter depends on the line voltage.

The converter can increase the output frequency even at the maximum output voltage. The motor is then operated with field weakening.

The value of the output voltage at the rated motor frequency also depends on the following variables:

The value of the output voltage at the rated motor frequency  $p0310$  also depends on the following variables:

- Ratio between the converter size and the motor size
- Line voltage
- Line impedance
- Actual motor torque

The maximum possible output voltage as a function of the input voltage is stated in the technical data.

 General converter technical data (Page 900)

Table 6-60 Linear and parabolic characteristics

Requirement	Application examples	Remark	Characteristic	Parameter
The required torque is independent of the speed	Eccentric-worm pump, compressor	-	Linear	p1300 = 0
		The converter compensates for the voltage drops across the stator resistance. Recommended for motors of less than 7.5 kW. Precondition: The motor data has been set according to the rating plate and the motor has been identified after the basic commissioning.	Linear with Flux Current Control (FCC)	p1300 = 1
The required torque increases with the speed	Centrifugal pumps, radial fans, axial fans, compressors	Lower losses in the motor and converter than with the linear characteristic.	Parabolic	p1300 = 2

Table 6-61 Characteristics for special applications

Requirement	Application examples	Remark	Characteristic	Parameter
Applications with a low dynamic response and constant speed	Centrifugal pumps, radial fans, axial fans	The ECO mode saves more energy than the parabolic characteristic. If the speed setpoint is reached and remains unchanged for 5 seconds, the converter reduces its output voltage again.	ECO mode	p1300 = 4 (linear characteristic ECO) or p1300 = 7 (parabolic characteristic ECO)

Function diagram

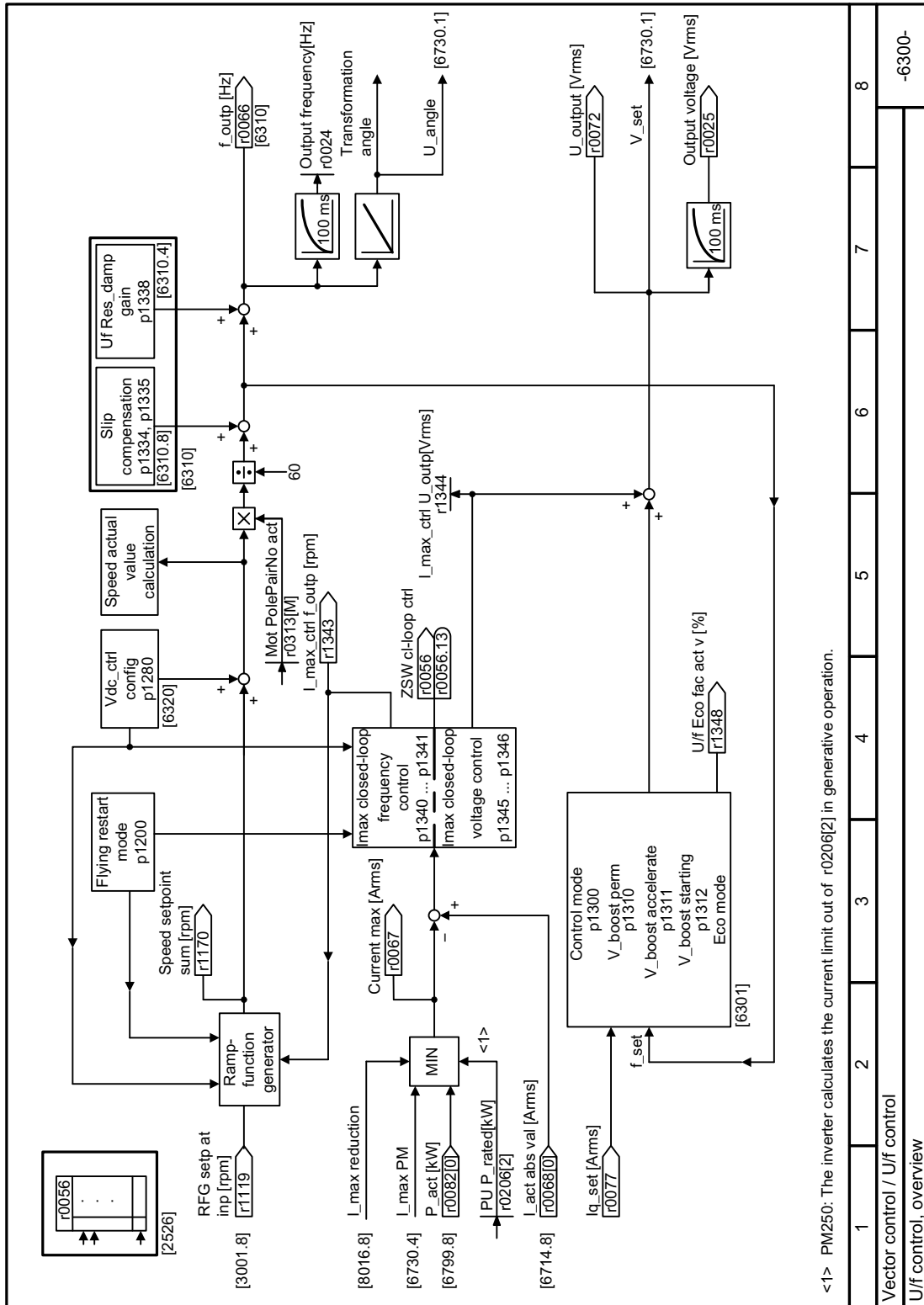

Figure 6-59 FP 6300

**Parameters**

Number	Name	Factory setting
r0025	CO: Output voltage, smoothed	- Vrms
r0066	CO: Output frequency	- Hz
r0071	Output voltage, maximum	- Vrms
p0304[M]	Rated motor voltage	0 Vrms
p0310[M]	Rated motor frequency	0 Hz
p1300[D]	Open-loop/closed-loop control operating mode	See parameter list
p1333[D]	U/f control FCC starting frequency	0 Hz
p1334[D]	U/f control slip compensation starting frequency	0 Hz
p1335[D]	Slip compensation scaling	0%
p1338[D]	U/f mode resonance damping gain	0

## 6.6.2.2 Optimizing motor starting

### Overview

After selection of the U/f characteristic, no further settings are required in most applications. In the following circumstances, the motor cannot accelerate to its speed setpoint after it has been switched on:

- Load moment of inertia too high
- Load torque too large
- Ramp-up time p1120 too short

To improve the starting behavior of the motor, a voltage boost can be set for the U/f characteristic at low speeds.

### Precondition

The ramp-up time of the ramp-function generator is, depending on the motor rated power, 1 s (< 1 kW) ... 10 s (> 10 kW).

### Function description

#### Setting the voltage boost for U/f control

The converter boosts the voltage corresponding to the starting currents p1310 ... p1312.

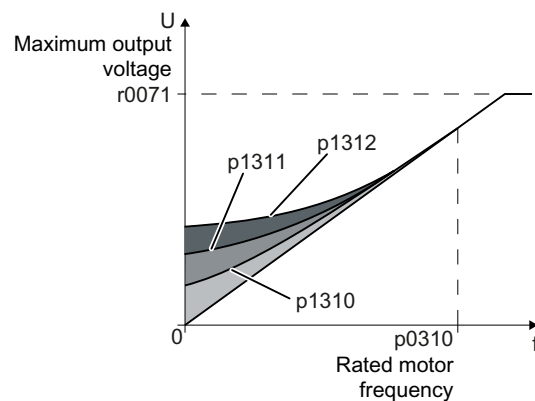

Figure 6-60 The resulting voltage boost using a linear characteristic as example

Increase parameter values p1310 ... p1312 in steps of  $\leq 5\%$ . Excessively high values in p1310 ... p1312 can cause the motor to overheat and switch off (trip) the converter due to overcurrent.

If message A07409 appears, it is not permissible that you further increase the value of any of the parameters.

#### Procedure

1. Switch on the motor with a setpoint of a few revolutions per minute.
2. Check whether the motor rotates smoothly.

*6.6 Motor control*

3. If the motor does not rotate smoothly, or even remains stationary, increase the voltage boost p1310 until the motor runs smoothly.
4. Accelerate the motor to the maximum speed with maximum load.
5. Check that the motor follows the setpoint.
6. If necessary, increase the voltage boost p1311 until the motor accelerates without problem.

In applications with a high break loose torque, you must also increase parameter p1312 in order to achieve a satisfactory motor response.

You have set the voltage boost.





Function diagrams

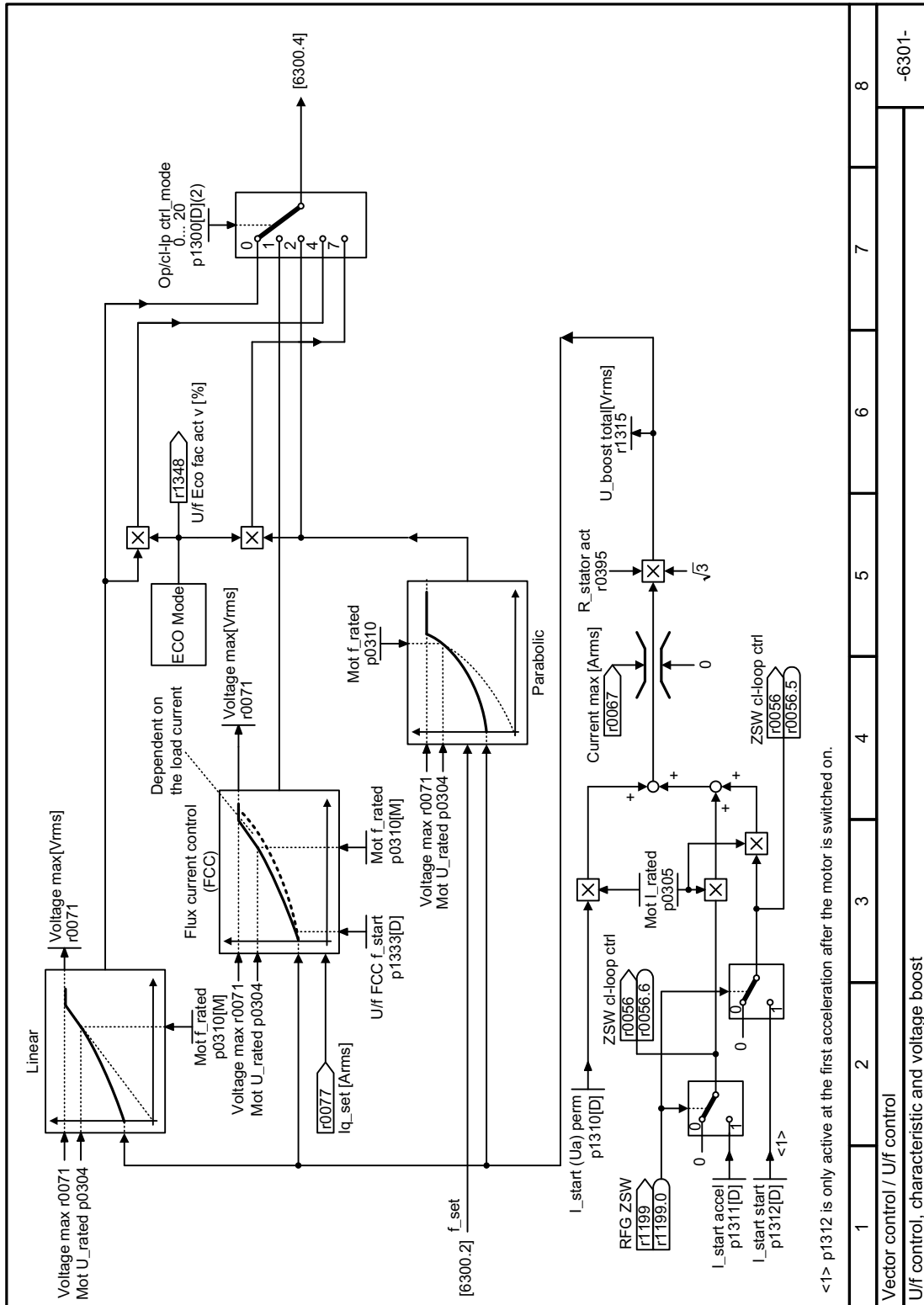

Figure 6-61 FP 6301

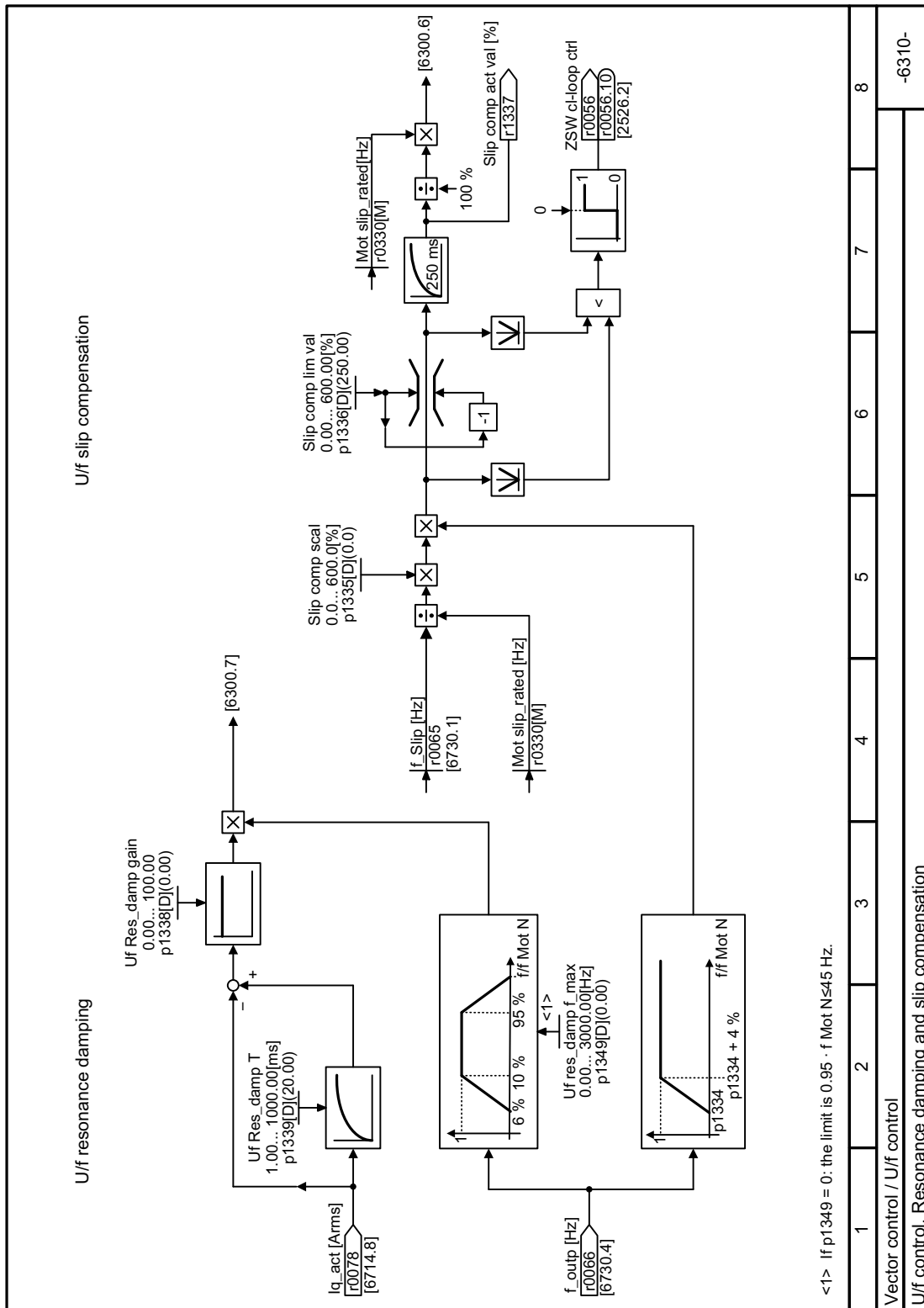

Figure 6-62 FP 6310

**Parameter**

Number	Name	Factory setting
r0071	Output voltage, maximum	Vrms
p0310[M]	Rated motor frequency	0 Hz
p1310[D]	Starting current (voltage boost) permanent	50%
p1311[D]	Starting current (voltage boost) when accelerating	0%
p1312[D]	Starting current (voltage boost) when starting	0%

Further information is provided in the parameter list.

### 6.6.2.3 U/f control with Standard Drive Control

#### Overview

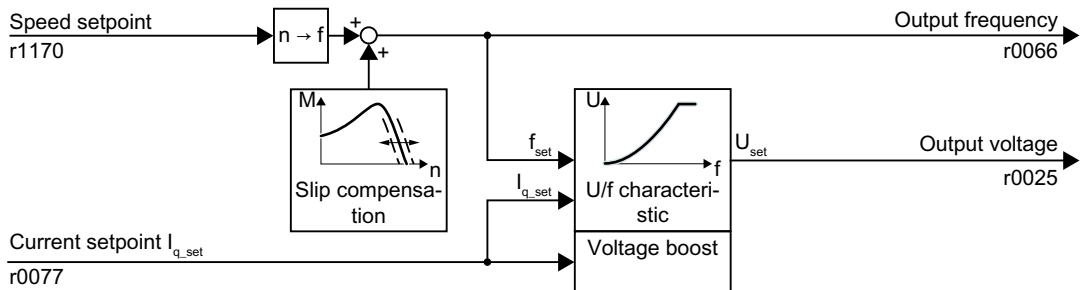

Figure 6-63 Default setting of the U/f control after selecting Standard Drive Control

Selecting application class Standard Drive Control in the quick commissioning adapts the structure and the setting options of the U/f control as follows:

- Starting current closed-loop control: At low speeds, a controlled motor current reduces the tendency of the motor to oscillate.
- With increasing speed, the converter changes from closed-loop starting current control to U/f control with load-dependent voltage boost.
- The slip compensation is activated.
- Soft starting is not possible.
- Reduced setting options

#### Function description

##### Characteristics after selecting the application class Standard Drive Control

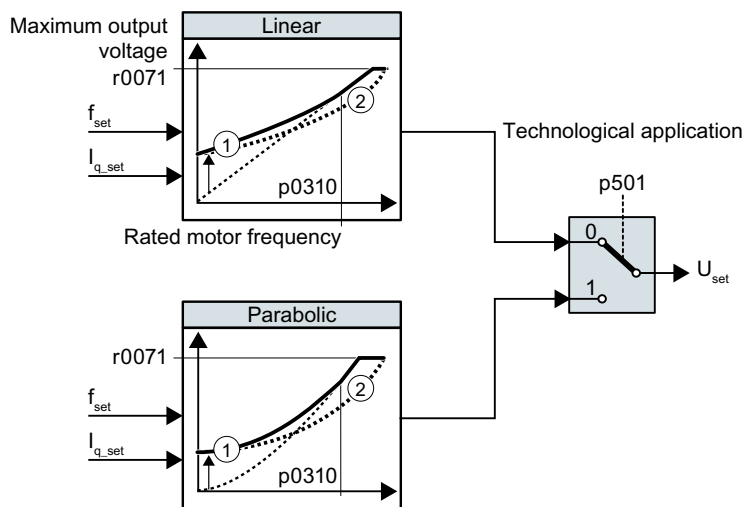

- ① The closed-loop starting current control optimizes the speed control at low speeds
- ② The converter compensates the voltage drop across the motor stator resistance

Figure 6-64 Characteristics after selecting Standard Drive Control

The application class Standard Drive Control reduces the number of characteristics and setting options:

- A linear and a parabolic characteristic are available.
- Selecting a technological application defines the characteristics.

Table 6-62 Linear and parabolic characteristics

Requirement	Application examples	Remark	Characteristic	Parameter
The required torque is independent of the speed	Eccentric-worm pump, compressor	-	Linear	p0501 = 0
The required torque increases with the speed	Centrifugal pumps, radial fans, axial fans	Lower losses in the motor and converter than with the linear characteristic.	Parabolic	p0501 = 1

## Parameters

Number	Name	Factory setting
r0025	CO: Output voltage, smoothed	- Vrms
r0066	CO: Output frequency	- Hz
r0071	Output voltage, maximum	- Vrms
p0310[M]	Rated motor frequency	0 Hz
p501	Technology application	0

### 6.6.2.4 Optimizing the motor start-up for application class Standard Drive Control

#### Overview

After selecting application class Standard Drive Control, in most applications no additional settings need to be made.

At standstill, the converter ensures that at least the rated motor magnetizing current flows. Magnetizing current p0320 approximately corresponds to the no-load current at 50% ... 80% of the rated motor speed.

In the following circumstances, the motor cannot accelerate to its speed setpoint after it has been switched on:

- Load moment of inertia too high
- Load torque too large
- Ramp-up time p1120 too short

The current can be increased at low speeds to improve the starting behavior of the motor.

#### Precondition

The ramp-up time of the ramp-function generator is, depending on the motor rated power, 1 s (< 1 kW) ... 10 s (> 10 kW).

#### Function description

##### Starting current (boost) after selecting the application class Standard Drive Control

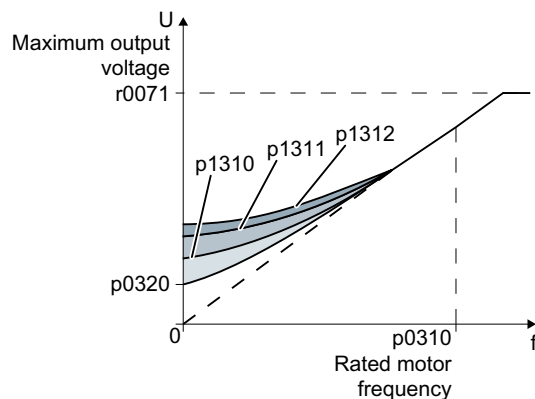

Figure 6-65 The resulting voltage boost using a linear characteristic as example

The converter boosts the voltage corresponding to the starting currents p1310 ... p1312.

Increase parameter values p1310 ... p1312 in steps of  $\leq 5\%$ . Excessively high values in p1310 ... p1312 can cause the motor to overheat and switch off (trip) the converter due to overcurrent.

If message A07409 appears, it is not permissible that you further increase the value of any of the parameters.

**Procedure**

1. Switch on the motor with a setpoint of a few revolutions per minute.
2. Check whether the motor rotates smoothly.
3. If the motor does not rotate smoothly, or even remains stationary, increase the voltage boost p1310 until the motor runs smoothly.
4. Accelerate the motor with the maximum load.
5. Check that the motor follows the setpoint.
6. If necessary, increase the voltage boost p1311 until the motor accelerates without problem.

In applications with a high break loose torque, you must also increase parameter p1312 in order to achieve a satisfactory motor response.

You have set the voltage boost.

**Parameters**

Number	Name	Factory setting
r0071	Output voltage, maximum	Vrms
p0310[M]	Rated motor frequency	0 Hz
p0320[M]	Rated motor magnetizing current / short-circuit current	0 Arms
p1310[D]	Starting current (voltage boost) permanent	50%
p1311[D]	Starting current (voltage boost) when accelerating	0%
p1312[D]	Starting current (voltage boost) when starting	0%





$I_d$  controllers keep the motor flux constant using the output voltage, and adjust the matching current component  $I_q$  in the motor.

### Settings that are required

Restart quick commissioning and select the vector control in quick commissioning.



Commissioning (Page 123)

In order to achieve a satisfactory control response, as a minimum you must set the partial functions – shown with gray background in the diagram above – to match your particular application:

- **Motor and current model:** In the quick commissioning, correctly set the motor data on the rating plate corresponding to the connection type (Y/ $\Delta$ ), and carry out the motor data identification routine at standstill.
- **Speed limits and torque limits:** In the quick commissioning, set the maximum speed (p1082) and current limit (p0640) to match your particular application. When exiting quick commissioning, the converter calculates the torque and power limits corresponding to the current limit. The actual torque limits are obtained from the converted current and power limits and the set torque limits.
- **Speed controller:** Start the rotating measurement of the motor data identification. You must manually optimize the controller if the rotating measurement is not possible.

Function diagrams

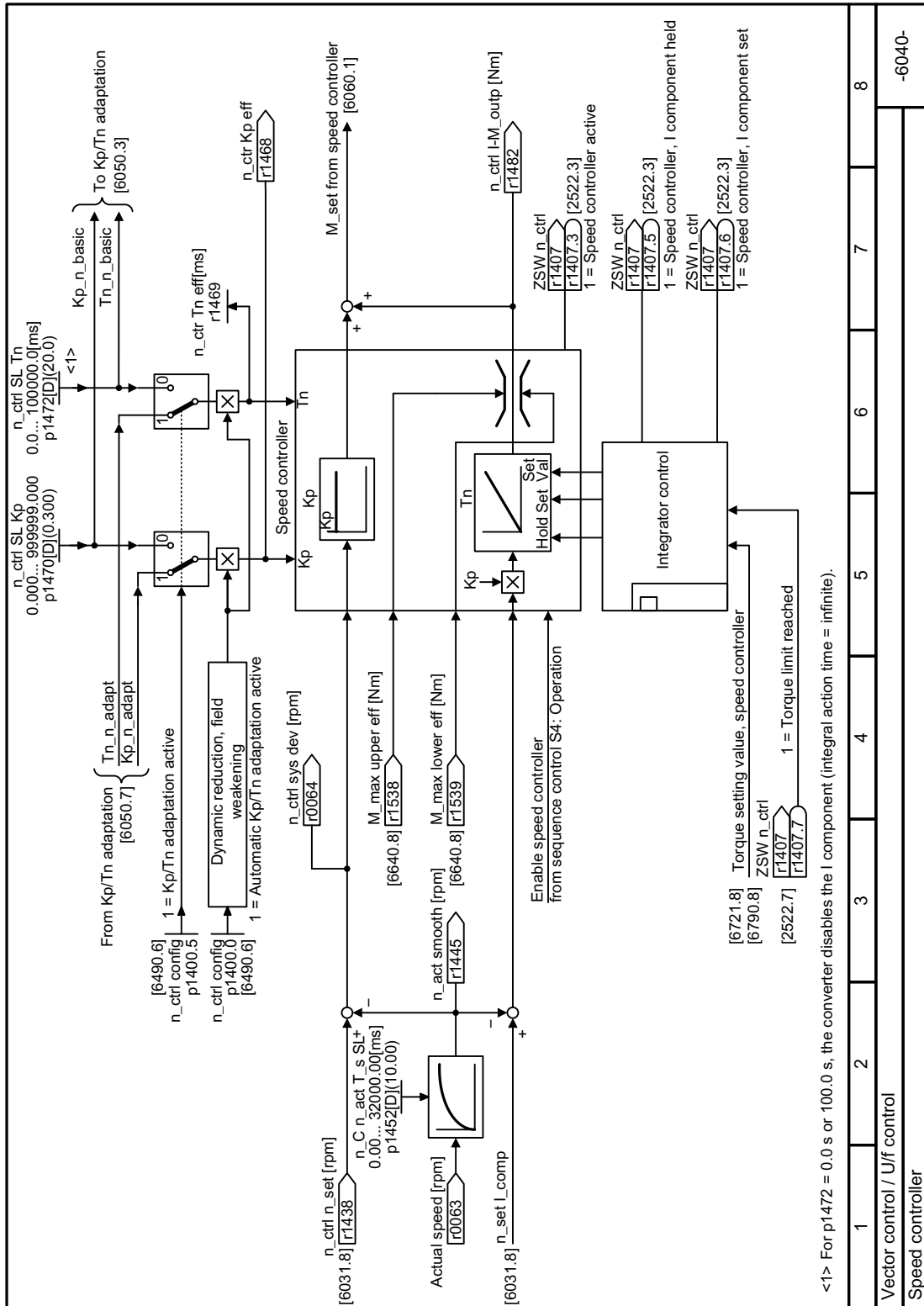

Figure 6-67 FP 6040



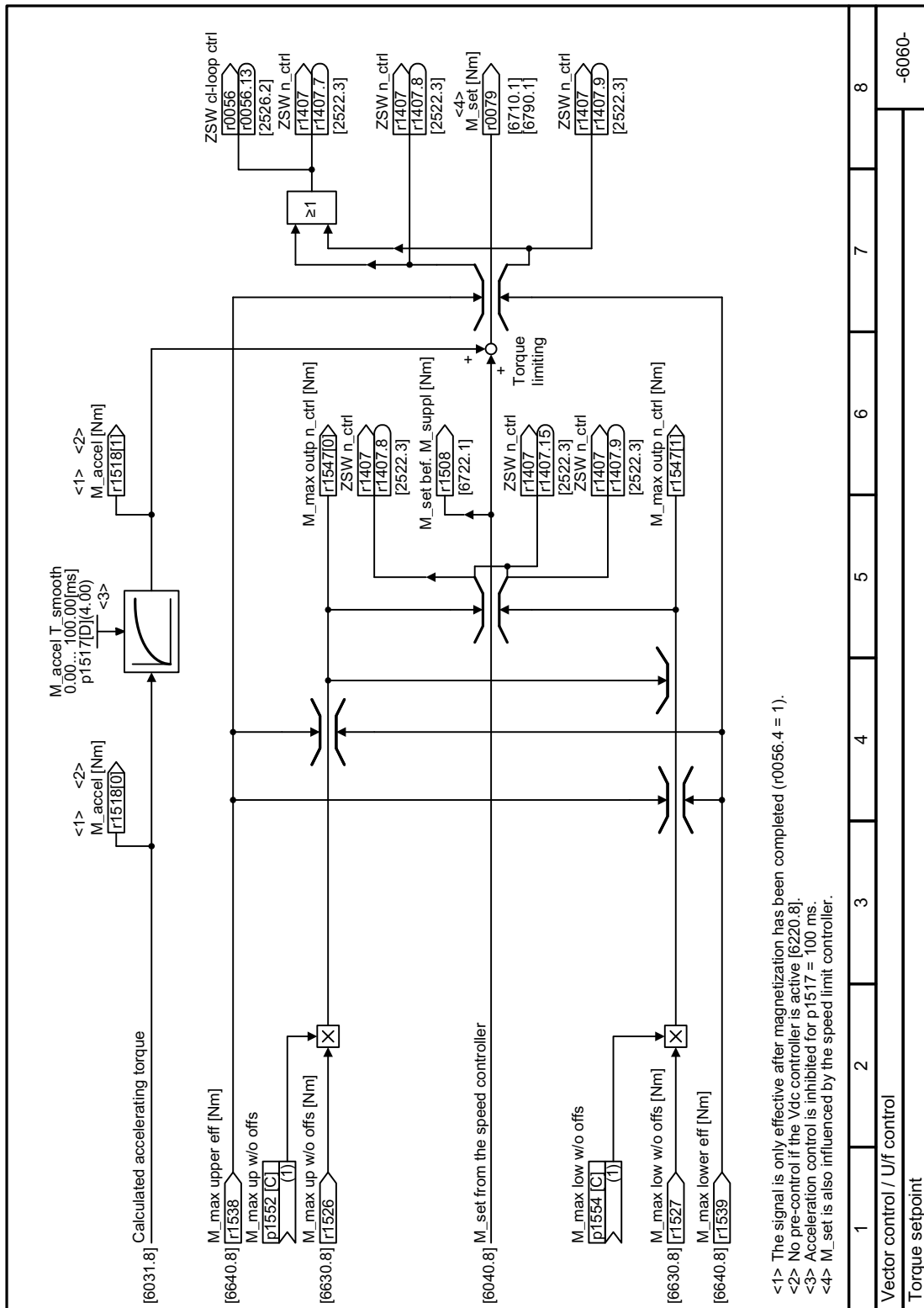

Figure 6-69 FP 6060

<1> The signal is only effective after magnetization has been completed (r0056.4 = 1).  
 <2> No pre-control if the Vdc controller is active [6220.8].  
 <3> Acceleration control is inhibited for p1517 = 100 ms.  
 <4> M\_set is also influenced by the speed limit controller.

## Default settings after selecting the application class Dynamic Drive Control

Selecting application class Dynamic Drive Control adapts the structure of the vector control and reduces the setting options:

	Vector control after selecting the application class Dynamic Drive Control	Vector control without selecting an application class
Hold or set the integral component of the speed controller	Not possible	Possible
Acceleration model for precontrol	Default setting	Can be activated
Motor data identification at standstill or with rotating measurement	Shortened, with optional transition into operation	Complete

### 6.6.3.2 Optimizing the speed controller

#### Optimum control response - post optimization not required

Preconditions for assessing the controller response:

- The moment of inertia of the load is constant and does not depend on the speed
- The converter does not reach the set torque limits during acceleration
- You operate the motor in the range 40 % ... 60 % of its rated speed

If the motor exhibits the following response, the speed control is well set and you do not have to adapt the speed controller manually:

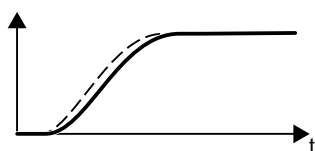

The speed setpoint (broken line) increases with the set ramp-up time and rounding.

The speed actual value follows the setpoint without any overshoot.

**Control optimization required**

In some cases, the self optimization result is not satisfactory, or self optimization is not possible as the motor cannot freely rotate.

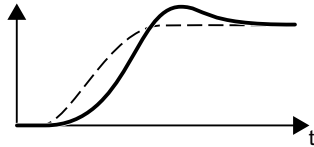

Initially, the speed actual value follows the speed setpoint with some delay, and then overshoots the speed setpoint.

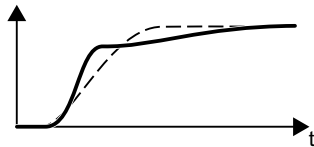

First, the actual speed value increases faster than the speed setpoint. Before the setpoint reaches its final value, it passes the actual value. Finally, the actual value approaches the setpoint without any significant overshoot.

In the two cases describe above, we recommend that you manually optimize the speed control.

**Optimizing the speed controller**

**Requirements**

- Torque precontrol is active: p1496 = 100 %.
- The load moment of inertia is constant and independent of the speed.
- The converter requires 10 % ... 50 % of the rated torque to accelerate.  
When necessary, adapt the ramp-up and ramp-down times of the ramp-function generator (p1120 and p1121).

**Procedure**

1. Switch on the motor.
2. Enter a speed setpoint of approximately 40 % of the rated speed.
3. Wait until the actual speed has stabilized.
4. Increase the setpoint up to a maximum of 60% of the rated speed.
5. Monitor the associated characteristic of the setpoint and actual speed.
6. Optimize the controller by adapting the ratio of the moments of inertia of the load and motor (p0342):

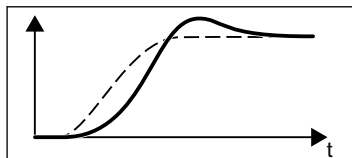

Initially, the speed actual value follows the speed setpoint with some delay, and then overshoots the speed setpoint.

- Increase p0342

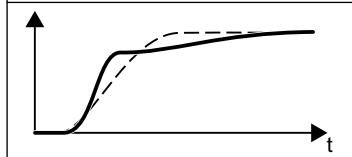

Initially, the speed actual value increases faster than the speed setpoint. The setpoint passes the actual value before reaching its final value. Finally, the actual value approaches the setpoint without any overshoot.

- Reduce p0342

7. Switch off the motor.

8. Set p0340 = 4. The converter again calculates the speed controller parameters.
9. Switch on the motor.
10. Over the complete speed range check as to whether the speed control operates satisfactorily with the optimized settings.

You have optimized the speed controller.



When necessary, set the ramp-up and ramp-down times of the ramp-function generator (p1120 and p1121) back to the value before optimization.

### Mastering critical applications

The drive control can become unstable for drives with a high load moment of inertia and gearbox backlash or a coupling between the motor and load that can possibly oscillate. In this case, we recommend the following settings:

- Increase p1452 (smoothing the speed actual value).
- Increase p1472 (integral time  $T_I$ ):  $T_I \geq 4 \cdot p1452$
- If, after these measures, the speed controller does not operate with an adequate dynamic performance, then increase p1470 (gain  $K_P$ ) step-by-step.

### Parameters

Table 6-63 Encoderless speed control

Number	Name	Factory setting
p0342[M]	Ratio between the total and motor moments of inertia	1
p1452	Speed controller actual speed value smoothing time (encoderless)	10 ms
p1470[D]	Speed controller encoderless operation P gain	0.3
p1472[D]	Speed controller encoderless operation integral time	20 ms
p1496[D]	Acceleration precontrol scaling	0%

## 6.6.4 Electrically braking the motor

### Overview



#### Braking with the motor in generator operation

If the motor brakes the connected load electrically, it converts the kinetic energy of the motor into electrical energy. The electrical energy  $E$  released on braking the load is proportional to the moment of inertia  $J$  of the motor and load and to the square of the speed  $n$ . The motor attempts to pass the energy on to the converter.

## Main features of the braking functions

### DC braking

DC braking prevents the motor from transferring the braking energy to the converter. The converter impresses a DC current into the motor, which brakes the motor. The motor converts the braking energy  $E$  of the load into heat.

- *Advantage:* The motor brakes the load without the converter having to process regenerative power.
- *Disadvantages:* significant increase in the motor temperature; no defined braking characteristics; no constant braking torque; no braking torque at standstill; braking energy  $E$  is lost as heat; does not function when the power fails

### Compound braking

One version of DC braking. The converter brakes the motor with a defined ramp-down time and superimposes a DC current on the output current.

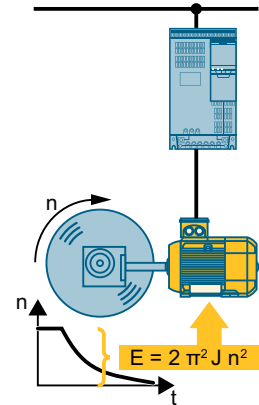



### 6.6.4.1 DC braking

#### Function description

##### NOTICE

##### Motor overheating as a result of DC braking

The motor will overheat if you use DC braking too frequently or use it for too long. This may damage the motor.

- Monitor the motor temperature.
- Allow the motor to adequately cool down between braking operations.
- If necessary, select another motor braking method.

With DC braking, the converter outputs an internal OFF2 command for the time that it takes to de-energize the motor p0347 - and then impresses the braking current for the duration of the DC braking.

The DC-braking function is possible only for induction motors.

4 different events initiate DC braking

##### DC braking when falling below a starting speed

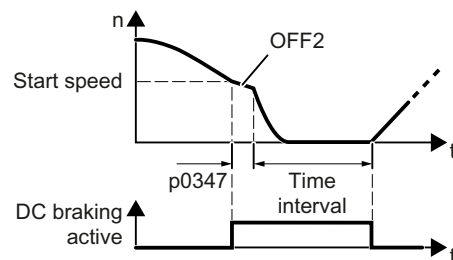

Precondition:

p1230 = 1 and p1231 = 14

Function:

1. The motor speed has exceeded the starting speed.
2. The converter activates the DC braking as soon as the motor speed falls below the starting speed.

##### DC braking when a fault occurs

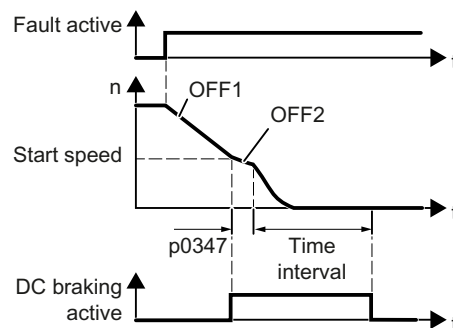

Precondition:

Fault number and fault response are assigned via p2100 and p2101.

Function:

1. A fault occurs, which initiates DC braking as response.
2. The motor brakes along the down ramp to the speed for the start of DC braking.
3. DC braking starts.

**DC braking initiated by a control command**

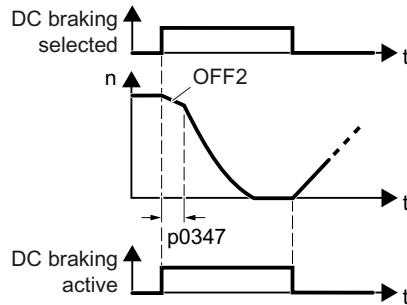

Precondition:

p1231 = 4 and p1230 = control command, e.g. p1230 = 722.3 (control command via DI 3)

Function:

1. The higher-level control issues the command for DC braking, e.g. using DI3: p1230 = 722.3.

2. DC braking starts.

If the higher-level control withdraws the command during DC braking, the converter interrupts DC braking and the motor accelerates to its setpoint.

**DC braking when the motor is switched off**

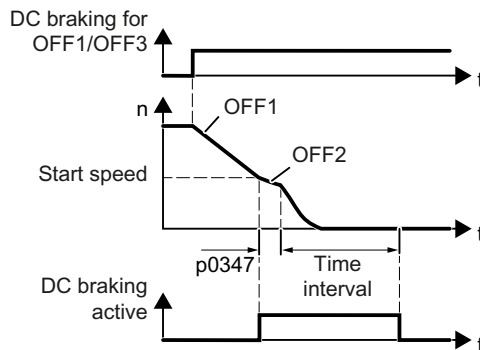

Precondition:

p1231 = 5 or p1230 = 1 and p1231 = 14

Function:

1. The higher-level control switches off the motor (OFF1 or OFF3).
2. The motor brakes along the down ramp to the speed for the start of DC braking.
3. DC braking starts.

**Parameters**

**Settings for DC braking**

Number	Name	Factory setting
p0347[M]	Motor de-excitation time	0 s
p1230[C]	BI: DC braking activation	0
p1231[M]	Configuring DC braking	0
p1232[M]	DC braking, braking current	0 Arms
p1233[M]	DC braking duration	1 s
p1234[M]	Speed at the start of DC braking	210000 rpm
r1239[8...13]	CO/BO: DC braking status word	-

Table 6-64 Configuring DC braking as a response to faults

Number	Name	Factory setting
p2100[0...19]	Changing the fault reaction, fault number	0
p2101[0...19]	Changing the fault reaction, reaction	0

### 6.6.4.2 Compound braking

#### Function description

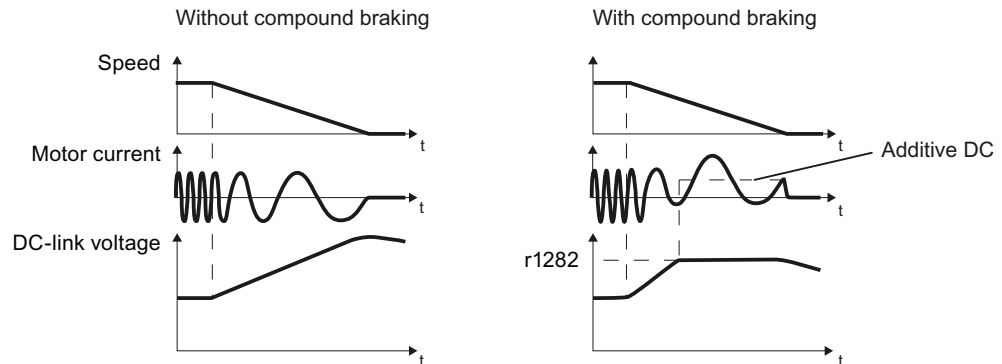

Figure 6-70 Motor brakes with and without active compound braking

Compound braking prevents the DC-link voltage increasing above a critical value. The converter activates compound braking depending on the DC-link voltage. Above a DC-link voltage threshold (r1282), the converter adds a DC current to the motor current. The DC current brakes the motor and prevents an excessive increase in the DC-link voltage.

#### Note

Compound braking is possible only with the U/f control.

Compound braking does not operate in the following cases:

- The "flying restart" function is active
- DC braking is active
- Vector control is selected

#### NOTICE

##### Overheating of the motor due to compound braking

The motor will overheat if you use compound braking too frequently or for too long. This may damage the motor.

- Monitor the motor temperature.
- Allow the motor to adequately cool down between braking operations.
- If necessary, select another motor braking method.

**Parameter**

Table 6-65 Setting and enabling compound braking

Number	Name	Factory setting
r1282	Vdc_max controller, switch-on level (U/f)	- V
p3856[D]	Compound braking current (%)	0 %
r3859.0	CO/BO: Compound braking/DC quantity control status word	-

**6.6.5 Pulse frequency wobbling**

**Note**

This function is only available for the converters of frame sizes FSH and FSJ.

**Overview**

Pulse frequency wobbling damps the spectral components, which can generate unwanted noise in the motor. Wobbling is activated by default for the converters of frame sizes FSH and FSJ.

Wobbling causes the pulse frequency in a modulation interval to deviate from the setpoint frequency. This means that the actual pulse frequency might be higher than the average pulse frequency required.

A noise generator can be used to vary the pulse frequency around an average value. In this case, the average pulse frequency is equal to the setpoint pulse frequency. The pulse frequency can be varied in every current controller cycle if the cycle is constant. Current measurement errors resulting from asynchronous pulse and control intervals are compensated by a correction in the actual current value.

Parameter p1811[0...n] can be set to adjust the magnitude of variation in the pulse frequency wobble between 0 and 20%. The factory setting is 10%. For a wobble amplitude of p1811 = 0%, the maximum possible pulse frequency is  $p1800 = 2 \times 1/\text{current controller cycle}$  (4 kHz). With a wobble amplitude setting of p1811 > 0, the maximum possible pulse frequency is  $p1800 = 1/\text{current controller cycle}$  (2 kHz). These conditions apply to all indices.

**Parameters**

Parameter	Description	Factory setting
p1811	Pulse frequency wobulation amplitude	10%

 For more information about the parameters, see Chapter "Parameter list (Page 376)".

## 6.7 Drive protection

### 6.7.1 Overcurrent protection

#### Overview



The U/f control prevents too high a motor current by influencing the output frequency and the motor voltage (I-max controller).

#### Precondition

You have selected U/f control.

The application must allow the motor torque to decrease at a lower speed.

#### Function description

The I-max controller influences the output frequency and the motor voltage.

If the motor current reaches the current limit during acceleration, the I-max controller extends the acceleration operation.

If the motor load is so high during steady-state operation that the motor current reaches the current limit, then the I-max controller reduces the speed and the motor voltage until the motor current returns to the permissible range again.

If the motor current reaches the current limit during deceleration, the I-max controller extends the deceleration operation.

#### Parameters

You only have to change the factory settings of the I-max controller if the drive tends to oscillate when it reaches the current limit or if it is shut down due to overcurrent.

Table 6-66 I-max controller parameters

Number	Name	Factory setting
r0056.0 ... 13	CO/BO: Status word, closed-loop control	-
p0305[M]	Rated motor current	0 Arms
p0640[D]	Current limit	0 Arms
p1340[D]	I_max frequency controller proportional gain	0
p1341[D]	I_max frequency controller integral time	0.300 s
r1343	CO: I_max controller frequency output	- rpm

You will find more information about this function in function diagram 6300 and in the parameter list.

## 6.7.2 Converter protection using temperature monitoring

### Overview



The converter temperature is essentially defined by the following effects:

- The ambient temperature
- The ohmic losses increasing with the output current
- Switching losses increasing with the pulse frequency

#### Monitoring types

The converter monitors its temperature using the following monitoring types:

- $I^2t$  monitoring (alarm A07805, fault F30005)
- Measuring the chip temperature of the Power Module (alarm A05006, fault F30024)
- Measuring the heat sink temperature of the Power Module (alarm A05000, fault F30004)

### Function description

#### Overload response for p0290 = 0

The converter responds depending on the control mode that has been set:

- In vector control, the converter reduces the output current.
- In U/f control, the converter reduces the speed.

Once the overload condition has been removed, the converter re-enables the output current or speed.

If the measure cannot prevent a converter thermal overload, then the converter switches off the motor with fault F30024.

#### Overload response for p0290 = 1

The converter immediately switches off the motor with fault F30024.

#### Overload response for p0290 = 2

We recommend this setting for drives with square-law torque characteristic, e.g. fans.

The converter responds in 2 stages:

1. If you operate the converter with increased pulse frequency setpoint p1800, then the converter reduces its pulse frequency starting at p1800. In spite of the temporarily reduced pulse frequency, the base-load output current remains unchanged at the value that is assigned to parameter p1800.

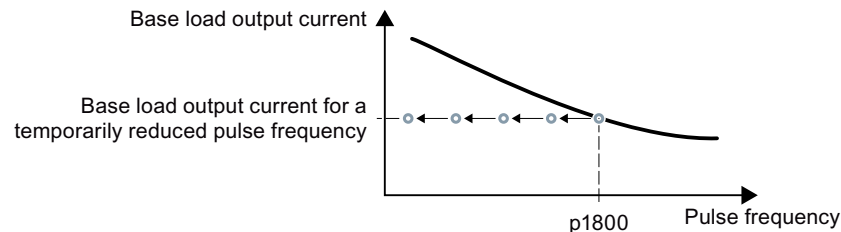

Figure 6-71 Derating characteristic and base load output current for overload

Once the overload condition has been removed, the converter increases the pulse frequency back to the pulse frequency setpoint p1800.

2. If it is not possible to temporarily reduce the pulse frequency, or the risk of thermal overload cannot be prevented, then stage 2 follows:
  - In vector control, the converter reduces its output current.
  - In U/f control, the converter reduces the speed.

Once the overload condition has been removed, the converter re-enables the output current or speed.

If both measures cannot prevent a power unit thermal overload, then the converter switches off the motor with fault F30024.

### Overload response for p0290 = 3

If you operate the converter with increased pulse frequency, then the converter reduces its pulse frequency starting at the pulse frequency setpoint p1800.

In spite of the temporarily reduced pulse frequency, the maximum output current remains unchanged at the value that is assigned to the pulse frequency setpoint. Also see p0290 = 2.

Once the overload condition has been removed, the converter increases the pulse frequency back to the pulse frequency setpoint p1800.

If it is not possible to temporarily reduce the pulse frequency, or the measure cannot prevent a power unit thermal overload, then the converter switches off the motor with fault F30024.

**Overload response for p0290 = 12**

The converter responds in 2 stages:

1. If you operate the converter with increased pulse frequency setpoint p1800, then the converter reduces its pulse frequency starting at p1800.  
 There is no current derating as a result of the higher pulse frequency setpoint.  
 Once the overload condition has been removed, the converter increases the pulse frequency back to the pulse frequency setpoint p1800.
2. If it is not possible to temporarily reduce the pulse frequency, or the risk of converter thermal overload cannot be prevented, then stage 2 follows:
  - In vector control, the converter reduces the output current.
  - In U/f control, the converter reduces the speed.
 Once the overload condition has been removed, the converter re-enables the output current or speed.

If both measures cannot prevent a power unit thermal overload, then the converter switches off the motor with fault F30024.

**Overload response for p0290 = 13**

We recommend this setting for drives with a high starting torque.

If you operate the converter with increased pulse frequency, then the converter reduces its pulse frequency starting at the pulse frequency setpoint p1800.

There is no current derating as a result of the higher pulse frequency setpoint.

Once the overload condition has been removed, the converter increases the pulse frequency back to the pulse frequency setpoint p1800.

If it is not possible to temporarily reduce the pulse frequency, or the measure cannot prevent a power unit thermal overload, then the converter switches off the motor with fault F30024.

**Parameters**

Number	Name	Factory setting
r0036	CO: Power unit overload I2t	%
r0037[0...19]	Power unit temperatures	°C
p0290	Power unit overload response	2
p0292[0...1]	Power unit temperature alarm threshold	[0] 5 °C, [1] 15 °C
p0294	Power Module alarm for I2t overload	95%



### 6.7.3 Motor protection with temperature sensor

#### Overview



The converter can evaluate one of the following sensors to protect the motor against overtemperature:

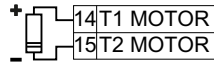

- KTY84 sensor
- Temperature switch (e.g. bimetallic switch)

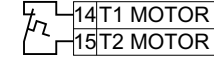

- PTC sensor
- Pt1000 sensor

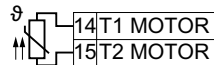

#### Function description

##### KTY84 sensor

###### NOTICE

###### Overheating of the motor due to KTY sensor connected with the incorrect polarity

If a KTY sensor is connected with incorrect polarity, the motor can be damaged by overheating, as the converter cannot detect a motor overtemperature condition.

- Connect the KTY sensor with the correct polarity.



Using a KTY sensor, the converter monitors the motor temperature and the sensor itself for wire-break or short-circuit:

- Temperature monitoring:
  - The converter uses a KTY sensor to evaluate the motor temperature in the range from  $-48\text{ °C}$  ...  $+248\text{ °C}$ .
  - Set the temperature for the alarm and fault thresholds with parameter p0604 or p0605.
    - Overtemperature alarm (A07910):
      - motor temperature  $>$  p0604 and p0610 = 0
    - Overtemperature fault (F07011):
      - The converter responds with a fault in the following cases:
        - motor temperature  $>$  p0605
        - motor temperature  $>$  p0604 and p0610  $>$  0
- Sensor monitoring (A07015 or F07016):
  - Wire-break:
    - The converter interprets a resistance  $>$   $2120\ \Omega$  as a wire-break and outputs the alarm A07015. After 100 milliseconds, the converter changes to the fault state with F07016.
  - Short-circuit:
    - The converter interprets a resistance  $<$   $50\ \Omega$  as a short-circuit and outputs the alarm A07015. After 100 milliseconds, the converter changes to the fault state with F07016.

**Bimetallic switch**



The converter interprets a resistance  $\geq 100 \Omega$  as an opened bimetallic switch and responds according to the setting for p0610.

**PTC sensor**



The converter interprets a resistance  $> 1650 \Omega$  as being an overtemperature and responds according to the setting for p0610.

The converter interprets a resistance  $< 20 \Omega$  as being a short-circuit and responds with alarm A07015. If the alarm is present for longer than 100 milliseconds, the converter shuts down with fault F07016.

**Pt1000 sensor**



Using a Pt1000 sensor, the converter monitors the motor temperature and the sensor itself for wire breakage and/or short-circuit:

- Temperature monitoring:
  - Using a Pt1000 sensor, the converter evaluates the motor temperature in the range from  $-48 \text{ °C} \dots +248 \text{ °C}$ .
  - Set the temperature for the alarm and fault thresholds with parameter p0604 or p0605.
    - Overtemperature alarm (A07910):
      - motor temperature  $> p0604$  and  $p0610 = 0$
    - Overtemperature fault (F07011):
      - The converter responds with a fault in the following cases:
        - motor temperature  $> p0605$
        - motor temperature  $> p0604$  and  $p0610 > 0$
- Sensor monitoring (A07015 or F07016):
  - Wire-break:
    - The converter interprets a resistance  $> 2120 \Omega$  as a wire-break and outputs the alarm A07015. After 100 milliseconds, the converter changes to the fault state with F07016.
  - Short-circuit:
    - The converter interprets a resistance  $< 603 \Omega$  as a short-circuit and outputs the alarm A07015. After 100 milliseconds, the converter changes to the fault state with F07016.

**Parameters**

Number	Name	Factory setting
p0335[M]	Type of motor cooling	0
p0601[M]	Motor temperature sensor type	0
p0604[M]	Mot_temp_mod 2/sensor alarm threshold	130 °C
p0605[M]	Mot_temp_mod 1/2/sensor threshold and temperature value	145 °C
p0610[M]	Motor overtemperature response	12
p0640[D]	Current limit	0 Arms

## 6.7.4 Motor protection by calculating the temperature

### Overview



The converter calculates the motor temperature based on a thermal motor model.

The thermal motor model responds far faster to temperature increases than a temperature sensor.

If the thermal motor model is used together with a temperature sensor, e.g. a Pt1000, then the converter corrects the model according to the measured temperature.

### Function description

#### Thermal motor model 2 for induction motors

The thermal motor model 2 for induction motors is a thermal 3-mass model, consisting of stator core, stator winding and rotor. Thermal motor model 2 calculates the temperatures - both in the rotor as well as in the stator winding.

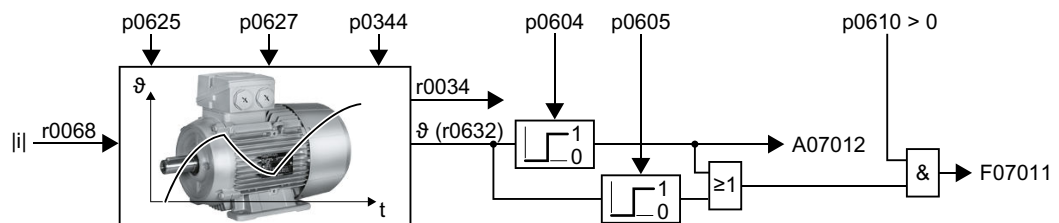

Figure 6-72 Thermal motor model 2 for induction motors

### Parameters

Table 6-67 Thermal motor model 2 for induction motors

Number	Name	Factory setting
r0034	CO: Thermal motor load	- %
r0068[0 ... 1]	CO: Absolute actual current value	- Arms
p0344[M]	Motor weight (for thermal motor model)	0 kg
p0604[M]	Mot_temp_mod 2/KTY alarm threshold	130 °C
p0605[M]	Mot_temp_mod 1/2/sensor threshold and temperature value	145 °C
p0610[M]	Motor overtemperature response	12
p0612[M]	Mot_temp_mod activation	0000 0010 0000 0010 bin
p0625[M]	Motor ambient temperature during commissioning	20 °C
p0627[M]	Motor overtemperature, stator winding	80 K
r0632[M]	Mot_temp_mod stator winding temperature	- °C
p0640[D]	Current limit	0 Arms

Further information is provided in the parameter list.

**Thermal motor model 1 for synchronous reluctance motors**

Thermal motor model 1 calculates the temperature of the stator winding from the motor current and the thermal time constant of the motor model.

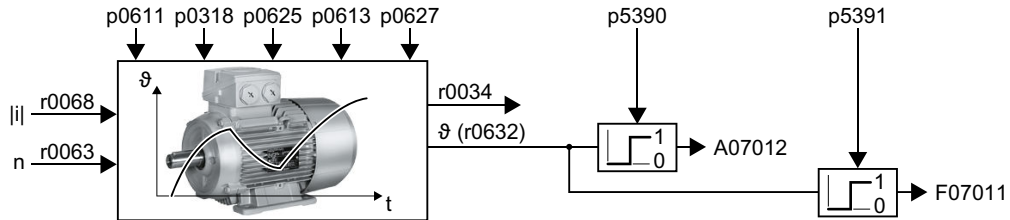

Figure 6-73 Thermal motor model 1 for reluctance motors

**Parameters**

Table 6-68 Thermal motor model 1 for reluctance motors

Number	Name	Factory setting
r0034	CO: Thermal motor load	- %
r0068[0 ... 1]	CO: Absolute actual current value	- Arms
p0318[M]	Motor stall current	0 Arms
p0610[M]	Motor overtemperature response	12
p0611[M]	I <sup>2</sup> t thermal motor model time constant	0 s
p0612[M]	Mot_temp_mod activation	0000 0010 0000 0010 bin
p0613[M]	Mot_temp_mod 1/3 ambient temperature	20 °C
p0625[M]	Motor ambient temperature during commissioning	20 °C
p0627[M]	Motor overtemperature, stator winding	80 K
r0632[M]	Mot_temp_mod stator winding temperature	- °C
p5390[M]	Mot_temp_mod 1/3 alarm threshold	110 °C
p5391[M]	Mot_temp_mod 1/3 fault threshold	120 °C

Further information is provided in the parameter list.

## 6.7.5 Motor and converter protection by limiting the voltage

### Overview



An electric motor converts electrical energy into mechanical energy to drive the load. If the motor is driven by its load, e.g. by the inertia of the load during braking, the energy flow reverses: The motor operates temporarily as a generator, and converts mechanical energy into electrical energy. The electrical energy flows from the motor to the converter. The converter stores the energy in its DC-link capacitors. The DC-link voltage  $V_{dc}$  is consequently higher in the converter.

An excessively high DC-link voltage damages both the converter and the motor. The converter therefore monitors its DC-link voltage and, when necessary, switches off the connected motor and outputs the fault "DC-link overvoltage".

### Function description

#### Protecting the motor and converter against overvoltage

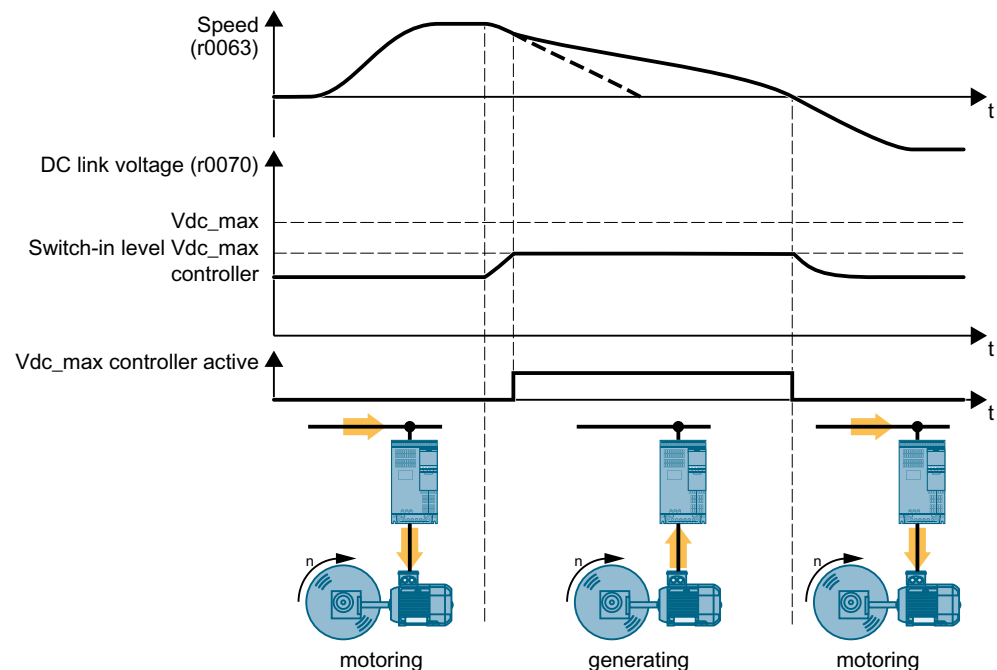

Figure 6-74 Simplified representation of the  $V_{dc\_max}$  control

The  $V_{dc\_max}$  control lengthens the motor ramp-down time when braking. Consequently, the motor feeds only so much energy back into the converter to cover the losses in the converter. The DC-link voltage remains within the permissible range.



Electrically braking the motor (Page 317)

## Parameters

The parameters differ depending on the motor control mode.

Table 6-69 Parameters for U/f control

Number	Name	Factory setting
p0210	Device supply voltage	400 V
p1280[D]	Vdc controller configuration (U/f)	1
r1282	Vdc_max controller, switch-on level (U/f)	- V
p1283[D]	Vdc_max controller, dynamic factor (U/f)	100%
p1284[D]	Vdc_max controller, time threshold (U/f)	4 s
p1290[D]	Vdc controller proportional gain (U/f)	1
p1291[D]	Vdc controller integral time (U/f)	40 ms
p1292[D]	Vdc controller derivative-action time (U/f)	10 ms
p1294	Vdc_max controller ON level for automatic detection (U/f)	0

Table 6-70 Parameters for vector control

Number	Name	Factory setting
p0210	Device supply voltage	400 V
p1240[D]	Vdc controller configuration (vector control)	1
r1242	Vdc_max controller, switch-on level	- V
p1243[D]	Vdc_max controller, dynamic factor	100%
p1250[D]	Vdc controller proportional gain	1
p1251[D]	Vdc controller integral time	0 ms
p1252[D]	Vdc controller derivative-action time	0 ms
p1254	Vdc_max controller ON level for automatic detection	0

Further information is provided in the parameter list.

### 6.7.6 Monitoring the driven load





In many applications, the speed and the torque of the motor can be used to determine whether the driven load is in an impermissible operating state. The use of an appropriate monitoring function in the converter prevents failures and damage to the machine or plant.

Examples:

- For fans, an excessively low torque indicates a torn drive belt.
- For pumps, insufficient torque can indicate a leakage or dry-running.
- The motor can be blocked by an excessively high torque at a low speed.

## Functions for monitoring the driven load

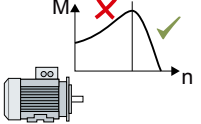
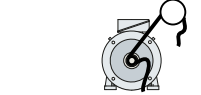
The converter provides the following means to monitor the driven load via the torque of the motor:

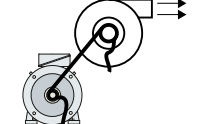
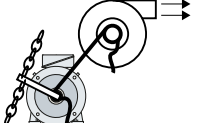
	The stall protection recognizes a stalled asynchronous motor.
	The no-load monitoring evaluates the motor current. Insufficient current indicates that the motor and the load are no longer mechanically connected with each other.
	The blocking protection triggers for a motor current that corresponds to the set current limit coupled with motor standstill.
	<p>The torque monitoring assumes that a specific torque is associated with each speed for pumps and fans. Insufficient torque indicates that the motor and the load are no longer mechanically connected.</p> <p>An excessive torque can indicate problems in the mechanical system of the driven load, e.g. a mechanically blocked load.</p>
	Blocking protection, leakage protection and dry-running protection are a monitoring method for pumps or fans. The monitoring combines a torque monitoring with a blocking protection.

Monitoring the driven load with a binary signal:

	The speed monitoring evaluates a periodic binary signal. A signal failure indicates that the motor and the load are no longer mechanically connected with each other.
---	---

6.7.6.1 Stall protection

Function description

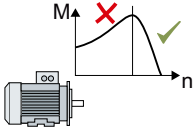

If the load of a standard induction motor exceeds the stall torque of the motor, the motor can also stall during operation on the converter. A stalled motor is stationary and does not develop sufficient torque to accelerate the load.

If the "Motor model fault signal stall detection" r1746 for the time p2178 is present via the "Motor model error threshold stall detection" p1745, the converter signals "Motor stalled" and fault F07902.

Parameters

Number	Name	Factory setting
r1408[0 ... 14]	CO/BO: Status word, current controller	-
p1745[D]	Motor model error threshold stall detection	5%
r1746	Motor model fault signal stall detection	- %
p2178[D]	Motor stalled delay time	0.01 s
r2198	CO/BO: Status word monitoring functions 2	-

6.7.6.2 No-load monitoring

Function description



An inadequate motor current indicates an interruption in the power transmission from the motor to the load.

If the motor current for the time p2180 lies below the current level p2179, the converter signals "output load not available" and alarm A07929.

Parameters

Number	Name	Factory setting
r0068[0 ... 1]	CO: Absolute actual current value	- Arms
p2179[D]	Output load detection current limit	0 Arms
p2180[D]	Output load detection delay time	2000 ms
r2197[0 ... 13]	CO/BO: Status word monitoring functions 1	-



### 6.7.6.3 Blocking protection

#### Function description



If the mechanical load is too high, the motor may block. For a blocked motor, the motor current corresponds to the set current limit without the speed reaching the specified setpoint.

If the speed lies below the speed threshold p2175 for the time p2177 while the motor current reaches the current limit, the converter signals "Motor blocked" and fault F07900.

#### Parameters

Number	Name	Factory settings
p0045	Display values of smoothing time constant	4 ms
r0063	CO: Speed actual value	- rpm
p2175[D]	Motor blocked speed threshold	120 rpm
p2177[D]	Motor blocked delay time	3 s
r2198	Status word monitoring functions 2	-

### 6.7.6.4 Torque monitoring

#### Function description

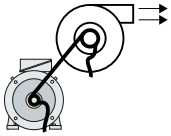

In applications with fans, pumps or compressors with the flow characteristic, the torque follows the speed according to a specific characteristic. An insufficient torque for fans indicates that the power transmission from the motor to the load is interrupted. For pumps, insufficient torque can indicate a leakage or dry-running.

The converter monitors the torque based on the envelope curve depending on the speed against a lower and upper torque.

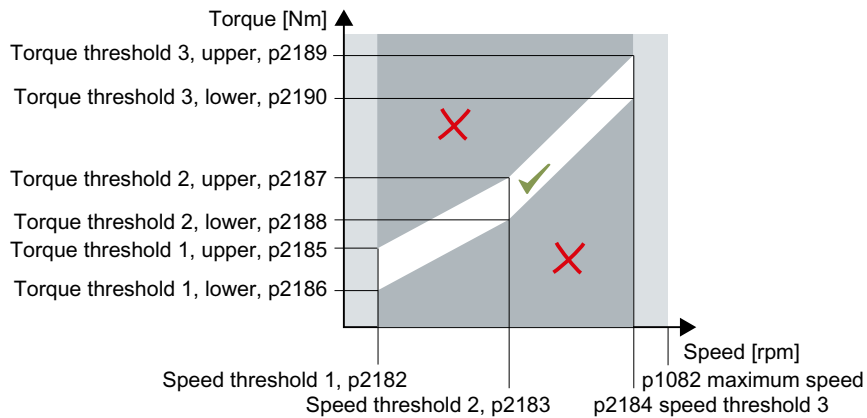

If the torque lies in the impermissible range longer than time p2192, the converter reacts as specified in p2181.

The monitoring is not active below speed threshold 1 and above speed threshold 3.

#### Parameters

Number	Name	Factory setting
p2181[D]	Load monitoring, response	0
p2182[D]	Load monitoring, speed threshold 1	150 rpm
p2183[D]	Load monitoring, speed threshold 2	900 rpm
p2184[D]	Load monitoring, speed threshold 3	1500 rpm
p2185[D]	Load monitoring, torque threshold 1, upper	10000000 Nm
p2186[D]	Load monitoring torque threshold 1, lower	0 Nm
p2187[D]	Load monitoring torque threshold 2, upper	10000000 Nm
p2188[D]	Load monitoring torque threshold 2, lower	0 Nm
p2189[D]	Load monitoring torque threshold 3, upper	10000000 Nm
p2190[D]	Load monitoring torque threshold 3, lower	0 Nm
p2191[D]	Load monitoring torque threshold, no load	0 Nm
p2192[D]	Load monitoring, delay time	10 s
p2193[D]	Load monitoring configuration	1

### 6.7.6.5 Blocking protection, leakage protection and dry-running protection

#### Overview

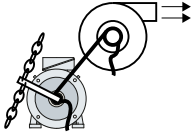

In applications with fans, pumps or compressors with the flow characteristic, the torque follows the speed according to a specific characteristic. An insufficient torque for fans indicates that the power transmission from the motor to the load is interrupted. For pumps, insufficient torque can indicate a leakage or dry-running.

#### Function description

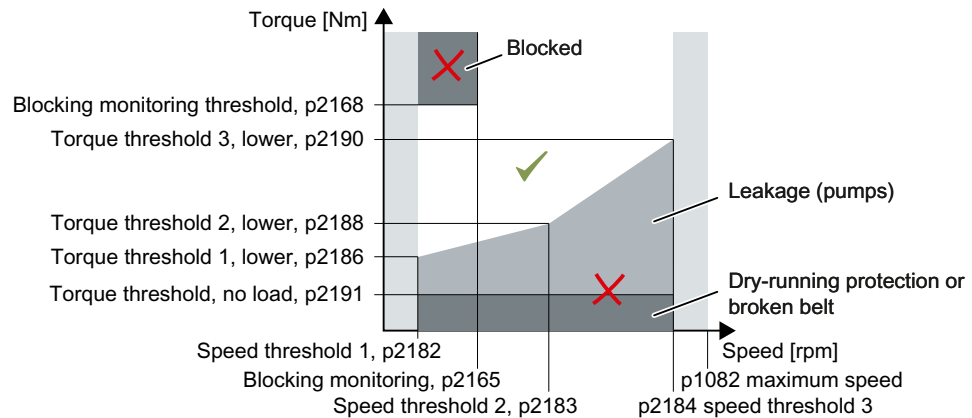

If the torque and speed lie in the impermissible range longer than time p2192, the converter reacts as specified in p2181.

For applications with pumps (p2193 = 4), the converter detects the following states of the driven load:

- Blocked
- Leakage
- Dry running

For applications with fans or compressors (p2193 = 5), the converter detects the following states of the driven load:

- Blocked
- Torn belt

The monitoring is not active below speed threshold 1 and above speed threshold 3.

When using the control mode "U/f control" (p1300 < 10), the "Blocking protection" function becomes active when the current limit is reached.

 Blocking protection (Page 335)

## Parameters

Number	Name	Factory setting
p1082[D]	Maximum speed	1500 rpm
p1300[D]	Open-loop/closed-loop control operating mode	See parameter list
p2165[D]	Load monitoring blocking monitoring threshold, upper	0 rpm
p2168[D]	Load monitoring blocking monitoring torque threshold	10000000 Nm
p2181[D]	Load monitoring, response	0
p2182[D]	Load monitoring, speed threshold 1	150 rpm
p2183[D]	Load monitoring, speed threshold 2	900 rpm
p2184[D]	Load monitoring, speed threshold 3	1500 rpm
p2186[D]	Load monitoring torque threshold 1, lower	0 Nm
p2188[D]	Load monitoring torque threshold 2, lower	0 Nm
p2190[D]	Load monitoring torque threshold 3, lower	0 Nm
p2191[D]	Load monitoring torque threshold, no load	0 Nm
p2192[D]	Load monitoring, delay time	10 s
p2193[D]	Load monitoring configuration	1

### 6.7.6.6 Rotation monitoring

#### Function description

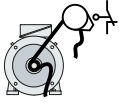

The converter monitors the speed or velocity of a machine component via an electromechanic or electronic encoder, e.g. a proximity switch. Examples of how the function can be used:

- Drive belt monitoring for fans
- Blocking protection for pumps

The converter checks whether the encoder consistently supplies a 24 V signal during motor operation. If the encoder signal fails for time p2192, the converter signals fault F07936.

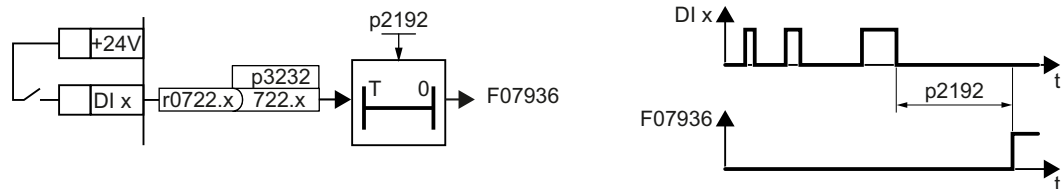

Figure 6-75 Function plan and time response of the speed monitoring

#### Parameters

Number	Name	Factory setting
r0722	CO/BO: CU digital inputs, status	-
p2192[D]	Load monitoring, delay time	10 s
p2193[D]	Load monitoring configuration	1
p3232[C]	BI: Load monitoring, failure detection	1

Further information is provided in the parameter list.

## 6.8 Drive availability

### 6.8.1 Flying restart – switching on while the motor is running



If you switch on the motor while it is still rotating, without the "Flying restart" function, there is a high probability that a fault will occur as a result of overcurrent (F30001 or F07801). Examples of applications involving an unintentionally rotating motor directly before switching on:

- The motor rotates after a brief line interruption.
- A flow of air turns the fan impeller.
- A load with a high moment of inertia drives the motor.

#### Principle of operation

The "Flying restart" function comprises the following steps:

1. After the on command, the converter impresses the search current in the motor and increases the output frequency.
2. When the output frequency reaches the actual motor speed, the converter waits for the motor excitation build up time.
3. The converter accelerates the motor to the actual speed setpoint.

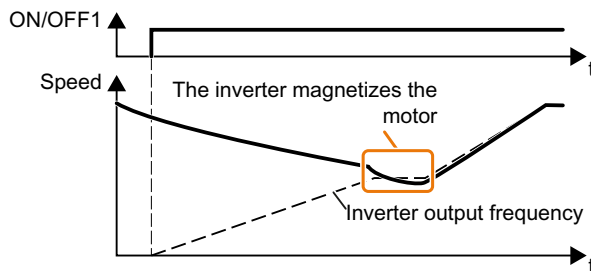

Figure 6-76 Principle of operation of the "flying restart" function

#### Parameters

Table 6-71 Setting "flying restart" function

Number	Name	Factory setting
p1200[D]	Flying restart operating mode	0

#### No "Flying restart" function for group drives

It is not permissible that you enable the "Flying restart" function if the converter is simultaneously driving several motors.

Exception: a mechanical coupling ensures that all of the motors always operate with the same speed.

Table 6-72 Advanced settings

Number	Name	Factory setting
r0331[M]	Actual motor magnetizing current / short-circuit current	- Arms
p0346[M]	Motor excitation build-up time	0 s
p0347[M]	Motor de-excitation time	0 s
p1201[C]	BI: Flying restart enable signal source	1
p1202[D]	Flying restart detection current	90% / 100%
p1203[D]	Flying restart search rate factor	150% / 100%

## 6.8.2 Automatic restart

### Overview



The automatic restart includes two different functions:

- The converter automatically acknowledges faults.
- After a fault occurs or after a power failure, the converter automatically switches-on the motor again.

The converter interprets the following events as power failure:

- The converter signals fault F30003 (undervoltage in the DC link), after the converter line voltage has been briefly interrupted.
- All the converter power supplies have been interrupted and all the energy storage devices in the converter have discharged to such a level that the converter electronics fail.

### Function description

#### Setting the automatic restart function

**⚠ WARNING**

**Unexpected machine motion caused by the active automatic restart function**

When the "automatic restart" function is active ( $p1210 > 1$ ), the motor automatically starts after a line supply phase. Unexpected movement of machine parts can result in serious injury and material damage.

- Block off hazardous areas within the machine to prevent inadvertent access.

If it is possible that the motor is still rotating for a longer period of time after a power failure or after a fault, then you must also activate the "flying restart" function.



Flying restart – switching on while the motor is running (Page 340)

Using p1210, select the automatic restart mode that best suits your application.

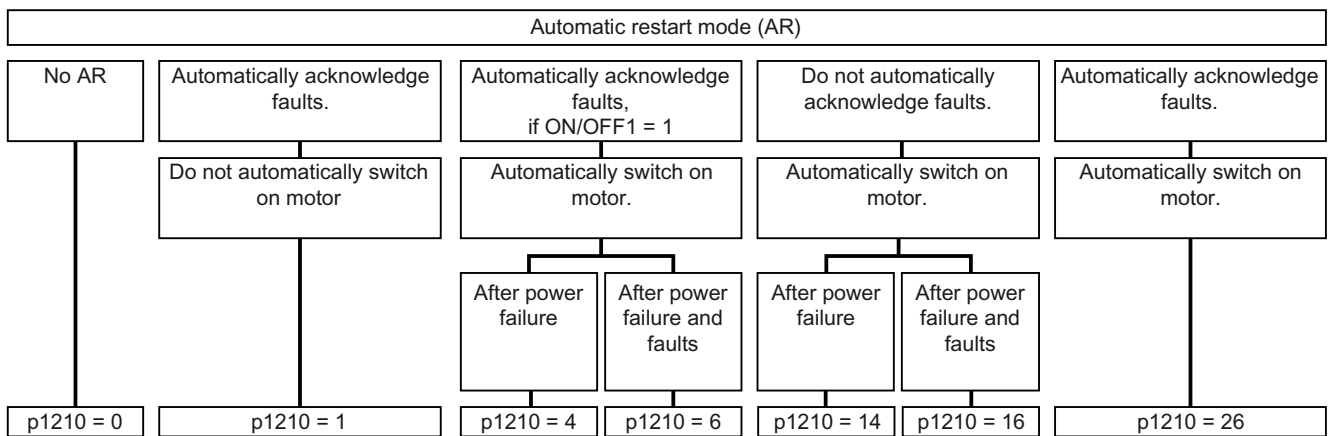
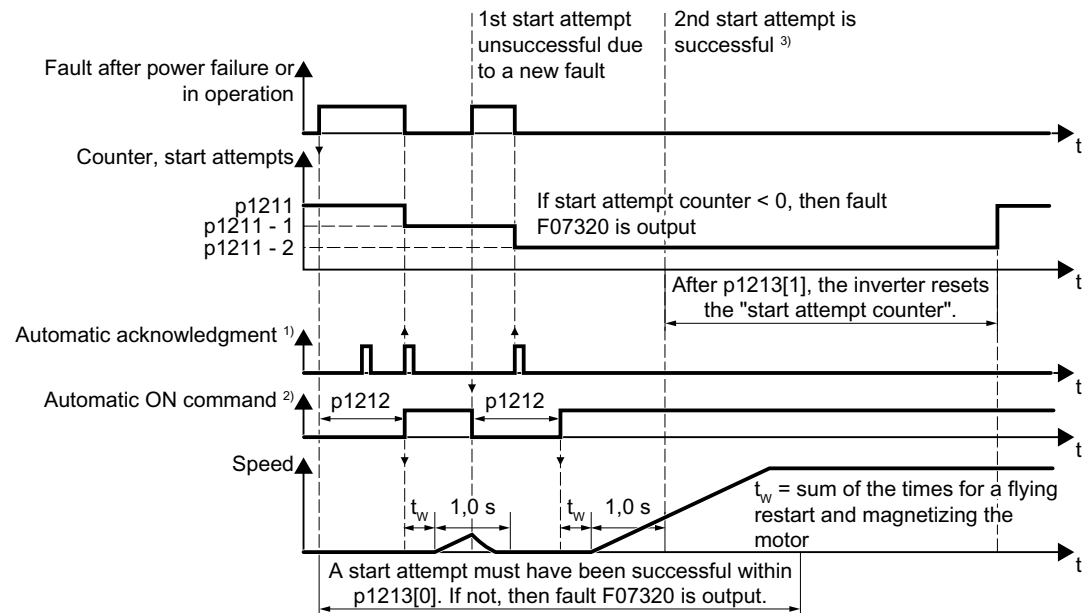

Figure 6-77 Automatic restart modes



The principle of operation of the other parameters is explained in the following diagram and in the table below.



<sup>1)</sup> The converter automatically acknowledges faults under the following conditions:

- p1210 = 1 or 26: Always.
- p1210 = 4 or 6: If the command to switch-on the motor is available at a digital input or via the fieldbus (ON/OFF1 = 1).
- p1210 = 14 or 16: Never.

<sup>2)</sup> The converter attempts to automatically switch the motor on under the following conditions:

- p1210 = 1: Never.
- p1210 = 4, 6, 14, 16, or 26: If the command to switch-on the motor is available at a digital input or via the fieldbus (ON/OFF1 = 1).

<sup>3)</sup> If, after a flying restart and magnetization (r0056.4 = 1) no fault occurs within one second, then the start attempt was successful.

Figure 6-78 Time response of the automatic restart

Further information is provided in the parameter list.

### Advanced settings

If you wish to suppress the automatic restart function for certain faults, then you must enter the appropriate fault numbers in p1206[0 ... 9].

Example: p1206[0] = 07331 ⇒ No restart for fault F07331.

Suppressing the automatic restart only functions for the setting p1210 = 6, 16 or 26.

---

**Note**
**Motor starts in spite of an OFF command via the fieldbus**

The converter responds with a fault if fieldbus communication is interrupted. For one of the settings p1210 = 6, 16 or 26, the converter automatically acknowledges the fault and the motor restarts, even if the higher-level control attempts to send an OFF command to the converter.

- In order to prevent the motor automatically starting when the fieldbus communication fails, you must enter the fault number of the communication error in parameter p1206.
- 

**Parameter**

Number	Name	Factory setting
p1206	Automatic restart faults not active	0
p1210	Automatic restart mode	0
p1211	Automatic restart, start attempts	3
p1212	Automatic restart, wait time start attempts	1 s
p1213[0]	Automatic restart monitoring time for restart	60 s
p1213[1]	Reset automatic restart monitoring time for start-up counter	0 s
p29630	Activate continuous operation	0

### 6.8.3 Kinetic buffering (Vdc min control)

#### Overview



Kinetic buffering increases the drive availability. The kinetic buffering utilizes the kinetic energy of the load to buffer line dips and failures. During a line dip, the converter keeps the motor in the switched-on state for as long as possible. One second is a typical maximum buffer time.

#### Precondition

The following conditions have to be fulfilled to use the "kinetic buffering" function advantageously:

- The driven machine has a sufficiently high inertia.
- The application allows a motor to be braked during a power failure.

#### Function description

When the line supply dips, the DC-link voltage in the converter decreases. The kinetic buffering ( $V_{DC\ min}$  control) intervenes at an adjustable threshold. The  $V_{DC\ min}$  control forces the load to go into slightly regenerative operation. As a consequence, the converter covers its power loss and the losses in the motor with the kinetic energy of the load. The load speed decreases, but the DC-link voltage remains constant during the kinetic buffering. After the line supply returns, the converter immediately resumes normal operation.

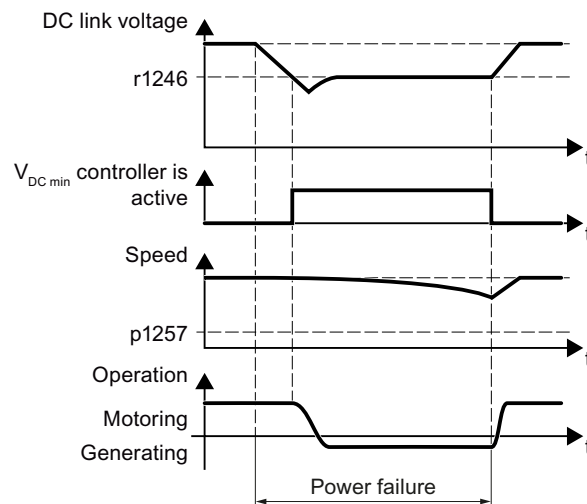

Figure 6-79 Principle mode of operation of kinetic buffering

#### Parameters

Number	Name	Factory setting
r0056[0...15]	CO/BO: Status word, closed-loop control	-
p0210	Device supply voltage	400 V
p1240[D]	Vdc controller configuration (vector control)	1

Number	Name	Factory setting
p1245[D]	Vdc_min controller, switch-on level (kinetic buffering)	See parameter list
r1246	Vdc_min controller, switch-on level (kinetic buffering)	- V
p1247[D]	Vdc_min controller, dynamic factor (kinetic buffering)	300%
p1255[D]	Vdc_min controller, time threshold	0 s
p1257[D]	Vdc_min controller, speed threshold	50 rpm

### 6.8.4 Essential service mode

#### Overview



In essential service mode (ESM), the converter attempts to operate the motor for as long as possible despite irregular ambient conditions.

The converter logs the essential service mode and any faults that occur during essential service mode. The log is accessible only for the service and repair organization.

---

#### Note

##### Warranty is lost in the essential service mode

When the essential service mode is active, and faults occur in the converter, all warranty claims associated with the converter become null and void. The faults can have the following causes:

- Exceptionally high temperatures inside and outside the converter
  - Open fire inside and outside the converter
  - Emissions of light, noise, particles or gases
- 

#### Function description

##### Activating and terminating essential service mode

Signal p3880 = 1 activates the essential service mode.

Signal p3880 = 0 deactivates the essential service mode.

##### Switching the motor on and off during active essential service mode

The OFF1, OFF2 and OFF3 commands for switching off the motor have no effect.

The converter blocks all functions that switch off the motor to save energy, e.g. PROFenergy or hibernation mode.

The "Safe Torque Off" safety function terminates the essential service mode.

 <b>WARNING</b>
<p><b>Unexpected exiting of the essential service mode by selecting "Safe Torque Off"</b></p> <p>An active Safe Torque Off (STO) safety function switches the motor off, thus terminating the essential service mode. The termination of essential service mode can cause severe injury or death, e.g. for the failure of a flue gas extraction.</p> <ul style="list-style-type: none"> <li>• Prevent the STO safety function from being selected in essential service mode by controlling the converter appropriately.</li> <li>• Take the unintentional selection of the STO safety function into account in the risk analysis of the system.</li> </ul>

### Setpoint during active essential service mode

The converter changes the speed setpoint to the ESM setpoint source.

P3881 determines the ESM setpoint source. If you have defined an analog input as setpoint source using p3881, the converter can switch over to setpoint p3882 in case of wire breakage.

### Reaction to faults during active essential service mode

In "essential service mode", the converter does not switch off the motor when faults develop, but rather reacts differently depending on the fault type:

- The converter ignores faults, which do not directly result in the destruction of the converter or the motor.
- Faults with the reaction "OFF2" switch the motor off immediately.  
In this case, the converter attempts to automatically acknowledge the faults using the automatic restart function.
- For faults that cannot be acknowledged, it is possible to switch over the motor to line operation using the bypass function.

### Automatic restart during active essential service mode

The converter ignores the settings in p1206 (faults without automatic restart) and works with the setting "restart after a fault with further start attempts" (p1210 = 6).

The converter carries out the maximum number of restart attempts set in p1211 corresponding to the settings in p1212 and p1213. The converter outputs fault F07320 if the restart attempts are not successful.

### Interaction for bypass and essential service mode

- If the bypass mode is active when the essential service mode is activated, the converter changes to converter mode. This ensures that the converter uses the ESM setpoint source.
- If faults are still present after the number of start attempts parameterized in p1211, then the converter goes into a fault condition with F07320. In this case, there is an option of switching over to bypass operation and then directly connecting the motor to the line supply.

**Procedure: Commissioning the essential service mode**

1. Interconnect a free digital input as signal source for the ESM activation.  
You must use a negated digital input if the essential service mode should also be active for a ground fault – or if the control cable is interrupted.  
Example for negated digital input DI 3: Set p3880 = 723.3.  
It is not permissible to interconnect the digital input for ESM activation with other functions.
2. Set the ESM setpoint source via p3881.
3. Set the alternative ESM setpoint source via p3882.
4. Set the source to select the direction of rotation.
  - p3881 = 0, 1, 2, 3:  
When you interconnect p3883 with a free digital input of your choice, p3883 inverts the direction of rotation during essential service mode.  
For example, to interconnect p3883 with DI 4, set p3883 = 722.4.
  - p3881 = 4:  
The technology setpoint direction of rotation is valid.
5. Optional switching to bypass mode  
If the converter is not able to acknowledge pending faults with automatic restart, it signals fault F07320 and does not make any other attempts to restart.  
If the motor still continues to operate in this case, you must set the following:
  - Set p1266 = 3889.10. The converter switches the motor to bypass mode with r3889.10 = 1.
  - Ensure that the direction of rotation does not change when switching over to bypass operation.
  - Set p1267.0 = 1. The converter switches the motor to bypass mode independent of the speed with control signal p1266.
  - Commission the "Bypass" function.  
 Bypass (Page 354)

You have commissioned the essential service mode.



**Example**

To improve the air circulation in the stairwells, the ventilation control creates an underpressure in the building. With this control, a fire would mean that flue gases enter into the stairwell. This would then mean that the stairs would be blocked as escape or evacuation route.

Using the essential service mode function, the ventilation switches over to the control of an overpressure. The essential service mode prevents the propagation of flue gas in the stairwell, thereby keeping the stairs free as an evacuation route as long as possible.

An application example for the essential service mode can be found on the Internet:

 <http://support.automation.siemens.com/WW/view/en/63969509> (<http://support.automation.siemens.com/WW/view/en/63969509>)

Function diagram

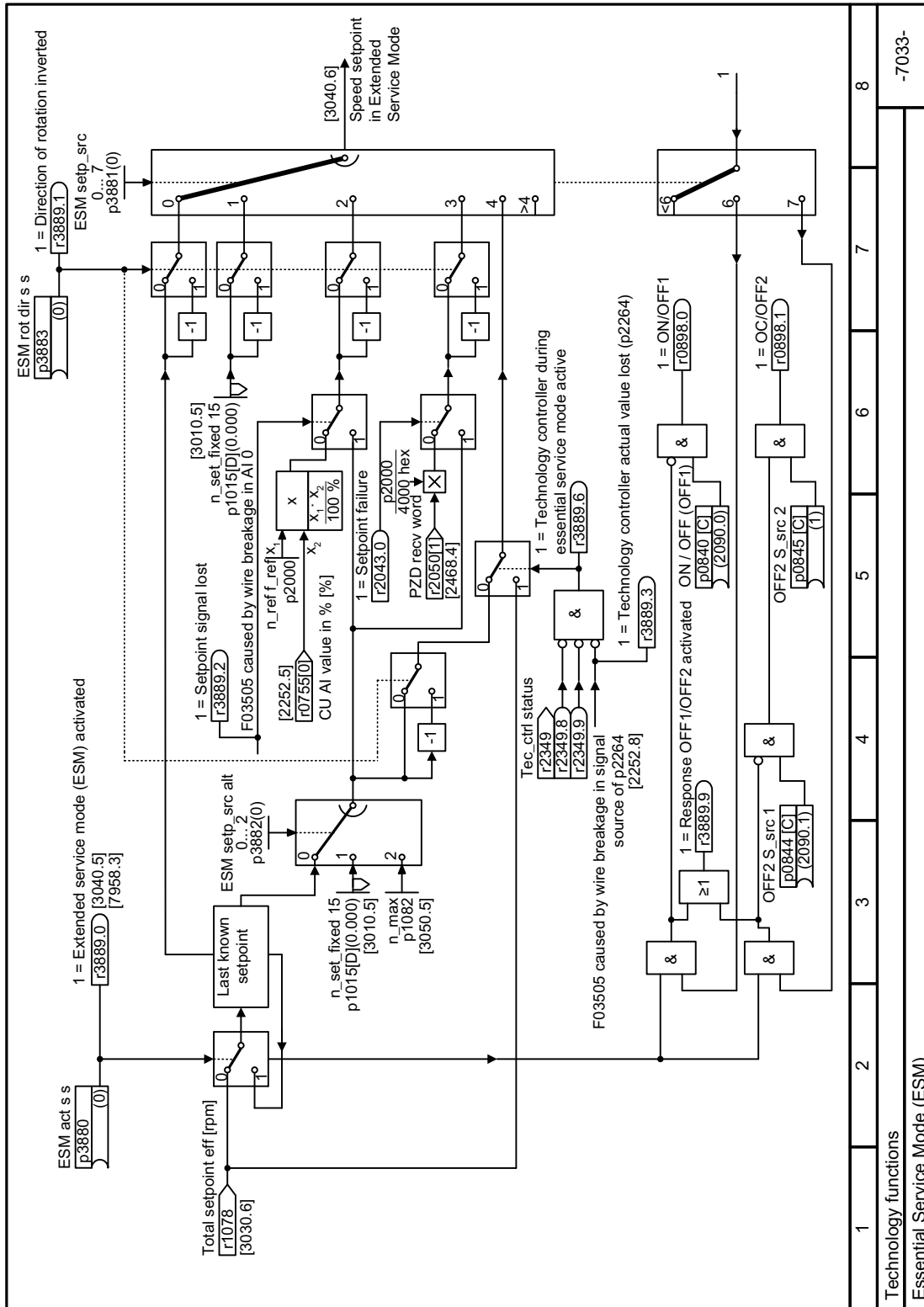

Figure 6-80 FP 7033

**Parameters**

Number	Name	Factory setting
p1206[0...9]	Automatic restart faults not active	0
p1210	Automatic restart mode	0
p1211	Automatic restart, start attempts	3
p1212	Automatic restart, wait time start attempts	1 s
p1213	Automatic restart monitoring time for restart	60 s
p1213	Automatic restart reset monitoring time for start counter	0 s
p1266	BI: Bypass control command	0
p1267	Bypass changeover source configuration	0000 bin
p3880	BI: ESM activation signal source	0
p3881	ESM setpoint source	0
p3882	ESM alternative setpoint source	0
p3883	BI: ESM direction of rotation signal source	0
p3884	CI: ESM technology controller setpoint	0
r3889[0...10]	CO/BO: ESM status word	-



## 6.9 Energy saving

### 6.9.1 Efficiency optimization

#### Overview



The efficiency optimization reduces the motor losses as far as possible.

Active efficiency optimization has the following advantages:

- Lower energy costs
- Lower motor temperature rise
- Lower motor noise levels

Active efficiency optimization has the following disadvantage:

- Longer acceleration times and more significant speed dips during torque surges.

The disadvantage is only relevant when the motor must satisfy high requirements relating to the dynamic performance. Even when efficiency optimization is active, the converter closed-loop motor control prevents the motor from stalling.

#### Precondition

Efficiency optimization functions under the following preconditions:

- Operation with an induction motor
- Vector control is set in the converter.

#### Function description

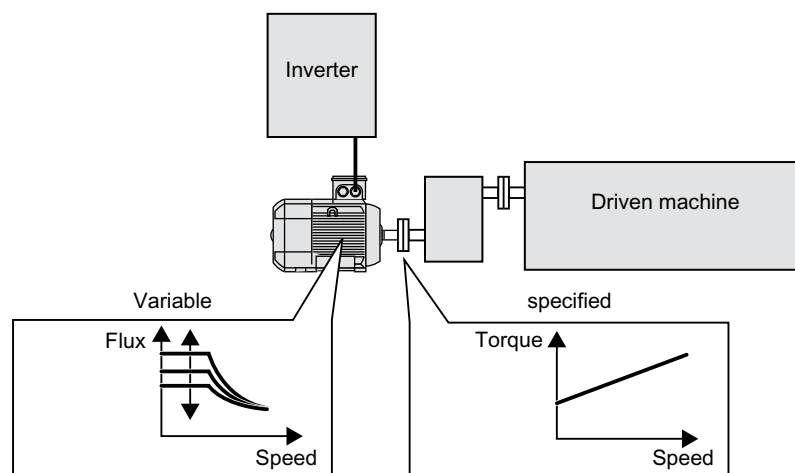

Figure 6-81 Efficiency optimization by changing the motor flux

The three variables that the converter can directly set, which define efficiency of an induction motor, are speed, torque and flux.

However, in all applications, speed and torque are specified by the driven machine. As a consequence, the remaining variable for the efficiency optimization is the flux.

The converter has two different methods of optimizing the efficiency.

**Efficiency optimization, method 2**

Generally, energy efficiency optimization method 2 achieves a better efficiency than method 1.

We recommend that you set method 2.

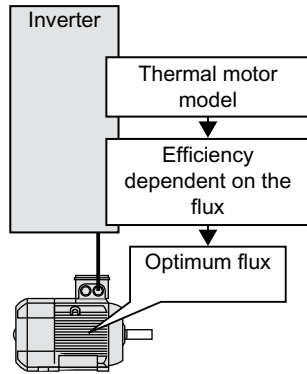
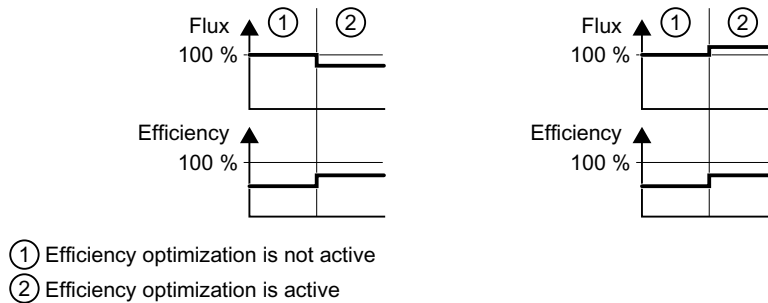

Figure 6-82 Determining the optimum flux from the motor thermal model

Based on its thermal motor model, the converter continually determines - for the actual operating point of the motor - the interdependency between efficiency and flux. The converter then sets the flux to achieve the optimum efficiency.



- ① Efficiency optimization is not active
- ② Efficiency optimization is active

Figure 6-83 Qualitative result of efficiency optimization, method 2

Depending on the motor operating point, the converter either decreases or increases the flux in partial load operation of the motor.

### Efficiency optimization, method 1

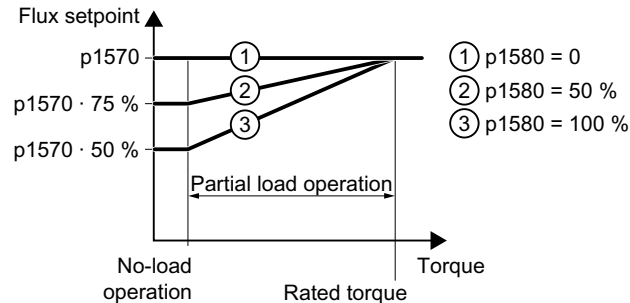

Figure 6-84 Reduce the flux setpoint in the partial load range of the motor

The motor operates in partial load mode between no-load operation and the rated motor torque. Depending on p1580, in the partial load range, the converter reduces the flux setpoint linearly with the torque.

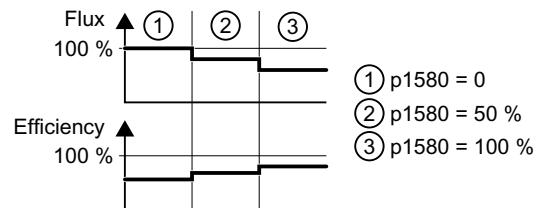

Figure 6-85 Qualitative result of efficiency optimization, method 1

The reduced flux in the motor partial load range results in higher efficiency.

## Parameters

The converter calculates the parameters for the thermal motor model based on the motor data that has been set – and the motor data identification.

Table 6-73 Efficiency optimization, method 2

Number	Name	Factory setting
p1401[D]	Flux control configuration	0000 0000 0000 0110 bin
p1570[D]	CO: Flux setpoint	100%
p3315[D]	Efficiency optimization 2 minimum flux limit value	50%
p3316[D]	Efficiency optimization 2 maximum flux limit value	110 %

Table 6-74 Efficiency optimization, method 1

Number	Name	Factory setting
p1570[D]	CO: Flux setpoint	100%
p1580[D]	Efficiency optimization	80%

## 6.9.2 Bypass

### Overview



The "Bypass" function switches the motor between converter and line operation.

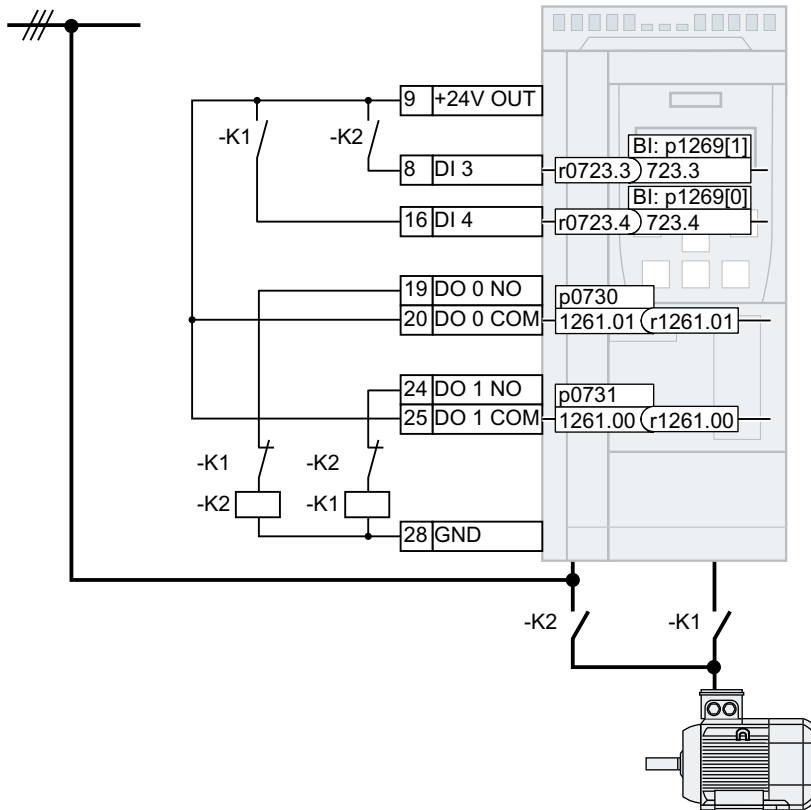

Figure 6-86 Bypass control via converter

Requirements placed on the K1 converter contactor and K2 line contactor:

- K1 and K2 are designed for switching under load.
- K2 is designed for switching an inductive load.
- K1 and K2 are interlocked against closing at the same time.

### Preconditions

- The "Bypass" function is supported only for induction motors.
- The "Flying restart" function must be activated for the "Bypass" function (p1200 = 1 or 4).  
 Flying restart – switching on while the motor is running (Page 340)

## Function description

### Switching from converter operation to line operation

1. The converter switches the motor OFF.
2. The converter opens the K1 converter contactor via a digital output.
3. The converter waits for the unlocking time of the motor.
4. The converter waits for the feedback that the K1 converter contactor is open.
5. The converter closes the K2 line contactor via a digital output.

The motor is now operated directly on the line supply.

---

### Note

#### Current surge when switching from converter operation to line operation

When switching from converter operation to line operation, a current  $> 10 \times$  rated motor current can flow temporarily. The current depends on the random phase shift between the converter voltage and the line voltage.

---

### Switching from line operation to converter operation

1. The converter opens the K2 line contactor via a digital output.
2. The converter waits for the unlocking time of the motor.
3. The converter waits for the feedback that the K2 line contactor is open.
4. The converter closes the K1 converter contactor via a digital output.
5. The converter switches the motor on.
6. The converter adjusts with the "Flying restart" function its output frequency to the speed of the motor.

The motor is now operated on the converter.

### How is the changeover triggered?

The following options are provided to switch between converter operation and line operation:

- Changeover for activation via a control command

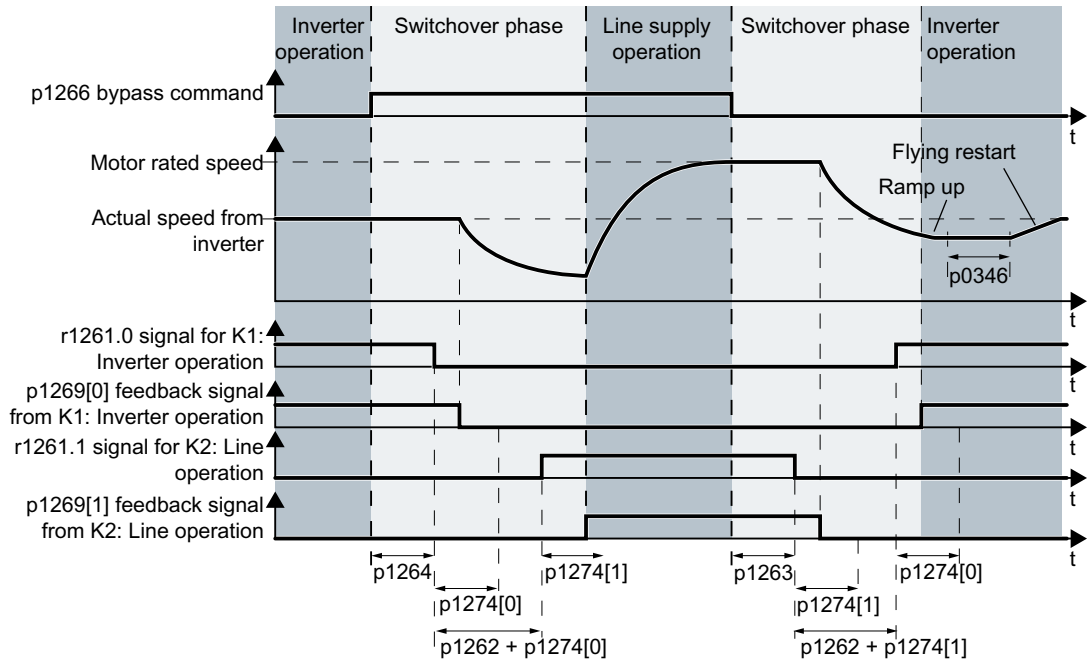

Figure 6-87 Changeover when activating via a control signal (p1267.0 = 1)

The converter switches the motor between converter operation and line operation depending on the bypass control command p1266.

- Changeover depending on the speed

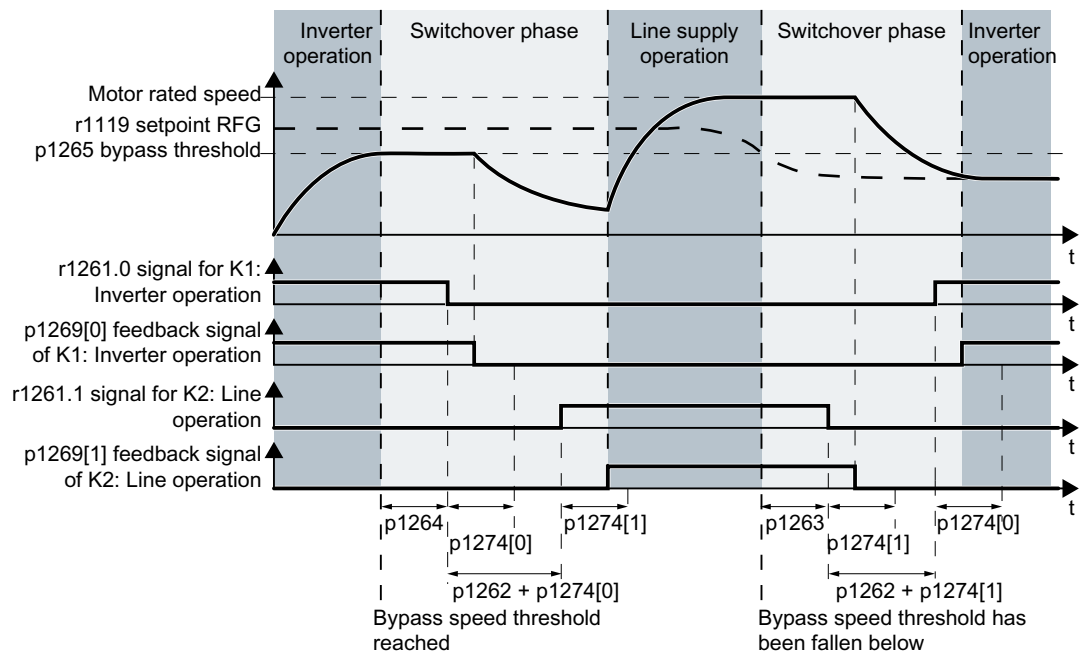

Figure 6-88 Changeover depending on the speed (p1267.1 = 1)

If the speed setpoint r1119 lies above the bypass speed threshold p1265, the converter switches the motor to line operation.

If the speed setpoint falls below the bypass speed threshold, the converter switches the motor to converter operation.

Function diagram

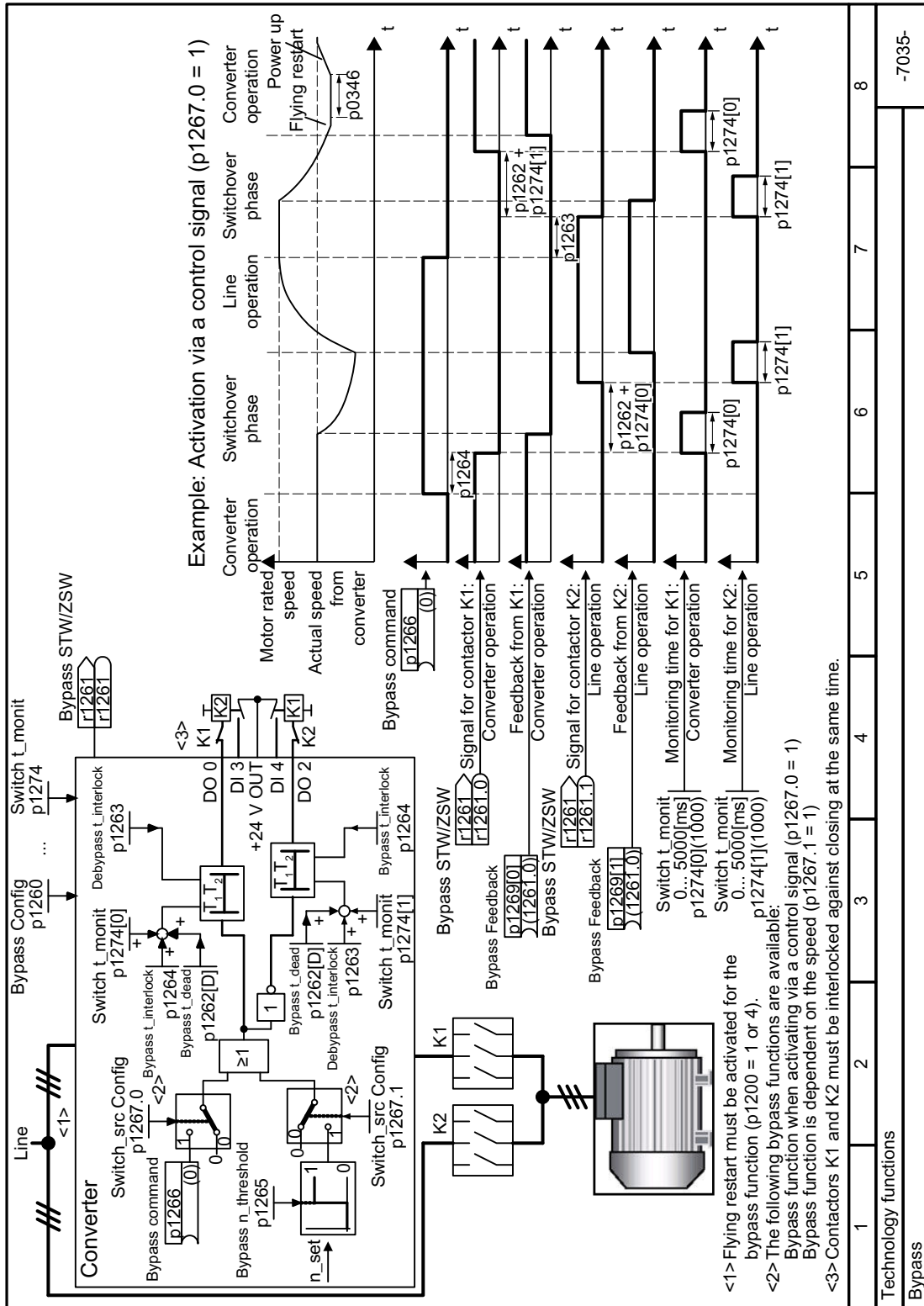

Figure 6-89 FP 7035



## Parameters



Number	Name	Factory setting
p0347[M]	Motor de-excitation time	0 s
p1260	Bypass configuration (factory setting: 0) 0: Bypass is deactivated 3: Bypass without synchronization	0
r1261	Bypass control/status word	-
p1262[D]	Bypass dead time	1 s
p1263	Debypass (revert to drive) delay time	1 s
p1264	Bypass delay time	1 s
p1265	Bypass speed threshold	1480 rpm
p1266	BI: Bypass control command	0
p1267	Bypass changeover source configuration	0000 bin
p1269	BI: Bypass switch feedback signal	[0] 1261.0 [1] 1261.1
p1274[0...1]	Bypass switch monitoring time	1000 ms

Further information is provided in the parameter list.

 Parameters (Page 373)

## More information

Interaction with other functions:

- Essential service mode  
The activated "Essential service mode" function influences the "Bypass" function.  
 Essential service mode (Page 346)
- Converter control  
For operation of the motor on the line supply, the converter no longer responds to the OFF1 command, but rather only to OFF2 and OFF3.
- Temperature monitoring for the motor  
The converter evaluates the temperature sensor in the motor, also for line operation of the motor.  
 Motor protection with temperature sensor (Page 327)
- Disconnecting the converter from the line supply  
If for line operation of the motor, you disconnect the converter from the line supply, the converter opens the K2 contactor and the motor coasts down.  
To operate the motor on the line supply also for deactivated converter, the higher-level control must supply the signal for the K2 line contactor.

### 6.9.3 Hibernation mode



The hibernation mode saves energy, reduces mechanical wear and noise.

Pressure and temperature controls involving pumps and fans are typical applications for the hibernation mode.

#### Function

If the plant/system conditions permit it, the converter switches off the motor and switches it on again when there is a demand from the process.

The hibernation mode starts as soon as the motor speed drops below the hibernation mode start speed. The converter switches off the motor after an adjustable time. If, during this time, the speed setpoint increases above the hibernation mode start speed due to pressure or temperature changes, the converter exits the hibernation mode.

In the hibernation mode the motor is switched off, but the converter continues to monitor the speed setpoint or technology controller deviation.

- **For an external setpoint input (without technology controller), the converter monitors the speed setpoint** and switches on the motor again as soon as the setpoint increases above the restart speed.  
In the factory setting, the converter monitors the positive speed setpoint. The converter switches on the motor as soon as the setpoint exceeds the restart speed.  
If you also want to monitor the negative speed setpoint, you have to monitor the setpoint amount. To do this, set  $p1110 = 0$ .
- **When the setpoint is input from the technology controller, the converter monitors the technology controller deviation (r2273)** and switches on the motor again if the deviation of the technology controller exceeds the hibernation mode restart value ( $p2392$ ).  
In the factory setting, the converter monitors the positive deviation of the technology controller. The converter switches on the motor as soon as the technology controller deviation is higher than the hibernation mode restart value ( $p2392$ ).  
You must monitor the absolute value of the deviation to switch on the motor again for a negative technology controller deviation.  
Set  $p2298 = 2292$  and set the minimum threshold in  $p2292$ .

---

#### Note

##### Hibernation mode after switching on the converter

After switching the converter on, a wait time starts in the converter. The longest wait time is at the following times:

- $p1120$  (ramp-up time)
- $p2391$  (hibernation mode delay time)
- 20 s

If the motor does not reach the hibernation mode start speed within this wait time, the converter activates the hibernation mode and switches off the motor.

---

If you want to prevent frequent activation and deactivation, before deactivation you still have to set a short speed boost. The boost is deactivated with  $p2394 = 0$ .

To avoid tank deposits, particularly where liquids are involved, it is possible to exit the hibernation mode after an adjustable time (p2396) has expired and switch to normal operation.

The settings required for the respective variant can be found in the following tables.

### Interaction of the function with the cascade control

It is not possible to activate the hibernation mode as long as a motor is directly operated from the line supply using the cascade control function.

 Cascade control (Page 287)

### Activating the hibernation mode with setpoint input via the internal technology controller

With this operating mode you have to set the technology controller as the setpoint source (p2200) and use the output of the technology controller as the main setpoint (p2251). The boost can be deactivated.

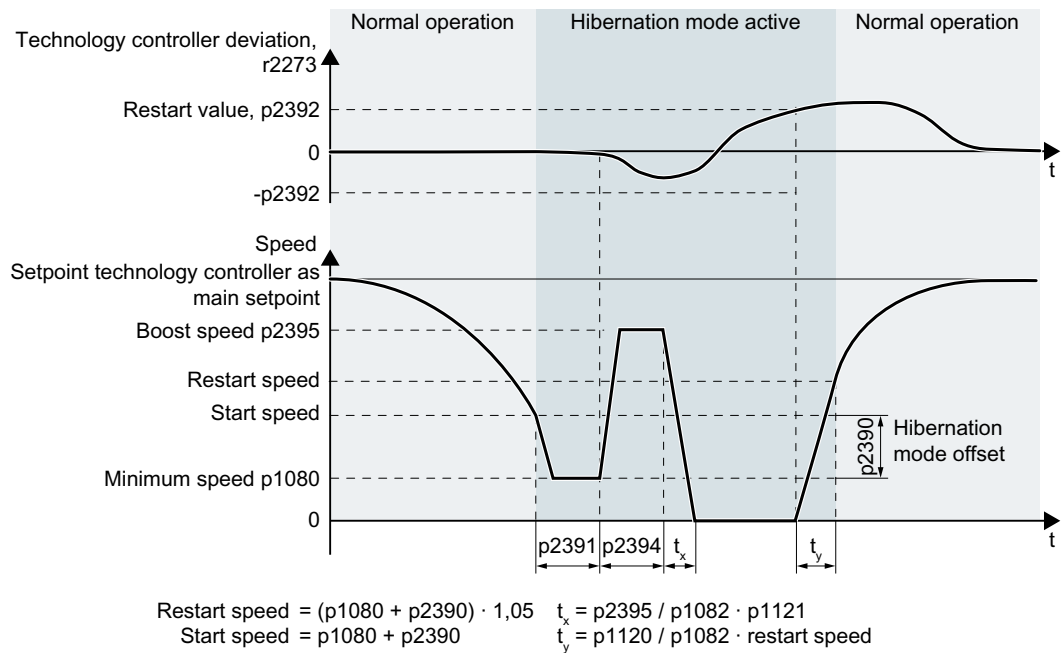
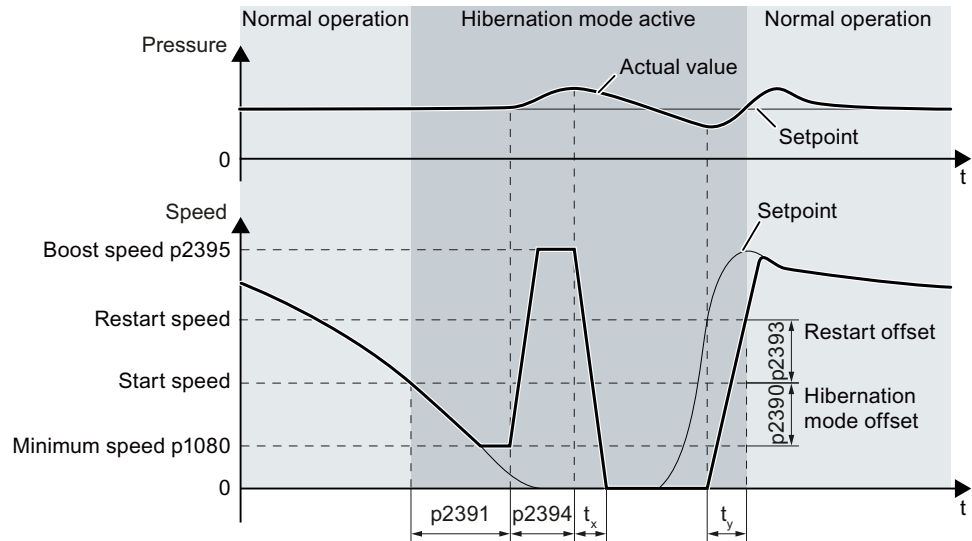

Figure 6-90 Hibernation mode using the technology setpoint as main setpoint with boost

### Activating the hibernation mode with external setpoint input

With this operating mode, an external source – e.g. a temperature sensor – inputs the main setpoint.



$$\begin{aligned} \text{Restart speed} &= p1080 + p2390 + p2393 & t_x &= p2395 / p1082 * p1121 \\ \text{Start speed} &= p1080 + p2390 & t_y &= \text{restart speed} / p1082 * p1120 \end{aligned}$$

Figure 6-91 Hibernation mode using an external setpoint with boost

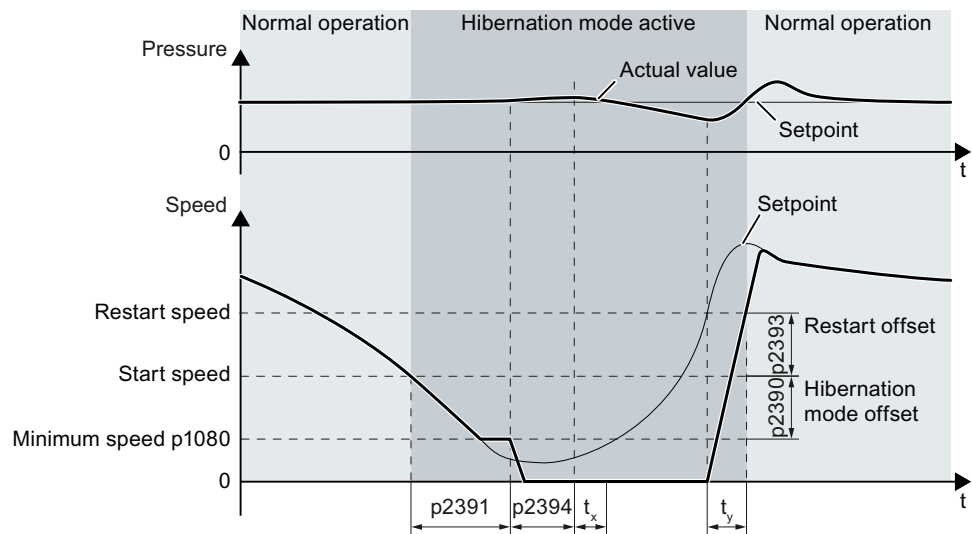

$$\begin{aligned} \text{Restart speed} &= p1080 + p2390 + p2393 & t_x &= p2395 / p1082 * p1121 \\ \text{Start speed} &= p1080 + p2390 & t_y &= \text{restart speed} / p1082 * p1120 \end{aligned}$$

Figure 6-92 Hibernation mode using an external setpoint without boost

## Setting the hibernation mode

Number	Name	Via tech. setpoint	Via external setpoint
p1080	<b>Minimum speed</b> 0 (factory setting) ... 19,500 rpm. Lower limit of the motor speed, independently of the speed target value.	✓	✓
p1110	<b>Block negative direction</b> Parameter to block the negative direction	-	✓
p2200	<b>Technology controller enable</b> 0: Technology controller deactivated (factory setting), 1: Technology controller activated	✓	-
p2251 = 1	<b>Technology controller mode</b> 0: Technology controller as main setpoint (factory setting), 1: Technology controller as supplementary setpoint	✓	-
p2298	<b>Technology controller minimum limiting</b> Parameter for the minimum limiting of the technology controller	✓	-
p2398	<b>Hibernation mode</b> 0: Hibernation mode inhibited (factory setting) 1: Hibernation mode enabled	✓	✓
p2390	<b>Hibernation mode start speed</b> 0 (factory setting) ... 21,000 rpm. As soon as this speed is fallen below, the hibernation mode delay time starts and switches off the motor once it expires. The hibernation mode start speed is calculated as follows: Start speed = p1080 + p2390 p1080 = minimum speed p2390 = hibernation mode start speed	✓	✓
p2391	<b>Hibernation mode delay time</b> 0 ... 3599 s (factory setting 120). The hibernation mode delay time starts as soon as the output frequency of the converter drops below the hibernation mode start speed p2390. If the output frequency increases above this threshold during the delay time, the hibernation mode delay time is interrupted. Otherwise, the motor is switched off after the delay time has expired (if necessary, after a short boost).	✓	✓
p2392	<b>Hibernation mode restart value (as a %)</b> Is required if the technology controller is used as the main setpoint. As soon as the technology controller deviation (r2273) exceeds the hibernation restart value, the converter switches to normal operation and the motor starts up with a setpoint of $1.05 * (p1080 + p2390)$ . As soon as this value is reached, the motor continues to operate with the setpoint of the technology controller (r2260).	✓	-

Number	Name	Via tech. setpoint	Via external setpoint
p2393	<p><b>Hibernation mode restart speed (rpm)</b>                      Required for external setpoint input. The motor starts as soon as the setpoint exceeds the restart speed. The restart speed is calculated as follows:                      Restart speed = p1080 + p2390 + p2393                      p1080 = minimum speed                      p2390 = hibernation mode start speed                      p2393 = hibernation mode restart speed</p>	-	✓
p2394	<p><b>Hibernation mode boost duration</b>                      0 (factory setting) ... 3599 s. Before the converter switches over into the hibernation mode, the motor is accelerated for the time set in p2394 according to the acceleration ramp, however, as a maximum to the speed set in p2395.</p>	✓	✓
p2395	<p><b>Hibernation mode boost speed</b>                      0 (factory setting) ... 21,000 rpm. Before the converter switches over to hibernation mode, the motor is accelerated for the time set in p2394 along the acceleration ramp, but not to more than the speed set in p2395.   <b>Caution:</b>                      The boost may not result in any overpressure or overrun.</p>	✓	✓
p2396	<p><b>Maximum hibernation mode shutdown time</b>                      0 (factory setting) to 863,999 s. At the latest when this time expires, the converter switches to normal operation and accelerates up to the start speed (p1080 + p2390). If the converter is switched to normal operation in advance, the shutdown time is reset to the value set in this parameter.                      With p2396 = 0, automatic changeover to normal operation after a certain time is deactivated.</p>	✓	✓

**Note**

Activate the motorized potentiometer as ramp-function generator to use the motorized potentiometer of the converter as setpoint for the hibernation mode.

- Motorized potentiometer: p1030.4 = 1
- Technology motorized potentiometer: p2230. = 1.

## Status of the hibernation mode

Number	Name
r2273	<b>Display of the setpoint/actual value deviation of the technology controller</b>
r2397	<b>Actual hibernation mode output speed</b> Actual boost speed before the pulses are inhibited or the actual start speed after restart.
r2399	<b>Hibernation mode status word</b> 00 Hibernation mode enabled (p2398 <> 0) 01 Hibernation mode active 02 Hibernation mode delay time active 03 Hibernation mode boost active 04 Hibernation mode motor switched off 05 Hibernation mode motor switched off, cyclic restart active 06 Energy-saving mode motor restarts 07 Hibernation mode supplies the total setpoint of the ramp-function generator 08 Hibernation mode bypasses the ramp-function generator in the setpoint channel

### 6.9.4 Line contactor control

#### Overview



A line contactor disconnects the converter from the line supply, and therefore reduces the converter losses when the motor is not operational.

#### Function description

The converter controls its own line contactor using a digital output. The line contactor control requires a 24 V power supply from the converter. The 24 V power supply must be maintained even when the line contactor is open.

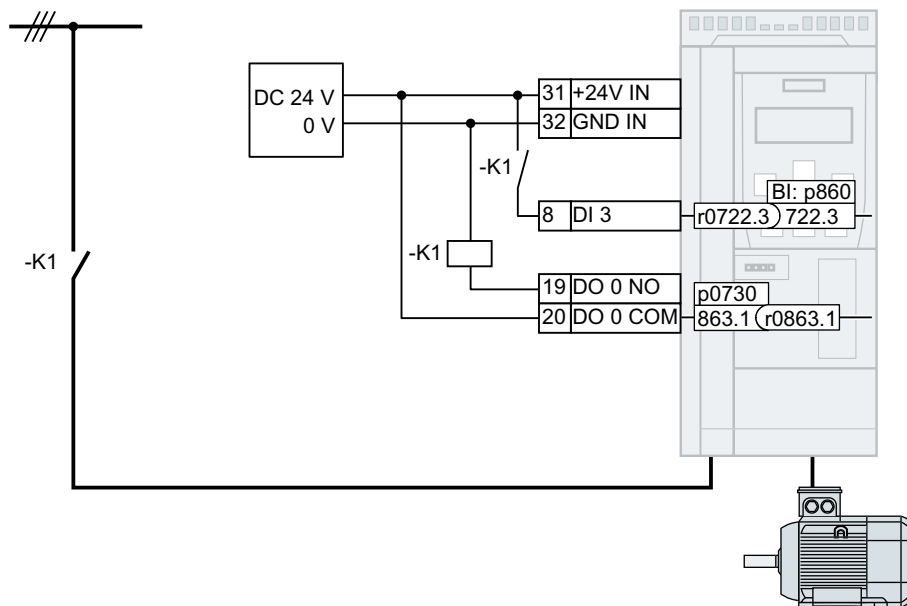

Figure 6-93 Line contactor control via DO 0 with feedback signal via DI 3

#### Activating the line contactor control

In order for the converter to control line contactor K1 using one of its own digital outputs, you must interconnect the digital output with signal r0863.1, e.g. for DO 0: p0730 = 863.1.

#### Line contactor control with feedback signal

Interconnect p0860 with the signal of the corresponding digital input:

- p0860 = 722.x: Feedback signal of an NO contact via DIx
- p0860 = 723.x: Feedback signal of an NC contact via DIx

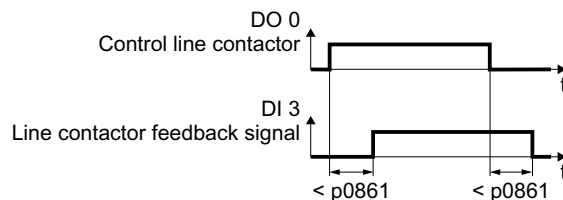



Figure 6-94 Line contactor control via DO 2 with feedback signal via DI 3

If the line contactor feedback signal is not available for longer than the time set in p0861, the converter signals fault F07300.

## Parameters

Number	Name	Factory setting
r0046.0...n	CO/BO: Missing enable signals	-
p0860	BI: Line contactor feedback signal	863.1
p0861	Line contactor monitoring time	100 ms
r0863.0...1	CO/BO: Drive coupling status word / control word	-
p0867	Power unit main contactor hold time after OFF1	50 ms
p0869	Configuration sequence control	0000 bin
p0870	BI: close main contactor	0

More information is provided in the parameter list.

### 6.9.5 Calculating the energy saving for fluid flow machines

#### Overview



Fluid flow machines, which mechanically control the flow rate using valves or throttle flaps, operate with a constant speed corresponding to the line frequency.



Figure 6-95 Flow control with pump and throttle connected to a 50 Hz line supply

The lower the flow rate, the poorer the efficiency of the fluid flow machine (pump). The fluid flow machine (pump) has the poorest efficiency when the throttle or valve is completely closed. Further, undesirable effects can occur, for example the formation of vapor bubbles in liquids (cavitation) or the temperature of the medium being pumped can increase.

The converter controls the flow rate by appropriately varying the speed of the fluid flow machine. By controlling the flow rate, the fluid flow machine operates at the optimum efficiency for each flow rate. This situation means that in the partial load range less electric power is required than when controlling the flow rate using valves and throttles.

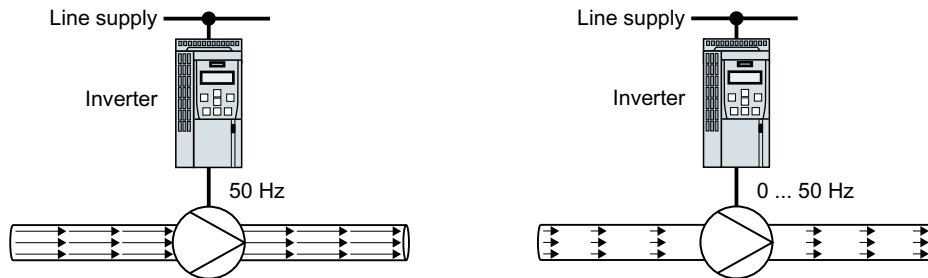
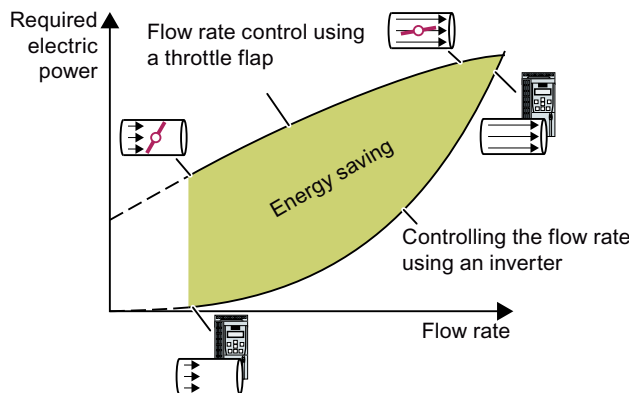

Figure 6-96 Flow control with pump and converter

#### Function description



The converter calculates the energy saving from the flow characteristic associated with a mechanical flow control and the measured electric power that is drawn.

The calculation is suitable for centrifugal pumps, fans, radial and axial compressors, for instance.

### Flow characteristic

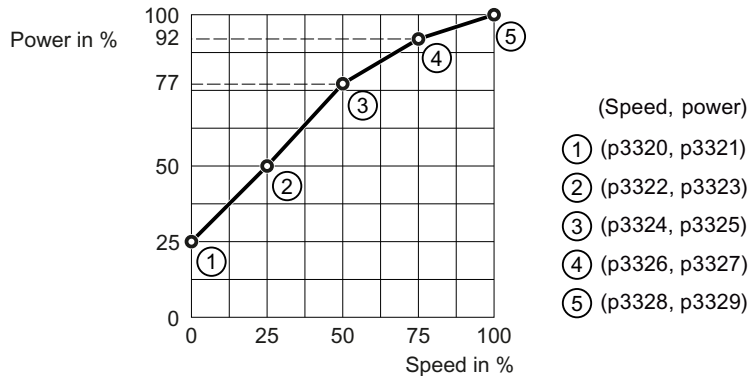

Figure 6-97 Factory setting of the flow characteristic

To set the characteristic, you require the following data from the machine manufacturer for each speed interpolation point:

- The flow rate of the fluid-flow machine associated with the 5 selected converter speeds
- At constant speed, the power drawn which is associated with the 5 flow rates corresponds to the line frequency and mechanical throttling of the flow rate.

### Parameters

Number	Name	Factory setting
r0039[0...n]	CO: Energy display	-
p0040	Reset energy consumption display	0
r0041	Energy saved	-
r0042[0...n]	CO: Process energy display	-
p0043	BI: Energy consumption display enabled.	0
p3320[0...n]	Fluid flow machine power, point 1	25
p3321[0...n]	Fluid flow machine speed, point 1	0
p3322[0...n]	Fluid flow machine power, point 2	50
p3323[0...n]	Fluid flow machine speed, point 2	25
p3324[0...n]	Fluid flow machine power, point 3	77
p3325[0...n]	Fluid flow machine speed, point 3	50
p3326[0...n]	Fluid flow machine power, point 4	92
p3327[0...n]	Fluid flow machine speed, point 4	75
p3328[0...n]	Fluid flow machine power, point 5	100
p3329[0...n]	Fluid flow machine speed, point 5	100

## 6.10 Switchover between different settings

### Overview

There are applications that require different converter settings.

**Example:**

Different motors are operated on one converter. The converter must operate with the motor data of the particular motor and the appropriate ramp-function generator.

### Function description

**Drive Data Sets (DDS)**

Some converter functions can be set differently, and there can be a switch between the different settings.

**Note**

You can only switch over the motor data of the drive data sets in the "ready for operation" state with the motor switched off. The switchover time is approx. 50 ms.

If you do not switch over the motor data together with the drive data sets (i.e. same motor number in p0826), then the drive data sets can also be switched over in operation.

The associated parameters are indexed (index 0, 1, 2, or 3). One of the four indexes is selected with control commands, and thereby one of the four saved settings.

The settings in the converter with the same index are called a drive data set.

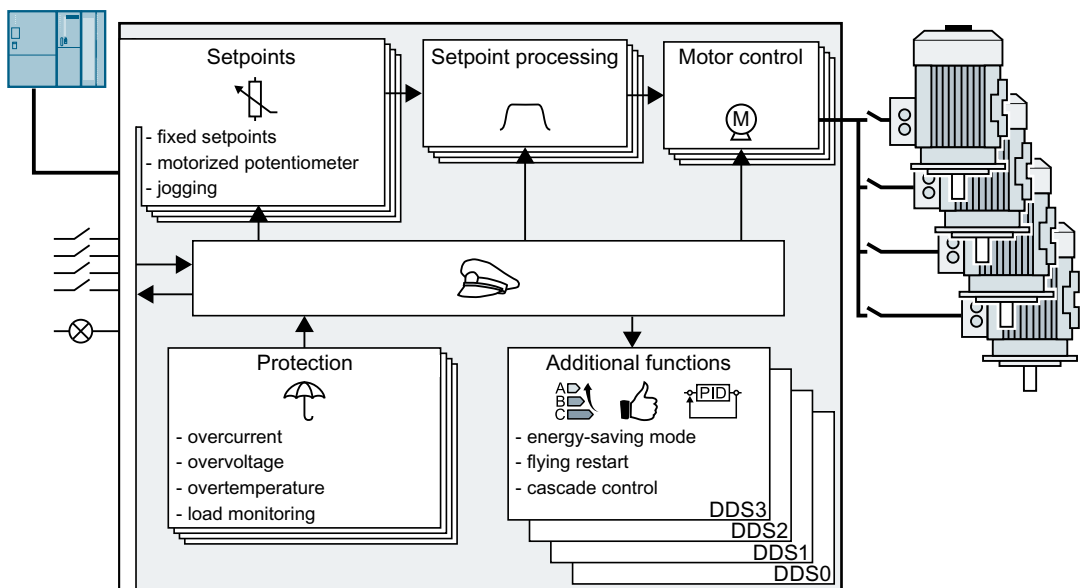

**Selecting the number of drive data sets**

Parameter p0180 defines the number of drive data sets (1 ... 4).

Parameter	Description
p0010 = 0	Drive commissioning: Ready
p0010 = 15	Drive commissioning: Data sets
p0180	Drive data set (DDS) number

**Copying the drive data sets**

Parameter	Description
p0819[0]	Source drive data set
p0819[1]	Target drive data set
p0819[2] = 1	Starts the copy operation

**Parameters**

Number	Name	Factory setting
p0010	Drive commissioning parameter filter	1
r0051	CO/BO: Drive data set DDS effective	-
p0180	Drive data set (DDS) number	1
p0819[0 ... 2]	Copy drive data set DDS	0
p0820[C]	BI: Drive data set DDS selection, bit 0	0
p0821[C]	BI: Drive data set DDS selection, bit 1	0
p0826[M]	Motor changeover, motor number	0



## Parameters

### 7.1 Brief description of the parameters

#### Overview

The brief parameter description provides the most important information for all of the parameters that are assigned to a certain converter function.

If the number of parameter indices depends on the data sets, then the parameter index is shown in an abbreviated form.

Number of indices = number of command data sets (CDS)  
 Number of indices = number of drive data sets (DDS)  
 Number of indices = number of motor data sets (MDS)  
 Parameters with indices 0...3  
 Parameters with bits 0...15

Number	Name	Factory setting
p1234[C]		
p1234[D]		
p1234[M]		
p1234[0...3]		
p1234.0...15		

Figure 7-1 Brief parameter description

## 7.2 Explanation of the detailed parameter list

### Overview

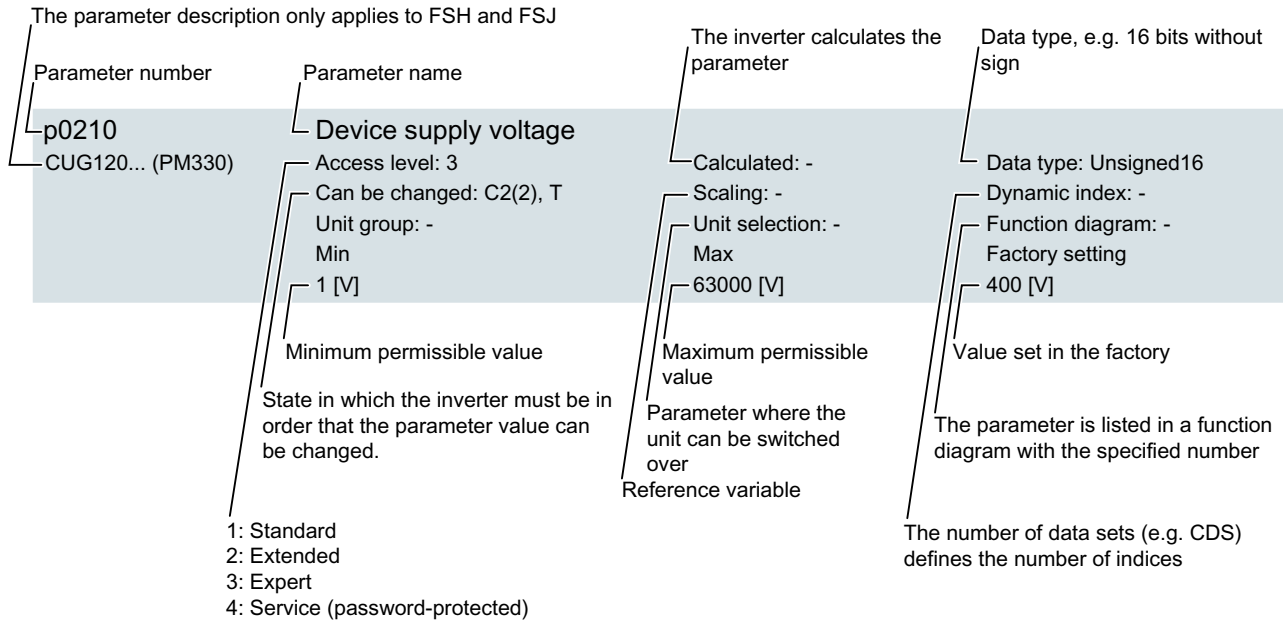

Figure 7-2 Parameter description

### Function description

#### Parameter number

The parameter number is made up of a "p" or "r", followed by a number and optionally the index or bit array.

- p1234                      Adjustable parameters (read and write)
- r1234                      Display parameters (read-only)
- p1234[0...2]              Adjustable parameters with index 0 to 2
- p1234.0 ... 15            Adjustable parameters with bit 0 to bit 15
  
- p1234[1]                    Adjustable parameter index 1
- p1234.1                    Adjustable parameter bit 1

#### Parameter name

The following abbreviations can appear in front of the names:

- BI              Binector input
- BO              Binector output
- CI              Connector input



CO Connector output  
 CO/BO Connector/binector output



Interconnecting signals in the converter (Page 930)

### Can be changed

"-" The parameter can be changed in any state, and the change becomes immediately effective.  
 C(x) The parameter can only be changed for the following settings:  
 C: p0010 > 0  
 C(x): p0010 = x  
 U The motor is switched on  
 T The motor is switched off and p0010 = 0

### Unit group and unit selection

For parameters where the unit can be switched over.

"Unit group": to which group does the parameter belong?

"Unit selection": with which parameter do you switch over the unit?

### Data type

- Integer8 I8 8-bit integer
- Integer16 I16 16-bit integer
- Integer32 I32 32-bit integer
- Unsigned8 U8 8-bit without sign
- Unsigned16 U16 16-bit without sign
- Unsigned32 U32 32-bit without sign
- FloatingPoint32 Float 32-bit floating-point number

### Scaling

Specification of the reference variable with which a signal value is automatically converted with a BICO interconnection.

The following reference variables are available:

- p2000 ... p2003: Reference speed, reference voltage, etc.
- PERCENT: 1.0 = 100%
- 4000H: 4000 hex = 100 % (word) or 4000 0000 hex = 100 % (double word)

### More information

Firmware version: V1.00

Firmware version of the basic system V04712502\_1000100

## 7.3 Parameter list

All objects: CUG120X\_PN

<b>r0002</b>	<b>Drive operating display / Drv op_display</b>	<b>Access level:</b> 2	<b>Calculated:</b> -	<b>Data type:</b> Integer16
		<b>Can be changed:</b> -	<b>Scaling:</b> -	<b>Dynamic index:</b> -
		<b>Unit group:</b> -	<b>Unit selection:</b> -	<b>Function diagram:</b> -
		<b>Min:</b> 0	<b>Max:</b> 200	<b>Factory setting:</b> -
<b>Description:</b>	Operating display for the drive.			
<b>Value:</b>	0: Operation - everything enabled 10: Operation - set "enable setpoint" = "1" (p1142) 12: Operation - RFG frozen, set "RFG start" = "1" (p1141) 13: Operation - set "enable RFG" = "1" (p1140) 14: Operation - MotID, excitation running 16: Operation - withdraw braking with OFF1 using "ON/OFF1" = "1" 17: Operation - braking with OFF3 can only be interrupted with OFF2 18: Operation - brake on fault, remove fault, acknowledge 19: Operation - DC braking active (p1230, p1231) 21: Ready for operation - set "Enable operation" = "1" (p0852) 22: Ready for operation - de-magnetizing running (p0347) 31: Ready for switching on - set "ON/OFF1" = "0/1" (p0840) 35: Switching on inhibited - carry out first commissioning (p0010) 41: Switching on inhibited - set "ON/OFF1" = "0" (p0840) 42: Switching on inhibited - set "OC/OFF2" = "1" (p0844, p0845) 43: Switching on inhibited - set "OC/OFF3" = "1" (p0848, p0849) 44: Switching on inhibited - supply STO terminal w/ 24 V (hardware) 45: Switching on inhibited - remove fault, acknowledge fault 46: Switching on inhibited - exit commissioning mode (p0010) 70: Initialization 200: Wait for booting/partial booting			
<b>Dependency:</b>	See also: r0046			

### NOTICE

For several missing enable signals, the corresponding value with the highest number is displayed.

### Note

OC: Operating condition  
 RFG: Ramp-function generator  
 COMM: Commissioning  
 MotID: Motor data identification

<b>p0003</b>	<b>Access level / Acc_level</b>	<b>Access level:</b> 1	<b>Calculated:</b> -	<b>Data type:</b> Integer16
		<b>Can be changed:</b> C1, T, U	<b>Scaling:</b> -	<b>Dynamic index:</b> -
		<b>Unit group:</b> -	<b>Unit selection:</b> -	<b>Function diagram:</b> -
		<b>Min:</b> 3	<b>Max:</b> 4	<b>Factory setting:</b> 3
<b>Description:</b>	Sets the access level to read and write parameters.			
<b>Value:</b>	3: Expert			

4: Service

**Note**

A higher set access level also includes the lower one.

Access level 3 (experts):

Expert know-how is required for these parameters (e.g. BICO parameterization).

Access level 4 (service):

For these parameters, it is necessary that authorized service personnel enter the appropriate password (p3950).

**p0010****Drive commissioning parameter filter / Drv comm. par\_filt**

**Access level:** 1

**Calculated:** -

**Data type:** Integer16

**Can be changed:** C2(1), T

**Scaling:** -

**Dynamic index:** -

**Unit group:** -

**Unit selection:** -

**Function diagram:** 2800, 2818

**Min:**

**Max:**

**Factory setting:**

0

49

1

**Description:**

Sets the parameter filter to commission a drive.

Setting this parameter filters out the parameters that can be written into in the various commissioning steps.

**Value:**

0: Ready  
 1: Quick commissioning  
 2: Power unit commissioning  
 3: Motor commissioning  
 5: Technological application/units  
 15: Data sets  
 29: Only Siemens internal  
 30: Parameter reset  
 39: Only Siemens internal  
 49: Only Siemens internal

**Dependency:**

See also: r3996

**NOTICE**

When the parameter is reset to a value of 0, short-term communication interruptions may occur.

**Note**

The drive can only be switched on outside the drive commissioning (inverter enable). To realize this, this parameter must be set to 0.

By setting p3900 to a value other than 0, the quick commissioning is completed, and this parameter is automatically reset to 0.

Procedure for "Reset parameter": Set p0010 to 30 and p0970 to 1.

Once the Control Unit has been booted up for the first time, the motor parameters suitable for the power unit have been defined, and the control parameters have been calculated accordingly, p0010 is automatically reset to 0.

p0010 = 3 is used for the subsequent commissioning of additional drive data sets (creating data sets: see p0010 = 15).

p0010 = 29, 39, 49: Only for internal Siemens use!

**p0015****Macro drive unit / Macro drv unit**

**Access level:** 1

**Calculated:** -

**Data type:** Unsigned32

**Can be changed:** C1, C2(1)

**Scaling:** -

**Dynamic index:** -

**Unit group:** -

**Unit selection:** -

**Function diagram:** -

**Min:**

**Max:**

**Factory setting:**

0

999999

57

**Description:**

Runs the corresponding macro files.

**Dependency:**

See also: p1000, r8570

## 7.3 Parameter list

**NOTICE**

After the value has been modified, no further parameter modifications can be made and the status is shown in r3996. Modifications can be made again when r3996 = 0.

When executing a specific macro, the corresponding programmed settings are made and become active.

**Note**

Macros available as standard are described in the technical documentation of the particular product.

**r0018****Control Unit firmware version / Firmware version****Access level:** 3**Calculated:** -**Data type:** Unsigned32**Can be changed:** -**Scaling:** -**Dynamic index:** -**Unit group:** -**Unit selection:** -**Function diagram:** -**Min:****Max:****Factory setting:**

0

4294967295

-

**Description:**

Displays the firmware version of the Control Unit.

**Note**

Example:

The value 1010100 should be interpreted as V01.01.01.00.

**r0020****Speed setpoint smoothed / Speed setpoint****Access level:** 2**Calculated:** -**Data type:** FloatingPoint32**Can be changed:** -**Scaling:** p2000**Dynamic index:** -**Unit group:** 3\_1**Unit selection:** p0505**Function diagram:** 5020, 6799**Min:****Max:****Factory setting:**

- [rpm]

- [rpm]

- [rpm]

**Description:**

Displays the currently smoothed speed setpoint at the input of the speed controller or U/f characteristic (after the interpolator).

**Dependency:**

See also: r0060

**Note**

Smoothing time constant = 100 ms

The signal is not suitable as a process quantity and may only be used as a display quantity.

The speed setpoint is available smoothed (r0020) and unsmoothed (r0060).

**r0021****CO: Actual speed smoothed / Actual speed****Access level:** 2**Calculated:** -**Data type:** FloatingPoint32**Can be changed:** -**Scaling:** p2000**Dynamic index:** -**Unit group:** 3\_1**Unit selection:** p0505**Function diagram:** 6799**Min:****Max:****Factory setting:**

- [rpm]

- [rpm]

- [rpm]

**Description:**

Displays the calculated and smoothed rotor speed.

Frequency components from the slip compensation (for induction motors) are not included.

**Dependency:**

See also: r0022, r0063

**Note**

Smoothing time constant = 100 ms

The signal is not suitable as a process quantity and may only be used as a display quantity.

The speed actual value is available smoothed (r0021, r0022) and unsmoothed (r0063).

<b>r0022</b>	<b>Actual speed rpm smoothed / Actual speed</b>		
	<b>Access level:</b> 3	<b>Calculated:</b> -	<b>Data type:</b> FloatingPoint32
	<b>Can be changed:</b> -	<b>Scaling:</b> p2000	<b>Dynamic index:</b> -
	<b>Unit group:</b> -	<b>Unit selection:</b> -	<b>Function diagram:</b> 6799
	<b>Min:</b> - [rpm]	<b>Max:</b> - [rpm]	<b>Factory setting:</b> - [rpm]
<b>Description:</b>	Displays the calculated and smoothed rotor speed. Frequency components from the slip compensation (for induction motors) are not included. r0022 is identical to r0021, however, it always has units of rpm and contrary to r0021 cannot be changed over.		
<b>Dependency:</b>	See also: r0021, r0063		
	<b>Note</b> Smoothing time constant = 100 ms The signal is not suitable as a process quantity and may only be used as a display quantity. The speed actual value is available smoothed (r0021, r0022) and unsmoothed (r0063).		
<b>r0024</b>	<b>Output frequency smoothed / Output frequency</b>		
	<b>Access level:</b> 3	<b>Calculated:</b> -	<b>Data type:</b> FloatingPoint32
	<b>Can be changed:</b> -	<b>Scaling:</b> p2000	<b>Dynamic index:</b> -
	<b>Unit group:</b> -	<b>Unit selection:</b> -	<b>Function diagram:</b> 6300, 6799
	<b>Min:</b> - [Hz]	<b>Max:</b> - [Hz]	<b>Factory setting:</b> - [Hz]
<b>Description:</b>	Displays the smoothed output frequency. Frequency components from the slip compensation (for induction motors) are included.		
<b>Dependency:</b>	See also: r0066		
	<b>Note</b> Smoothing time constant = 100 ms The signal is not suitable as a process quantity and may only be used as a display quantity. The output frequency is available smoothed (r0024) and unsmoothed (r0066).		
<b>r0025</b>	<b>CO: Output voltage smoothed / Output voltage</b>		
	<b>Access level:</b> 2	<b>Calculated:</b> -	<b>Data type:</b> FloatingPoint32
	<b>Can be changed:</b> -	<b>Scaling:</b> p2001	<b>Dynamic index:</b> -
	<b>Unit group:</b> -	<b>Unit selection:</b> -	<b>Function diagram:</b> 5730, 6300, 6799
	<b>Min:</b> - [Vrms]	<b>Max:</b> - [Vrms]	<b>Factory setting:</b> - [Vrms]
<b>Description:</b>	Displays the smoothed output voltage of the power unit.		
<b>Dependency:</b>	See also: r0072		
	<b>Note</b> Smoothing time constant = 100 ms The signal is not suitable as a process quantity and may only be used as a display quantity. The output voltage is available smoothed (r0025) and unsmoothed (r0072).		
<b>r0026</b>	<b>CO: DC link voltage smoothed / DC link voltage</b>		
	<b>Access level:</b> 2	<b>Calculated:</b> -	<b>Data type:</b> FloatingPoint32
	<b>Can be changed:</b> -	<b>Scaling:</b> p2001	<b>Dynamic index:</b> -
	<b>Unit group:</b> -	<b>Unit selection:</b> -	<b>Function diagram:</b> 6799
	<b>Min:</b> - [V]	<b>Max:</b> - [V]	<b>Factory setting:</b> - [V]

7.3 Parameter list

**Description:** Displays the smoothed actual value of the DC link voltage.

**Dependency:** See also: r0070

**NOTICE**  
When measuring a DC link voltage < 200 V, for the Power Module (e.g. PM240) a valid measured value is not supplied. In this case, when an external 24 V power supply is connected, a value of approx. 24 V is displayed in the display parameter.

**Note**

Smoothing time constant = 100 ms

The signal is not suitable as a process quantity and may only be used as a display quantity.

The DC link voltage is available smoothed (r0026) and unsmoothed (r0070).

r0026 sets itself to the lower value of the pulsating DC link voltage.

**r0027**

**CO: Absolute actual current smoothed / Motor current**

**Access level:** 2

**Calculated:** -

**Data type:** FloatingPoint32

**Can be changed:** -

**Scaling:** p2002

**Dynamic index:** -

**Unit group:** -

**Unit selection:** -

**Function diagram:** 5730, 6799, 8850, 8950

**Min:**

**Max:**

**Factory setting:**

- [Arms]

- [Arms]

- [Arms]

**Description:** Displays the smoothed absolute actual current value.

**Dependency:** See also: r0068

**NOTICE**  
This smoothed signal is not suitable for diagnostics or evaluation of dynamic operations. In this case, the unsmoothed value should be used.

**Note**

Smoothing time constant = 300 ms

The signal is not suitable as a process quantity and may only be used as a display quantity.

The absolute current actual value is available smoothed (r0027) and unsmoothed (r0068).

**r0031**

**Actual torque smoothed / Actual torque**

**Access level:** 2

**Calculated:** -

**Data type:** FloatingPoint32

**Can be changed:** -

**Scaling:** p2003

**Dynamic index:** -

**Unit group:** 7\_1

**Unit selection:** p0505

**Function diagram:** 5730, 6799

**Min:**

**Max:**

**Factory setting:**

- [Nm]

- [Nm]

- [Nm]

**Description:** Displays the smoothed torque actual value.

**Dependency:** See also: r0080

**Note**

Smoothing time constant = 100 ms

The signal is not suitable as a process quantity and may only be used as a display quantity.

The torque actual value is available smoothed (r0031) and unsmoothed (r0080).

**r0032**

**CO: Active power actual value smoothed / Power**

**Access level:** 2

**Calculated:** -

**Data type:** FloatingPoint32

**Can be changed:** -

**Scaling:** r2004

**Dynamic index:** -

**Unit group:** 14\_10

**Unit selection:** p0505

**Function diagram:** 5730, 6799, 8750, 8850, 8950

**Min:**

**Max:**

**Factory setting:**

- [kW]

- [kW]

- [kW]

**Description:** Displays the smoothed actual value of the active power.

**Dependency:** See also: r0082

<b>NOTICE</b>
---------------

This smoothed signal is not suitable for diagnostics or evaluation of dynamic operations. In this case, the unsmoothed value should be used.
--

**Note**

Power delivered at the motor shaft.

The active power is available smoothed (r0032 with 100 ms) and unsmoothed (r0082).

**r0034**

**CO: Motor utilization thermal / Mot\_util therm**

**Access level:** 2

**Calculated:** -

**Data type:** FloatingPoint32

**Can be changed:** -

**Scaling:** PERCENT

**Dynamic index:** -

**Unit group:** -

**Unit selection:** -

**Function diagram:** 8017

**Min:**

**Max:**

**Factory setting:**

- [%]

- [%]

- [%]

**Description:**

Display and connector output for the motor utilization from motor temperature model 1 (I2t).

For firmware version < 4.7 SP6 or p0612.12 = 0:

-  $r0034 = (\text{motor model temperature} - 40 \text{ K}) / (\text{p0605} - 40 \text{ K}) * 100 \%$

From firmware version 4.7 SP6 and p0612.12 = 1:

-  $r0034 = (\text{motor model temperature} - \text{p0613}) / (\text{p0605} - \text{p0613}) * 100 \%$

**Dependency:**

The thermal motor utilization is only determined when the motor temperature model 1 (I2t) is activated.

The following conditions are a prerequisite for additional information.

- a temperature sensor has not been parameterized (p0600, p0601).

- the current corresponds to the stall current (p0318).

- speed  $n > 1$  [rpm].

For firmware version < 4.7 SP6 or p0612.12 = 0, the following applies:

- the temperature model operates with an ambient temperature of 20 °C.

A motor utilization of 100% is displayed ( $r0034 = 100 \%$ ) when the following conditions are permanently fulfilled:

- the ambient temperature is 40 °C (model 1: p0625 = 40 °C, model 3: p0613 = 40 °C).

From firmware version 4.7 SP6 and p0612.12 = 1, the following applies:

- the ambient temperature can be adapted to the conditions using p0613.

See also: p0605, p0611, p0612, p0613, p0627, r0632

See also: F07011, A07012

<b>NOTICE</b>
---------------

After the drive is switched on, the system starts to determine the motor temperature with an assumed model value. This means that the value for the motor utilization is only valid after a stabilization time.
---

**Note**

Smoothing time constant = 100 ms

The signal is not suitable as a process quantity and may only be used as a display quantity.

For  $r0034 = -200.0 \%$ , the following applies:

The value is invalid (e.g. the motor temperature model is not activated or has been incorrectly parameterized).

**r0035**

**CO: Motor temperature / Mot temp**

**Access level:** 2

**Calculated:** -

**Data type:** FloatingPoint32

**Can be changed:** -

**Scaling:** p2006

**Dynamic index:** -

**Unit group:** 21\_1

**Unit selection:** p0505

**Function diagram:** 8016, 8017

**Min:**

**Max:**

**Factory setting:**

- [°C]

- [°C]

- [°C]

**Description:**

Display and connector output for the actual temperature in the motor.

7.3 Parameter list

**Note**

For r0035 not equal to -200.0 °C, the following applies:

- this temperature display is valid.
- a KTY/PT1000 temperature sensor is connected.
- the thermal model for the induction motor is activated (p0612 bit 1 = 1 and temperature sensor deactivated: p0600 = 0 or p0601 = 0).

For r0035 equal to -200.0 °C, the following applies:

- this temperature display is not valid (temperature sensor error).
- a PTC sensor or bimetallic NC contact is connected.
- the temperature sensor of the synchronous motor is deactivated (p0600 = 0 or p0601 = 0).

**r0036**

**CO: Power unit overload I2t / PM overload I2t**

<b>Access level:</b> 3	<b>Calculated:</b> -	<b>Data type:</b> FloatingPoint32
<b>Can be changed:</b> -	<b>Scaling:</b> PERCENT	<b>Dynamic index:</b> -
<b>Unit group:</b> -	<b>Unit selection:</b> -	<b>Function diagram:</b> 8021
<b>Min:</b> - [%]	<b>Max:</b> - [%]	<b>Factory setting:</b> - [%]

**Description:**

Displays the power unit overload determined using the I2t calculation.  
 A current reference value is defined for the I2t monitoring of the power unit. It represents the current that can be conducted by the power unit without any influence of the switching losses (e.g. the continuously permissible current of the capacitors, inductances, busbars, etc.).  
 If the I2t reference current of the power unit is not exceeded, then an overload (0 %) is not displayed.  
 In the other case, the degree of thermal overload is calculated, whereby 100% results in a trip.

**Dependency:**

See also: p0290  
 See also: F30005

**r0037[0...19]**

**CO: Power unit temperatures / PM temperatures**

CUG120X\_PN  
 (PM330)

<b>Access level:</b> 3	<b>Calculated:</b> -	<b>Data type:</b> FloatingPoint32
<b>Can be changed:</b> -	<b>Scaling:</b> p2006	<b>Dynamic index:</b> -
<b>Unit group:</b> 21_1	<b>Unit selection:</b> p0505	<b>Function diagram:</b> 8021
<b>Min:</b> - [°C]	<b>Max:</b> - [°C]	<b>Factory setting:</b> - [°C]

**Description:**

Display and connector output for the temperature in the power unit.



<b>Index:</b>	[0] = Inverter maximum value
	[1] = Depletion layer maximum value
	[2] = Rectifier maximum value
	[3] = Air intake
	[4] = Interior of power unit
	[5] = Inverter 1
	[6] = Inverter 2
	[7] = Inverter 3
	[8] = Reserved
	[9] = Reserved
	[10] = Reserved
	[11] = Rectifier 1
	[12] = Reserved
	[13] = Depletion layer 1
	[14] = Depletion layer 2
	[15] = Depletion layer 3
	[16] = Depletion layer 4
	[17] = Depletion layer 5
	[18] = Depletion layer 6
	[19] = Reserved

**NOTICE**

Only for internal Siemens troubleshooting.

**Note**

The value of -200 indicates that there is no measuring signal.

r0037[0]: Maximum value of the inverter temperatures (r0037[5...10]).

r0037[1]: Maximum value of the depletion layer temperatures (r0037[13...18]).

r0037[2]: Maximum value of the rectifier temperatures (r0037[11...12]).

The maximum value is the temperature of the hottest inverter, depletion layer, or rectifier.

In the case of a fault, the particular shutdown threshold depends on the power unit, and cannot be read out.

<b>r0039[0...2]</b>	<b>CO: Energy display / Energy display</b>	<b>Access level:</b> 2	<b>Calculated:</b> -	<b>Data type:</b> FloatingPoint32
		<b>Can be changed:</b> -	<b>Scaling:</b> -	<b>Dynamic index:</b> -
		<b>Unit group:</b> -	<b>Unit selection:</b> -	<b>Function diagram:</b> -
		<b>Min:</b>	<b>Max:</b>	<b>Factory setting:</b>
		- [kWh]	- [kWh]	- [kWh]
<b>Description:</b>	Displays the energy values at the output terminals of the power unit.			
<b>Recommendation:</b>	r0042 should be used as process energy display. R0039 supplies as Bico source floating point values in Ws.			
<b>Index:</b>	[0] = Energy balance (sum)			
	[1] = Energy drawn			
	[2] = Energy fed back			
<b>Dependency:</b>	See also: p0040			

**Note**

For index 0:

Difference between the energy drawn and energy that is fed back.

<b>p0040</b>	<b>Reset energy consumption display / Energy usage reset</b>		
	<b>Access level:</b> 3	<b>Calculated:</b> -	<b>Data type:</b> Unsigned8
	<b>Can be changed:</b> T, U	<b>Scaling:</b> -	<b>Dynamic index:</b> -
	<b>Unit group:</b> -	<b>Unit selection:</b> -	<b>Function diagram:</b> -
	<b>Min:</b> 0	<b>Max:</b> 1	<b>Factory setting:</b> 0
<b>Description:</b>	Setting to reset the display in r0039 and r0041. Procedure: Set p0040 = 0 --> 1 The displays are reset and the parameter is automatically set to zero.		
<b>Dependency:</b>	See also: r0039		
	<b>Note</b> When this display is reset (p0040), then the process energy display (r0042) is also reset.		
<b>r0041</b>	<b>Energy consumption saved / Energy cons saved</b>		
	<b>Access level:</b> 2	<b>Calculated:</b> -	<b>Data type:</b> FloatingPoint32
	<b>Can be changed:</b> -	<b>Scaling:</b> -	<b>Dynamic index:</b> -
	<b>Unit group:</b> -	<b>Unit selection:</b> -	<b>Function diagram:</b> -
	<b>Min:</b> - [kWh]	<b>Max:</b> - [kWh]	<b>Factory setting:</b> - [kWh]
<b>Description:</b>	Displays the saved energy referred to 100 operating hours.		
<b>Dependency:</b>	See also: p0040		
	<b>Note</b> This display is used for a fluid-flow machine. The flow characteristic is entered into p3320 ... p3329. For an operating time of below 100 hours, the display is interpolated up to 100 hours.		
<b>r0042[0...2]</b>	<b>CO: Process energy display / Proc energy disp</b>		
	<b>Access level:</b> 2	<b>Calculated:</b> -	<b>Data type:</b> Integer32
	<b>Can be changed:</b> -	<b>Scaling:</b> -	<b>Dynamic index:</b> -
	<b>Unit group:</b> -	<b>Unit selection:</b> -	<b>Function diagram:</b> -
	<b>Min:</b> - [Wh]	<b>Max:</b> - [Wh]	<b>Factory setting:</b> - [Wh]
<b>Description:</b>	Display and connector output for the energy values at the output terminals of the power unit.		
<b>Index:</b>	[0] = Energy balance (sum) [1] = Energy drawn [2] = Energy fed back		
<b>Dependency:</b>	See also: p0043		
	<b>Note</b> The signal can be displayed as process variable (scaling: 1 = 1 Wh). This is enabled in p0043. The display is also reset with p0040 = 1. If an enable is present in r0043 when the Control Unit powers up, then the value from r0039 is transferred into r0042. As r0039 serves as a reference signal for r0042, due to format reasons, the process energy display can only process values of r0039 up to 2147483 kWh. r0039 should also be reset using this value.		

<b>p0043</b>	<b>BI: Enable energy usage display / Enab energy usage</b>	<b>Access level:</b> 2	<b>Calculated:</b> -	<b>Data type:</b> Unsigned32 / Binary
		<b>Can be changed:</b> T, U	<b>Scaling:</b> -	<b>Dynamic index:</b> -
		<b>Unit group:</b> -	<b>Unit selection:</b> -	<b>Function diagram:</b> -
		<b>Min:</b>	<b>Max:</b>	<b>Factory setting:</b>
		-	-	0

**Description:** Sets the signal source to enable/reset the process energy display in r0042.  
 BI: p0043 = 1 signal:  
 The process energy display is enabled in r0042.

**Dependency:** See also: r0042

<b>p0045</b>	<b>Display values smoothing time constant / Disp_val T_smooth</b>	<b>Access level:</b> 3	<b>Calculated:</b> -	<b>Data type:</b> FloatingPoint32
		<b>Can be changed:</b> T, U	<b>Scaling:</b> -	<b>Dynamic index:</b> -
		<b>Unit group:</b> -	<b>Unit selection:</b> -	<b>Function diagram:</b> 6799
		<b>Min:</b>	<b>Max:</b>	<b>Factory setting:</b>
		0.00 [ms]	10000.00 [ms]	4.00 [ms]

**Description:** Sets the smoothing time constant for the following display values:  
 r0063[1], r0068[1], r0080[1], r0082[1].

<b>r0046.0...31</b>	<b>CO/BO: Missing enable signal / Missing enable sig</b>	<b>Access level:</b> 1	<b>Calculated:</b> -	<b>Data type:</b> Unsigned32
		<b>Can be changed:</b> -	<b>Scaling:</b> -	<b>Dynamic index:</b> -
		<b>Unit group:</b> -	<b>Unit selection:</b> -	<b>Function diagram:</b> 2634
		<b>Min:</b>	<b>Max:</b>	<b>Factory setting:</b>
		-	-	-

**Description:** Display and BICO output for missing enable signals that are preventing the closed-loop drive control from being commissioned.

<b>Bit field:</b>	<b>Bit</b>	<b>Signal name</b>	<b>1 signal</b>	<b>0 signal</b>	<b>FP</b>
	00	OFF1 enable missing	Yes	No	7954
	01	OFF2 enable missing	Yes	No	-
	02	OFF3 enable missing	Yes	No	-
	03	Operation enable missing	Yes	No	-
	04	DC braking enable missing	Yes	No	-
	08	Safety enable missing	Yes	No	-
	10	Ramp-function generator enable missing	Yes	No	-
	11	Ramp-function generator start missing	Yes	No	-
	12	Setpoint enable missing	Yes	No	-
	16	OFF1 enable internal missing	Yes	No	-
	17	OFF2 enable internal missing	Yes	No	-
	18	OFF3 enable internal missing	Yes	No	-
	19	Pulse enable internal missing	Yes	No	-
	20	DC braking internal enable missing	Yes	No	-
	21	Power unit enable missing	Yes	No	-
	25	Function bypass active	Yes	No	-
	26	Drive inactive or not operational	Yes	No	-
	27	De-magnetizing not completed	Yes	No	-
	30	Speed controller inhibited	Yes	No	-
	31	Jog setpoint active	Yes	No	-

**Dependency:** See also: r0002

---

**Note**

The value r0046 = 0 indicates that all enable signals for this drive are present.

Bit 00 = 1 (enable signal missing), if:

- the signal source in p0840 is a 0 signal.
- there is a "switching on inhibited".

Bit 01 = 1 (enable signal missing), if:

- the signal source in p0844 or p0845 is a 0 signal.

Bit 02 = 1 (enable signal missing), if:

- the signal source in p0848 or p0849 is a 0 signal.

Bit 03 = 1 (enable signal missing), if:

- the signal source in p0852 is a 0 signal.

Bit 04 = 1 (DC brake active) when:

- the signal source in p1230 has a 1 signal.

Bit 08 = 1 (enable signal missing), if:

- the "STO via terminals at the Power Module" function is selected.

Bit 10 = 1 (enable signal missing), if:

- the signal source in p1140 is a 0 signal.

Bit 11 = 1 (enable signal missing) if the speed setpoint is frozen, because:

- the signal source in p1141 is a 0 signal.
- the speed setpoint is entered from jogging and the two signal sources for jogging, bit 0 (p1055) and bit 1 (p1056) have a 1 signal.

Bit 12 = 1 (enable signal missing), if:

- the signal source in p1142 is a 0 signal.

Bit 16 = 1 (enable signal missing), if:

- there is an OFF1 fault response. The system is only enabled if the fault is removed and was acknowledged and the "switching on inhibited" withdrawn with OFF1 = 0.

Bit 17 = 1 (enable signal missing), if:

- commissioning mode is selected (p0010 > 0).
- there is an OFF2 fault response.
- the drive is not operational.

Bit 18 = 1 (enable signal missing), if:

- OFF3 has still not been completed or an OFF3 fault response is present.

Bit 19 = 1 (internal pulse enable missing), if:

- sequence control does not have a finished message.

Bit 20 = 1 (internal DC brake active), if:

- the drive is not in the state "Operation" or in "OFF1/OFF3".
- the internal pulse enable is missing (r0046.19 = 0).

Bit 21 = 1 (enable signal missing), if:

- the power unit does not issue an enable signal (e.g. because DC link voltage is too low).
- the hibernation mode is active.

Bit 25 = 1 (function bypass active) if:

- the bypass function is active.

Bit 26 = 1 (enable signal missing), if:

- the drive is not operational.

Bit 27 = 1 (enable signal missing), if:

- de-magnetization not completed.

Bit 30 = 1 (speed controller inhibited), if one of the following reasons is present:

- the pole position identification is active.
- motor data identification is active (only certain steps).

Bit 31 = 1 (enable signal missing), if:

- the speed setpoint from jog 1 or 2 is entered.
-

<b>r0047</b>	<b>Motor data identification and speed controller optimization / MotID and n_opt</b>		
	<b>Access level:</b> 1	<b>Calculated:</b> -	<b>Data type:</b> Integer16
	<b>Can be changed:</b> -	<b>Scaling:</b> -	<b>Dynamic index:</b> -
	<b>Unit group:</b> -	<b>Unit selection:</b> -	<b>Function diagram:</b> -
	<b>Min:</b> 0	<b>Max:</b> 300	<b>Factory setting:</b> -
<b>Description:</b>	Displays the actual status for the motor data identification (stationary measurement) and the speed controller optimization (rotating measurement).		
<b>Value:</b>	0: No measurement 115: Measurement q leakage inductance (part 2) 120: Speed controller optimization (vibration test) 140: Calculate speed controller setting 150: Measurement moment of inertia 170: Measurement magnetizing current and saturation characteristic 195: Measurement q leakage inductance (part 1) 200: Rotating measurement selected 220: identification leakage inductance 230: Identification rotor time constant 240: Identification stator inductance 250: Identification stator inductance LQLD 260: Identification circuit 270: Identification stator resistance 290: Identification valve lockout time 300: Stationary measurement selected		

<b>r0047</b>	<b>Motor data identification and speed controller optimization / MotID and n_opt</b>		
CUG120X_PN (PM330)	<b>Access level:</b> 1	<b>Calculated:</b> -	<b>Data type:</b> Integer16
	<b>Can be changed:</b> -	<b>Scaling:</b> -	<b>Dynamic index:</b> -
	<b>Unit group:</b> -	<b>Unit selection:</b> -	<b>Function diagram:</b> -
	<b>Min:</b> 0	<b>Max:</b> 300	<b>Factory setting:</b> -
<b>Description:</b>	Displays the actual status for the motor data identification (stationary measurement) and the speed controller optimization (rotating measurement).		
<b>Value:</b>	0: No measurement 115: Measurement q leakage inductance (part 2) 120: Speed controller optimization (vibration test) 140: Calculate speed controller setting 150: Measurement moment of inertia 170: Measurement magnetizing current and saturation characteristic 195: Measurement q leakage inductance (part 1) 200: Rotating measurement selected 220: identification leakage inductance 230: Identification rotor time constant 240: Identification stator inductance 250: Identification stator inductance LQLD 270: Identification stator resistance 290: Identification valve lockout time 295: Calibration output voltage measurement 300: Stationary measurement selected		

7.3 Parameter list

<b>r0050.0...1</b>	<b>CO/BO: Command Data Set CDS effective / CDS effective</b>			
	<b>Access level:</b> 3	<b>Calculated:</b> -	<b>Data type:</b> Unsigned8	
	<b>Can be changed:</b> -	<b>Scaling:</b> -	<b>Dynamic index:</b> -	
	<b>Unit group:</b> -	<b>Unit selection:</b> -	<b>Function diagram:</b> 8560	
	<b>Min:</b>	<b>Max:</b>	<b>Factory setting:</b>	
	-	-	-	
<b>Description:</b>	Displays the effective Command Data Set (CDS).			
<b>Bit field:</b>	<b>Bit</b>	<b>Signal name</b>	<b>1 signal</b>	<b>0 signal</b>
	00	CDS effective bit 0	ON	OFF
	01	CDS effective bit 1	ON	OFF
<b>Dependency:</b>	See also: p0810, p0811, r0836			
	<b>Note</b>			
	The Command Data Set selected using a binector input (e.g. p0810) is displayed using r0836.			

<b>r0051.0...1</b>	<b>CO/BO: Drive Data Set DDS effective / DDS effective</b>			
	<b>Access level:</b> 2	<b>Calculated:</b> -	<b>Data type:</b> Unsigned8	
	<b>Can be changed:</b> -	<b>Scaling:</b> -	<b>Dynamic index:</b> -	
	<b>Unit group:</b> -	<b>Unit selection:</b> -	<b>Function diagram:</b> 8565	
	<b>Min:</b>	<b>Max:</b>	<b>Factory setting:</b>	
	-	-	-	
<b>Description:</b>	Displays the effective Drive Data Set (DDS).			
<b>Bit field:</b>	<b>Bit</b>	<b>Signal name</b>	<b>1 signal</b>	<b>0 signal</b>
	00	DDS effective bit 0	ON	OFF
	01	DDS effective bit 1	ON	OFF
<b>Dependency:</b>	See also: p0820, p0821, r0837			
	<b>Note</b>			
	When selecting the motor data identification routine and the rotating measurement, the drive data set changeover is suppressed.			

<b>r0052.0...15</b>	<b>CO/BO: Status word 1 / ZSW 1</b>			
	<b>Access level:</b> 2	<b>Calculated:</b> -	<b>Data type:</b> Unsigned16	
	<b>Can be changed:</b> -	<b>Scaling:</b> -	<b>Dynamic index:</b> -	
	<b>Unit group:</b> -	<b>Unit selection:</b> -	<b>Function diagram:</b> -	
	<b>Min:</b>	<b>Max:</b>	<b>Factory setting:</b>	
	-	-	-	
<b>Description:</b>	Display and connector output for status word 1.			
<b>Bit field:</b>	<b>Bit</b>	<b>Signal name</b>	<b>1 signal</b>	<b>0 signal</b>
	00	Ready for switching on	Yes	No
	01	Ready	Yes	No
	02	Operation enabled	Yes	No
	03	Fault present	Yes	No
	04	Coast down active (OFF2)	No	Yes
	05	Quick Stop active (OFF3)	No	Yes
	06	Switching on inhibited active	Yes	No
	07	Alarm present	Yes	No
	08	Deviation setpoint/actual speed	No	Yes
	09	Control request	Yes	No
	10	Maximum speed reached	Yes	No

11	I, M, P limit reached	No	Yes	-
13	Alarm motor overtemperature	No	Yes	-
14	Motor rotates forwards	Yes	No	-
15	Alarm drive converter overload	No	Yes	-

**NOTICE**

p2080 is used to define the signal sources of the PROFIdrive status word interconnection.

**Note**

For bit 03:

This signal is inverted if it is interconnected to a digital output.

For r0052:

The status bits have the following sources:

Bit 00: r0899 Bit 0

Bit 01: r0899 Bit 1

Bit 02: r0899 Bit 2

Bit 03: r2139 Bit 3 (or r1214.10 for p1210 > 0)

Bit 04: r0899 Bit 4

Bit 05: r0899 Bit 5

Bit 06: r0899 Bit 6

Bit 07: r2139 Bit 7

Bit 08: r2197 Bit 7

Bit 09: r0899 Bit 7

Bit 10: r2197 Bit 6

Bit 11: r0056 Bit 13 (negated)

Bit 13: r2135 Bit 14 (negated)

Bit 14: r2197 Bit 3

Bit 15: r2135 Bit 15 (negated)

**r0053.0...11****CO/BO: Status word 2 / ZSW 2**

**Access level:** 2

**Can be changed:** -

**Unit group:** -

**Min:**

-

**Calculated:** -

**Scaling:** -

**Unit selection:** -

**Max:**

-

**Data type:** Unsigned16

**Dynamic index:** -

**Function diagram:** -

**Factory setting:**

-

**Description:**

Display and BICO output for status word 2.

**Bit field:**

Bit	Signal name	1 signal	0 signal	FP
00	DC braking active	Yes	No	-
01	n_act  > p1226 (n_standstill)	Yes	No	-
02	n_act  > p1080 (n_min)	Yes	No	-
03	I_act >= p2170	Yes	No	-
04	n_act  > p2155	Yes	No	-
05	n_act  <= p2155	Yes	No	-
06	n_act  >= r1119 (n_set)	Yes	No	-
07	Vdc <= p2172	Yes	No	-
08	Vdc > p2172	Yes	No	-
09	Ramp-up/ramp-down completed	Yes	No	-
10	Technology controller output at the lower limit	Yes	No	-
11	Technology controller output at the upper limit	Yes	No	-

**NOTICE**

p2081 is used to define the signal sources of the PROFIdrive status word interconnection.

7.3 Parameter list

**Note**

The following status bits are displayed in r0053:

- Bit 01: r2197 Bit 5 (negated)
- Bit 02: r2197 Bit 0 (negated)
- Bit 03: r2197 Bit 8
- Bit 04: r2197 Bit 2
- Bit 05: r2197 Bit 1
- Bit 06: r2197 Bit 4
- Bit 07: r2197 Bit 9
- Bit 08: r2197 Bit 10
- Bit 09: r1199 Bit 2 (negated)
- Bit 10: r2349 Bit 10
- Bit 11: r2349 Bit 11

**r0053.0...11**

CUG120X\_PN (DC braking)

**CO/BO: Status word 2 / ZSW 2**

**Access level:** 2

**Can be changed:** -

**Unit group:** -

**Min:**

-

**Calculated:** -

**Scaling:** -

**Unit selection:** -

**Max:**

-

**Data type:** Unsigned16

**Dynamic index:** -

**Function diagram:** -

**Factory setting:**

-

**Description:**

Display and BICO output for status word 2.

**Bit field:**

Bit	Signal name	1 signal	0 signal	FP
00	DC braking active	Yes	No	-
01	n_act  > p1226 (n_standstill)	Yes	No	-
02	n_act  > p1080 (n_min)	Yes	No	-
03	I_act >= p2170	Yes	No	-
04	n_act  > p2155	Yes	No	-
05	n_act  <= p2155	Yes	No	-
06	n_act  >= r1119 (n_set)	Yes	No	-
07	Vdc <= p2172	Yes	No	-
08	Vdc > p2172	Yes	No	-
09	Ramp-up/ramp-down completed	Yes	No	-
10	Technology controller output at the lower limit	Yes	No	-
11	Technology controller output at the upper limit	Yes	No	-

**NOTICE**

p2081 is used to define the signal sources of the PROFIdrive status word interconnection.

**Note**

The following status bits are displayed in r0053:

- Bit 00: r1239 Bit 8
- Bit 01: r2197 Bit 5 (negated)
- Bit 02: r2197 Bit 0 (negated)
- Bit 03: r2197 Bit 8
- Bit 04: r2197 Bit 2
- Bit 05: r2197 Bit 1
- Bit 06: r2197 Bit 4
- Bit 07: r2197 Bit 9
- Bit 08: r2197 Bit 10
- Bit 09: r1199 Bit 2 (negated)
- Bit 10: r2349 Bit 10
- Bit 11: r2349 Bit 11



<b>r0054.0...15</b>	<b>CO/BO: Control word 1 / STW 1</b>				
	<b>Access level:</b> 2	<b>Calculated:</b> -	<b>Data type:</b> Unsigned16		
	<b>Can be changed:</b> -	<b>Scaling:</b> -	<b>Dynamic index:</b> -		
	<b>Unit group:</b> -	<b>Unit selection:</b> -	<b>Function diagram:</b> -		
	<b>Min:</b> -	<b>Max:</b> -	<b>Factory setting:</b> -		
<b>Description:</b>	Displays control word 1.				
<b>Bit field:</b>	<b>Bit</b>	<b>Signal name</b>	<b>1 signal</b>	<b>0 signal</b>	<b>FP</b>
	00	ON/OFF1	Yes	No	-
	01	OC / OFF2	No	Yes	-
	02	OC / OFF3	No	Yes	-
	03	Enable operation	Yes	No	-
	04	Enable ramp-function generator	Yes	No	-
	05	Continue ramp-function generator	Yes	No	-
	06	Enable speed setpoint	Yes	No	-
	07	Acknowledge fault	Yes	No	-
	08	Jog bit 0	Yes	No	3030
	09	Jog bit 1	Yes	No	3030
	10	Master control by PLC	Yes	No	-
	11	Direction reversal (setpoint)	Yes	No	-
	13	Motorized potentiometer raise	Yes	No	-
	14	Motorized potentiometer lower	Yes	No	-
	15	CDS bit 0	Yes	No	-

**Note**

The following control bits are displayed in r0054:

Bit 00: r0898 Bit 0  
 Bit 01: r0898 Bit 1  
 Bit 02: r0898 Bit 2  
 Bit 03: r0898 Bit 3  
 Bit 04: r0898 Bit 4  
 Bit 05: r0898 Bit 5  
 Bit 06: r0898 Bit 6  
 Bit 07: r2138 Bit 7  
 Bit 08: r0898 Bit 8  
 Bit 09: r0898 Bit 9  
 Bit 10: r0898 Bit 10  
 Bit 11: r1198 Bit 11  
 Bit 13: r1198 Bit 13  
 Bit 14: r1198 Bit 14  
 Bit 15: r0836 Bit 0

<b>r0055.0...15</b>	<b>CO/BO: Supplementary control word / Suppl STW</b>				
	<b>Access level:</b> 3	<b>Calculated:</b> -	<b>Data type:</b> Unsigned16		
	<b>Can be changed:</b> -	<b>Scaling:</b> -	<b>Dynamic index:</b> -		
	<b>Unit group:</b> -	<b>Unit selection:</b> -	<b>Function diagram:</b> 2513		
	<b>Min:</b> -	<b>Max:</b> -	<b>Factory setting:</b> -		
<b>Description:</b>	Display and BICO output for supplementary control word.				
<b>Bit field:</b>	<b>Bit</b>	<b>Signal name</b>	<b>1 signal</b>	<b>0 signal</b>	<b>FP</b>
	00	Fixed setpoint bit 0	Yes	No	-
	01	Fixed setpoint bit 1	Yes	No	-

Parameters

7.3 Parameter list

02	Fixed setpoint bit 2	Yes	No	-
03	Fixed setpoint bit 3	Yes	No	-
04	DDS selection bit 0	Yes	No	-
05	DDS selection bit 1	Yes	No	-
08	Technology controller enable	Yes	No	-
09	DC braking enable	Yes	No	-
11	Reserved	-	-	-
12	Reserved	-	-	-
13	External fault 1 (F07860)	No	Yes	-
15	CDS bit 1	Yes	No	-

**Note**

CDS: Command Data Set

DDS: Drive Data Set

The following control bits are displayed in r0055:

Bit 00: r1198.0

Bit 01: r1198.1

Bit 02: r1198.2

Bit 03: r1198.3

Bit 04: r0837.0

Bit 05: r0837.1

Bit 08: r2349.0 (negated)

Bit 13: r2138.13 (negated)

Bit 15: r0836.1

**r0055.0...15**

CUG120X\_PN (DC braking)

**CO/BO: Supplementary control word / Suppl STW**

**Access level:** 3

**Calculated:** -

**Data type:** Unsigned16

**Can be changed:** -

**Scaling:** -

**Dynamic index:** -

**Unit group:** -

**Unit selection:** -

**Function diagram:** 2513

**Min:**

**Max:**

**Factory setting:**

-

-

-

**Description:**

Display and BICO output for supplementary control word.

**Bit field:**

Bit	Signal name	1 signal	0 signal	FP
00	Fixed setpoint bit 0	Yes	No	-
01	Fixed setpoint bit 1	Yes	No	-
02	Fixed setpoint bit 2	Yes	No	-
03	Fixed setpoint bit 3	Yes	No	-
04	DDS selection bit 0	Yes	No	-
05	DDS selection bit 1	Yes	No	-
08	Technology controller enable	Yes	No	-
09	DC braking enable	Yes	No	-
11	Reserved	-	-	-
12	Reserved	-	-	-
13	External fault 1 (F07860)	No	Yes	-
15	CDS bit 1	Yes	No	-

**Note**

CDS: Command Data Set

DDS: Drive Data Set

The following control bits are displayed in r0055:

Bit 00: r1198.0

Bit 01: r1198.1

Bit 02: r1198.2

Bit 03: r1198.3

Bit 04: r0837.0

Bit 05: r0837.1

Bit 08: r2349.0 (negated)

Bit 09: r1239.11

Bit 13: r2138.13 (negated)

Bit 15: r0836.1

**r0056.0...15****CO/BO: Status word, closed-loop control / ZSW cl-loop ctrl****Access level:** 3**Calculated:** -**Data type:** Unsigned16**Can be changed:** -**Scaling:** -**Dynamic index:** -**Unit group:** -**Unit selection:** -**Function diagram:** 2526**Min:****Max:****Factory setting:**

-

-

-

**Description:**

Display and BICO output for the status word of the closed-loop control.

**Bit field:**

Bit	Signal name	1 signal	0 signal	FP
00	Initialization completed	Yes	No	-
01	De-magnetizing completed	Yes	No	-
02	Pulse enable available	Yes	No	-
04	Magnetizing completed	Yes	No	-
05	Voltage boost when starting	Active	Inactive	6301
06	Acceleration voltage	Active	Inactive	6301
07	Frequency negative	Yes	No	-
08	Field weakening active	Yes	No	-
09	Voltage limit active	Yes	No	6714
10	Slip limit active	Yes	No	6310
11	Frequency limit active	Yes	No	-
12	Current limiting controller voltage output active	Yes	No	-
13	Current/torque limiting	Active	Inactive	6060
14	Vdc_max controller active	Yes	No	6220, 6320
15	Vdc_min controller active	Yes	No	6220, 6320

**r0060****CO: Speed setpoint before the setpoint filter / n\_set before filt.****Access level:** 3**Calculated:** -**Data type:** FloatingPoint32**Can be changed:** -**Scaling:** p2000**Dynamic index:** -**Unit group:** 3\_1**Unit selection:** p0505**Function diagram:** 2701, 6030,  
6799, 6822**Min:****Max:****Factory setting:**

- [rpm]

- [rpm]

- [rpm]

**Description:**

Displays the actual speed setpoint at the input of the speed controller or U/f characteristic (after the interpolator).

**Dependency:**

See also: r0020

**Note**

The speed setpoint is available smoothed (r0020) and unsmoothed (r0060).

<b>r0062</b>	<b>CO: Speed setpoint after the filter / n_set after filter</b>		
	<b>Access level:</b> 3	<b>Calculated:</b> -	<b>Data type:</b> FloatingPoint32
	<b>Can be changed:</b> -	<b>Scaling:</b> p2000	<b>Dynamic index:</b> -
	<b>Unit group:</b> 3_1	<b>Unit selection:</b> p0505	<b>Function diagram:</b> 6020, 6030, 6031, 6822
	<b>Min:</b> - [rpm]	<b>Max:</b> - [rpm]	<b>Factory setting:</b> - [rpm]
<b>Description:</b>	Display and connector output for the speed setpoint after the setpoint filters.		

<b>r0063[0...2]</b>	<b>CO: Actual speed / Actual speed</b>		
	<b>Access level:</b> 3	<b>Calculated:</b> -	<b>Data type:</b> FloatingPoint32
	<b>Can be changed:</b> -	<b>Scaling:</b> p2000	<b>Dynamic index:</b> -
	<b>Unit group:</b> 3_1	<b>Unit selection:</b> p0505	<b>Function diagram:</b> 6020, 6730, 6799, 6841
	<b>Min:</b> - [rpm]	<b>Max:</b> - [rpm]	<b>Factory setting:</b> - [rpm]
<b>Description:</b>	Display and connector output for the speed actual value. Frequency components from the slip compensation (for induction motors) are not included.		
<b>Index:</b>	[0] = Unsmoothed [1] = Smoothed with p0045 [2] = Calculated from f_set - f_slip (unsmoothed)		
<b>Dependency:</b>	See also: r0021, r0022		

**Note**

The speed actual value r0063[0] – smoothed with p0045 – is additionally displayed in r0063[1]. r0063[1] can be used as process variable for the appropriate smoothing time constant p0045.

The speed (r0063[2]) calculated from the output frequency and slip can only be compared with the speed actual value (r0063[0]) in the steady-state.

For U/f control, the mechanical speed calculated from the output frequency and the slip is shown in r0063[2] even if slip compensation is deactivated.

<b>r0064</b>	<b>CO: Speed controller system deviation / n_ctrl sys dev</b>		
	<b>Access level:</b> 3	<b>Calculated:</b> -	<b>Data type:</b> FloatingPoint32
	<b>Can be changed:</b> -	<b>Scaling:</b> p2000	<b>Dynamic index:</b> -
	<b>Unit group:</b> 3_1	<b>Unit selection:</b> p0505	<b>Function diagram:</b> 6040, 6824
	<b>Min:</b> - [rpm]	<b>Max:</b> - [rpm]	<b>Factory setting:</b> - [rpm]
<b>Description:</b>	Displays the actual system deviation of the speed controller.		

<b>r0065</b>	<b>Slip frequency / f_Slip</b>		
	<b>Access level:</b> 3	<b>Calculated:</b> -	<b>Data type:</b> FloatingPoint32
	<b>Can be changed:</b> -	<b>Scaling:</b> p2000	<b>Dynamic index:</b> -
	<b>Unit group:</b> 2_1	<b>Unit selection:</b> p0505	<b>Function diagram:</b> 6310, 6700, 6727, 6730, 6732
	<b>Min:</b> - [Hz]	<b>Max:</b> - [Hz]	<b>Factory setting:</b> - [Hz]
<b>Description:</b>	Displays the slip frequency for induction motors (ASM).		

<b>r0066</b>	<b>CO: Output frequency / f_outp</b>		
	<b>Access level:</b> 3	<b>Calculated:</b> -	<b>Data type:</b> FloatingPoint32
	<b>Can be changed:</b> -	<b>Scaling:</b> p2000	<b>Dynamic index:</b> -
	<b>Unit group:</b> 2_1	<b>Unit selection:</b> p0505	<b>Function diagram:</b> 6730, 6731, 6792, 6799, 6841, 6842, 6843
	<b>Min:</b> - [Hz]	<b>Max:</b> - [Hz]	<b>Factory setting:</b> - [Hz]
<b>Description:</b>	Display and connector output for the unsmoothed output frequency of the power unit. Frequency components from the slip compensation (induction motor) are included.		
<b>Dependency:</b>	See also: r0024		
	<b>Note</b> The output frequency is available smoothed (r0024) and unsmoothed (r0066).		
<b>r0067</b>	<b>CO: Output current maximum / Current max</b>		
	<b>Access level:</b> 3	<b>Calculated:</b> -	<b>Data type:</b> FloatingPoint32
	<b>Can be changed:</b> -	<b>Scaling:</b> p2002	<b>Dynamic index:</b> -
	<b>Unit group:</b> 6_2	<b>Unit selection:</b> p0505	<b>Function diagram:</b> 6300, 6640, 6724, 6828, 6850
	<b>Min:</b> - [Arms]	<b>Max:</b> - [Arms]	<b>Factory setting:</b> - [Arms]
<b>Description:</b>	Display and connector output for the maximum output current of the power unit.		
<b>Dependency:</b>	The maximum output current is determined by the parameterized current limit and the motor and converter thermal protection. See also: p0290, p0640		
<b>r0068[0...1]</b>	<b>CO: Absolute current actual value / I_act abs val</b>		
	<b>Access level:</b> 3	<b>Calculated:</b> -	<b>Data type:</b> FloatingPoint32
	<b>Can be changed:</b> -	<b>Scaling:</b> p2002	<b>Dynamic index:</b> -
	<b>Unit group:</b> 6_2	<b>Unit selection:</b> p0505	<b>Function diagram:</b> 6300, 6714, 6799, 7017, 8017, 8021, 8022
	<b>Min:</b> - [Arms]	<b>Max:</b> - [Arms]	<b>Factory setting:</b> - [Arms]
<b>Description:</b>	Displays actual absolute current.		
<b>Index:</b>	[0] = Unsmoothed [1] = Smoothed with p0045		
<b>Dependency:</b>	See also: r0027		
	<b>NOTICE</b> The value is updated with the current controller sampling time.		
	<b>Note</b> Absolute current value = $\sqrt{I_q^2 + I_d^2}$ The absolute value of the current actual value is available smoothed (r0027 with 300 ms, r0068[1] with p0045) and unsmoothed (r0068[0]).		

<b>r0070</b>	<b>CO: Actual DC link voltage / Vdc act val</b>		
	<b>Access level:</b> 3	<b>Calculated:</b> -	<b>Data type:</b> FloatingPoint32
	<b>Can be changed:</b> -	<b>Scaling:</b> p2001	<b>Dynamic index:</b> -
	<b>Unit group:</b> 5_2	<b>Unit selection:</b> p0505	<b>Function diagram:</b> 6723, 6724, 6730, 6731, 6799
	<b>Min:</b> - [V]	<b>Max:</b> - [V]	<b>Factory setting:</b> - [V]
<b>Description:</b>	Display and connector output for the measured actual value of the DC link voltage.		
<b>Dependency:</b>	See also: r0026		

**NOTICE**

When measuring a DC link voltage < 200 V, for the Power Module (e.g. PM240) a valid measured value is not supplied. In this case, when an external 24 V power supply is connected, a value of approx. 24 V is displayed in the display parameter.

**Note**

The DC link voltage is available smoothed (r0026) and unsmoothed (r0070).

<b>r0071</b>	<b>Maximum output voltage / Voltage max</b>		
	<b>Access level:</b> 3	<b>Calculated:</b> -	<b>Data type:</b> FloatingPoint32
	<b>Can be changed:</b> -	<b>Scaling:</b> p2001	<b>Dynamic index:</b> -
	<b>Unit group:</b> 5_1	<b>Unit selection:</b> p0505	<b>Function diagram:</b> 6301, 6640, 6700, 6722, 6723, 6724, 6725, 6727
	<b>Min:</b> - [Vrms]	<b>Max:</b> - [Vrms]	<b>Factory setting:</b> - [Vrms]
<b>Description:</b>	Displays the maximum output voltage.		
<b>Dependency:</b>	The maximum output voltage depends on the actual DC link voltage (r0070) and the maximum modulation depth (p1803).		

**Note**

As the (driven) motor load increases, the maximum output voltage drops as a result of the reduction in DC link voltage.

<b>r0072</b>	<b>CO: Output voltage / U_output</b>		
	<b>Access level:</b> 3	<b>Calculated:</b> -	<b>Data type:</b> FloatingPoint32
	<b>Can be changed:</b> -	<b>Scaling:</b> p2001	<b>Dynamic index:</b> -
	<b>Unit group:</b> 5_1	<b>Unit selection:</b> p0505	<b>Function diagram:</b> 5700, 6730, 6731, 6799
	<b>Min:</b> - [Vrms]	<b>Max:</b> - [Vrms]	<b>Factory setting:</b> - [Vrms]
<b>Description:</b>	Display and connector output for the actual output voltage of the power unit.		
<b>Dependency:</b>	See also: r0025		

**Note**

The output voltage is available smoothed (r0025) and unsmoothed (r0072).

<b>r0075</b>	<b>CO: Current setpoint field-generating / Id_set</b>		
	<b>Access level:</b> 3	<b>Calculated:</b> -	<b>Data type:</b> FloatingPoint32
	<b>Can be changed:</b> -	<b>Scaling:</b> p2002	<b>Dynamic index:</b> -
	<b>Unit group:</b> 6_2	<b>Unit selection:</b> p0505	<b>Function diagram:</b> 6700, 6714, 6725
	<b>Min:</b> - [Arms]	<b>Max:</b> - [Arms]	<b>Factory setting:</b> - [Arms]

**Description:** Display and connector output for the field-generating current setpoint (Id\_set).

**Note**

This value is irrelevant for the U/f control mode.

**r0076****CO: Current actual value field-generating / Id\_act****Access level:** 3**Calculated:** -**Data type:** FloatingPoint32**Can be changed:** -**Scaling:** p2002**Dynamic index:** -**Unit group:** 6\_2**Unit selection:** p0505**Function diagram:** 5700, 5714, 5730, 6700, 6714, 6799**Min:****Max:****Factory setting:**

- [Arms]

- [Arms]

- [Arms]

**Description:**

Display and connector output for the field-generating current actual value (Id\_act).

**Note**

This value is irrelevant for the U/f control mode.

The field-generating current actual value is available smoothed (r0029) and unsmoothed (r0076).

**r0077****CO: Current setpoint torque-generating / Iq\_set****Access level:** 3**Calculated:** -**Data type:** FloatingPoint32**Can be changed:** -**Scaling:** p2002**Dynamic index:** -**Unit group:** 6\_2**Unit selection:** p0505**Function diagram:** 6700, 6710**Min:****Max:****Factory setting:**

- [Arms]

- [Arms]

- [Arms]

**Description:**

Display and connector output for the torque-generating current setpoint.

**Note**

This value is irrelevant for the U/f control mode.

**r0078****CO: Current actual value torque-generating / Iq\_act****Access level:** 3**Calculated:** -**Data type:** FloatingPoint32**Can be changed:** -**Scaling:** p2002**Dynamic index:** -**Unit group:** 6\_2**Unit selection:** p0505**Function diagram:** 6310, 6700, 6714, 6799**Min:****Max:****Factory setting:**

- [Arms]

- [Arms]

- [Arms]

**Description:**

Display and connector output for the torque-generating current actual value (Iq\_act).

**Note**

This value is irrelevant for the U/f control mode.

The torque-generating current actual value is available smoothed (r0030 with 300 ms) and unsmoothed (r0078).

**r0079****CO: Torque setpoint / M\_set****Access level:** 3**Calculated:** -**Data type:** FloatingPoint32**Can be changed:** -**Scaling:** p2003**Dynamic index:** -**Unit group:** 7\_1**Unit selection:** p0505**Function diagram:** 6020, 6060, 6710**Min:****Max:****Factory setting:**

- [Nm]

- [Nm]

- [Nm]

**Description:**

Display and connector output for the torque setpoint at the output of the speed controller.

---

<b>r0080[0...1]</b>	<b>CO: Torque actual value / Actual torque</b>		
	<b>Access level:</b> 3	<b>Calculated:</b> -	<b>Data type:</b> FloatingPoint32
	<b>Can be changed:</b> -	<b>Scaling:</b> p2003	<b>Dynamic index:</b> -
	<b>Unit group:</b> 7_1	<b>Unit selection:</b> p0505	<b>Function diagram:</b> 6714, 6799
	<b>Min:</b> - [Nm]	<b>Max:</b> - [Nm]	<b>Factory setting:</b> - [Nm]
<b>Description:</b>	Display and connector output for actual torque value.		
<b>Index:</b>	[0] = Unsmoothed [1] = Smoothed with p0045		
<b>Dependency:</b>	See also: r0031, p0045		

**Note**

The value is available smoothed (r0031 with 100 ms, r0080[1] with p0045) and unsmoothed (r0080[0]).

---

<b>r0082[0...2]</b>	<b>CO: Active power actual value / P_act</b>		
	<b>Access level:</b> 3	<b>Calculated:</b> -	<b>Data type:</b> FloatingPoint32
	<b>Can be changed:</b> -	<b>Scaling:</b> r2004	<b>Dynamic index:</b> -
	<b>Unit group:</b> 14_5	<b>Unit selection:</b> p0505	<b>Function diagram:</b> 6714, 6799
	<b>Min:</b> - [kW]	<b>Max:</b> - [kW]	<b>Factory setting:</b> - [kW]
<b>Description:</b>	Displays the instantaneous active power.		
<b>Index:</b>	[0] = Unsmoothed [1] = Smoothed with p0045 [2] = Electric power		
<b>Dependency:</b>	See also: r0032		

**Note**

The mechanical active power is available smoothed (r0032 with 100 ms, r0082[1] with p0045) and unsmoothed (r0082[0]).

---

<b>r0087</b>	<b>CO: Actual power factor / Cos phi act</b>		
	<b>Access level:</b> 3	<b>Calculated:</b> -	<b>Data type:</b> FloatingPoint32
	<b>Can be changed:</b> -	<b>Scaling:</b> -	<b>Dynamic index:</b> -
	<b>Unit group:</b> -	<b>Unit selection:</b> -	<b>Function diagram:</b> -
	<b>Min:</b> -	<b>Max:</b> -	<b>Factory setting:</b> -
<b>Description:</b>	Displays the actual active power factor. This value refers to the electrical power of the basic fundamental signals at the output terminals of the converter.		

---

<b>p0096</b>	<b>Application class / Appl_class</b>		
	<b>Access level:</b> 1	<b>Calculated:</b> -	<b>Data type:</b> Integer16
	<b>Can be changed:</b> C2(1)	<b>Scaling:</b> -	<b>Dynamic index:</b> -
	<b>Unit group:</b> -	<b>Unit selection:</b> -	<b>Function diagram:</b> 6019
	<b>Min:</b> 0	<b>Max:</b> 2	<b>Factory setting:</b> 0
<b>Description:</b>	Setting the commissioning and control view for various application classes.		
<b>Value:</b>	0: Expert 1: Standard Drive Control (SDC) 2: Dynamic Drive Control (DDC)		



**Dependency:** The parameter is preset when commissioning the system for the first time and for the factory setting, depending on the power unit that is connected.  
 Depending on the setting, the ability to see control parameters is restricted depending on the particular application.  
 The following applies for p0096 > 0:  
 The motor data identification routine is preset (p1900 = 2).  
 The following applies for p0096 = 1:  
 The motor type (p0300) synchronous or reluctance motor is not possible.

**Note**

When changing p0096 to 1 or 2, when completing commissioning, fast parameterization should be executed (p3900 > 0).

Depending on the setting, after quick commissioning and/or automatic parameterization, the procedure for motor data identification as well as the setting of the operating mode and parameterization of the closed-loop control must be appropriately adapted.

**p0096**

CUG120X\_PN  
(PM330)

**Application class / Appl\_class****Access level:** 1**Calculated:** -**Data type:** Integer16**Can be changed:** C2(1)**Scaling:** -**Dynamic index:** -**Unit group:** -**Unit selection:** -**Function diagram:** 6019**Min:****Max:****Factory setting:**

0

2

0

**Description:**

Setting the commissioning and control view for various application classes.

**Value:**

0: Expert  
 2: Dynamic Drive Control (DDC)

**Dependency:**

The parameter is preset when commissioning the system for the first time and for the factory setting, depending on the power unit that is connected.  
 Depending on the setting, the ability to see control parameters is restricted depending on the particular application.  
 The following applies for p0096 > 0:  
 The motor data identification routine is preset (p1900 = 2).

**Note**

When changing p0096 to 1 or 2, when completing commissioning, fast parameterization should be executed (p3900 > 0).

Depending on the setting, after quick commissioning and/or automatic parameterization, the procedure for motor data identification as well as the setting of the operating mode and parameterization of the closed-loop control must be appropriately adapted.

**p0100****IEC/NEMA Standards / IEC/NEMA Standards****Access level:** 1**Calculated:** -**Data type:** Integer16**Can be changed:** C2(1, 2)**Scaling:** -**Dynamic index:** -**Unit group:** -**Unit selection:** -**Function diagram:** -**Min:****Max:****Factory setting:**

0

2

0

**Description:**

Defines whether the motor and drive converter power settings (e.g. rated motor power, p0307) are expressed in [kW] or [hp].

Depending on the selection, the rated motor frequency (p0310) is either set to 50 Hz or 60 Hz.

For p0100 = 0, 2, the following applies: The power factor (p0308) should be parameterized.

For p0100 = 1, the following applies: The efficiency (p0309) should be parameterized.

**Value:**

0: IEC (50 Hz line, SI units)  
 1: NEMA (60 Hz line, US units)  
 2: NEMA (60 Hz line, SI units)

7.3 Parameter list

**Dependency:** If p0100 is changed, all of the rated motor parameters are reset. Only then are possible unit changeovers made. The units of all motor parameters are changed that are involved in the selection of IEC or NEMA (e.g. r0206, p0307, r0333, r0334, p0341, p0344, r1969). See also: r0206, p0210, p0300, p0304, p0305, p0307, p0308, p0309, p0310, p0311, p0320, p0322, p0323, p0335, p1800

**Note**

The parameter value is not reset when the factory setting is restored (p0010 = 30, p0970).

**p0124[0...n]**

**CU detection via LED / CU detection LED**

<b>Access level:</b> 3	<b>Calculated:</b> -	<b>Data type:</b> Unsigned8
<b>Can be changed:</b> T, U	<b>Scaling:</b> -	<b>Dynamic index:</b> PDS, p0120
<b>Unit group:</b> -	<b>Unit selection:</b> -	<b>Function diagram:</b> -
<b>Min:</b> 0	<b>Max:</b> 1	<b>Factory setting:</b> 0

**Description:** Identification of the Control Unit using an LED.

**Note**

While p0124 = 1, the READY LED flashes green/orange or red/orange with 2 Hz at the appropriate Control Unit.

**p0133[0...n]**

**Motor configuration / Motor config**

<b>Access level:</b> 2	<b>Calculated:</b> -	<b>Data type:</b> Unsigned16
<b>Can be changed:</b> C2(1, 3)	<b>Scaling:</b> -	<b>Dynamic index:</b> MDS, p0130
<b>Unit group:</b> -	<b>Unit selection:</b> -	<b>Function diagram:</b> -
<b>Min:</b> -	<b>Max:</b> -	<b>Factory setting:</b> 0000 bin

**Description:** Configuration of the motor when commissioning the motor.

<b>Bit field:</b>	<b>Bit</b>	<b>Signal name</b>	<b>1 signal</b>	<b>0 signal</b>	<b>FP</b>
	00	Motor connection type	Delta	Star	-
	01	Motor 87 Hz operation	Yes	No	-

**Dependency:** For standard induction motors (p0301 > 10000), bit 0 is automatically pre-assigned the connection type of the selected data set. For p0100 > 0 (60 Hz rated motor frequency), it is not possible to select bit 1. See also: p0304, p0305, p1082

**Note**

For bit 00:  
When changing the bits, the rated motor voltage p0304 and the rated motor current p0305 are automatically converted to the selected connection type (star/delta).  
For bit 01:  
87 Hz operation is only possible in the delta connection type. When selected, the maximum speed p1082 is automatically pre-assigned for a maximum output frequency of 87 Hz.

**p0170**

**Number of Command Data Sets (CDS) / CDS count**

<b>Access level:</b> 2	<b>Calculated:</b> -	<b>Data type:</b> Unsigned8
<b>Can be changed:</b> C2(15)	<b>Scaling:</b> -	<b>Dynamic index:</b> -
<b>Unit group:</b> -	<b>Unit selection:</b> -	<b>Function diagram:</b> 8560
<b>Min:</b> 2	<b>Max:</b> 4	<b>Factory setting:</b> 2

**Description:** Sets the number of Command Data Sets (CDS).

**Dependency:** See also: p0010, r3996

**NOTICE**

When the data sets are created, short-term communication interruptions may occur.

**Note**

It is possible to toggle between command parameters (BICO parameters) using this data set changeover.

**p0180****Number of Drive Data Sets (DDS) / DDS count****Access level:** 3**Calculated:** -**Data type:** Unsigned8**Can be changed:** C2(15)**Scaling:** -**Dynamic index:** -**Unit group:** -**Unit selection:** -**Function diagram:** 8565**Min:****Max:****Factory setting:**

1

4

1

**Description:**

Sets the number of Drive Data Sets (DDS).

**Dependency:**

See also: p0010, r3996

**NOTICE**

When the data sets are created, short-term communication interruptions may occur.

**r0200[0...n]****Power unit code number actual / PU code no. act****Access level:** 3**Calculated:** -**Data type:** Unsigned16**Can be changed:** -**Scaling:** -**Dynamic index:** PDS, p0120**Unit group:** -**Unit selection:** -**Function diagram:** -**Min:****Max:****Factory setting:**

-

-

-

**Description:**

Displays the unique code number of the power unit.

**Note**

r0200 = 0: No power unit data found

**p0201[0...n]****Power unit code number / PU code no****Access level:** 3**Calculated:** -**Data type:** Unsigned16**Can be changed:** C2(2)**Scaling:** -**Dynamic index:** PDS, p0120**Unit group:** -**Unit selection:** -**Function diagram:** -**Min:****Max:****Factory setting:**

0

65535

0

**Description:**

Sets the actual code number from r0200 to acknowledge the power unit being used.

When commissioned for the first time, the code number is automatically transferred from r0200 into p0201.

**Note**

The parameter is used to identify when the drive is being commissioned for the first time.

The power unit commissioning can only be exited (p0201 = r0200), if the actual and acknowledged code numbers are identical (p0010 = 2).

When the code number is changed, the connection voltage (p0210) is checked and, if necessary, adjusted.

**r0203[0...n]****Actual power unit type / PU actual type****Access level:** 3**Calculated:** -**Data type:** Integer16**Can be changed:** -**Scaling:** -**Dynamic index:** PDS, p0120**Unit group:** -**Unit selection:** -**Function diagram:** -**Min:****Max:****Factory setting:**

2

400

-

**Description:**

Displays the type of power unit found.

**Value:**

2: MICROMASTER 440

3: MICROMASTER 411

4: MICROMASTER 410

7.3 Parameter list

5:	MICROMASTER 436
6:	MICROMASTER 440 PX
7:	MICROMASTER 430
100:	SINAMICS S
101:	SINAMICS S (value)
102:	SINAMICS S (combi)
103:	SINAMICS S120M (distributed)
112:	PM220 (SINAMICS G120)
113:	PM230 (SINAMICS G120)
114:	PM240 (SINAMICS G120 / S120)
115:	PM250 (SINAMICS G120 / S120)
116:	PM260 (SINAMICS G120)
118:	SINAMICS G120 Px
120:	PM340 (SINAMICS S120 / G120)
126:	SINAMICS ET200PRO
130:	PM250D (SINAMICS G120D)
133:	SINAMICS G120C
135:	SINAMICS PMV40
136:	SINAMICS PMV60
137:	SINAMICS PMV80
138:	SINAMICS G110M
140:	SINAMICS G120X/G120XA
150:	SINAMICS G
151:	PM330 (SINAMICS G120)
200:	SINAMICS GM
250:	SINAMICS SM
260:	SINAMICS MC
300:	SINAMICS GL
350:	SINAMICS SL
400:	SINAMICS DCM

**Note**

For parallel circuit configurations, the parameter index is assigned to a power unit.

**r0204[0...n]**

**Power unit hardware properties / PU HW property**

<b>Access level:</b> 3	<b>Calculated:</b> -	<b>Data type:</b> Unsigned32
<b>Can be changed:</b> -	<b>Scaling:</b> -	<b>Dynamic index:</b> PDS, p0120
<b>Unit group:</b> -	<b>Unit selection:</b> -	<b>Function diagram:</b> -
<b>Min:</b>	<b>Max:</b>	<b>Factory setting:</b>
-	-	-

**Description:** Displays the properties supported by the power unit hardware.

<b>Bit field:</b>	<b>Bit</b>	<b>Signal name</b>	<b>1 signal</b>	<b>0 signal</b>	<b>FP</b>
	01	RFI filter available	Yes	No	-
	07	F3E regenerative feedback into the line supply	Yes	No	-
	08	Internal Braking Module	Yes	No	-
	12	Safe Brake Control (SBC) supported	No	Yes	-
	14	Internal LC output filter	Yes	No	-
	15	Line voltage	1-phase	3-phase	-

<b>p0205</b>	<b>Power unit application / PU application</b>		
	<b>Access level:</b> 1	<b>Calculated:</b> -	<b>Data type:</b> Integer16
	<b>Can be changed:</b> C2(1, 2)	<b>Scaling:</b> -	<b>Dynamic index:</b> -
	<b>Unit group:</b> -	<b>Unit selection:</b> -	<b>Function diagram:</b> -
	<b>Min:</b> 0	<b>Max:</b> 7	<b>Factory setting:</b> 0
<b>Description:</b>	The duty cycles can be overloaded provided that the drive converter is operated with its base load current before and after the overload. This is based on a load duty cycle of 300 s.		
<b>Value:</b>	0: Load duty cycle with high overload for vector drives 1: Load duty cycle with low overload for vector drives 6: S1 duty cycle (for internal use) 7: S6 duty cycle (for internal use)		
<b>Dependency:</b>	See also: r3996		
<b>NOTICE</b>			
The parameter value is not reset when the factory setting is restored (see p0010 = 30, p0970). When the power unit use is changed, short-term communication interruptions may occur.			
<b>Note</b>			
When the parameter is changed, all of the motor parameters (p0305 ... p0311), the technological application (p0500) and the control mode (p1300) are pre-assigned according to the selected application. The parameter has no influence when calculating the thermal overload. p0205 can only be changed to the settings that are saved in the power unit EEPROM.			

<b>p0205</b>	<b>Power unit application / PU application</b>		
CUG120X_PN (PM330)	<b>Access level:</b> 1	<b>Calculated:</b> -	<b>Data type:</b> Integer16
	<b>Can be changed:</b> C2(1, 2)	<b>Scaling:</b> -	<b>Dynamic index:</b> -
	<b>Unit group:</b> -	<b>Unit selection:</b> -	<b>Function diagram:</b> -
	<b>Min:</b> 0	<b>Max:</b> 1	<b>Factory setting:</b> 1
<b>Description:</b>	The duty cycles can be overloaded provided that the drive converter is operated with its base load current before and after the overload. This is based on a load duty cycle of 300 s.		
<b>Value:</b>	0: Load duty cycle with high overload for vector drives 1: Load duty cycle with low overload for vector drives		
<b>Dependency:</b>	See also: r3996		
<b>NOTICE</b>			
The parameter value is not reset when the factory setting is restored (see p0010 = 30, p0970). When the power unit use is changed, short-term communication interruptions may occur.			
<b>Note</b>			
When the parameter is changed, all of the motor parameters (p0305 ... p0311), the technological application (p0500) and the control mode (p1300) are pre-assigned according to the selected application. The parameter has no influence when calculating the thermal overload. p0205 can only be changed to the settings that are saved in the power unit EEPROM.			

<b>r0206[0...4]</b>	<b>Rated power unit power / PU P<sub>rated</sub></b>		
	<b>Access level:</b> 2	<b>Calculated:</b> -	<b>Data type:</b> FloatingPoint32
	<b>Can be changed:</b> -	<b>Scaling:</b> -	<b>Dynamic index:</b> -
	<b>Unit group:</b> 14_6	<b>Unit selection:</b> p0100	<b>Function diagram:</b> -
	<b>Min:</b> - [kW]	<b>Max:</b> - [kW]	<b>Factory setting:</b> - [kW]
<b>Description:</b>	Displays the rated power unit power for various load duty cycles.		

7.3 Parameter list

**Index:** [0] = Rated value  
 [1] = Load duty cycle with low overload  
 [2] = Load duty cycle with high overload  
 [3] = S1 cont duty cyc  
 [4] = S6 load duty cycle

**Dependency:** IECdrives (p0100 = 0): Units kW  
 NEMA drives (p0100 = 1): Units hp  
 See also: p0100, p0205

**r0207[0...4] Rated power unit current / PU PI\_rated**

<b>Access level:</b> 3	<b>Calculated:</b> -	<b>Data type:</b> FloatingPoint32
<b>Can be changed:</b> -	<b>Scaling:</b> -	<b>Dynamic index:</b> -
<b>Unit group:</b> -	<b>Unit selection:</b> -	<b>Function diagram:</b> 8021
<b>Min:</b> - [Arms]	<b>Max:</b> - [Arms]	<b>Factory setting:</b> - [Arms]

**Description:** Displays the rated power unit power for various load duty cycles.

**Index:** [0] = Rated value  
 [1] = Load duty cycle with low overload  
 [2] = Load duty cycle with high overload  
 [3] = S1 cont duty cyc  
 [4] = S6 load duty cycle

**Dependency:** See also: p0205

**r0207[0...4] Rated power unit current / PU PI\_rated**

CUG120X\_PN  
(PM330)

<b>Access level:</b> 3	<b>Calculated:</b> -	<b>Data type:</b> FloatingPoint32
<b>Can be changed:</b> -	<b>Scaling:</b> -	<b>Dynamic index:</b> -
<b>Unit group:</b> -	<b>Unit selection:</b> -	<b>Function diagram:</b> 8021
<b>Min:</b> - [Arms]	<b>Max:</b> - [Arms]	<b>Factory setting:</b> - [Arms]

**Description:** Displays the rated power unit power for various load duty cycles.

**Index:** [0] = Rated value  
 [1] = Load duty cycle with low overload  
 [2] = Load duty cycle with high overload  
 [3] = S1 cont duty cyc  
 [4] = S6 load duty cycle

**Dependency:** See also: p0205

**Note**  
 Wide voltage range device 500 V - 690 V:  
 The rated current displayed refers to a supply voltage of 500 V.

**r0208 Rated power unit line supply voltage / PU U\_rated**

<b>Access level:</b> 2	<b>Calculated:</b> -	<b>Data type:</b> FloatingPoint32
<b>Can be changed:</b> -	<b>Scaling:</b> -	<b>Dynamic index:</b> -
<b>Unit group:</b> -	<b>Unit selection:</b> -	<b>Function diagram:</b> -
<b>Min:</b> - [Vrms]	<b>Max:</b> - [Vrms]	<b>Factory setting:</b> - [Vrms]

**Description:** Displays the rated line supply voltage of the power unit.  
 r0208 = 400: 380 - 480 V +/-10 %  
 r0208 = 500: 500 - 600 V +/-10 %  
 r0208 = 690: 660 - 690 V +/-10 %

<b>r0209[0...4]</b>	<b>Power unit maximum current / PU I_max</b>		
	<b>Access level:</b> 3	<b>Calculated:</b> -	<b>Data type:</b> FloatingPoint32
	<b>Can be changed:</b> -	<b>Scaling:</b> -	<b>Dynamic index:</b> -
	<b>Unit group:</b> -	<b>Unit selection:</b> -	<b>Function diagram:</b> 8750, 8850, 8950
	<b>Min:</b> - [Arms]	<b>Max:</b> - [Arms]	<b>Factory setting:</b> - [Arms]
<b>Description:</b>	Displays the maximum output current of the power unit.		
<b>Index:</b>	[0] = Catalog [1] = Load duty cycle with low overload [2] = Load duty cycle with high overload [3] = S1 load duty cycle [4] = S6 load duty cycle		
<b>Dependency:</b>	See also: p0205		

<b>p0210</b>	<b>Drive unit line supply voltage / U_connect</b>		
	<b>Access level:</b> 3	<b>Calculated:</b> -	<b>Data type:</b> Unsigned16
	<b>Can be changed:</b> T	<b>Scaling:</b> -	<b>Dynamic index:</b> -
	<b>Unit group:</b> -	<b>Unit selection:</b> -	<b>Function diagram:</b> -
	<b>Min:</b> 1 [V]	<b>Max:</b> 63000 [V]	<b>Factory setting:</b> 400 [V]
<b>Description:</b>	Sets the drive unit supply voltage (rms value of the phase-to-phase line supply voltage).		
<b>Dependency:</b>	Set p1254, p1294 (automatic detection of the Vdc switch-on levels) = 0. The switch-in thresholds of the Vdc_max controller (r1242, r1282) are then directly determined using p0210.		

**NOTICE**

If, in the switched-off state (pulse inhibit), the supply voltage is higher than the entered value, the Vdc controller may be automatically deactivated in some cases to prevent the motor from accelerating the next time the system is switched on. In this case, an appropriate alarm A07401 is output.

**Note**

Setting ranges for p0210 as a function of the rated power unit voltage:

U<sub>rated</sub> = 400 V:

- p0210 = 380 ... 480 V

U<sub>rated</sub> = 690 V:

- p0210 = 500 ... 690 V

<b>p0230</b>	<b>Drive filter type motor side / Drv filt type mot</b>		
	<b>Access level:</b> 1	<b>Calculated:</b> -	<b>Data type:</b> Integer16
	<b>Can be changed:</b> C2(1, 2)	<b>Scaling:</b> -	<b>Dynamic index:</b> -
	<b>Unit group:</b> -	<b>Unit selection:</b> -	<b>Function diagram:</b> -
	<b>Min:</b> 0	<b>Max:</b> 4	<b>Factory setting:</b> 0
<b>Description:</b>	Sets the type of the filter at the motor side.		
<b>Value:</b>	0: No filter 1: Motor reactor 2: dv/dt filter 3: Sine-wave filter Siemens 4: Sine-wave filter third-party		

7.3 Parameter list

**Dependency:** The following parameters are influenced using p0230:  
 p0230 = 1:  
 --> p0233 (power unit, motor reactor) = filter inductance  
 p0230 = 3:  
 --> p0233 (power unit, motor reactor) = filter inductance  
 --> p0234 (power unit sine-wave filter capacitance) = filter capacitance  
 --> p0290 (power unit overload response) = inhibit pulse frequency reduction  
 --> p1082 (maximum speed) = Fmax filter / pole pair number  
 --> p1800 (pulse frequency) >= nominal pulse frequency of the filter  
 --> p1802 (modulator modes) = space vector modulation without overcontrol  
 p0230 = 4:  
 --> p0290 (power unit overload response) = inhibit pulse frequency reduction  
 --> p1802 (modulator modes) = space vector modulation without overcontrol  
 The user must set the following parameters according to the data sheet of the sine-wave filter and also the user must check whether they are permitted.  
 --> p0233 (power unit, motor reactor) = filter inductance  
 --> p0234 (power unit sine-wave filter capacitance) = filter capacitance  
 --> p1082 (maximum speed) = Fmax filter / pole pair number  
 --> p1800 (pulse frequency) >= nominal pulse frequency of the filter  
 See also: p0233, p0234, p0290, p1082, p1800, p1802

**Note**

The parameter cannot be changed if the power unit (e.g. PM260) is equipped with an internal sine-wave filter. For sine-wave filters, the test pulse evaluation to detect short-circuits is always deactivated. Only motor reactor filter type can be selected for a synchronous reluctance motor (RESM). If a filter type cannot be selected, then this filter type is not permitted for the power unit.  
 p0230 = 1:  
 Power units with output reactor are limited to output frequencies of 150 Hz.  
 p0230 = 3:  
 Power units with sine-wave filter are limited to output frequencies of 200 Hz.

<p><b>p0230</b>                  CUG120X_PN                  (PM330)</p>	<p><b>Drive filter type motor side / Drv filt type mot</b></p>	<p><b>Access level:</b> 1  <b>Can be changed:</b> C2(1, 2)  <b>Unit group:</b> -  <b>Min:</b>                  0  <b>Max:</b>                  2</p>	<p><b>Calculated:</b> -  <b>Scaling:</b> -  <b>Unit selection:</b> -  <b>Factory setting:</b>                  0</p>	<p><b>Data type:</b> Integer16  <b>Dynamic index:</b> -  <b>Function diagram:</b> -</p>
<p><b>Description:</b>  <b>Value:</b></p>	<p>Sets the type of the filter at the motor side.                  0: No filter                  1: Motor reactor                  2: dv/dt filter</p>			
<p><b>Dependency:</b></p>	<p>The following parameters are influenced using p0230:                  p0230 = 1:                  --&gt; p0233 (power unit, motor reactor) = filter inductance                  See also: p0233, p0234, p0290, p1082, p1800, p1802</p>			
	<p><b>Note</b>                  If a filter type cannot be selected, then this filter type is not permitted for the power unit.                  p0230 = 1:                  Power units with output reactor are limited to output frequencies of 150 Hz.</p>			



<b>r0231[0...1]</b>	<b>Power cable length maximum / Cable length max</b>		
	<b>Access level:</b> 3	<b>Calculated:</b> -	<b>Data type:</b> Unsigned16
<b>Description:</b>	<b>Can be changed:</b> -	<b>Scaling:</b> -	<b>Dynamic index:</b> -
	<b>Unit group:</b> -	<b>Unit selection:</b> -	<b>Function diagram:</b> -
<b>Index:</b>	<b>Min:</b>	<b>Max:</b>	<b>Factory setting:</b>
	- [m]	- [m]	- [m]
Displays the maximum permissible cable lengths between the drive unit and motor.			
[0] = Unshielded			
[1] = Shielded			
<b>Note</b>			
The display value is used to provide information for service and maintenance.			
<b>p0233</b>	<b>Power unit motor reactor / PU mot reactor</b>		
	<b>Access level:</b> 2	<b>Calculated:</b> -	<b>Data type:</b> FloatingPoint32
<b>Description:</b>	<b>Can be changed:</b> C2(1), T, U	<b>Scaling:</b> -	<b>Dynamic index:</b> -
	<b>Unit group:</b> -	<b>Unit selection:</b> -	<b>Function diagram:</b> -
<b>Dependency:</b>	<b>Min:</b>	<b>Max:</b>	<b>Factory setting:</b>
	0.000 [mH]	1000.000 [mH]	0.000 [mH]
Enter the inductance of a filter connected at the power unit output.			
This parameter is automatically pre-set when you select a filter via p0230 if a SIEMENS filter is defined for the power unit.			
See also: p0230			
<b>Note</b>			
When exiting the quick commissioning using p3900 = 1, the parameter value is set to the value of the defined SIEMENS filter or to zero. For this reason, the parameter value of a third-party filter only has to be entered outside the commissioning phase (p0010 = 0) and then the controller calculation (p0340 = 3) is carried out.			
The parameter cannot be changed if the power unit (e.g. PM260) is equipped with an internal sine-wave filter.			
<b>p0234</b>	<b>Power unit sine-wave filter capacitance / PU sine filter C</b>		
	<b>Access level:</b> 2	<b>Calculated:</b> -	<b>Data type:</b> FloatingPoint32
<b>Description:</b>	<b>Can be changed:</b> C2(1), T, U	<b>Scaling:</b> -	<b>Dynamic index:</b> -
	<b>Unit group:</b> -	<b>Unit selection:</b> -	<b>Function diagram:</b> -
<b>Dependency:</b>	<b>Min:</b>	<b>Max:</b>	<b>Factory setting:</b>
	0.000 [µF]	1000.000 [µF]	0.000 [µF]
Enters the capacitance of a sine-wave filter connected at the power unit output.			
This parameter is automatically pre-set when you select a filter via p0230 if a SIEMENS filter is defined for the power unit.			
See also: p0230			
<b>Note</b>			
The parameter value includes the sum of all of the capacitances of a phase connected in series (phase - ground).			
When exiting the quick commissioning using p3900 = 1, the parameter value is set to the value of the defined SIEMENS filter or to zero. For this reason, the parameter value of a third-party filter only has to be entered outside the commissioning phase (p0010 = 0).			
The parameter cannot be changed if the power unit (e.g. PM260) is equipped with an internal sine-wave filter.			

7.3 Parameter list

<b>p0235</b>	<b>Motor reactor in series number / L_mot in SeriesQty</b>		
	<b>Access level:</b> 2	<b>Calculated:</b> -	<b>Data type:</b> Unsigned8
	<b>Can be changed:</b> C2(1, 2)	<b>Scaling:</b> -	<b>Dynamic index:</b> -
	<b>Unit group:</b> -	<b>Unit selection:</b> -	<b>Function diagram:</b> -
	<b>Min:</b> 1	<b>Max:</b> 3	<b>Factory setting:</b> 1

**Description:** Sets the number of reactors connected in series at the power unit output.

**Dependency:** See also: p0230

**NOTICE**  
The reactor inductances should be the same.  
If the number of motor reactors connected in series does not correspond to this parameter value, then this can result in an unfavorable control behavior.

<b>r0238</b>	<b>Internal power unit resistance / PU R internal</b>		
	<b>Access level:</b> 3	<b>Calculated:</b> -	<b>Data type:</b> FloatingPoint32
	<b>Can be changed:</b> -	<b>Scaling:</b> -	<b>Dynamic index:</b> -
	<b>Unit group:</b> -	<b>Unit selection:</b> -	<b>Function diagram:</b> -
	<b>Min:</b> - [ohm]	<b>Max:</b> - [ohm]	<b>Factory setting:</b> - [ohm]

**Description:** Displays the internal resistance of the power unit (IGBT and line resistance).

<b>p0247</b> CUG120X_PN (PM330)	<b>Voltage measurement configuring / U_mes config</b>		
	<b>Access level:</b> 3	<b>Calculated:</b> -	<b>Data type:</b> Unsigned32
	<b>Can be changed:</b> T, U	<b>Scaling:</b> -	<b>Dynamic index:</b> -
	<b>Unit group:</b> -	<b>Unit selection:</b> -	<b>Function diagram:</b> -
	<b>Min:</b> -	<b>Max:</b> -	<b>Factory setting:</b> 0000 0000 0010 0000 bin

**Description:** Sets the configuration for the output voltage measurement of the power unit.

<b>Bit field:</b>	<b>Bit</b>	<b>Signal name</b>	<b>1 signal</b>	<b>0 signal</b>	<b>FP</b>
	00	Activate voltage measurement	Yes	No	-
	01	Siemens internal	Yes	No	-
	02	Siemens internal	Yes	No	-
	05	Use voltage measured values for flying restart	Yes	No	-
	07	Voltage calibration when switching on	Yes	No	-
	08	Voltage monitoring when switching on	Yes	No	-
	09	Voltage monitoring cyclic	Yes	No	-

**Note**  
The motor data identification must be executed when using the voltage measurement.

<b>p0251[0...n]</b> CUG120X_PN (PM330)	<b>Operating hours counter power unit fan / PU fan t_oper</b>		
	<b>Access level:</b> 3	<b>Calculated:</b> -	<b>Data type:</b> Unsigned32
	<b>Can be changed:</b> T	<b>Scaling:</b> -	<b>Dynamic index:</b> PDS, p0120
	<b>Unit group:</b> -	<b>Unit selection:</b> -	<b>Function diagram:</b> -
	<b>Min:</b> 0 [h]	<b>Max:</b> 4294967295 [h]	<b>Factory setting:</b> 0 [h]

**Description:** Displays the power unit fan operating hours.

The number of hours operated can only be reset to 0 in this parameter (e.g. after a fan has been replaced).

**Dependency:** See also: A30042

**Note**

For liquid-cooled chassis power units, the operating hours of the inner fan are displayed in p0251 and not in p0254.

<b>p0254[0...n]</b>	<b>Operating hours counter power unit fan inside the converter / PU inner fan t_op</b>		
CUG120X_PN (PM330)	<b>Access level:</b> 3	<b>Calculated:</b> -	<b>Data type:</b> Unsigned32
	<b>Can be changed:</b> T	<b>Scaling:</b> -	<b>Dynamic index:</b> PDS, p0120
	<b>Unit group:</b> -	<b>Unit selection:</b> -	<b>Function diagram:</b> -
	<b>Min:</b> 0 [h]	<b>Max:</b> 4294967295 [h]	<b>Factory setting:</b> 0 [h]
<b>Description:</b>	Displays the power unit fan operating hours of the internal fan in the power unit. The number of hours operated can only be reset to 0 in this parameter (e.g. after a fan has been replaced).		
<b>Dependency:</b>	See also: A30042		

**Note**

For liquid-cooled chassis power units, the operating hours of the inner fan are displayed in p0251 and not in p0254.

<b>p0287[0...1]</b>	<b>Ground fault monitoring thresholds / Gnd flt threshold</b>		
	<b>Access level:</b> 3	<b>Calculated:</b> -	<b>Data type:</b> FloatingPoint32
	<b>Can be changed:</b> T	<b>Scaling:</b> -	<b>Dynamic index:</b> -
	<b>Unit group:</b> -	<b>Unit selection:</b> -	<b>Function diagram:</b> -
	<b>Min:</b> 0.0 [%]	<b>Max:</b> 100.0 [%]	<b>Factory setting:</b> [0] 6.0 [%] [1] 16.0 [%]
<b>Description:</b>	Sets the shutdown thresholds for the ground fault monitoring. The setting is made as a percentage of the maximum current of the power unit (r0209).		
<b>Index:</b>	[0] = Threshold at which precharging starts [1] = Threshold at which precharging stops		
<b>Dependency:</b>	See also: p1901 See also: F30021		

**Note**

This parameter is only relevant for chassis power units.

<b>r0289</b>	<b>CO: Maximum power unit output current / PU I_outp max</b>		
	<b>Access level:</b> 3	<b>Calculated:</b> -	<b>Data type:</b> FloatingPoint32
	<b>Can be changed:</b> -	<b>Scaling:</b> p2002	<b>Dynamic index:</b> -
	<b>Unit group:</b> -	<b>Unit selection:</b> -	<b>Function diagram:</b> -
	<b>Min:</b> - [Arms]	<b>Max:</b> - [Arms]	<b>Factory setting:</b> - [Arms]
<b>Description:</b>	Displays the actual maximum output current of the power unit taking into account derating factors.		

<b>p0290</b>	<b>Power unit overload response / PU overld response</b>		
	<b>Access level:</b> 3	<b>Calculated:</b> -	<b>Data type:</b> Integer16
	<b>Can be changed:</b> T	<b>Scaling:</b> -	<b>Dynamic index:</b> -
	<b>Unit group:</b> -	<b>Unit selection:</b> -	<b>Function diagram:</b> 8021
	<b>Min:</b> 0	<b>Max:</b> 13	<b>Factory setting:</b> 2

7.3 Parameter list

**Description:** Sets the response to a thermal overload condition of the power unit.  
 The following quantities can result in a response to thermal overload:  
 - heat sink temperature (r0037[0]).  
 - chip temperature (r0037[1]).  
 - power unit overload I2t (r0036).  
 Possible measures to avoid thermal overload:  
 - reduce the output current limit r0289 and r0067 (for closed-loop speed control) or the output frequency (for U/f control indirectly via the output current limit and the intervention of the current limiting controller).  
 - reduce the pulse frequency.  
 A reduction, if parameterized, is always realized after an appropriate alarm is output.

**Value:**

0:	Reduce output current or output frequency
1:	No reduction shutdown when overload threshold is reached
2:	Reduce I_output or f_output and f_pulse (not using I2t)
3:	Reduce the pulse frequency (not using I2t)
12:	I_output or f_output and automatic pulse frequency reduction
13:	Automatic pulse frequency reduction

**Dependency:** If a sine-wave filter is parameterized as output filter (p0230 = 3, 4), then only responses can be selected without pulse frequency reduction (p0290 = 0, 1).  
 For a thermal power unit overload, an appropriate alarm or fault is output, and r2135.15 or r2135.13 set.  
 See also: r0036, r0037, p0230, r2135  
 See also: A05000, A05001, A07805

**NOTICE**  
 If the thermal overload of the power unit is not sufficiently reduced by the actions taken, the drive is always shut down. This means that the power unit is always protected irrespective of the setting of this parameter.

**Note**  
 The setting p0290 = 0, 2 is only practical if the load decreases with decreasing speed (e.g. for applications with variable torque such as for pumps and fans).  
 Under overload conditions, the current and torque limit are reduced, and therefore the motor is braked and forbidden speed ranges (e.g. minimum speed p1080 and suppression [skip] speeds p1091 ... p1094) can be passed through. For p0290 = 2, 3, 12, 13, the I2t overload detection of the power unit does not influence the response "Reduce pulse frequency".  
 When the motor data identification routine is selected, p0290 cannot be changed.  
 For short-circuit/ground fault detection, when the test pulse evaluation is active via p1901 "Test pulse evaluation configuration", the pulse frequency at the instant of switch on is briefly reduced.

**p0292[0...1]**

**Power unit temperature alarm threshold / PU T\_alm thresh**

<b>Access level:</b> 3	<b>Calculated:</b> -	<b>Data type:</b> FloatingPoint32
<b>Can be changed:</b> T, U	<b>Scaling:</b> -	<b>Dynamic index:</b> -
<b>Unit group:</b> -	<b>Unit selection:</b> -	<b>Function diagram:</b> 8021
<b>Min:</b> 0 [°C]	<b>Max:</b> 25 [°C]	<b>Factory setting:</b> [0] 5 [°C] [1] 15 [°C]

**Description:** Sets the alarm threshold for power unit overtemperatures. The value is set as a difference to the tripping (shutdown) temperature.  
 Drive:  
 If this threshold is exceeded, an overload alarm is generated and the system responds as parameterized in p0290.  
 Infeed:  
 When the threshold value is exceeded, only an overload alarm is output.

**Index:**  
 [0] = Overtemperature heat sink  
 [1] = Temperature rise power semiconductor (chip)

**Dependency:** See also: r0037, p0290  
 See also: A05000, A05001

<b>p0295</b>	<b>Fan run-on time / Fan run-on time</b>		
	<b>Access level:</b> 3	<b>Calculated:</b> -	<b>Data type:</b> FloatingPoint32
	<b>Can be changed:</b> T, U	<b>Scaling:</b> -	<b>Dynamic index:</b> -
	<b>Unit group:</b> -	<b>Unit selection:</b> -	<b>Function diagram:</b> -
	<b>Min:</b> 0 [s]	<b>Max:</b> 600 [s]	<b>Factory setting:</b> 0 [s]
<b>Description:</b>	Sets the fan run-on time after the pulses for the power unit have been canceled.		
	<b>Note</b>		
	- Under certain circumstances, the fan can continue to run for longer than was set (e.g. as a result of the excessively high heat sink temperature).		
	- For values less than 1 s, a 1 s run on time for the fan is active.		
	- for a PM230 power unit, sizes D - F the parameter is ineffective.		
<b>r0296</b>	<b>DC link voltage undervoltage threshold / Vdc U_lower_thresh</b>		
	<b>Access level:</b> 3	<b>Calculated:</b> -	<b>Data type:</b> Unsigned16
	<b>Can be changed:</b> -	<b>Scaling:</b> -	<b>Dynamic index:</b> -
	<b>Unit group:</b> -	<b>Unit selection:</b> -	<b>Function diagram:</b> -
	<b>Min:</b> - [V]	<b>Max:</b> - [V]	<b>Factory setting:</b> - [V]
<b>Description:</b>	Threshold to detect a DC link undervoltage. If the DC link voltage falls below this threshold, the drive unit is tripped due to a DC link undervoltage condition.		
<b>Dependency:</b>	See also: F30003		
<b>r0297</b>	<b>DC link voltage overvoltage threshold / Vdc U_upper_thresh</b>		
	<b>Access level:</b> 3	<b>Calculated:</b> -	<b>Data type:</b> Unsigned16
	<b>Can be changed:</b> -	<b>Scaling:</b> -	<b>Dynamic index:</b> -
	<b>Unit group:</b> -	<b>Unit selection:</b> -	<b>Function diagram:</b> 8750, 8760, 8850, 8864, 8950, 8964
	<b>Min:</b> - [V]	<b>Max:</b> - [V]	<b>Factory setting:</b> - [V]
<b>Description:</b>	Threshold to detect a DC link overvoltage. If the DC link voltage exceeds the threshold specified here, the drive unit is tripped due to DC link overvoltage.		
<b>Dependency:</b>	See also: F30002		
<b>p0300[0...n]</b>	<b>Motor type selection / Mot type sel</b>		
	<b>Access level:</b> 2	<b>Calculated:</b> -	<b>Data type:</b> Integer16
	<b>Can be changed:</b> C2(1, 3)	<b>Scaling:</b> -	<b>Dynamic index:</b> MDS, p0130
	<b>Unit group:</b> -	<b>Unit selection:</b> -	<b>Function diagram:</b> 6310
	<b>Min:</b> 0	<b>Max:</b> 603	<b>Factory setting:</b> 0

7.3 Parameter list

**Description:** Selecting the motor type.  
The first digit of the parameter value always defines the general motor type and corresponds to the third-party motor belonging to a motor list:  
1 = induction motor  
2 = synchronous motor  
6 = synchronous reluctance motor  
xx = motor without code number  
xxx = motor with code number  
The type information must be entered to filter motor-specific parameters and to optimize the operating characteristics and behavior. For example, for synchronous motors, power factor (p0308) is neither used nor displayed (in the BOP-2/IOP-2).  
The following applies for values < 100:  
Motor data must be manually entered.  
The following applies for values >= 100:  
Motor data are automatically loaded from an internal list.

**Value:**

0:	No motor
1:	Induction motor
2:	Synchronous motor
6:	Reluctance motor
10:	1LE1 induction motor (not a code number)
13:	1LG6 induction motor (not a code number)
17:	1LA7 induction motor (not a code number)
19:	1LA9 induction motor (not a code number)
100:	1LE1 induction motor
101:	1PC1 induction motor
105:	1LE5 induction motor
108:	1PH8 induction motor
600:	1FP1 synchronous reluctance motor
603:	1FP3 synchronous reluctance motor OEM

**Dependency:** When selecting p0300 = 10 ... 19, parameters p0335, p0626, p0627, and p0628 of the thermal motor model are pre-assigned as a function of p0307 and p0311.  
For p0096 = 1 (Standard Drive Control) synchronous motor types cannot be selected.

<b>CAUTION</b>
If a motor is selected, which is not contained in the motor lists (p0300 < 100), then the motor code number must be reset (p0301 = 0), if previously a motor was parameterized from the motor list.

<b>NOTICE</b>
If a catalog motor is selected (p0300 >= 100) and an associated motor code number (p0301), then the parameters that are associated with this list cannot be changed (write protection). The write protection is canceled if the motor type p0300 is set to a non-Siemens motor that matches p0301 (e.g. p0300 = 1 for p0301 = 1xxxx). Write protection is automatically canceled when the results of motor data identification are copied to the motor parameters. The motor type of a catalog motor corresponds to the upper three digits of the code number or the following assignment (if the particular motor type is listed): Type/code number ranges 100 / 100xx, 110xx, 120xx, 130xx, 140xx, 150xx 108 / 108xx, 118xx, 128xx, 138xx, 148xx, 158xx

**Note**  
Once the Control Unit has been switched on for the first time or if the factory settings have been defined accordingly, the motor type is preconfigured to induction motor (p0300 = 1).  
If a motor type has not been selected (p0300 = 0), then the drive commissioning routine cannot be exited.  
A motor type with a value above p0300 >= 100 describes motors for which a motor parameter list exists.

<b>p0300[0...n]</b>	<b>Motor type selection / Mot type sel</b>		
CUG120X_PN (PM330)	<b>Access level:</b> 2	<b>Calculated:</b> -	<b>Data type:</b> Integer16
	<b>Can be changed:</b> C2(1, 3)	<b>Scaling:</b> -	<b>Dynamic index:</b> MDS, p0130
	<b>Unit group:</b> -	<b>Unit selection:</b> -	<b>Function diagram:</b> 6310
	<b>Min:</b> 0	<b>Max:</b> 105	<b>Factory setting:</b> 0
<b>Description:</b>	<p>Selecting the motor type.</p> <p>The first digit of the parameter value always defines the general motor type and corresponds to the third-party motor belonging to a motor list:</p> <p>1 = induction motor 2 = synchronous motor xx = motor without code number xxx = motor with code number</p> <p>The type information must be entered to filter motor-specific parameters and to optimize the operating characteristics and behavior. For example, for synchronous motors, power factor (p0308) is neither used nor displayed (in the BOP/ IOP).</p> <p>The following applies for values &lt; 100: Motor data must be manually entered.</p> <p>The following applies for values &gt;= 100: Motor data are automatically loaded from an internal list.</p>		
<b>Value:</b>	<p>0: No motor</p> <p>1: Induction motor</p> <p>2: Synchronous motor</p> <p>10: 1LE1 induction motor (not a code number)</p> <p>13: 1LG6 induction motor (not a code number)</p> <p>14: 1xx1 SIMOTICS FD induction motor (not a code number)</p> <p>17: 1LA7 induction motor (not a code number)</p> <p>18: 1LA8 / 1PQ8 standard induction motor series</p> <p>19: 1LA9 induction motor (not a code number)</p> <p>100: 1LE1 induction motor</p> <p>105: 1LE5 induction motor</p>		
<b>Dependency:</b>	<p>When the motor type is changed, the code number in p0301 may be reset to 0.</p> <p>When selecting p0300 = 10 ... 19, parameters p0335, p0626, p0627, and p0628 of the thermal motor model are pre-assigned as a function of p0307 and p0311.</p>		
<b>⚠ CAUTION</b>			
If a motor is selected, which is not contained in the motor lists (p0300 < 100), then the motor code number must be reset (p0301 = 0), if previously a motor was parameterized from the motor list.			
<b>NOTICE</b>			
<p>If a catalog motor is selected (p0300 &gt;= 100) and an associated motor code number (p0301), then the parameters that are associated with this list cannot be changed (write protection). The write protection is canceled if the motor type p0300 is set to a non-Siemens motor that matches p0301 (e.g. p0300 = 1 for p0301 = 1xxxx). Write protection is automatically canceled when the results of motor data identification are copied to the motor parameters.</p> <p>The motor type of a catalog motor corresponds to the upper three digits of the code number or the following assignment (if the particular motor type is listed):</p> <p>Type/code number ranges 100 / 100xx, 110xx, 120xx, 130xx, 140xx, 150xx</p>			
<b>Note</b>			
<p>Once the Control Unit has been switched on for the first time or if the factory settings have been defined accordingly, the motor type is preconfigured to induction motor (p0300 = 1).</p> <p>If a motor type has not been selected (p0300 = 0), then the drive commissioning routine cannot be exited.</p> <p>A motor type with a value above p0300 &gt;= 100 describes motors for which a motor parameter list exists.</p>			

<b>p0301[0...n]</b>	<b>Motor code number selection / Mot code No. sel</b>		
	<b>Access level:</b> 2	<b>Calculated:</b> -	<b>Data type:</b> Unsigned16
	<b>Can be changed:</b> C2(1, 3)	<b>Scaling:</b> -	<b>Dynamic index:</b> MDS, p0130
	<b>Unit group:</b> -	<b>Unit selection:</b> -	<b>Function diagram:</b> -
	<b>Min:</b> 0	<b>Max:</b> 65535	<b>Factory setting:</b> 0
<b>Description:</b>	The parameter is used to select a motor from a motor parameter list. When changing the code number (with the exception to the value 0), all of the motor parameters are pre-assigned from the internally available parameter lists.		
<b>Dependency:</b>	Code numbers can only be selected for motor types that correspond to the motor type selected in p0300. See also: p0300		
	<b>Note</b> The motor code number can only be changed if the matching catalog motor was first selected in p0300. When selecting a catalog motor (p0300 >= 100), drive commissioning can only be exited if a code number is selected. If a change is made to a non-catalog motor, then the motor code number should be reset (p0301 = 0).		
<b>p0304[0...n]</b>	<b>Rated motor voltage / Mot U<sub>rated</sub></b>		
	<b>Access level:</b> 1	<b>Calculated:</b> -	<b>Data type:</b> FloatingPoint32
	<b>Can be changed:</b> C2(1, 3)	<b>Scaling:</b> -	<b>Dynamic index:</b> MDS, p0130
	<b>Unit group:</b> -	<b>Unit selection:</b> -	<b>Function diagram:</b> 6301, 6724
	<b>Min:</b> 0 [Vrms]	<b>Max:</b> 20000 [Vrms]	<b>Factory setting:</b> 0 [Vrms]
<b>Description:</b>	Sets the rated motor voltage (rating plate).		
	<b>NOTICE</b> When selecting a catalog motor (p0301), this parameter is automatically pre-assigned and is write protected. Information in p0300 should be carefully observed when removing write protection.		
	<b>Note</b> When the parameter value is entered the connection type of the motor (star-delta) must be taken into account. Once the Control Unit has booted for the first time or if the factory settings have been restored, the parameter is pre-assigned to match the power unit.		
<b>p0305[0...n]</b>	<b>Rated motor current / Mot I<sub>rated</sub></b>		
	<b>Access level:</b> 1	<b>Calculated:</b> -	<b>Data type:</b> FloatingPoint32
	<b>Can be changed:</b> C2(1, 3)	<b>Scaling:</b> -	<b>Dynamic index:</b> MDS, p0130
	<b>Unit group:</b> -	<b>Unit selection:</b> -	<b>Function diagram:</b> 6301
	<b>Min:</b> 0.00 [Arms]	<b>Max:</b> 10000.00 [Arms]	<b>Factory setting:</b> 0.00 [Arms]
<b>Description:</b>	Sets the rated motor current (rating plate).		
	<b>NOTICE</b> When selecting a catalog motor (p0301), this parameter is automatically pre-assigned and is write protected. Information in p0300 should be carefully observed when removing write protection. If p0305 is changed during quick commissioning (p0010 = 1), then the maximum current p0640 is pre-assigned accordingly.		
	<b>Note</b> When the parameter value is entered the connection type of the motor (star-delta) must be taken into account. Once the Control Unit has booted for the first time or if the factory settings have been restored, the parameter is pre-assigned to match the power unit.		



<b>p0306[0...n]</b>	<b>Number of motors connected in parallel / Motor qty</b>		
	<b>Access level:</b> 1	<b>Calculated:</b> -	<b>Data type:</b> Unsigned8
	<b>Can be changed:</b> C2(1, 3)	<b>Scaling:</b> -	<b>Dynamic index:</b> MDS, p0130
	<b>Unit group:</b> -	<b>Unit selection:</b> -	<b>Function diagram:</b> -
	<b>Min:</b> 1	<b>Max:</b> 50	<b>Factory setting:</b> 1
<b>Description:</b>	Sets the number (count) of motors that can be operated in parallel using one motor data set. Depending on the motor number entered, internally an equivalent motor is calculated. The following should be observed in motors connected in parallel: Rating plate data should only be entered for one motor: p0305, p0307 The following parameters are also only valid for one motor: p0320, p0341, p0344, p0350 ... p0361 All other motor parameters take into account the replacement/equivalent motor (e.g. r0331, r0333).		
<b>Recommendation:</b>	For motors connected in parallel, external thermal protection should be provided for each individual motor.		
<b>Dependency:</b>	See also: r0331		
<p><b>⚠ CAUTION</b></p> <p>The motors to be connected in parallel must be of the same type and size (same order no. (MLFB)). The mounting regulations when connecting motors in parallel must be carefully maintained! The number of motors set must correspond to the number of motors that are actually connected in parallel. After changing p0306, it is imperative that the control parameters are adapted (e.g. using automatic calculation with p0340 = 1, p3900 &gt; 0). For induction motors that are connected in parallel, but which are not mechanically coupled with one another, then the following applies: - an individual motor must not be loaded beyond its stall point.</p>			
<p><b>NOTICE</b></p> <p>If p0306 is changed during quick commissioning (p0010 = 1), then the maximum current p0640 is appropriately pre-assigned.</p>			
<b>Note</b>			
Only operation with U/f characteristic makes sense if more than 10 identical motors are connected in parallel.			
<b>p0307[0...n]</b>	<b>Rated motor power / Mot P<sub>rated</sub></b>		
	<b>Access level:</b> 1	<b>Calculated:</b> -	<b>Data type:</b> FloatingPoint32
	<b>Can be changed:</b> C2(1, 3)	<b>Scaling:</b> -	<b>Dynamic index:</b> MDS, p0130
	<b>Unit group:</b> 14_6	<b>Unit selection:</b> p0100	<b>Function diagram:</b> -
	<b>Min:</b> 0.00 [kW]	<b>Max:</b> 100000.00 [kW]	<b>Factory setting:</b> 0.00 [kW]
<b>Description:</b>	Sets the rated motor power (rating plate).		
<b>Dependency:</b>	IECdrives (p0100 = 0): Units kW NEMA drives (p0100 = 1): Units hp NEMA drives (p0100 = 2): Unit kW See also: p0100		
<p><b>NOTICE</b></p> <p>When selecting a catalog motor (p0301), this parameter is automatically pre-assigned and is write protected. Information in p0300 should be carefully observed when removing write protection.</p>			
<b>Note</b>			
Once the Control Unit has booted for the first time or if the factory settings have been restored, the parameter is pre-assigned to match the power unit.			

<b>p0308[0...n]</b>	<b>Rated motor power factor / Mot cos phi rated</b>		
	<b>Access level:</b> 1	<b>Calculated:</b> -	<b>Data type:</b> FloatingPoint32
	<b>Can be changed:</b> C2(1, 3)	<b>Scaling:</b> -	<b>Dynamic index:</b> MDS, p0130
	<b>Unit group:</b> -	<b>Unit selection:</b> -	<b>Function diagram:</b> -
	<b>Min:</b> 0.000	<b>Max:</b> 1.000	<b>Factory setting:</b> 0.000
<b>Description:</b>	Sets the rated motor power factor (cos phi, rating plate). For a parameter value of 0.000, the power factor is internally calculated and displayed in r0332.		
<b>Dependency:</b>	This parameter is only available for p0100 = 0, 2. See also: p0100, p0309, r0332		
<b>NOTICE</b>			
When selecting a catalog motor (p0301), this parameter is automatically pre-assigned and is write protected. Information in p0300 should be carefully observed when removing write protection.			
<b>Note</b>			
The parameter is not used for synchronous motors (p0300 = 2xx). Once the Control Unit has booted for the first time or if the factory settings have been restored, the parameter is pre-assigned to match the power unit.			
<b>p0309[0...n]</b>	<b>Rated motor efficiency / Mot eta_rated</b>		
	<b>Access level:</b> 1	<b>Calculated:</b> -	<b>Data type:</b> FloatingPoint32
	<b>Can be changed:</b> C2(1, 3)	<b>Scaling:</b> -	<b>Dynamic index:</b> MDS, p0130
	<b>Unit group:</b> -	<b>Unit selection:</b> -	<b>Function diagram:</b> -
	<b>Min:</b> 0.0 [%]	<b>Max:</b> 99.9 [%]	<b>Factory setting:</b> 0.0 [%]
<b>Description:</b>	Sets the rated motor efficiency (rating plate). For a parameter value of 0.0, the power factor is internally calculated and displayed in r0332.		
<b>Dependency:</b>	This parameter is only visible for NEMA motors (p0100 = 1, 2). See also: p0100, p0308, r0332		
<b>Note</b>			
The parameter is not used for synchronous motors.			
<b>p0310[0...n]</b>	<b>Rated motor frequency / Mot f_rated</b>		
	<b>Access level:</b> 1	<b>Calculated:</b> -	<b>Data type:</b> FloatingPoint32
	<b>Can be changed:</b> C2(1, 3)	<b>Scaling:</b> -	<b>Dynamic index:</b> MDS, p0130
	<b>Unit group:</b> -	<b>Unit selection:</b> -	<b>Function diagram:</b> 6301
	<b>Min:</b> 0.00 [Hz]	<b>Max:</b> 650.00 [Hz]	<b>Factory setting:</b> 0.00 [Hz]
<b>Description:</b>	Sets the rated motor frequency (rating plate).		
<b>Dependency:</b>	The number of pole pairs (r0313) is automatically re-calculated when the parameter is changed (together with p0311), if p0314 = 0. The rated frequency is restricted to values between 1.00 Hz and 650.00 Hz. See also: p0311, r0313		
<b>NOTICE</b>			
When selecting a catalog motor (p0301), this parameter is automatically pre-assigned and is write protected. Information in p0300 should be carefully observed when removing write protection. If p0310 is changed during quick commissioning (p0010 = 1), the maximum speed p1082, which is also associated with quick commissioning, is pre-assigned accordingly. The pre-assignment has been completed if the status display r3996 returns to zero.			

**Note**

Once the Control Unit has been booted up for the first time or if the factory settings have been defined accordingly, the parameter is defined in accordance with the power unit.

**p0310[0...n]**

CUG120X\_PN  
(PM330)

**Rated motor frequency / Mot f<sub>rated</sub>****Access level:** 1**Can be changed:** C2(1, 3)**Unit group:** -**Min:**

0.00 [Hz]

**Calculated:** -**Scaling:** -**Unit selection:** -**Max:**

103.00 [Hz]

**Data type:** FloatingPoint32**Dynamic index:** MDS, p0130**Function diagram:** 6301**Factory setting:**

0.00 [Hz]

**Description:**

Sets the rated motor frequency (rating plate).

**Dependency:**

The number of pole pairs (r0313) is automatically re-calculated when the parameter is changed (together with p0311), if p0314 = 0.

The rated frequency is restricted to values between 1.00 Hz and 100.00 Hz.

See also: p0311, r0313

**NOTICE**

When selecting a catalog motor (p0301), this parameter is automatically pre-assigned and is write protected. Information in p0300 should be carefully observed when removing write protection.

If p0310 is changed during quick commissioning (p0010 = 1), the maximum speed p1082, which is also associated with quick commissioning, is pre-assigned accordingly. The pre-assignment has been completed if the status display r3996 returns to zero.

**Note**

Once the Control Unit has been booted up for the first time or if the factory settings have been defined accordingly, the parameter is defined in accordance with the power unit.

**p0311[0...n]****Rated motor speed / Mot n<sub>rated</sub>****Access level:** 1**Can be changed:** C2(1, 3)**Unit group:** -**Min:**

0.0 [rpm]

**Calculated:** -**Scaling:** -**Unit selection:** -**Max:**

210000.0 [rpm]

**Data type:** FloatingPoint32**Dynamic index:** MDS, p0130**Function diagram:** -**Factory setting:**

0.0 [rpm]

**Description:**

Sets the rated motor speed (rating plate).

For p0311 = 0, the rated motor slip of induction motors is internally calculated and displayed in r0330.

It is especially important to correctly enter the rated motor speed for vector control and slip compensation for U/f control.

**Dependency:**

If p0311 is changed and for p0314 = 0, the pole pair (r0313) is re-calculated automatically.

See also: p0310, r0313

**NOTICE**

When selecting a catalog motor (p0301), this parameter is automatically pre-assigned and is write protected. Information in p0300 should be carefully observed when removing write protection.

If p0311 is changed during quick commissioning (p0010 = 1), the maximum speed p1082, which is also associated with quick commissioning, is pre-assigned accordingly. The pre-assignment has been completed if the status display r3996 returns to zero.

**Note**

Once the Control Unit has been booted up for the first time or if the factory settings have been defined accordingly, the parameter is defined in accordance with the power unit.

<b>r0313[0...n]</b>	<b>Motor pole pair number, actual (or calculated) / Mot PolePairNo act</b>		
	<b>Access level:</b> 3	<b>Calculated:</b> -	<b>Data type:</b> Unsigned16
	<b>Can be changed:</b> -	<b>Scaling:</b> -	<b>Dynamic index:</b> MDS, p0130
	<b>Unit group:</b> -	<b>Unit selection:</b> -	<b>Function diagram:</b> 5300
	<b>Min:</b> -	<b>Max:</b> -	<b>Factory setting:</b> -
<b>Description:</b>	Displays the number of motor pole pairs. The value is used for internal calculations. r0313 = 1: 2-pole motor r0313 = 2: 4-pole motor, etc.		
<b>Dependency:</b>	For p0314 > 0, the entered value is displayed in r0313. For p0314 = 0, the pole pair number (r0313) is automatically calculated from the rated power (p0307), rated frequency (p0310) and rated speed (p0311). See also: p0307, p0310, p0311		
	<b>Note</b> For the automatic calculation, the pole pair number is set to the value of 2 if the rated speed or the rated frequency is zero.		
<b>p0316[0...n]</b>	<b>Motor torque constant / Mot kT</b>		
	<b>Access level:</b> 3	<b>Calculated:</b> -	<b>Data type:</b> FloatingPoint32
	<b>Can be changed:</b> C2(1), T, U	<b>Scaling:</b> -	<b>Dynamic index:</b> MDS, p0130
	<b>Unit group:</b> 28_1	<b>Unit selection:</b> p0100	<b>Function diagram:</b> -
	<b>Min:</b> 0.00 [Nm/A]	<b>Max:</b> 400.00 [Nm/A]	<b>Factory setting:</b> 0.00 [Nm/A]
<b>Description:</b>	Sets the torque constant of the synchronous motor. p0316 = 0: The torque constant is calculated from the motor data. p0316 > 0: The selected value is used as torque constant.		
	<b>NOTICE</b> When selecting a catalog motor (p0301), this parameter is automatically pre-assigned and is write protected. Information in p0300 should be carefully observed when removing write protection.		
	<b>Note</b> This parameter is not used for induction motors (p0300 = 1xx).		
<b>p0320[0...n]</b>	<b>Motor rated magnetizing current/short-circuit current / Mot I_mag_rated</b>		
	<b>Access level:</b> 3	<b>Calculated:</b> -	<b>Data type:</b> FloatingPoint32
	<b>Can be changed:</b> T, U	<b>Scaling:</b> -	<b>Dynamic index:</b> MDS, p0130
	<b>Unit group:</b> -	<b>Unit selection:</b> -	<b>Function diagram:</b> -
	<b>Min:</b> 0.000 [Arms]	<b>Max:</b> 5000.000 [Arms]	<b>Factory setting:</b> 0.000 [Arms]
<b>Description:</b>	Induction motors: Sets the rated motor magnetizing current. For p0320 = 0.000 the magnetizing current is internally calculated and displayed in r0331. Synchronous motors: Sets the rated motor short-circuit current.		
	<b>NOTICE</b> When selecting a catalog motor (p0301), this parameter is automatically pre-assigned and is write protected. Information in p0300 should be carefully observed when removing write protection.		

**Note**

The magnetizing current p0320 for induction motors is reset when quick commissioning is exited with p3900 > 0. If, for induction motors, the magnetizing current p0320 is changed outside the commissioning phase (p0010 > 0), then the magnetizing inductance p0360 is changed so that the EMF r0337 remains constant.

<b>p0322[0...n]</b>	<b>Maximum motor speed / Mot n_max</b>		
	<b>Access level:</b> 1	<b>Calculated:</b> -	<b>Data type:</b> FloatingPoint32
	<b>Can be changed:</b> C2(1, 3)	<b>Scaling:</b> -	<b>Dynamic index:</b> MDS, p0130
	<b>Unit group:</b> -	<b>Unit selection:</b> -	<b>Function diagram:</b> -
	<b>Min:</b> 0.0 [rpm]	<b>Max:</b> 210000.0 [rpm]	<b>Factory setting:</b> 0.0 [rpm]
<b>Description:</b>	Sets the maximum motor speed.		
<b>Dependency:</b>	See also: p1082		
<b>NOTICE</b>			
When selecting a catalog motor (p0301), this parameter is automatically pre-assigned and is write protected. Information in p0300 should be carefully observed when removing write protection.			
If p0322 is changed during quick commissioning (p0010 = 1), the maximum speed p1082, which is also associated with quick commissioning, is pre-assigned accordingly.			
<b>Note</b>			
The parameter has no significance for a value of p0322 = 0.			

<b>p0323[0...n]</b>	<b>Maximum motor current / Mot I_max</b>		
	<b>Access level:</b> 1	<b>Calculated:</b> -	<b>Data type:</b> FloatingPoint32
	<b>Can be changed:</b> C2(1, 3)	<b>Scaling:</b> -	<b>Dynamic index:</b> MDS, p0130
	<b>Unit group:</b> -	<b>Unit selection:</b> -	<b>Function diagram:</b> -
	<b>Min:</b> 0.00 [Arms]	<b>Max:</b> 20000.00 [Arms]	<b>Factory setting:</b> 0.00 [Arms]
<b>Description:</b>	Sets the maximum permissible motor current (e.g. de-magnetizing current for synchronous motors).		
<b>NOTICE</b>			
When selecting a catalog motor (p0301), this parameter is automatically pre-assigned and is write protected. Information in p0300 should be carefully observed when removing write protection.			
If p0323 is changed during quick commissioning (p0010 = 1), then the maximum current p0640 is pre-assigned accordingly.			
<b>Note</b>			
The parameter has no effect for induction motors.			
The parameter has no effect for synchronous motors if a value of 0.0 is entered. The user-selectable current limit is entered into p0640.			

<b>p0325[0...n]</b>	<b>Motor pole position identification current 1st phase / Mot PolID I 1st Ph</b>		
	<b>Access level:</b> 3	<b>Calculated:</b> -	<b>Data type:</b> FloatingPoint32
	<b>Can be changed:</b> T, U	<b>Scaling:</b> -	<b>Dynamic index:</b> MDS, p0130
	<b>Unit group:</b> -	<b>Unit selection:</b> -	<b>Function diagram:</b> -
	<b>Min:</b> 0.000 [Arms]	<b>Max:</b> 10000.000 [Arms]	<b>Factory setting:</b> 0.000 [Arms]
<b>Description:</b>	Sets the current for the 1st phase of the two-stage technique for pole position identification routine. The current of the 2nd phase is set in p0329.		
	The two-stage technique is selected with p1980 = 4.		
<b>Dependency:</b>	See also: p0329, p1980, r1992		

7.3 Parameter list

**NOTICE**  
 When the motor code (p0301) is changed, it is possible that p0325 is not pre-assigned.  
 p0325 can be pre-assigned using p0340 = 3.

**Note**

The value is automatically pre-assigned for the following events:  
 - For p0325 = 0 and automatic calculation of the closed-loop control parameters (p0340 = 1, 2, 3).  
 - for quick commissioning (p3900 = 1, 2, 3).

**p0327[0...n]**

**Optimum motor load angle / Mot phi\_load opt**

<b>Access level:</b> 3	<b>Calculated:</b> -	<b>Data type:</b> FloatingPoint32
<b>Can be changed:</b> T, U	<b>Scaling:</b> -	<b>Dynamic index:</b> MDS, p0130
<b>Unit group:</b> -	<b>Unit selection:</b> -	<b>Function diagram:</b> 6721, 6838
<b>Min:</b> 0.0 [°]	<b>Max:</b> 135.0 [°]	<b>Factory setting:</b> 90.0 [°]

**Description:** Sets the optimum load angle for synchronous motors with reluctance torque.  
 The load angle is measured at the rated motor current.

**NOTICE**  
 When selecting a catalog motor (p0301), this parameter is automatically pre-assigned and is write protected.  
 Information in p0300 should be carefully observed when removing write protection.

**Note**

This parameter has no significance for induction motors.  
 For synchronous motors without reluctance torque, a angle of 90 degrees must be set.  
 When quick commissioning is exited with p3900 > 0, then the parameter is reset if a catalog motor has not been selected (p0300).

**p0329[0...n]**

**Motor pole position identification current / Mot PolID current**

<b>Access level:</b> 3	<b>Calculated:</b> -	<b>Data type:</b> FloatingPoint32
<b>Can be changed:</b> T, U	<b>Scaling:</b> -	<b>Dynamic index:</b> MDS, p0130
<b>Unit group:</b> -	<b>Unit selection:</b> -	<b>Function diagram:</b> -
<b>Min:</b> 0.0000 [Arms]	<b>Max:</b> 10000.0000 [Arms]	<b>Factory setting:</b> 0.0000 [Arms]

**Description:** Sets the current for the pole position identification routine (p1980 = 1).  
 For a two-stage technique (p1980 = 4), the current is set for the 2nd phase.  
 The current for the 1st phase is set in p0325.

**Dependency:** The following applies for vector drives:  
 If a maximum current (p0323) was not parameterized, then p0329 is limited to the rated motor current.  
 See also: p0325, p1980, r1992

**NOTICE**  
 When selecting a catalog motor (p0301), this parameter is automatically pre-assigned and is write protected.  
 Information in p0300 should be carefully observed when removing write protection.

**r0330[0...n]**

**Rated motor slip / Mot slip Rated**

<b>Access level:</b> 3	<b>Calculated:</b> -	<b>Data type:</b> FloatingPoint32
<b>Can be changed:</b> -	<b>Scaling:</b> -	<b>Dynamic index:</b> MDS, p0130
<b>Unit group:</b> -	<b>Unit selection:</b> -	<b>Function diagram:</b> -
<b>Min:</b> - [Hz]	<b>Max:</b> - [Hz]	<b>Factory setting:</b> - [Hz]

**Description:** Displays the rated motor slip.

**Dependency:** The rated slip is calculated from the rated frequency, rated speed and number of pole pairs.  
See also: p0310, p0311, r0313

**Note**

The parameter is not used for synchronous motors (p0300 = 2xx).

---

**r0331[0...n]**      **Actual motor magnetizing current/short-circuit current / Mot I\_mag\_rtd act**

<b>Access level:</b> 3	<b>Calculated:</b> -	<b>Data type:</b> FloatingPoint32
<b>Can be changed:</b> -	<b>Scaling:</b> -	<b>Dynamic index:</b> MDS, p0130
<b>Unit group:</b> -	<b>Unit selection:</b> -	<b>Function diagram:</b> 6722
<b>Min:</b>	<b>Max:</b>	<b>Factory setting:</b>
- [Arms]	- [Arms]	- [Arms]

**Description:** Induction motor:  
Displays the rated magnetizing current from p0320.  
For p0320 = 0, the internally calculated magnetizing current is displayed.  
Synchronous motor:  
Displays the rated short-circuit current from p0320.

**Dependency:** If p0320 was not entered, then the parameter is calculated from the rating plate parameters.

---

**r0332[0...n]**      **Rated motor power factor / Mot cos phi rated**

<b>Access level:</b> 3	<b>Calculated:</b> -	<b>Data type:</b> FloatingPoint32
<b>Can be changed:</b> -	<b>Scaling:</b> -	<b>Dynamic index:</b> MDS, p0130
<b>Unit group:</b> -	<b>Unit selection:</b> -	<b>Function diagram:</b> -
<b>Min:</b>	<b>Max:</b>	<b>Factory setting:</b>
-	-	-

**Description:** Displays the rated power factor for induction motors.  
For IEC motors, the following applies (p0100 = 0):  
For p0308 = 0, the internally calculated power factor is displayed.  
For p0308 > 0, this value is displayed.  
For NEMA motors, the following applies (p0100 = 1, 2):  
For p0309 = 0, the internally calculated power factor is displayed.  
For p0309 > 0, this value is converted into the power factor and displayed.

**Dependency:** If p0308 is not entered, the parameter is calculated from the rating plate parameters.

**Note**  
The parameter is not used for synchronous motors (p0300 = 2xx).

---

**r0333[0...n]**      **Rated motor torque / Mot M\_rated**

<b>Access level:</b> 3	<b>Calculated:</b> -	<b>Data type:</b> FloatingPoint32
<b>Can be changed:</b> -	<b>Scaling:</b> -	<b>Dynamic index:</b> MDS, p0130
<b>Unit group:</b> 7_4	<b>Unit selection:</b> p0100	<b>Function diagram:</b> -
<b>Min:</b>	<b>Max:</b>	<b>Factory setting:</b>
- [Nm]	- [Nm]	- [Nm]

**Description:** Displays the rated motor torque.

**Dependency:** IEC drives (p0100 = 0): unit Nm  
NEMA drives (p0100 = 1): unit lbf ft

**Note**  
For induction motors, r0333 is calculated from p0307 and p0311.  
For synchronous motors, r0333 is calculated from p0305, p0316, p0327 and p0328.

7.3 Parameter list

<b>p0335[0...n]</b>	<b>Motor cooling type / Mot cool type</b>		
	<b>Access level:</b> 2	<b>Calculated:</b> -	<b>Data type:</b> Integer16
	<b>Can be changed:</b> C2(1), T	<b>Scaling:</b> -	<b>Dynamic index:</b> MDS, p0130
	<b>Unit group:</b> -	<b>Unit selection:</b> -	<b>Function diagram:</b> -
	<b>Min:</b> 0	<b>Max:</b> 128	<b>Factory setting:</b> 0

**Description:** Sets the motor cooling system used.

- Value:**
- 0: Natural ventilation
  - 1: Forced cooling
  - 2: Liquid cooling
  - 128: No fan

**Dependency:** For 1LA7 motors (p0300), the parameter is pre-set as a function of p0307 and p0311.

**NOTICE**  
When selecting a catalog motor (p0301), this parameter is automatically pre-assigned and is write protected. Information in p0300 should be carefully observed when removing write protection.

**Note**  
The parameter influences the thermal 3-mass motor model.  
1LA7 motors, frame size 56 are operated without fan.

<b>p0340[0...n]</b>	<b>Automatic calculation motor/control parameters / Calc auto par</b>		
	<b>Access level:</b> 2	<b>Calculated:</b> -	<b>Data type:</b> Integer16
	<b>Can be changed:</b> T	<b>Scaling:</b> -	<b>Dynamic index:</b> DDS, p0180
	<b>Unit group:</b> -	<b>Unit selection:</b> -	<b>Function diagram:</b> -
	<b>Min:</b> 0	<b>Max:</b> 5	<b>Factory setting:</b> 0

**Description:** Setting to automatically calculate motor parameters and U/f open-loop and closed-loop control parameters from the rating plate data.

- Value:**
- 0: No calculation
  - 1: Complete calculation
  - 2: Calculation of equivalent circuit diagram parameters
  - 3: Calculation of closed-loop control parameters
  - 4: Calculation of controller parameters
  - 5: Calculation of technological limits and threshold values



NOTICE
<p>After the value has been modified, no further parameter modifications can be made and the status is shown in r3996. Modifications can be made again when r3996 = 0.</p> <p>The following parameters are influenced using p0340:</p> <p>p0340 = 1:  --&gt; All of the parameters influenced for p0340 = 2, 3, 4, 5  --&gt; p0341, p0342, p0344, p0612, p0640, p1082, p1231, p1232, p1333, p1349, p1611, p1654, p1726, p1825, p1828 ... p1832, p1909, p1959, p2000, p2001, p2002, p2003, p3927, p3928</p> <p>p0340 = 2:  --&gt; p0350, p0354 ... p0360  --&gt; p0625 (matching p0350), p0626 ... p0628</p> <p>p0340 = 3:  --&gt; All of the parameters influenced for p0340 = 4, 5  --&gt; p0346, p0347, p0622, p1320 ... p1327, p1582, p1584, p1616, p1755, p1756, p2178</p> <p>p0340 = 4:  --&gt; p1290, p1292, p1293, p1338, p1339, p1340, p1341, p1345, p1346, p1461, p1463, p1464, p1465, p1470, p1472, p1703, p1715, p1717, p1740, p1756, p1764, p1767, p1780, p1781, p1783, p1785, p1786, p1795</p> <p>p0340 = 5:  --&gt; p1037, p1038, p1520, p1521, p1530, p1531, p1570, p1580, p1574, p1750, p1759, p1802, p1803, p2140, p2142, p2148, p2150, p2161, p2162, p2163, p2164, p2170, p2175, p2177, p2194, p2390, p2392, p2393</p>

**Note**

p0340 = 1 contains the calculations of p0340 = 2, 3, 4, 5.  
p0340 = 2 calculates the motor parameters (p0350 ... p0360).  
p0340 = 3 contains the calculations of p0340 = 4, 5.  
p0340 = 4 only calculates the controller parameters.  
p0340 = 5 only calculates the controller limits.  
When quick commissioning is exited using p3900 > 0, p0340 is automatically set to 1.  
At the end of the calculations, p0340 is automatically set to 0.

p0341[0...n]	Motor moment of inertia / Mot M_mom of inert
<b>Access level:</b> 3	<b>Calculated:</b> CALC_MOD_ALL
<b>Can be changed:</b> T, U	<b>Scaling:</b> -
<b>Unit group:</b> 25_1	<b>Unit selection:</b> p0100
<b>Min:</b> 0.000000 [kgm <sup>2</sup> ]	<b>Max:</b> 100000.000000 [kgm <sup>2</sup> ]
<b>Description:</b> Sets the motor moment of inertia (without load).	<b>Dynamic index:</b> MDS, p0130
<b>Dependency:</b> IEC drives (p0100 = 0): unit kg m <sup>2</sup> NEMA drives (p0100 = 1): unit lb ft <sup>2</sup> The parameter value is included, together with p0342, in the rated starting time of the motor. See also: p0342, r0345	<b>Function diagram:</b> 6020, 6030, 6031, 6822
	<b>Factory setting:</b> 0.000000 [kgm <sup>2</sup> ]

NOTICE
<p>When selecting a catalog motor (p0301), this parameter is automatically pre-assigned and is write protected. Information in p0300 should be carefully observed when removing write protection.</p>

**Note**

The product of p0341 \* p0342 is used when the speed controller (p0340 = 4) is calculated automatically.

<b>p0342[0...n]</b>	<b>Ratio between the total and motor moment of inertia / Mot MomInert Ratio</b>		
	<b>Access level:</b> 3	<b>Calculated:</b> CALC_MOD_ALL	<b>Data type:</b> FloatingPoint32
	<b>Can be changed:</b> T, U	<b>Scaling:</b> -	<b>Dynamic index:</b> MDS, p0130
	<b>Unit group:</b> -	<b>Unit selection:</b> -	<b>Function diagram:</b> 6020, 6030, 6031, 6822
	<b>Min:</b> 1.000	<b>Max:</b> 10000.000	<b>Factory setting:</b> 1.000
<b>Description:</b>	Sets the ratio between the total moment of inertia/mass (load + motor) and the intrinsic motor moment of inertia/mass (no load).		
<b>Dependency:</b>	This means that together with p0341, the rated starting (accelerating time) of the motor is calculated for a vector drive. See also: p0341, r0345		
	<b>Note</b> The product of p0341 * p0342 is used when the speed controller (p0340 = 4) is calculated automatically.		
<b>p0344[0...n]</b>	<b>Motor weight (for the thermal motor model) / Mot weight th mod</b>		
	<b>Access level:</b> 3	<b>Calculated:</b> CALC_MOD_ALL	<b>Data type:</b> FloatingPoint32
	<b>Can be changed:</b> T	<b>Scaling:</b> -	<b>Dynamic index:</b> MDS, p0130
	<b>Unit group:</b> 27_1	<b>Unit selection:</b> p0100	<b>Function diagram:</b> -
	<b>Min:</b> 0.0 [kg]	<b>Max:</b> 50000.0 [kg]	<b>Factory setting:</b> 0.0 [kg]
<b>Description:</b>	Sets the motor weight.		
<b>Dependency:</b>	IEC drives (p0100 = 0): unit kg NEMA drives (p0100 = 1): unit lb		
	<b>NOTICE</b> When selecting a catalog motor (p0301), this parameter is automatically pre-assigned and is write protected. Information in p0300 should be carefully observed when removing write protection.		
	<b>Note</b> The parameter influences the thermal 3 mass model of the induction motor. The parameter is not used for synchronous motors (p0300 = 2xx).		
<b>r0345[0...n]</b>	<b>Nominal motor starting time / Mot t_start_rated</b>		
	<b>Access level:</b> 3	<b>Calculated:</b> -	<b>Data type:</b> FloatingPoint32
	<b>Can be changed:</b> -	<b>Scaling:</b> -	<b>Dynamic index:</b> MDS, p0130
	<b>Unit group:</b> -	<b>Unit selection:</b> -	<b>Function diagram:</b> -
	<b>Min:</b> - [s]	<b>Max:</b> - [s]	<b>Factory setting:</b> - [s]
<b>Description:</b>	Displays the rated motor starting time. This time corresponds to the time from standstill up to reaching the motor rated speed and the acceleration with motor rated torque (r0333).		
<b>Dependency:</b>	See also: r0313, r0333, p0341, p0342		
<b>p0346[0...n]</b>	<b>Motor excitation build-up time / Mot t_excitation</b>		
	<b>Access level:</b> 3	<b>Calculated:</b> CALC_MOD_REG	<b>Data type:</b> FloatingPoint32
	<b>Can be changed:</b> T, U	<b>Scaling:</b> -	<b>Dynamic index:</b> MDS, p0130
	<b>Unit group:</b> -	<b>Unit selection:</b> -	<b>Function diagram:</b> -
	<b>Min:</b> 0.000 [s]	<b>Max:</b> 20.000 [s]	<b>Factory setting:</b> 0.000 [s]

<b>Description:</b>	<p>Sets the excitation build-up time of the motor.</p> <p>This involves the delay time between enabling the pulses and enabling the ramp-function generator. The induction motor is magnetized during this time.</p>
<p><b>▲ CAUTION</b></p> <p>If there is insufficient magnetization under load or if the acceleration rate is too high, then an induction motor can stall (refer to the note).</p>	
<p><b>Note</b></p> <p>The parameter is calculated using <math>p0340 = 1, 3</math>.</p> <p>For induction motors, the result depends on the rotor time constant (r0384). If this time is excessively reduced, this can result in an inadequate magnetizing of the induction motor. This is the case if the current limit is reached while building up magnetizing. For induction motors, the parameter cannot be set to 0 s (internal limit: <math>0.1 * r0384</math>).</p> <p>For permanent-magnet synchronous motors and vector control, the value depends on the stator time constant (r0386). Here, it defines the time to establish the current for encoderless operation immediately after the pulses have been enabled.</p>	

<b>p0347[0...n]</b>	<b>Motor de-excitation time / Mot t_de-excitat</b>		
	<b>Access level:</b> 3	<b>Calculated:</b> CALC_MOD_REG	<b>Data type:</b> FloatingPoint32
	<b>Can be changed:</b> T, U	<b>Scaling:</b> -	<b>Dynamic index:</b> MDS, p0130
	<b>Unit group:</b> -	<b>Unit selection:</b> -	<b>Function diagram:</b> -
	<b>Min:</b> 0.000 [s]	<b>Max:</b> 20.000 [s]	<b>Factory setting:</b> 0.000 [s]
<b>Description:</b>	<p>Sets the de-magnetizing time (for induction motors) after the inverter pulses have been canceled.</p> <p>The inverter pulses cannot be switched in (enabled) within this delay time.</p>		
<p><b>Note</b></p> <p>The parameter is calculated using <math>p0340 = 1, 3</math>.</p> <p>For induction motors, the result depends on the rotor time constant (r0384).</p> <p>if this time is shortened too much, then this can result in an inadequate de-magnetizing of the induction motor and in an overcurrent condition when the pulses are subsequently enabled (only when the flying restart function is activated and the motor is rotating).</p>			

<b>p0350[0...n]</b>	<b>Motor stator resistance cold / Mot R_stator cold</b>		
	<b>Access level:</b> 3	<b>Calculated:</b> CALC_MOD_EQU	<b>Data type:</b> FloatingPoint32
	<b>Can be changed:</b> T, U	<b>Scaling:</b> -	<b>Dynamic index:</b> MDS, p0130
	<b>Unit group:</b> -	<b>Unit selection:</b> -	<b>Function diagram:</b> -
	<b>Min:</b> 0.00000 [ohm]	<b>Max:</b> 2000.00000 [ohm]	<b>Factory setting:</b> 0.00000 [ohm]
<b>Description:</b>	<p>Sets the stator resistance of the motor at ambient temperature p0625 (phase value).</p>		
<b>Dependency:</b>	<p>See also: p0625</p>		
<p><b>NOTICE</b></p> <p>When selecting a catalog motor (p0301), this parameter is automatically pre-assigned and is write protected. Information in p0300 should be carefully observed when removing write protection.</p>			
<p><b>Note</b></p> <p>The motor identification routine determines the stator resistance from the total stator resistance minus the cable resistance (p0352).</p>			

<b>p0352[0...n]</b>	<b>Cable resistance / R<sub>cable</sub></b>		
<b>Access level:</b> 3	<b>Calculated:</b> -	<b>Data type:</b> FloatingPoint32	
<b>Can be changed:</b> T, U	<b>Scaling:</b> -	<b>Dynamic index:</b> MDS, p0130	
<b>Unit group:</b> -	<b>Unit selection:</b> -	<b>Function diagram:</b> -	
<b>Min:</b> 0.00000 [ohm]	<b>Max:</b> 120.00000 [ohm]	<b>Factory setting:</b> 0.00000 [ohm]	
<b>Description:</b>	Resistance of the power cable between the power unit and motor.		

**⚠ CAUTION**

The cable resistance should be entered prior to motor data identification. If it is used subsequently, the difference by which p0352 was changed must be subtracted from the stator resistance p0350 or motor data identification must be repeated.

**Note**

The parameter influences the temperature adaptation of the stator resistance.

The motor identification sets the cable resistance to 20% of the measured total resistance if p0352 is zero at the time that the measurement is made. If p0352 is not zero, then the value is subtracted from the measured total stator resistance to calculate stator resistance p0350. In this case, p0350 is a minimum of 10% of the measured value.

The cable resistance is reset when quick commissioning is exited with p3900 > 0.

<b>p0352[0...n]</b>	<b>Cable resistance / R<sub>cable</sub></b>		
CUG120X_PN (PM330)	<b>Access level:</b> 3	<b>Calculated:</b> -	<b>Data type:</b> FloatingPoint32
	<b>Can be changed:</b> T, U	<b>Scaling:</b> -	<b>Dynamic index:</b> MDS, p0130
	<b>Unit group:</b> -	<b>Unit selection:</b> -	<b>Function diagram:</b> -
	<b>Min:</b> 0.00000 [ohm]	<b>Max:</b> 120.00000 [ohm]	<b>Factory setting:</b> 0.00000 [ohm]
<b>Description:</b>	Resistance of the power cable between the power unit and motor.		

**⚠ CAUTION**

The cable resistance should be entered prior to motor data identification. If it is used subsequently, the difference by which p0352 was changed must be subtracted from the stator resistance p0350 or motor data identification must be repeated.

The difference with which p0352 was manually changed, must also be subtracted from reference parameter p0629 of the R<sub>s</sub> measurement.

**Note**

The parameter influences the temperature adaptation of the stator resistance.

The motor identification sets the cable resistance to 20% of the measured total resistance if p0352 is zero at the time that the measurement is made. If p0352 is not zero, then the value is subtracted from the measured total stator resistance to calculate stator resistance p0350. In this case, p0350 is a minimum of 10% of the measured value.

The cable resistance is reset when quick commissioning is exited with p3900 > 0.

<b>p0354[0...n]</b>	<b>Motor rotor resistance cold / Mot R<sub>r</sub> cold</b>		
	<b>Access level:</b> 3	<b>Calculated:</b> CALC_MOD_EQU	<b>Data type:</b> FloatingPoint32
	<b>Can be changed:</b> T, U	<b>Scaling:</b> -	<b>Dynamic index:</b> MDS, p0130
	<b>Unit group:</b> -	<b>Unit selection:</b> -	<b>Function diagram:</b> 6727
	<b>Min:</b> 0.00000 [ohm]	<b>Max:</b> 300.00000 [ohm]	<b>Factory setting:</b> 0.00000 [ohm]
<b>Description:</b>	Sets the rotor/secondary section resistance of the motor at the ambient temperature p0625. This parameter value is automatically calculated using the motor model (p0340 = 1, 2) or using the motor data identification routine (p1910).		
<b>Dependency:</b>	See also: p0625		

<b>NOTICE</b>
When selecting a catalog motor (p0301), this parameter is automatically pre-assigned and is write protected. Information in p0300 should be carefully observed when removing write protection.

**Note**

The parameter is not used for synchronous motors (p0300 = 2).

<b>p0356[0...n]</b>	<b>Motor stator leakage inductance / Mot L_stator leak.</b>												
	<table> <tr> <td><b>Access level:</b> 3</td> <td><b>Calculated:</b> CALC_MOD_EQU</td> <td><b>Data type:</b> FloatingPoint32</td> </tr> <tr> <td><b>Can be changed:</b> T, U</td> <td><b>Scaling:</b> -</td> <td><b>Dynamic index:</b> MDS, p0130</td> </tr> <tr> <td><b>Unit group:</b> -</td> <td><b>Unit selection:</b> -</td> <td><b>Function diagram:</b> -</td> </tr> <tr> <td><b>Min:</b> 0.00000 [mH]</td> <td><b>Max:</b> 1000.00000 [mH]</td> <td><b>Factory setting:</b> 0.00000 [mH]</td> </tr> </table>	<b>Access level:</b> 3	<b>Calculated:</b> CALC_MOD_EQU	<b>Data type:</b> FloatingPoint32	<b>Can be changed:</b> T, U	<b>Scaling:</b> -	<b>Dynamic index:</b> MDS, p0130	<b>Unit group:</b> -	<b>Unit selection:</b> -	<b>Function diagram:</b> -	<b>Min:</b> 0.00000 [mH]	<b>Max:</b> 1000.00000 [mH]	<b>Factory setting:</b> 0.00000 [mH]
<b>Access level:</b> 3	<b>Calculated:</b> CALC_MOD_EQU	<b>Data type:</b> FloatingPoint32											
<b>Can be changed:</b> T, U	<b>Scaling:</b> -	<b>Dynamic index:</b> MDS, p0130											
<b>Unit group:</b> -	<b>Unit selection:</b> -	<b>Function diagram:</b> -											
<b>Min:</b> 0.00000 [mH]	<b>Max:</b> 1000.00000 [mH]	<b>Factory setting:</b> 0.00000 [mH]											
<b>Description:</b>	<p>Induction machine: sets the stator leakage inductance of the motor.</p> <p>Synchronous motor: Sets the stator quadrature axis inductance of the motor.</p> <p>This parameter value is automatically calculated using the motor model (p0340 = 1, 2) or using the motor identification routine (p1910).</p>												
	<table border="1"> <tr> <td><b>NOTICE</b></td> </tr> <tr> <td>When selecting a catalog motor (p0301), this parameter is automatically pre-assigned and is write protected. Information in p0300 should be carefully observed when removing write protection.</td> </tr> </table>	<b>NOTICE</b>	When selecting a catalog motor (p0301), this parameter is automatically pre-assigned and is write protected. Information in p0300 should be carefully observed when removing write protection.										
<b>NOTICE</b>													
When selecting a catalog motor (p0301), this parameter is automatically pre-assigned and is write protected. Information in p0300 should be carefully observed when removing write protection.													
	<p><b>Note</b></p> <p>If the stator leakage inductance (p0356) for induction motors is changed outside the commissioning phase (p0010 &gt; 0), the magnetizing inductance (p0360) is automatically adapted to the new EMF (r0337). You are then advised to repeat the measurement for the saturation characteristic (p1960).</p> <p>For permanent-magnet synchronous motors (p0300 = 2), this is the non-saturated value and is, therefore, ideal for a low current.</p> <p>For a controlled reluctance motor (p0300 = 6), this is the direct axis stator inductance at the rated operating point.</p>												

<b>p0357[0...n]</b>	<b>Motor stator inductance d axis / Mot L_stator d</b>												
	<table> <tr> <td><b>Access level:</b> 3</td> <td><b>Calculated:</b> CALC_MOD_EQU</td> <td><b>Data type:</b> FloatingPoint32</td> </tr> <tr> <td><b>Can be changed:</b> T, U</td> <td><b>Scaling:</b> -</td> <td><b>Dynamic index:</b> MDS, p0130</td> </tr> <tr> <td><b>Unit group:</b> -</td> <td><b>Unit selection:</b> -</td> <td><b>Function diagram:</b> -</td> </tr> <tr> <td><b>Min:</b> 0.00000 [mH]</td> <td><b>Max:</b> 1000.00000 [mH]</td> <td><b>Factory setting:</b> 0.00000 [mH]</td> </tr> </table>	<b>Access level:</b> 3	<b>Calculated:</b> CALC_MOD_EQU	<b>Data type:</b> FloatingPoint32	<b>Can be changed:</b> T, U	<b>Scaling:</b> -	<b>Dynamic index:</b> MDS, p0130	<b>Unit group:</b> -	<b>Unit selection:</b> -	<b>Function diagram:</b> -	<b>Min:</b> 0.00000 [mH]	<b>Max:</b> 1000.00000 [mH]	<b>Factory setting:</b> 0.00000 [mH]
<b>Access level:</b> 3	<b>Calculated:</b> CALC_MOD_EQU	<b>Data type:</b> FloatingPoint32											
<b>Can be changed:</b> T, U	<b>Scaling:</b> -	<b>Dynamic index:</b> MDS, p0130											
<b>Unit group:</b> -	<b>Unit selection:</b> -	<b>Function diagram:</b> -											
<b>Min:</b> 0.00000 [mH]	<b>Max:</b> 1000.00000 [mH]	<b>Factory setting:</b> 0.00000 [mH]											
<b>Description:</b>	<p>Sets the stator direct-axis inductance of the synchronous motor.</p> <p>This parameter value is automatically calculated using the motor model (p0340 = 1, 2) or using the motor identification routine (p1910).</p>												
	<p><b>Note</b></p> <p>For permanent-magnet synchronous motors (p0300 = 2), this is the non-saturated value and is ideal for a low current.</p> <p>For a controlled reluctance motor (p0300 = 6), this is the direct axis stator inductance at the rated operating point.</p>												

<b>p0358[0...n]</b>	<b>Motor rotor leakage inductance / Mot L_rot leak</b>												
	<table> <tr> <td><b>Access level:</b> 3</td> <td><b>Calculated:</b> CALC_MOD_EQU</td> <td><b>Data type:</b> FloatingPoint32</td> </tr> <tr> <td><b>Can be changed:</b> T, U</td> <td><b>Scaling:</b> -</td> <td><b>Dynamic index:</b> MDS, p0130</td> </tr> <tr> <td><b>Unit group:</b> -</td> <td><b>Unit selection:</b> -</td> <td><b>Function diagram:</b> 6727</td> </tr> <tr> <td><b>Min:</b> 0.00000 [mH]</td> <td><b>Max:</b> 1000.00000 [mH]</td> <td><b>Factory setting:</b> 0.00000 [mH]</td> </tr> </table>	<b>Access level:</b> 3	<b>Calculated:</b> CALC_MOD_EQU	<b>Data type:</b> FloatingPoint32	<b>Can be changed:</b> T, U	<b>Scaling:</b> -	<b>Dynamic index:</b> MDS, p0130	<b>Unit group:</b> -	<b>Unit selection:</b> -	<b>Function diagram:</b> 6727	<b>Min:</b> 0.00000 [mH]	<b>Max:</b> 1000.00000 [mH]	<b>Factory setting:</b> 0.00000 [mH]
<b>Access level:</b> 3	<b>Calculated:</b> CALC_MOD_EQU	<b>Data type:</b> FloatingPoint32											
<b>Can be changed:</b> T, U	<b>Scaling:</b> -	<b>Dynamic index:</b> MDS, p0130											
<b>Unit group:</b> -	<b>Unit selection:</b> -	<b>Function diagram:</b> 6727											
<b>Min:</b> 0.00000 [mH]	<b>Max:</b> 1000.00000 [mH]	<b>Factory setting:</b> 0.00000 [mH]											
<b>Description:</b>	<p>Sets the rotor/secondary section leakage inductance of the motor.</p> <p>The value is automatically calculated using the motor model (p0340 = 1, 2) or using the motor identification routine (p1910).</p>												

7.3 Parameter list

<b>NOTICE</b>
When selecting a catalog motor (p0301), this parameter is automatically pre-assigned and is write protected. Information in p0300 should be carefully observed when removing write protection.

**Note**  
 If the rotor leakage inductance (p0358) for induction motors is changed outside the commissioning phase (p0010 > 0), then the magnetizing inductance (p0360) is automatically adapted to the new EMF (r0337). You are then advised to repeat the measurement for the saturation characteristic (p1960).

---

**p0360[0...n]      Motor magnetizing inductance / Mot Lh**

<b>Access level:</b> 3	<b>Calculated:</b> CALC_MOD_EQU	<b>Data type:</b> FloatingPoint32
<b>Can be changed:</b> T, U	<b>Scaling:</b> -	<b>Dynamic index:</b> MDS, p0130
<b>Unit group:</b> -	<b>Unit selection:</b> -	<b>Function diagram:</b> 6727
<b>Min:</b> 0.00000 [mH]	<b>Max:</b> 10000.00000 [mH]	<b>Factory setting:</b> 0.00000 [mH]

**Description:** Sets the magnetizing inductance of the motor.  
 This parameter value is automatically calculated using the motor model (p0340 = 1, 2) or using the motor identification routine (p1910).

<b>NOTICE</b>
When selecting a catalog motor (p0301), this parameter is automatically pre-assigned and is write protected. Information in p0300 should be carefully observed when removing write protection.

**Note**  
 The parameter is not used for synchronous motors (p0300 = 2).

---

**r0384[0...n]      Motor rotor time constant / damping time constant d axis / Mot T\_rotor/T\_Dd**

<b>Access level:</b> 3	<b>Calculated:</b> -	<b>Data type:</b> FloatingPoint32
<b>Can be changed:</b> -	<b>Scaling:</b> -	<b>Dynamic index:</b> MDS, p0130
<b>Unit group:</b> -	<b>Unit selection:</b> -	<b>Function diagram:</b> 6722, 6837
<b>Min:</b> - [ms]	<b>Max:</b> - [ms]	<b>Factory setting:</b> - [ms]

**Description:** Displays the rotor time constant.

**Note**  
 The parameter is not used for synchronous motors.  
 The value is calculated from the total of the inductances on the rotor side (p0358, p0360) divided by the rotor resistance (p0354). The temperature adaptation of the rotor resistance for induction motors is not taken into account.

---

**r0394[0...n]      Rated motor power / Mot P Rated**

<b>Access level:</b> 3	<b>Calculated:</b> -	<b>Data type:</b> FloatingPoint32
<b>Can be changed:</b> -	<b>Scaling:</b> -	<b>Dynamic index:</b> MDS, p0130
<b>Unit group:</b> 14_6	<b>Unit selection:</b> p0100	<b>Function diagram:</b> -
<b>Min:</b> - [kW]	<b>Max:</b> - [kW]	<b>Factory setting:</b> - [kW]

**Description:** Displays the rated motor power.

**Note**  
 The parameter displays p0307. For p0307 = 0, r0394 is calculated from p0304 and p0305 (only for induction motors). Depending on the actual motor type, deviations can occur from the actual rated motor power.

<b>r0395[0...n]</b>	<b>Actual stator resistance / R_stator act</b>		
	<b>Access level:</b> 3	<b>Calculated:</b> -	<b>Data type:</b> FloatingPoint32
	<b>Can be changed:</b> -	<b>Scaling:</b> -	<b>Dynamic index:</b> MDS, p0130
	<b>Unit group:</b> -	<b>Unit selection:</b> -	<b>Function diagram:</b> -
	<b>Min:</b> - [ohm]	<b>Max:</b> - [ohm]	<b>Factory setting:</b> - [ohm]
<b>Description:</b>	Displays the actual stator resistance (phase value). The parameter value also contains the temperature-independent cable resistance.		
<b>Dependency:</b>	In the case of induction motors the parameter is also affected by the motor temperature model. See also: p0350, p0352		
	<b>Note</b> In each case, only the stator resistance of the active Motor Data Set is included with the stator temperature of the thermal motor model.		
<b>r0396[0...n]</b>	<b>Actual rotor resistance / R_rotor act</b>		
	<b>Access level:</b> 3	<b>Calculated:</b> -	<b>Data type:</b> FloatingPoint32
	<b>Can be changed:</b> -	<b>Scaling:</b> -	<b>Dynamic index:</b> MDS, p0130
	<b>Unit group:</b> -	<b>Unit selection:</b> -	<b>Function diagram:</b> -
	<b>Min:</b> - [ohm]	<b>Max:</b> - [ohm]	<b>Factory setting:</b> - [ohm]
<b>Description:</b>	Displays the actual rotor resistance (phase value). The parameter is affected by the motor temperature model.		
<b>Dependency:</b>	See also: p0354		
	<b>Note</b> In each case, only the rotor resistance of the active Motor Data Set is included with the rotor temperature of the thermal motor model. This parameter is not used for synchronous motors (p0300 = 2xx).		
<b>p0500</b>	<b>Technology application / Tec application</b>		
	<b>Access level:</b> 2	<b>Calculated:</b> -	<b>Data type:</b> Integer16
	<b>Can be changed:</b> C2(1), T	<b>Scaling:</b> -	<b>Dynamic index:</b> -
	<b>Unit group:</b> -	<b>Unit selection:</b> -	<b>Function diagram:</b> -
	<b>Min:</b> 0	<b>Max:</b> 5	<b>Factory setting:</b> 0
<b>Description:</b>	Sets the technology application. The parameter influences the calculation of open-loop and closed-loop control parameters that is e.g. initiated using p0340 = 5.		
<b>Value:</b>	0: Standard drive 1: Pumps and fans 2: Sensorless closed-loop control down to f = 0 (passive loads) 3: Pumps and fans, efficiency optimization 5: Starting with a high break loose torque		
<b>Dependency:</b>	For p0096 = 1, 2 (Standard, Dynamic Drive Control) p0500 cannot be changed.		
	<b>NOTICE</b> If the technological application is set to p0500 = 0 ... 3 during commissioning (p0010 = 1, 5, 30), the operating mode (p1300) is pre-set accordingly.		

7.3 Parameter list

**Note**

The calculation of parameters dependent on the technology application can be called up as follows:

- when exiting quick commissioning using p3900 > 0
- when writing p0340 = 1, 3, 5

For p0500 = 0 and when the calculation is initiated, the following parameters are set:

- p1574 = 10 V
- p1750.2 = 0
- p1802 = 4 (SVM/FLB without overcontrol) (PM240: p1802 = 0, PM260: p1802 = 2)
- p1803 = 106 % (PM260: p1803 = 103 %)

For p0500 = 1 and when the calculation is initiated, the following parameters are set:

- p1574 = 2 V
- p1750.2 = 0
- p1802 = 4 (SVM/FLB without overcontrol) (PM240: p1802 = 0)
- p1803 = 106 % (PM260: p1803 = 103 %)

For p0500 = 2 and when the calculation is initiated, the following parameters are set:

- p1574 = 2 V (separately excited synchronous motor: 4 V)
- p1750.2 = 1
- p1802 = 4 (SVM/FLB without overcontrol) (PM240: p1802 = 0)
- p1803 = 106 % (PM260: p1803 = 103 %)

For p0500 = 3 and when the calculation is initiated, the following parameters are set:

- p1574 = 2 V
- p1750.2 = 1
- p1802 = 4 (SVM/FLB without overcontrol) (PM240: p1802 = 0)
- p1803 = 106 % (PM260: p1803 = 103 %)

For p0500 = 5:

- p1574, p1750.2, p1802, p1803 same as for p0500 = 0
- p1610 = 80 %, p1611 = 80 % (average up to higher starting torque)
- p1310 = 80 %, p1311 = 30 %

In all cases, the DC component compensation is activated (p3855 = 7).

For p1750:

The setting of p1750 is only relevant for induction motors.

p1750.2 = 1: Encoderless control of the induction motor is effective down to zero frequency.

This operating mode is possible for passive loads. These include applications where the load does not generate regenerative torque when breaking away and the motor comes to a standstill (zero speed) itself when the pulses are inhibited.

For p1802 / p1803:

p1802 and p1803 are only changed, in all cases, if a sine-wave output filter (p0230 = 3, 4) has not been selected.

**p0500**

CUG120X\_PN  
(PM330)

**Technology application / Tec application**

**Access level:** 2

**Calculated:** -

**Data type:** Integer16

**Can be changed:** C2(1), T

**Scaling:** -

**Dynamic index:** -

**Unit group:** -

**Unit selection:** -

**Function diagram:** -

**Min:**

**Max:**

**Factory setting:**

1

3

3

**Description:**

Sets the technology application.

The parameter influences the calculation of open-loop and closed-loop control parameters that is e.g. initiated using p0340 = 5.

**Value:**

1: Pumps and fans

3: Pumps and fans, efficiency optimization

**Dependency:**

For p0096 = 2 (Dynamic Drive Control) p0500 cannot be changed.

**NOTICE**

If the technological application is set to p0500 = 0 ... 3 during commissioning (p0010 = 1, 5, 30), the operating mode (p1300) is pre-set accordingly.



**Note**

The calculation of parameters dependent on the technology application can be called up as follows:

- when exiting quick commissioning using p3900 > 0
- when writing p0340 = 1, 3, 5

For p0500 = 1 and when the calculation is initiated, the following parameters are set:

- p1570 = 100 %
- p1580 = 0 % (no efficiency optimization)
- p1574 = 2 V
- p1750.2 = 0
- p1802 = 9 or 19 (optimized pulse pattern for p0300 = 14)
- p1803 = 106 %

For p0500 = 3 and when the calculation is initiated, the following parameters are set:

- p1570 = 103 % (flux boost for full load)
- p1580 = 100 % (efficiency optimization)
- p1574 = 2 V
- p1750.2 = 1: Encoderless control of the induction motor is effective down to zero frequency.
- p1802 = 9 or 19 (optimized pulse pattern for p0300 = 14)
- p1803 = 106 %

**p0501****Technological application (Standard Drive Control) / Techn appl SDC**

**Access level:** 2

**Calculated:** -

**Data type:** Integer16

**Can be changed:** C2(1), T

**Scaling:** -

**Dynamic index:** -

**Unit group:** -

**Unit selection:** -

**Function diagram:** -

**Min:**

**Max:**

**Factory setting:**

0

1

0

**Description:**

Sets the technology application.

The parameter influences the calculation of open-loop and closed-loop control parameters that is e.g. initiated using p0340 = 5.

**Value:**

0: Constant load (linear characteristic)

1: Speed-dependent load (parabolic characteristic)

**Dependency:**

See also: p1300

**NOTICE**

If the technological application is set to p0501 = 0, 1 during commissioning (p0010 = 1, 5, 30), the operating mode (p1300) is pre-set accordingly.

**Note**

The calculation of parameters dependent on the technology application can be called up as follows:

- when exiting quick commissioning using p3900 > 0
- when writing p0340 = 1, 3, 5

For p0501 = 0, 1 and when the calculation is initiated, the following parameters are set:

- p1802 = 0
- p1803 = 106 %
- p3855.0 = 1 (DC quantity control on)

For p1802 / p1803:

These parameters are only changed, in all cases, if a sine-wave output filter (p0230 = 3, 4) has not been selected.

**p0502****Technological application (Dynamic Drive Control) / Techn appl DDC**

**Access level:** 2

**Calculated:** -

**Data type:** Integer16

**Can be changed:** C2(1), T

**Scaling:** -

**Dynamic index:** -

**Unit group:** -

**Unit selection:** -

**Function diagram:** -

**Min:**

**Max:**

**Factory setting:**

0

5

0

7.3 Parameter list

**Description:** Sets the technology application for dynamic applications (p0096 = 2).  
The parameter influences the calculation of open-loop and closed-loop control parameters that is e.g. initiated using p0340 or p3900.

**Value:** 0: Standard drive (e.g. pumps, fans)  
1: Dynamic starting or reversing  
5: Heavy-duty starting (e.g. extruders, compressors)

**Dependency:** The calculation of parameters dependent on the technology application can be called up as follows:  
- when exiting quick commissioning using p3900 > 0  
- when writing p0340 = 1, 3 or 5  
See also: p1610, p1750

**Note**

When entering p0502 and initiating the calculation, the following parameters are set:  
p0502 = 0:  
- p1750.0/1/7 = 1 (start and reverse in open-loop control with rugged switchover limits)  
- p1610 = 50 %, p1611 = 30 % (low up to average starting torque)  
p0502 = 1:  
- p1750.0/1/7 = 0 (start and reverse in closed-loop speed control with shorter acceleration times)  
- p1610 = 50 %, p1611 = 30 % (only effective, if the drive is switched-on with a speed setpoint of zero)  
p0502 = 5:  
- p1750.0/1/7 = 1 (start and reverse in open-loop control with rugged switchover limits)  
- p1610 = 80 %, p1611 = 80 % (average up to higher starting torque)  
p1750.6 = 1 is always set, p1574 (voltage reserve) is preassigned, depending on p0205 (power unit application).

**p0502**

CUG120X\_PN  
(PM330)

**Technological application (Dynamic Drive Control) / Techn appl DDC**

<b>Access level:</b> 2	<b>Calculated:</b> -	<b>Data type:</b> Integer16
<b>Can be changed:</b> C2(1), T	<b>Scaling:</b> -	<b>Dynamic index:</b> -
<b>Unit group:</b> -	<b>Unit selection:</b> -	<b>Function diagram:</b> -
<b>Min:</b> 3	<b>Max:</b> 3	<b>Factory setting:</b> 3

**Description:** Sets the technology application for dynamic applications (p0096 = 2).  
The parameter influences the calculation of open-loop and closed-loop control parameters that is e.g. initiated using p0340 or p3900.

**Value:** 3: Pumps and fans, efficiency optimization

**Dependency:** The calculation of parameters dependent on the technology application can be called up as follows:  
- when exiting quick commissioning using p3900 > 0  
- when writing p0340 = 1, 3 or 5  
See also: p1610, p1750

**Note**

The calculation of parameters dependent on the technology application can be called up as follows:  
- when exiting quick commissioning using p3900 > 0  
- when writing p0340 = 1, 3, 5  
For p0500 = 3 and when the calculation is initiated, the following parameters are set:  
- p1570 = 103 % (flux boost for full load)  
- p1580 = 100 % (efficiency optimization)  
- p1574 = 2 V  
- p1750.2 = 1: Encoderless control of the induction motor is effective down to zero frequency.  
- p1802 = 9 or 19 (optimized pulse pattern for p0300 = 14)  
- p1803 = 106 %

<b>p0505</b>	<b>Selecting the system of units / Unit sys select</b>		
	<b>Access level:</b> 1	<b>Calculated:</b> -	<b>Data type:</b> Integer16
	<b>Can be changed:</b> C2(5)	<b>Scaling:</b> -	<b>Dynamic index:</b> -
	<b>Unit group:</b> -	<b>Unit selection:</b> -	<b>Function diagram:</b> -
	<b>Min:</b> 1	<b>Max:</b> 4	<b>Factory setting:</b> 1
<b>Description:</b>	Sets the actual system of units.		
<b>Value:</b>	1: SI system of units 2: System of units referred/SI 3: US system of units 4: System of units referred/US		
<b>Dependency:</b>	The parameter can only be changed in an offline project using the commissioning software.		
	<p><b>⚠ CAUTION</b></p> <p>If a per unit representation is selected and if the reference parameters (e.g. p2000) are subsequently changed, then the physical significance of several control parameters is also adapted at the same time. As a consequence, the control behavior can change (see p1744, p1752, p1755).</p>		
	<p><b>Note</b></p> <p>Reference parameter for the unit system % are, for example, p2000 ... p2004. Depending on what has been selected, these are displayed using either SI or US units.</p>		
<b>p0514[0...9]</b>	<b>Scaling-specific reference values / Scal spec ref val</b>		
	<b>Access level:</b> 3	<b>Calculated:</b> CALC_MOD_ALL	<b>Data type:</b> FloatingPoint32
	<b>Can be changed:</b> T	<b>Scaling:</b> -	<b>Dynamic index:</b> -
	<b>Unit group:</b> -	<b>Unit selection:</b> -	<b>Function diagram:</b> -
	<b>Min:</b> 0.000001	<b>Max:</b> 1000000.000000	<b>Factory setting:</b> 1.000000
<b>Description:</b>	<p>Sets the reference values for the specific scaling of BICO parameters.</p> <p>The specific scaling is active when interconnecting with other BICO parameters, and can be used in the following cases:</p> <ol style="list-style-type: none"> <li>1. Parameter with the marking "Scaling: p0514".</li> <li>2. Changing the standard scaling for parameters with the marking "Scaling: p2000" ... "Scaling: p2007".</li> </ol> <p>Relative values refer to the corresponding reference value. The reference value corresponds to 100% or 4000 hex (word) or 4000 0000 hex (double word).</p> <p>To specifically scale BICO parameters, proceed as follows:</p> <ul style="list-style-type: none"> <li>- set the reference value (p0514[0...9]).</li> <li>- set the numbers of the parameters, which should be active for the scaling, corresponding to the index of p0514 (p0515[0...19] ... p0524[0...19]).</li> </ul> <p>For parameters with the marking "Scaling: p0514", which are not entered in p0515[0...19] to p0524[0...19], the reference value 1.0 (factory setting) applies.</p>		
<b>Index:</b>	<p>[0] = Parameters in p0515[0...19]          [1] = Parameters in p0516[0...19]          [2] = Parameters in p0517[0...19]          [3] = Parameters in p0518[0...19]          [4] = Parameters in p0519[0...19]          [5] = Parameters in p0520[0...19]          [6] = Parameters in p0521[0...19]          [7] = Parameters in p0522[0...19]          [8] = Parameters in p0523[0...19]          [9] = Parameters in p0524[0...19]</p>		
<b>Dependency:</b>	See also: p0515, p0516, p0517, p0518, p0519, p0520, p0521, p0522, p0523, p0524		

<b>p0515[0...19]</b>	<b>Scaling specific parameters referred to p0514[0] / Scal spec p514[0]</b>		
	<b>Access level:</b> 3	<b>Calculated:</b> CALC_MOD_ALL	<b>Data type:</b> Unsigned32
	<b>Can be changed:</b> T	<b>Scaling:</b> -	<b>Dynamic index:</b> -
	<b>Unit group:</b> -	<b>Unit selection:</b> -	<b>Function diagram:</b> -
	<b>Min:</b> 0	<b>Max:</b> 4294967295	<b>Factory setting:</b> 0
<b>Description:</b>	Sets the parameters with reference value in p0514[0] for the specific scaling. p0515[0]: parameter number p0515[1]: parameter number p0515[2]: parameter number ... p0515[19]: parameter number		
<b>Dependency:</b>	See also: p0514		
<b>p0516[0...19]</b>	<b>Scaling specific parameters referred to p0514[1] / Scal spec p514[1]</b>		
	<b>Access level:</b> 3	<b>Calculated:</b> CALC_MOD_ALL	<b>Data type:</b> Unsigned32
	<b>Can be changed:</b> T	<b>Scaling:</b> -	<b>Dynamic index:</b> -
	<b>Unit group:</b> -	<b>Unit selection:</b> -	<b>Function diagram:</b> -
	<b>Min:</b> 0	<b>Max:</b> 4294967295	<b>Factory setting:</b> 0
<b>Description:</b>	Sets the parameters with reference value in p0514[1] for the specific scaling. p0516[0]: parameter number p0516[1]: parameter number p0516[2]: parameter number ... p0516[19]: parameter number		
<b>Dependency:</b>	See also: p0514		
<b>p0517[0...19]</b>	<b>Scaling specific parameters referred to p0514[2] / Scal spec p514[2]</b>		
	<b>Access level:</b> 3	<b>Calculated:</b> CALC_MOD_ALL	<b>Data type:</b> Unsigned32
	<b>Can be changed:</b> T	<b>Scaling:</b> -	<b>Dynamic index:</b> -
	<b>Unit group:</b> -	<b>Unit selection:</b> -	<b>Function diagram:</b> -
	<b>Min:</b> 0	<b>Max:</b> 4294967295	<b>Factory setting:</b> 0
<b>Description:</b>	Sets the parameters with reference value in p0514[2] for the specific scaling. p0517[0]: parameter number p0517[1]: parameter number p0517[2]: parameter number ... p0517[19]: parameter number		
<b>Dependency:</b>	See also: p0514		
<b>p0518[0...19]</b>	<b>Scaling specific parameters referred to p0514[3] / Scal spec p514[3]</b>		
	<b>Access level:</b> 3	<b>Calculated:</b> CALC_MOD_ALL	<b>Data type:</b> Unsigned32
	<b>Can be changed:</b> T	<b>Scaling:</b> -	<b>Dynamic index:</b> -
	<b>Unit group:</b> -	<b>Unit selection:</b> -	<b>Function diagram:</b> -
	<b>Min:</b> 0	<b>Max:</b> 4294967295	<b>Factory setting:</b> 0

**Description:** Sets the parameters with reference value in p0514[3] for the specific scaling.

p0518[0]: parameter number  
 p0518[1]: parameter number  
 p0518[2]: parameter number  
 ...  
 p0518[19]: parameter number

**Dependency:** See also: p0514

#### p0519[0...19] **Scaling specific parameters referred to p0514[4] / Scal spec p514[4]**

<b>Access level:</b> 3	<b>Calculated:</b> CALC_MOD_ALL	<b>Data type:</b> Unsigned32
<b>Can be changed:</b> T	<b>Scaling:</b> -	<b>Dynamic index:</b> -
<b>Unit group:</b> -	<b>Unit selection:</b> -	<b>Function diagram:</b> -
<b>Min:</b> 0	<b>Max:</b> 4294967295	<b>Factory setting:</b> 0

**Description:** Sets the parameters with reference value in p0514[4] for the specific scaling.

p0519[0]: parameter number  
 p0519[1]: parameter number  
 p0519[2]: parameter number  
 ...  
 p0519[19]: parameter number

**Dependency:** See also: p0514

#### p0520[0...19] **Scaling specific parameters referred to p0514[5] / Scal spec p514[5]**

<b>Access level:</b> 3	<b>Calculated:</b> CALC_MOD_ALL	<b>Data type:</b> Unsigned32
<b>Can be changed:</b> T	<b>Scaling:</b> -	<b>Dynamic index:</b> -
<b>Unit group:</b> -	<b>Unit selection:</b> -	<b>Function diagram:</b> -
<b>Min:</b> 0	<b>Max:</b> 4294967295	<b>Factory setting:</b> 0

**Description:** Sets the parameters with reference value in p0514[5] for the specific scaling.

p0520[0]: parameter number  
 p0520[1]: parameter number  
 p0520[2]: parameter number  
 ...  
 p0520[19]: parameter number

**Dependency:** See also: p0514

#### p0521[0...19] **Scaling specific parameters referred to p0514[6] / Scal spec p514[6]**

<b>Access level:</b> 3	<b>Calculated:</b> CALC_MOD_ALL	<b>Data type:</b> Unsigned32
<b>Can be changed:</b> T	<b>Scaling:</b> -	<b>Dynamic index:</b> -
<b>Unit group:</b> -	<b>Unit selection:</b> -	<b>Function diagram:</b> -
<b>Min:</b> 0	<b>Max:</b> 4294967295	<b>Factory setting:</b> 0

**Description:** Sets the parameters with reference value in p0514[6] for the specific scaling.

p0521[0]: parameter number  
 p0521[1]: parameter number  
 p0521[2]: parameter number  
 ...  
 p0521[19]: parameter number

**Dependency:** See also: p0514

<b>p0522[0...19]</b>	<b>Scaling specific parameters referred to p0514[7] / Scal spec p514[7]</b>		
	<b>Access level:</b> 3	<b>Calculated:</b> CALC_MOD_ALL	<b>Data type:</b> Unsigned32
	<b>Can be changed:</b> T	<b>Scaling:</b> -	<b>Dynamic index:</b> -
	<b>Unit group:</b> -	<b>Unit selection:</b> -	<b>Function diagram:</b> -
	<b>Min:</b> 0	<b>Max:</b> 4294967295	<b>Factory setting:</b> 0
<b>Description:</b>	Sets the parameters with reference value in p0514[7] for the specific scaling. p0522[0]: parameter number p0522[1]: parameter number p0522[2]: parameter number ... p0522[19]: parameter number		
<b>Dependency:</b>	See also: p0514		
<b>p0523[0...19]</b>	<b>Scaling specific parameters referred to p0514[8] / Scal spec p514[8]</b>		
	<b>Access level:</b> 3	<b>Calculated:</b> CALC_MOD_ALL	<b>Data type:</b> Unsigned32
	<b>Can be changed:</b> T	<b>Scaling:</b> -	<b>Dynamic index:</b> -
	<b>Unit group:</b> -	<b>Unit selection:</b> -	<b>Function diagram:</b> -
	<b>Min:</b> 0	<b>Max:</b> 4294967295	<b>Factory setting:</b> 0
<b>Description:</b>	Sets the parameters with reference value in p0514[8] for the specific scaling. p0523[0]: parameter number p0523[1]: parameter number p0523[2]: parameter number ... p0523[19]: parameter number		
<b>Dependency:</b>	See also: p0514		
<b>p0524[0...19]</b>	<b>Scaling specific parameters referred to p0514[9] / Scal spec p514[9]</b>		
	<b>Access level:</b> 3	<b>Calculated:</b> CALC_MOD_ALL	<b>Data type:</b> Unsigned32
	<b>Can be changed:</b> T	<b>Scaling:</b> -	<b>Dynamic index:</b> -
	<b>Unit group:</b> -	<b>Unit selection:</b> -	<b>Function diagram:</b> -
	<b>Min:</b> 0	<b>Max:</b> 4294967295	<b>Factory setting:</b> 0
<b>Description:</b>	Sets the parameters with reference value in p0514[9] for the specific scaling. p0524[0]: parameter number p0524[1]: parameter number p0524[2]: parameter number ... p0524[19]: parameter number		
<b>Dependency:</b>	See also: p0514		
<b>p0530[0...n]</b>	<b>Bearing version selection / Bearing vers sel</b>		
	<b>Access level:</b> 3	<b>Calculated:</b> -	<b>Data type:</b> Unsigned16
	<b>Can be changed:</b> C2(1, 3)	<b>Scaling:</b> -	<b>Dynamic index:</b> MDS, p0130
	<b>Unit group:</b> -	<b>Unit selection:</b> -	<b>Function diagram:</b> -
	<b>Min:</b> 0	<b>Max:</b> 104	<b>Factory setting:</b> 0

- Description:** Sets the bearing version.  
Corresponding to the bearing version entered, its code number (p0531) is automatically set.  
0 = No data  
1 = Manual entry  
101 = STANDARD  
102 = PERFORMANCE  
103 = HIGH PERFORMANCE  
104 = ADVANCED LIFETIME
- Dependency:** See also: p0301, p0531, p0532, p1082

<p><b>NOTICE</b></p> <p>For p0530 = 101, 102, 103, 104, the maximum bearing speed (p0532) is write protected. Write protection is withdrawn with p0530 = 1.</p> <p>If p0530 is changed during quick commissioning (p0010 = 1), then the maximum speed p1082, which is also associated with quick commissioning, is pre-assigned appropriately. This is not the case when commissioning the motor (p0010 = 3). The maximum speed of the bearing is factored into the limit for the maximum speed p1082.</p>
--

**Note**  
For a motor with DRIVE-CLiQ, p0530 can only be set to 1.

- 
- p0531[0...n]**      **Bearing code number selection / Bearing codeNo sel**
- |                              |                          |                                  |
|------------------------------|--------------------------|----------------------------------|
| <b>Access level:</b> 3       | <b>Calculated:</b> -     | <b>Data type:</b> Unsigned16     |
| <b>Can be changed:</b> C2(3) | <b>Scaling:</b> -        | <b>Dynamic index:</b> MDS, p0130 |
| <b>Unit group:</b> -         | <b>Unit selection:</b> - | <b>Function diagram:</b> -       |
| <b>Min:</b><br>0             | <b>Max:</b><br>65535     | <b>Factory setting:</b><br>0     |

- Description:** Display and setting the code number of the bearing.  
When setting p0301 and p0530 the code number is automatically pre-assigned and is write protected. The information in p0530 should be observed when removing write protection.
- Dependency:** See also: p0301, p0530, p0532, p1082

<p><b>NOTICE</b></p> <p>If p0531 is changed during quick commissioning (p0010 = 1), then the maximum speed p1082, which is also associated with quick commissioning, is pre-assigned appropriately. This is not the case when commissioning the motor (p0010 = 3). The maximum speed of the bearing is factored into the limit for the maximum speed p1082.</p>
---

**Note**  
p0531 cannot be changed on a motor with DRIVE-CLiQ.

- 
- p0532[0...n]**      **Bearing maximum speed / Bearing n\_max**
- |                                 |                               |                                      |
|---------------------------------|-------------------------------|--------------------------------------|
| <b>Access level:</b> 3          | <b>Calculated:</b> -          | <b>Data type:</b> FloatingPoint32    |
| <b>Can be changed:</b> C2(1, 3) | <b>Scaling:</b> -             | <b>Dynamic index:</b> MDS, p0130     |
| <b>Unit group:</b> -            | <b>Unit selection:</b> -      | <b>Function diagram:</b> -           |
| <b>Min:</b><br>0.0 [rpm]        | <b>Max:</b><br>210000.0 [rpm] | <b>Factory setting:</b><br>0.0 [rpm] |

- Description:** Sets the maximum speed of the bearing.  
The following applies when calculating the maximum speed (p1082):  
- for p0324 = 0 or p0532 = 0, p0322 is used.  
- for p0324 > 0 and p0532 > 0, the minimum value from the two parameters is used.
- Dependency:** See also: p0301, p0322, p0530, p1082

7.3 Parameter list

**NOTICE**

This parameter is pre-assigned in the case of motors from the motor list (p0301) if a bearing version (p0530) is selected.

When selecting a catalog motor, this parameter cannot be changed (write protection). The information in p0530 should be observed when removing write protection.

If p0532 is changed during quick commissioning (p0010 = 1), then the maximum speed p1082, which is also associated with quick commissioning, is pre-assigned appropriately. This is not the case when commissioning the motor (p0010 = 3).

**p0573**

**Inhibit automatic reference value calculation / Inhibit calc**

<b>Access level:</b> 3	<b>Calculated:</b> -	<b>Data type:</b> Integer16
<b>Can be changed:</b> T, U	<b>Scaling:</b> -	<b>Dynamic index:</b> -
<b>Unit group:</b> -	<b>Unit selection:</b> -	<b>Function diagram:</b> -
<b>Min:</b> 0	<b>Max:</b> 1	<b>Factory setting:</b> 0

**Description:** Setting to inhibit the calculation of reference parameters (e.g. p2000) when automatically calculating the motor and closed-loop control parameters (p0340, p3900).

**Value:**  
0: No  
1: Yes

**NOTICE**

The inhibit for the reference value calculation is canceled when new motor parameters (e.g. p0305) are entered and only one drive data set exists (p0180 = 1). This is the case during initial commissioning.

Once the motor and control parameters have been calculated (p0340, p3900), the inhibit for the reference value calculation is automatically re-activated.

**Note**

If value = 0:  
The automatic calculation (p0340, p3900) overwrites the reference parameters.

If value = 1:  
The automatic calculation (p0340, p3900) does not overwrite the reference parameters.

**p0595**

**Technological unit selection / Tech unit select**

<b>Access level:</b> 1	<b>Calculated:</b> -	<b>Data type:</b> Integer16
<b>Can be changed:</b> C2(5)	<b>Scaling:</b> -	<b>Dynamic index:</b> -
<b>Unit group:</b> -	<b>Unit selection:</b> -	<b>Function diagram:</b> -
<b>Min:</b> 1	<b>Max:</b> 48	<b>Factory setting:</b> 1

**Description:** Selects the units for the parameters of the technology controller.  
For p0595 = 1, 2, the reference quantity set in p0596 is not active.

**Value:**

- 1: %
- 2: 1 referred no dimensions
- 3: bar
- 4: °C
- 5: Pa
- 6: ltr/s
- 7: m³/s
- 8: ltr/min
- 9: m³/min
- 10: ltr/h
- 11: m³/h
- 12: kg/s



---

13:	kg/min
14:	kg/h
15:	t/min
16:	t/h
17:	N
18:	kN
19:	Nm
20:	psi
21:	°F
22:	gallon/s
23:	inch <sup>3</sup> /s
24:	gallon/min
25:	inch <sup>3</sup> /min
26:	gallon/h
27:	inch <sup>3</sup> /h
28:	lb/s
29:	lb/min
30:	lb/h
31:	lbf
32:	lbf ft
33:	K
34:	rpm
35:	parts/min
36:	m/s
37:	ft <sup>3</sup> /s
38:	ft <sup>3</sup> /min
39:	BTU/min
40:	BTU/h
41:	mbar
42:	inch wg
43:	ft wg
44:	m wg
45:	% r.h.
46:	g/kg
47:	ppm
48:	kg/cm <sup>2</sup>

**Dependency:** Only the unit of the technology controller parameters are switched over (unit group 9\_1).  
See also: p0596

---

**Note**

When switching over from % into another unit, the following sequence applies:  
- set p0596  
- set p0595 to the required unit

---



---

**p0596**

**Technological unit reference quantity / Tech unit ref qty**

**Access level:** 1

**Can be changed:** T

**Unit group:** -

**Min:**

0.01

**Calculated:** -

**Scaling:** -

**Unit selection:** -

**Max:**

340.28235E36

**Data type:** FloatingPoint32

**Dynamic index:** -

**Function diagram:** -

**Factory setting:**

1.00

7.3 Parameter list

**Description:** Sets the reference quantity for the technological units.  
When changing over using changeover parameter p0595 to absolute units, all of the parameters involved refer to the reference quantity.

**Dependency:** See also: p0595

**NOTICE**  
When changing over from one technological unit into another, or when changing the reference parameter, a changeover is not made.

**p0601[0...n] Motor temperature sensor type / Mot\_temp\_sens type**

<b>Access level:</b> 2	<b>Calculated:</b> -	<b>Data type:</b> Integer16
<b>Can be changed:</b> T, U	<b>Scaling:</b> -	<b>Dynamic index:</b> MDS, p0130
<b>Unit group:</b> -	<b>Unit selection:</b> -	<b>Function diagram:</b> 8016
<b>Min:</b> 0	<b>Max:</b> 6	<b>Factory setting:</b> 0

**Description:** Sets the sensor type for the motor temperature monitoring.

**Value:**

- 0: No sensor
- 1: PTC alarm & timer
- 2: KTY84
- 4: Bimetallic NC contact alarm & timer
- 6: PT1000

**Dependency:** A thermal motor model is calculated corresponding to p0612.

**⚠ CAUTION**  
For p0601 = 2, 6:  
If the motor temperature sensor is not connected but another encoder, then the temperature adaptation of the motor resistances must be switched out (p0620 = 0). Otherwise, in controlled-loop operation, torque errors will occur that will mean that the motor will not be able to be stopped.

**Note**  
For p0601 = 1:  
Tripping resistance = 1650 Ohm. Wire breakage and short-circuit monitoring.

**p0604[0...n] Mot\_temp\_mod 2/sensor alarm threshold / Mod 2/sens A\_thr**

<b>Access level:</b> 2	<b>Calculated:</b> -	<b>Data type:</b> FloatingPoint32
<b>Can be changed:</b> T, U	<b>Scaling:</b> -	<b>Dynamic index:</b> MDS, p0130
<b>Unit group:</b> 21_1	<b>Unit selection:</b> p0505	<b>Function diagram:</b> 8016
<b>Min:</b> 0.0 [°C]	<b>Max:</b> 240.0 [°C]	<b>Factory setting:</b> 130.0 [°C]

**Description:** Sets the alarm threshold for monitoring the motor temperature for motor temperature model 2 or KTY/PT1000. Alarm A07910 is output after the alarm threshold is exceeded.

**Dependency:** See also: p0612  
See also: F07011, A07910

**NOTICE**  
When selecting a catalog motor (p0301), this parameter is automatically pre-assigned and is write protected. Information in p0300 should be carefully observed when removing write protection.

**Note**  
The hysteresis is 2 K.  
When quick commissioning is exited with p3900 > 0, then the parameter is reset if a catalog motor has not been selected (p0300).

<b>p0605[0...n]</b>	<b>Mot_temp_mod 1/2/sensor threshold and temperature value / Mod1/2/sens T_thr</b>		
	<b>Access level:</b> 2	<b>Calculated:</b> -	<b>Data type:</b> FloatingPoint32
	<b>Can be changed:</b> T, U	<b>Scaling:</b> -	<b>Dynamic index:</b> MDS, p0130
	<b>Unit group:</b> 21_1	<b>Unit selection:</b> p0505	<b>Function diagram:</b> 8016, 8017
	<b>Min:</b> 0.0 [°C]	<b>Max:</b> 240.0 [°C]	<b>Factory setting:</b> 145.0 [°C]

<b>Description:</b>	<p>Sets the threshold and temperature value to monitor the motor temperature.</p> <p>Temperature model 1 (I2t, p0612.0 = 1):</p> <p>The following applies for firmware version &lt; 4.7 SP6 or p0612.8 = 0:</p> <ul style="list-style-type: none"> <li>- sets the alarm threshold. If the model temperature (r0034) exceeds the alarm threshold, then alarm A07012 is output.</li> <li>- this value is simultaneously used as rated winding temperature.</li> </ul> <p>The following applies from firmware version 4.7 SP6 and p0612.8 = 1:</p> <ul style="list-style-type: none"> <li>- p5390: when commissioning a catalog motor for the first time, p0605 is copied to p5390.</li> <li>- p5390: p5390 is of significance when evaluating the alarm threshold.</li> <li>- p5390: the stator winding temperature (r0632) is used to initiate the signal.</li> <li>- p0627: when a catalog motor is commissioned for the first time, p0605 -40 °C is copied to p0627.</li> <li>- p0627: p0627 is of significance for the rated temperature.</li> </ul> <p>Motor temperature model 2 (p0612.1 = 1) or measurement:</p> <ul style="list-style-type: none"> <li>- sets the fault threshold. If the temperature (r0035) exceeds the fault threshold, then fault F07011 is output.</li> </ul>
<b>Dependency:</b>	<p>See also: r0034, p0611, p0612</p> <p>See also: F07011, A07012</p>

**NOTICE**

When selecting a catalog motor (p0301), this parameter is automatically pre-assigned and is write protected. Information in p0300 should be carefully observed when removing write protection.

Motor temperature model 1 (I2t):

The following applies for firmware version < 4.7 SP6 or p0612.8 = 0:

p0605 also defines the final temperature of the model for r0034 = 100 %. Therefore, p0605 has no influence on the time up to alarm A07012 being issued. The time is only determined by time constant p0611, the actual current and the reference value p0318. For p0318 = 0, the rated motor current is used as reference value.

**Note**

The hysteresis is 2 K.

When quick commissioning is exited with p3900 > 0, then the parameter is reset if a catalog motor has not been selected (p0300).

<b>p0610[0...n]</b>	<b>Motor overtemperature response / Mot temp response</b>		
	<b>Access level:</b> 2	<b>Calculated:</b> -	<b>Data type:</b> Integer16
	<b>Can be changed:</b> T	<b>Scaling:</b> -	<b>Dynamic index:</b> MDS, p0130
	<b>Unit group:</b> -	<b>Unit selection:</b> -	<b>Function diagram:</b> 8016, 8017, 8018
	<b>Min:</b> 0	<b>Max:</b> 12	<b>Factory setting:</b> 12
<b>Description:</b>	Sets the system response when the motor temperature reaches the alarm threshold.		
<b>Value:</b>	<p>0: No response only alarm no reduction of I_max</p> <p>1: Messages, reduction of I_max</p> <p>2: Messages, no reduction of I_max</p> <p>12: Messages, no reduction of I_max, temperature storage</p>		
<b>Dependency:</b>	<p>See also: p0601, p0604, p0605, p0614, p0615</p> <p>See also: F07011, A07012, A07910</p>		

7.3 Parameter list

**Note**

The I<sub>max</sub> reduction is not executed for PTC (p0601 = 1) or bimetallic NC contact (p0601 = 4).

The I<sub>max</sub> reduction results in a lower output frequency.

If value = 0:

An alarm is output and I<sub>max</sub> is not reduced.

If value = 1:

An alarm is output and a timer is started. A fault is output if the alarm is still active after this timer has expired.

- for KTY/PT1000, the following applies: I<sub>max</sub> is reduced

- for PTC, the following is valid: I<sub>max</sub> is not reduced

If value = 2:

An alarm is output and a timer is started. A fault is output if the alarm is still active after this timer has expired.

If value = 12:

Behavior is always the same as for value 2.

For motor temperature monitoring without temperature sensor, when switching off, the model temperature is saved in a non-volatile fashion. When switching on, the same value (reduced by p0614) is taken into account in the model calculation. As a consequence, the UL508C specification is fulfilled.

**p0611[0...n]**

**I2t motor model thermal time constant / I2t mot\_mod T**

**Access level:** 3

**Calculated:** -

**Data type:** FloatingPoint32

**Can be changed:** C2(1), T, U

**Scaling:** -

**Dynamic index:** MDS, p0130

**Unit group:** -

**Unit selection:** -

**Function diagram:** 8017

**Min:**

**Max:**

**Factory setting:**

0 [s]

20000 [s]

0 [s]

**Description:**

Sets the winding time constant.

The time constant specifies the warm-up time of the cold stator winding when loaded with the motor standstill current (rated motor current, if the motor standstill current is not parameterized) up until a temperature rise of 63 % of the continuously permissible winding temperature has been reached.

**Dependency:**

The parameter is only used for synchronous motors (p0300 = 2xx, 4) and synchronous reluctance motors (p0300 = 6xx).

See also: r0034, p0612, p0615

See also: F07011, A07012, A07910

**NOTICE**

This parameter is automatically pre-set from the motor database for motors from the motor list (p0301). When selecting a catalog motor, this parameter cannot be changed (write protection). Information in p0300 should be carefully observed when removing write protection. When exiting commissioning, p0612 is checked, and where relevant, is pre-assigned to a value that matches the motor power, if a temperature sensor was not parameterized (see p0601).

**Note**

When parameter p0611 is reset to 0, then this switches out the thermal I2t motor model (refer to p0612).

If no temperature sensor is parameterized, then the ambient temperature for the thermal motor model is referred to p0625.

**p0612[0...n]**

**Mot\_temp\_mod activation / Mot\_temp\_mod act**

**Access level:** 2

**Calculated:** CALC\_MOD\_ALL

**Data type:** Unsigned16

**Can be changed:** T, U

**Scaling:** -

**Dynamic index:** MDS, p0130

**Unit group:** -

**Unit selection:** -

**Function diagram:** 8017, 8018

**Min:**

**Max:**

**Factory setting:**

-

-

0000 0010 0000 0010 bin

**Description:**

Setting to activate the motor temperature model.

**Bit field:**

Bit	Signal name	1 signal	0 signal	FP
00	Activate mot_temp_mod 1 (I2t)	Yes	No	-
01	Activate mot_temp_mod 2	Yes	No	-

08	Activate mot_temp_mod 1 (I2t) extensions	Yes	No	-
09	Activate mot_temp_mod 2 extensions	Yes	No	-
12	Mot_temp_mod 1 (I2t) ambient temperature can be adjusted	Yes (via p0613)	No (fixed 20 °C)	-

**Dependency:**

For synchronous motors and synchronous reluctance motors, when exiting commissioning, temperature model 1 is automatically activated if a time constant has been entered in p0611.

See also: r0034, p0604, p0605, p0611, p0613, p0615, p0625, p0627, r0632, p5350, r5389, p5390, p5391

See also: F07011, A07012, F07013, A07014, A07910

**NOTICE**

For bit 00:

This bit is only automatically activated for permanent-magnet 1FT7 synchronous motors and synchronous reluctance motors. For other permanent-magnet synchronous motors, the user himself must activate motor temperature model 1 (I2t).

It is only possible to activate this motor temperature model (I2t) for a time constant greater than zero (p0611 > 0).

**Note**

Mot\_temp\_mod: motor temperature model

For bit 00:

This bit is used to activate/deactivate the motor temperature model for permanent-magnet synchronous motors and synchronous reluctance motors.

For bit 01 (see also bit 9):

This bit is used to activate/deactivate the motor temperature model for induction motors.

For bit 08:

This bit is used to extend the motor temperature model 1 (I2t).

The following applies for firmware version < 4.7 SP6 (only bit 0):

- this bit has no function. Temperature model 1 operates in the standard mode.

Overtemperature at rated load: p0605 - 40 °C

Alarm threshold: p0605

Fault threshold: p0615

The following applies from firmware version 4.7 SP6 (bits 0 and 8):

- temperature model 1 operates in the extended mode.

Overtemperature at rated load: p0627

Alarm threshold: p5390

Fault threshold: p5391

For bit 09:

This bit is used to extend the motor temperature model 2.

For firmware version < 4.7 following applies (only bit 1):

- this bit has no function. Temperature model 2 operates in the standard mode.

From firmware version 4.7 the following applies (bits 1 and 9):

- this bit should be set. Temperature model 2 then operates in the extended mode and the result of the model is more precise.

For bit 12 (only effective if a temperature sensor has not been parameterized):

This bit is used to set the ambient temperature for the motor temperature model 1 (I2t).

The following applies for firmware version < 4.7 SP6 (only bit 0):

- this bit has no function. Temperature model 1 operates with an ambient temperature of 20 °C.

The following applies from firmware version 4.7 SP6 (bits 0 and 12):

- the ambient temperature can be adapted to the conditions using p0613.

**p0613[0...n]****Mot\_temp\_mod 1/3 ambient temperature / Mod 1/3 amb\_temp**

**Access level:** 2

**Can be changed:** T, U

**Unit group:** 21\_1

**Min:**

-40 [°C]

**Calculated:** -

**Scaling:** -

**Unit selection:** p0505

**Max:**

100 [°C]

**Data type:** FloatingPoint32

**Dynamic index:** MDS, p0130

**Function diagram:** 8017

**Factory setting:**

20 [°C]

7.3 Parameter list

**Description:** Sets the ambient temperature for motor temperature model 1 or 3.  
 - temperature model 1 (I2t, p0612.0 = 1):  
 For firmware version < 4.7 SP6 or p0612.12 = 0, the following applies:  
 The parameter is not relevant.  
 From firmware version 4.7 SP6 and p0612.12 = 1, the following applies:  
 The parameter defines the current ambient temperature.  
 - temperature model 3 (p0612.2 = 1):  
 The parameter defines the current ambient temperature.

**Dependency:** See also: p0612  
 See also: F07011, A07012

**p0614[0...n]**      **Thermal resistance adaptation reduction factor / Therm R\_adapt red**

<b>Access level:</b> 3	<b>Calculated:</b> -	<b>Data type:</b> FloatingPoint32
<b>Can be changed:</b> T, U	<b>Scaling:</b> -	<b>Dynamic index:</b> MDS, p0130
<b>Unit group:</b> -	<b>Unit selection:</b> -	<b>Function diagram:</b> -
<b>Min:</b> 0 [%]	<b>Max:</b> 100 [%]	<b>Factory setting:</b> 30 [%]

**Description:** Sets the reduction factor for the overtemperature of the thermal adaptation of the stator/rotor resistance.  
 The value is a starting value when switching on. Internally, after switch-on, the reduction factor has no effect corresponding to the thermal time constant.

**Dependency:** See also: p0610

**Note**  
 The reduction factor is only effective for p0610 = 12, and refers to the overtemperature.

**p0615[0...n]**      **Mot\_temp\_mod 1 (I2t) fault threshold / I2t F thresh**

<b>Access level:</b> 2	<b>Calculated:</b> -	<b>Data type:</b> FloatingPoint32
<b>Can be changed:</b> T, U	<b>Scaling:</b> -	<b>Dynamic index:</b> MDS, p0130
<b>Unit group:</b> 21_1	<b>Unit selection:</b> p0505	<b>Function diagram:</b> 8017
<b>Min:</b> 0.0 [°C]	<b>Max:</b> 220.0 [°C]	<b>Factory setting:</b> 180.0 [°C]

**Description:** Sets the fault threshold for monitoring the motor temperature for motor temperature model 1 (I2t).  
 The following applies for firmware version < 4.7 SP6:  
 - fault F07011 is output after the fault threshold is exceeded.  
 - fault threshold for r0034 = 100 % \* (p0615 - 40) / (p0605 - 40).  
 The following applies from firmware version 4.7 SP6 and p0612.8 = 1:  
 - the fault threshold in p0615 is preset when commissioning.  
 - when a catalog motor with motor temperature model 1 (I2t) is being commissioned for the first time, the threshold value is copied from p0615 to p5391.  
 - p5391 is of significance for evaluating the fault threshold.

**Dependency:** The parameter is only used for motor temperature model 1 (I2t).  
 See also: r0034, p0611, p0612  
 See also: F07011, A07012

**NOTICE**  
 When selecting a catalog motor (p0301), this parameter is automatically pre-assigned and is write protected. Information in p0300 should be carefully observed when removing write protection.

**Note**  
 The hysteresis is 2 K.

<b>p0621[0...n]</b>	<b>Identification stator resistance after restart / Rst_ident Restart</b>		
	<b>Access level:</b> 2	<b>Calculated:</b> -	<b>Data type:</b> Integer16
	<b>Can be changed:</b> T	<b>Scaling:</b> -	<b>Dynamic index:</b> MDS, p0130
	<b>Unit group:</b> -	<b>Unit selection:</b> -	<b>Function diagram:</b> -
	<b>Min:</b> 0	<b>Max:</b> 2	<b>Factory setting:</b> 0
<b>Description:</b>	<p>Selects the identification of the stator resistance of induction motors after the Control Unit runs-up (only for vector control).</p> <p>The identification is used to measure the actual stator resistance and from the ratio of the result of motor data identification (p0350) to the matching ambient temperature (p0625) the actual mean temperature of the stator winding is calculated. The result is used to initialize the thermal motor model.</p> <p>p0621 = 1: Identification of the stator resistance only when the drive is switched on for the first time (pulse enable) after booting the Control Unit.</p> <p>p0621 = 2: Identification of the stator resistance every time the drive is switched on (pulse enable).</p>		
<b>Value:</b>	<p>0: No Rs identification</p> <p>1: Rs identification after switching-on again</p> <p>2: Rs identification after switching-on each time</p>		
<b>Dependency:</b>	<p>- perform motor data identification (see p1910) with cold motor.</p> <p>- enter ambient temperature at time of motor data identification in p0625.</p> <p>See also: p0622</p>		
	<p><b>NOTICE</b></p> <p>The determined stator temperature of the induction motor can only be compared with the measured value of a temperature sensor (KTY/PT1000) to a certain extent, as the sensor is usually the warmest point of the stator winding, whereas the measured value of identification reflects the mean value of the stator winding.</p> <p>Furthermore this is a short-time measurement with limited accuracy that is performed during the magnetizing phase of the induction motor.</p>		
	<p><b>Note</b></p> <p>The measurement is carried out:</p> <ul style="list-style-type: none"> <li>- For induction motors</li> <li>- When vector control is active (see p1300)</li> <li>- if a temperature sensor (KTY/PT1000) has not been connected</li> <li>- When the motor is at a standstill when switched on</li> </ul> <p>When a flying restart is performed on a rotating motor, the temperatures of the thermal motor model are set to a third of the overtemperatures. This occurs only once, however, when the CU is booted (e.g. after a power failure).</p> <p>If identification is activated, the magnetizing time is determined via p0622 and not via p0346. Quick magnetizing (p1401.6) is de-energized internally and alarm A07416 is displayed. The speed is enabled after completion of the measurement.</p>		

<b>p0621[0...n]</b>	<b>Identification stator resistance after restart / Rst_ident Restart</b>		
CUG120X_PN (PM330)	<b>Access level:</b> 2	<b>Calculated:</b> -	<b>Data type:</b> Integer16
	<b>Can be changed:</b> T	<b>Scaling:</b> -	<b>Dynamic index:</b> MDS, p0130
	<b>Unit group:</b> -	<b>Unit selection:</b> -	<b>Function diagram:</b> -
	<b>Min:</b> 0	<b>Max:</b> 2	<b>Factory setting:</b> 0

7.3 Parameter list

**Description:** Selects the identification of the stator resistance of induction motors after the Control Unit runs-up (only for vector control).  
 The identification is used to measure the actual stator resistance and from the ratio of the result of motor data identification (p0350) to the matching ambient temperature (p0625) the actual mean temperature of the stator winding is calculated. The result is used to initialize the thermal motor model.  
 p0621 = 1:  
 Identification of the stator resistance only when the drive is switched on for the first time (pulse enable) after booting the Control Unit.  
 p0621 = 2:  
 Identification of the stator resistance every time the drive is switched on (pulse enable).  
  
 If a reference value for the stator resistance at an ambient temperature is entered into p0629, then the setting value for the stator temperature is generated from this value and not from p0350.  
 When activating the measurement (p0621 = 1, 2), p0629 is determined when first starting the drive. p0629 should be saved for subsequent use. In order that p0629 matches the ambient temperature (p0625), the function should be activated with the motor in the cold condition.

**Value:**

0: No Rs identification  
 1: Rs identification after switching-on again  
 2: Rs identification after switching-on each time

**Dependency:**

- perform motor data identification (see p1910) with cold motor.
- enter ambient temperature at time of motor data identification in p0625.
- Reference stator resistance p0629 saved after it has been determined.

See also: p0622, p0629

**NOTICE**

The calculated stator temperature can only be compared with the measured value of a temperature sensor (KTY/PT1000) to a certain extent, as the sensor is usually the warmest point of the stator winding, whereas the measured value of identification reflects the mean value of the stator winding. The accuracy depends very heavily on how precisely the motor feeder cable resistance is known (see p0352).  
 The accuracy of the measurement can be improved by entering the feeder cable resistance p0352 and by determining the reference stator resistance p0629 for the ambient temperature. p0629 is the measured value r0623, which was determined immediately after the first commissioning with the motor in a cold state. For p0621 = 1, p0629 is also measured when switching on for the first time and not after the Control Unit has switched on.

**Note**

The measurement is carried out:

- For induction motors
- When vector control is active (see p1300)
- if a temperature sensor (KTY/PT1000) has not been connected
- When the motor is at a standstill when switched on

When a flying restart is performed on a rotating motor, the temperatures of the thermal motor model are set to a third of the overtemperatures. This occurs only once, however, when the CU is booted (e.g. after a power failure).  
 If identification is activated, the magnetizing time is determined via p0622 and not via p0346. Quick magnetizing (p1401.6) is de-energized internally and alarm A07416 is displayed. The speed is enabled after completion of the measurement.

p0622[0...n]

**Motor excitation time for Rs\_ident after switching on again / t\_excit Rs\_id**

<b>Access level:</b> 3	<b>Calculated:</b> CALC_MOD_REG	<b>Data type:</b> FloatingPoint32
<b>Can be changed:</b> T, U	<b>Scaling:</b> -	<b>Dynamic index:</b> MDS, p0130
<b>Unit group:</b> -	<b>Unit selection:</b> -	<b>Function diagram:</b> -
<b>Min:</b> 0.000 [s]	<b>Max:</b> 20.000 [s]	<b>Factory setting:</b> 0.000 [s]

**Description:** Sets the excitation time of the motor for the stator resistance identification after switching on again (restart).  
**Dependency:** See also: p0621



**Note**

For p0622 < p0346 the following applies:

If identification is activated, the magnetizing time is influenced by p0622. The speed is enabled after measurement is complete, but not before the time in p0346 has elapsed (see r0056 bit 4). The time taken for measurement also depends on the settling time of the measured current.

For p0622 >= p0346 the following applies:

Parameter p0622 is internally limited to the magnetizing time p0346, so that p0346 represents the maximum possible magnetizing time during identification. The entire measurement period (magnetizing plus measurement settling time plus measuring time) will always be greater than p0346.

**p0625[0...n]****Motor ambient temperature during commissioning / Mot T\_ambient**

**Access level:** 3

**Calculated:** CALC\_MOD\_EQU **Data type:** FloatingPoint32

**Can be changed:** T, U

**Scaling:** -

**Dynamic index:** MDS, p0130

**Unit group:** 21\_1

**Unit selection:** p0505

**Function diagram:** 8017, 8018

**Min:**

**Max:**

**Factory setting:**

-40 [°C]

80 [°C]

20 [°C]

**Description:**

Defines the ambient temperature of the motor for calculating the motor temperature model.

**Dependency:**

See also: p0350, p0354

**Note**

The parameters for stator and rotor resistance (p0350, p0354) refer to this temperature.

If the thermal I2t motor model is activated for permanent-magnet synchronous motors (refer to p0611), p0625 is included in the model calculation if a temperature sensor is not being used (see p0601).

**p0627[0...n]****Motor overtemperature, stator winding / Mot T\_over stator**

**Access level:** 2

**Calculated:** CALC\_MOD\_EQU **Data type:** FloatingPoint32

**Can be changed:** T, U

**Scaling:** -

**Dynamic index:** MDS, p0130

**Unit group:** 21\_2

**Unit selection:** p0505

**Function diagram:** 8017, 8018

**Min:**

**Max:**

**Factory setting:**

15 [K]

200 [K]

80 [K]

**Description:**

Defines the rated overtemperature of the stator winding referred to the ambient temperature.

- motor temperature model 1 (I2t, p0612.0 = 1):

The following applies for firmware version < 4.7 SP6 or p0612.8 = 0:

p0605 is of significance for the rated temperature.

The following applies from firmware version 4.7 SP6 and p0612.8 = 1:

Overtemperature at the rated operating point.

- motor temperature model 2 (p0612.1 = 1):

Overtemperature at the rated operating point.

**Dependency:**

For 1LA5 and 1LA7 motors (p0300 = 15, 17), the parameter is pre-set as a function of p0307 and p0311.

See also: p0625

**NOTICE**

When selecting a standard induction motor listed in the catalog (p0300 > 100, p0301 > 10000), this parameter is automatically pre-assigned and is write protected. Information in p0300 should be carefully observed when removing write protection.

**Note**

When quick commissioning is exited with p3900 > 0, then the parameter is reset if a catalog motor has not been selected (p0300).

The signal is not suitable as a process quantity and may only be used as a display quantity.

## 7.3 Parameter list

<b>p0629[0...n]</b> CUG120X_PN (PM330)	<b>Stator resistance reference / R_stator ref</b>		
<b>Access level:</b> 3	<b>Calculated:</b> CALC_MOD_EQU	<b>Data type:</b> FloatingPoint32	
<b>Can be changed:</b> T, U	<b>Scaling:</b> -	<b>Dynamic index:</b> MDS, p0130	
<b>Unit group:</b> -	<b>Unit selection:</b> -	<b>Function diagram:</b> -	
<b>Min:</b> 0.00000 [ohm]	<b>Max:</b> 2000.00000 [ohm]	<b>Factory setting:</b> 0.00000 [ohm]	
<b>Description:</b>	Reference value for the identification of the stator resistance every time the drive is switched on.		
<b>Dependency:</b>	The measurement of the reference value is activated by the automatic calculation (p0340 = 1, 2), if the following conditions apply: - the motor temperature is at this instant in time less than 30 °C (r0035). - a temperature sensor is not being used (p0601). See also: p0621		
	<b>Note</b> The reference value to identify the stator resistance is determined at the first identification. This must be realized when the motor is in a cold state, as the value refers to the ambient temperature p0625. The feeder cable resistance should be entered into p0352 before the measurement. The result must be saved after the first measurement so that the reference is available after the CU has powered up. When changing p0350 or p0352, the reference value p0629 should be re-determined.		
<b>r0632[0...n]</b>	<b>Mot_temp_mod stator winding temperature / Mod T_winding</b>		
<b>Access level:</b> 2	<b>Calculated:</b> -	<b>Data type:</b> FloatingPoint32	
<b>Can be changed:</b> -	<b>Scaling:</b> p2006	<b>Dynamic index:</b> MDS, p0130	
<b>Unit group:</b> 21_1	<b>Unit selection:</b> p0505	<b>Function diagram:</b> 8017, 8018	
<b>Min:</b> - [°C]	<b>Max:</b> - [°C]	<b>Factory setting:</b> - [°C]	
<b>Description:</b>	Displays the stator winding temperature of the motor temperature model.		
<b>Dependency:</b>	See also: F07011, A07012, A07910		
<b>p0640[0...n]</b>	<b>Current limit / Current limit</b>		
<b>Access level:</b> 2	<b>Calculated:</b> CALC_MOD_ALL	<b>Data type:</b> FloatingPoint32	
<b>Can be changed:</b> C2(1), T, U	<b>Scaling:</b> -	<b>Dynamic index:</b> DDS, p0180	
<b>Unit group:</b> -	<b>Unit selection:</b> -	<b>Function diagram:</b> 6640, 6828	
<b>Min:</b> 0.00 [Arms]	<b>Max:</b> 10000.00 [Arms]	<b>Factory setting:</b> 0.00 [Arms]	
<b>Description:</b>	Sets the current limit.		
<b>Dependency:</b>	See also: r0209, p0323		
	<b>Note</b> The parameter is part of the quick commissioning (p0010 = 1); this means that it is appropriately pre-assigned when changing p0305. The current limit p0640 is limited to r0209. The resulting current limit is displayed in r0067 and if required, r0067 is reduced by the thermal model of the power unit. The torque and power limits (p1520, p1521, p1530, p1531) matching the current limit are automatically calculated when exiting the quick commissioning using p3900 > 0 or using the automatic parameterization with p0340 = 3, 5. p0640 is limited to 4.0 x p0305. p0640 is pre-assigned for the automatic self commissioning routine (e.g. to 1.5 x p0305, with p0305 = r0207[1]). p0640 must be entered when commissioning the system. This is the reason that p0640 is not calculated by the automatic parameterization when exiting the quick commissioning (p3900 > 0).		

<b>p0641[0...n]</b>	<b>Cl: Current limit, variable / Curr lim var</b>		
	<b>Access level:</b> 3	<b>Calculated:</b> -	<b>Data type:</b> Unsigned32 / FloatingPoint32
	<b>Can be changed:</b> T	<b>Scaling:</b> PERCENT	<b>Dynamic index:</b> CDS, p0170
	<b>Unit group:</b> -	<b>Unit selection:</b> -	<b>Function diagram:</b> 6640
	<b>Min:</b> -	<b>Max:</b> -	<b>Factory setting:</b> 1
<b>Description:</b>	Sets the signal source for the variable current limit. The value is referred to p0640.		
<b>p0644[0...n]</b>	<b>Current limit excitation induction motor / I<sub>max</sub> excitat ASM</b>		
CUG120X_PN (PM330)	<b>Access level:</b> 3	<b>Calculated:</b> -	<b>Data type:</b> FloatingPoint32
	<b>Can be changed:</b> T, U	<b>Scaling:</b> -	<b>Dynamic index:</b> DDS, p0180
	<b>Unit group:</b> -	<b>Unit selection:</b> -	<b>Function diagram:</b> -
	<b>Min:</b> 50.0 [%]	<b>Max:</b> 300.0 [%]	<b>Factory setting:</b> 300.0 [%]
<b>Description:</b>	Maximum excitation current of the induction motor referred to the permissible rated current of the power unit (r0207[0]).		
<b>Dependency:</b>	Only effective for vector control.		
	<b>Note</b> The parameter is pre-assigned in the automatic calculation for chassis power units.		
<b>p0650[0...n]</b>	<b>Actual motor operating hours / Oper hours motor</b>		
	<b>Access level:</b> 3	<b>Calculated:</b> -	<b>Data type:</b> Unsigned32
	<b>Can be changed:</b> T	<b>Scaling:</b> -	<b>Dynamic index:</b> MDS, p0130
	<b>Unit group:</b> -	<b>Unit selection:</b> -	<b>Function diagram:</b> -
	<b>Min:</b> 0 [h]	<b>Max:</b> 4294967295 [h]	<b>Factory setting:</b> 0 [h]
<b>Description:</b>	Displays the operating hours for the corresponding motor. The motor operating time counter continues to run when the pulses are enabled. When the pulse enable is withdrawn, the counter is held and the value saved.		
<b>Dependency:</b>	See also: p0651 See also: A01590		
	<b>Note</b> For p0651 = 0, the operating hours counter is disabled. The operating hours counter in p0650 can only be reset to 0. The operating hours counter only runs with drive data set 0 and 1 (DDS).		
<b>p0651[0...n]</b>	<b>Motor operating hours maintenance interval / Mot t<sub>op</sub> maint</b>		
	<b>Access level:</b> 3	<b>Calculated:</b> -	<b>Data type:</b> Unsigned32
	<b>Can be changed:</b> T	<b>Scaling:</b> -	<b>Dynamic index:</b> MDS, p0130
	<b>Unit group:</b> -	<b>Unit selection:</b> -	<b>Function diagram:</b> -
	<b>Min:</b> 0 [h]	<b>Max:</b> 150000 [h]	<b>Factory setting:</b> 0 [h]
<b>Description:</b>	Sets the service/maintenance intervals in hours for the appropriate motor. An appropriate message is output when the operating hours set here are reached.		
<b>Dependency:</b>	See also: p0650 See also: A01590		

7.3 Parameter list

**Note**

For p0651 = 0, the operating hours counter is disabled.  
 When setting p0651 to 0, then p0650 is automatically set to 0.  
 The operating hours counter only runs with drive data set 0 and 1 (DDS).

<b>r0719</b>	<b>IO extension module status / IO module status</b>		
	<b>Access level:</b> 3	<b>Calculated:</b> -	<b>Data type:</b> Unsigned16
	<b>Can be changed:</b> -	<b>Scaling:</b> -	<b>Dynamic index:</b> -
	<b>Unit group:</b> -	<b>Unit selection:</b> -	<b>Function diagram:</b> -
	<b>Min:</b> -	<b>Max:</b> -	<b>Factory setting:</b> -

**Description:** IO expansion module status

**Note**

0: IO expansion module is not connected  
 1: IO expansion module connected

<b>r0720[0...4]</b>	<b>CU number of inputs and outputs / CU I/O count</b>		
	<b>Access level:</b> 3	<b>Calculated:</b> -	<b>Data type:</b> Unsigned16
	<b>Can be changed:</b> -	<b>Scaling:</b> -	<b>Dynamic index:</b> -
	<b>Unit group:</b> -	<b>Unit selection:</b> -	<b>Function diagram:</b> 2119
	<b>Min:</b> -	<b>Max:</b> -	<b>Factory setting:</b> -

**Description:** Displays the number of inputs and outputs.

**Index:**  
 [0] = Number of digital inputs  
 [1] = Number of digital outputs  
 [2] = Number of digital input/outputs bidirectional  
 [3] = Number of analog inputs  
 [4] = Number of analog outputs

<b>r0721</b>	<b>CU digital inputs terminal actual value / CU DI term act val</b>		
	<b>Access level:</b> 2	<b>Calculated:</b> -	<b>Data type:</b> Unsigned32
	<b>Can be changed:</b> -	<b>Scaling:</b> -	<b>Dynamic index:</b> -
	<b>Unit group:</b> -	<b>Unit selection:</b> -	<b>Function diagram:</b> 2201, 2221, 2256
	<b>Min:</b> -	<b>Max:</b> -	<b>Factory setting:</b> -

**Description:** Displays the actual value at the digital inputs.

This means that the actual input signal can be checked at terminal DI x or DI/DO x prior to switching from the simulation mode (p0795.x = 1) to terminal mode (p0795.x = 0).

<b>Bit field:</b>	<b>Bit</b>	<b>Signal name</b>	<b>1 signal</b>	<b>0 signal</b>	<b>FP</b>
	00	DI 0 (X133. 5)	High	Low	-
	01	DI 1 (X133. 6)	High	Low	-
	02	DI 2 (X133. 7)	High	Low	-
	03	DI 3 (X133. 8)	High	Low	-
	04	DI 4 (X133. 16)	High	Low	-
	05	DI 5 (X133. 17)	High	Low	-
	06	DI 6 (X203. 88)	High	Low	-
	07	DI 7 (X203. 87)	High	Low	-
	11	DI 11 (X132.3, 4) AI 0	High	Low	-

12	DI 12 (X132. 10, 11) AI 1	High	Low	-
----	---------------------------	------	-----	---

**Note**

AI: Analog Input  
 DI: Digital Input  
 X203: IO module terminal

**r0722.0...12****CO/BO: CU digital inputs status / CU DI status****Access level:** 2**Calculated:** -**Data type:** Unsigned32**Can be changed:** -**Scaling:** -**Dynamic index:** -**Unit group:** -**Unit selection:** -**Function diagram:** 2201, 2221, 2256**Min:****Max:****Factory setting:**

-

-

-

**Description:**

Displays the status of the digital inputs.

**Bit field:**

Bit	Signal name	1 signal	0 signal	FP
00	DI 0 (X133. 5)	High	Low	-
01	DI 1 (X133. 6)	High	Low	-
02	DI 2 (X133. 7)	High	Low	-
03	DI 3 (X133. 8)	High	Low	-
04	DI 4 (X133. 16)	High	Low	-
05	DI 5 (X133. 17)	High	Low	-
06	DI 6 (X203. 88)	High	Low	-
07	DI 7 (X203. 87)	High	Low	-
11	DI 11 (X132.3, 4) AI 0	High	Low	-
12	DI 12 (X132. 10, 11) AI 1	High	Low	-

**Dependency:**

See also: r0723

**Note**

AI: Analog Input  
 DI: Digital Input  
 X203: IO module terminal

**r0723.0...12****CO/BO: CU digital inputs status inverted / CU DI status inv****Access level:** 3**Calculated:** -**Data type:** Unsigned32**Can be changed:** -**Scaling:** -**Dynamic index:** -**Unit group:** -**Unit selection:** -**Function diagram:** 2119, 2120, 2121, 2130, 2131, 2132, 2133**Min:****Max:****Factory setting:**

-

-

-

**Description:**

Displays the inverted status of the digital inputs.

**Bit field:**

Bit	Signal name	1 signal	0 signal	FP
00	DI 0 (X133. 5)	High	Low	-
01	DI 1 (X133. 6)	High	Low	-
02	DI 2 (X133. 7)	High	Low	-
03	DI 3 (X133. 8)	High	Low	-
04	DI 4 (X133. 16)	High	Low	-
05	DI 5 (X133. 17)	High	Low	-
06	DI 6 (X203. 88)	High	Low	-
07	DI 7 (X203. 87)	High	Low	-
11	DI 11 (X132.3, 4) AI 0	High	Low	-

7.3 Parameter list

<b>Dependency:</b>	12 DI 12 (X132. 10, 11) AI 1 See also: r0722	High	Low	-
<b>Note</b> AI: Analog Input DI: Digital Input X203: IO module terminal				

<b>p0724</b>	<b>CU digital inputs debounce time / CU DI t_debounce</b>			
	<b>Access level:</b> 3	<b>Calculated:</b> -	<b>Data type:</b> FloatingPoint32	
	<b>Can be changed:</b> T, U	<b>Scaling:</b> -	<b>Dynamic index:</b> -	
	<b>Unit group:</b> -	<b>Unit selection:</b> -	<b>Function diagram:</b> -	
	<b>Min:</b> 0.000 [ms]	<b>Max:</b> 20.000 [ms]	<b>Factory setting:</b> 4.000 [ms]	
<b>Description:</b>	Sets the debounce time for digital inputs.			
<b>Note</b> The digital inputs are read in cyclically every 2 ms (DI 11, DI 12 every 4 ms). To debounce the signals, the set debounce time is converted into integer multiple debounce clock cycles Tp (Tp = p0724 / 2 ms). DI: Digital Input				

<b>p0730</b>	<b>BI: CU signal source for terminal DO 0 / CU S_src DO 0</b>			
	<b>Access level:</b> 2	<b>Calculated:</b> -	<b>Data type:</b> Unsigned32 / Binary	
	<b>Can be changed:</b> T, U	<b>Scaling:</b> -	<b>Dynamic index:</b> -	
	<b>Unit group:</b> -	<b>Unit selection:</b> -	<b>Function diagram:</b> 2119, 2030, 2130	
	<b>Min:</b> -	<b>Max:</b> -	<b>Factory setting:</b> 52.3	
<b>Description:</b>	Sets the signal source for terminal DO 0 (NO: X134. 19 / NC: X134. 18).			
<b>Recommendation:</b>	r0052.0 Ready for switching on r0052.1 Ready for operation r0052.2 Operation enabled r0052.3 Fault present r0052.4 Coast down active (OFF2) r0052.5 Quick stop active (OFF3) r0052.6 Switching on inhibited active r0052.7 Alarm present r0052.9 Control request r0052.14 Motor rotates forwards r0053.0 DC braking active r0053.1 n_act > p2167 (n_off) r0053.2 n_act <= p1080 (n_min) r0053.3 I_act > p2170 r0053.4 n_act > p2155 r0053.5 n_act <= p2155 r0053.6 n_act >= n_set r0053.10 Technology controller output at the lower limit r0053.11 Technology controller output at the upper limit			

<b>NOTICE</b> The parameter may be protected as a result of p0922 or p2079 and cannot be changed.
--

**Note**

DO: Digital Output

Relay output: NO = normally open, NC = normally closed

**p0731****BI: CU signal source for terminal DO 1 / CU S\_src DO 1****Access level:** 2**Calculated:** -**Data type:** Unsigned32 / Binary**Can be changed:** T, U**Scaling:** -**Dynamic index:** -**Unit group:** -**Unit selection:** -**Function diagram:** 2119, 2030, 2130**Min:****Max:****Factory setting:**

-

-

52.2

**Description:**

Sets the signal source for terminal DO 1 (NO: X134. 24 / NC: X134. 23).

**Recommendation:**

r0052.0 Ready for switching on

r0052.1 Ready for operation

r0052.2 Operation enabled

r0052.3 Fault present

r0052.4 Coast down active (OFF2)

r0052.5 Quick stop active (OFF3)

r0052.6 Switching on inhibited active

r0052.7 Alarm present

r0052.9 Control request

r0052.14 Motor rotates forwards

r0053.0 DC braking active

r0053.1 n\_act &gt; p2167 (n\_off)

r0053.2 n\_act &lt;= p1080 (n\_min)

r0053.3 l\_act &gt; p2170

r0053.4 n\_act &gt; p2155

r0053.5 n\_act &lt;= p2155

r0053.6 n\_act &gt;= n\_set

r0053.10 Technology controller output at the lower limit

r0053.11 Technology controller output at the upper limit

**NOTICE**

The parameter may be protected as a result of p0922 or p2079 and cannot be changed.

**Note**

DO: Digital Output

Relay output: NO = normally open, NC = normally closed

**p0732****BI: CU signal source for terminal DO 2 / CU S\_src DO 2****Access level:** 2**Calculated:** -**Data type:** Unsigned32 / Binary**Can be changed:** T, U**Scaling:** -**Dynamic index:** -**Unit group:** -**Unit selection:** -**Function diagram:** 2119, 2030, 2130**Min:****Max:****Factory setting:**

-

-

52.0

**Description:**

Sets the signal source for terminal DO 2 (NO: X204. 98 / NC: X204. 99).

7.3 Parameter list

- Recommendation:**
- r0052.0 Ready for switching on
  - r0052.1 Ready for operation
  - r0052.2 Operation enabled
  - r0052.3 Fault present
  - r0052.4 Coast down active (OFF2)
  - r0052.5 Quick stop active (OFF3)
  - r0052.6 Switching on inhibited active
  - r0052.7 Alarm present
  - r0052.9 Control request
  - r0052.14 Motor rotates forwards
  - r0053.0 DC braking active
  - r0053.1 n\_act > p2167 (n\_off)
  - r0053.2 n\_act <= p1080 (n\_min)
  - r0053.3 l\_act > p2170
  - r0053.4 n\_act > p2155
  - r0053.5 n\_act <= p2155
  - r0053.6 n\_act >= n\_set
  - r0053.10 Technology controller output at the lower limit
  - r0053.11 Technology controller output at the upper limit

<b>NOTICE</b>
The parameter may be protected as a result of p0922 or p2079 and cannot be changed.

**Note**  
 DO: Digital Output  
 X204: IO module terminal  
 Relay output: NO = normally open, NC = normally closed

<b>p0733</b>	<b>BI: CU signal source for terminal DO 3 / CU S_src DO 3</b>		
	<b>Access level:</b> 2	<b>Calculated:</b> -	<b>Data type:</b> Unsigned32 / Binary
	<b>Can be changed:</b> T, U	<b>Scaling:</b> -	<b>Dynamic index:</b> -
	<b>Unit group:</b> -	<b>Unit selection:</b> -	<b>Function diagram:</b> -
	<b>Min:</b> -	<b>Max:</b> -	<b>Factory setting:</b> 52.7

**Description:** Sets the signal source for terminal DO 3 (NO: X204. 95 / NC: X204. 96).

<b>NOTICE</b>
The parameter may be protected as a result of p0922 or p2079 and cannot be changed.

**Note**  
 DO: Digital Output  
 X204: IO module terminal  
 Relay output: NO = normally open, NC = normally closed

<b>p0734</b>	<b>BI: CU signal source for terminal DO 4 / CU S_src DI/DO 4</b>		
	<b>Access level:</b> 2	<b>Calculated:</b> -	<b>Data type:</b> Unsigned32 / Binary
	<b>Can be changed:</b> T, U	<b>Scaling:</b> -	<b>Dynamic index:</b> -
	<b>Unit group:</b> -	<b>Unit selection:</b> -	<b>Function diagram:</b> -
	<b>Min:</b> -	<b>Max:</b> -	<b>Factory setting:</b> 0

**Description:** Sets the signal source for terminal DO 4 (NO: X204. 93).

<b>NOTICE</b>
The parameter may be protected as a result of p0922 or p2079 and cannot be changed.



**Note**

DO: Digital Output  
 X204: IO module terminal  
 Relay output: NO = normally open

**p0735****BI: CU signal source for terminal DO 5 / CU S\_src DI/DO 5**

<b>Access level:</b> 2	<b>Calculated:</b> -	<b>Data type:</b> Unsigned32 / Binary
<b>Can be changed:</b> T, U	<b>Scaling:</b> -	<b>Dynamic index:</b> -
<b>Unit group:</b> -	<b>Unit selection:</b> -	<b>Function diagram:</b> -
<b>Min:</b>	<b>Max:</b>	<b>Factory setting:</b>
-	-	0

**Description:**

Sets the signal source for terminal DO 5 (NO: x204. 91).

**NOTICE**

The parameter may be protected as a result of p0922 or p2079 and cannot be changed.

**Note**

DO: Digital Output  
 X204: IO module terminal  
 Relay output: NO = normally open

**r0747****CU digital outputs status / CU DO status**

<b>Access level:</b> 3	<b>Calculated:</b> -	<b>Data type:</b> Unsigned32
<b>Can be changed:</b> -	<b>Scaling:</b> -	<b>Dynamic index:</b> -
<b>Unit group:</b> -	<b>Unit selection:</b> -	<b>Function diagram:</b> 2130, 2131, 2132, 2133
<b>Min:</b>	<b>Max:</b>	<b>Factory setting:</b>
-	-	-

**Description:**

Displays the status of digital outputs.

**Bit field:**

Bit	Signal name	1 signal	0 signal	FP
00	DO 0 (NO: X134. 19 / NC: X134. 18)	High	Low	-
01	DO 1 (NO: X134. 24 / NC: X134. 23)	High	Low	-
02	DO 2 (NO: X204. 98 / NC: X204. 99)	High	Low	-
03	DO 3 (NO: X204. 95 / NC: X204. 96)	High	Low	-
04	DO 4 (NO: X204. 93)	High	Low	-
05	DO 5 (NO: X204. 91)	High	Low	-

**Note**

DO: Digital Output  
 X204: IO module terminal  
 Relay output: NO = normally open, NC = normally closed  
 Inversion using p0748 has been taken into account.

**p0748****CU invert digital outputs / CU DO inv**

<b>Access level:</b> 3	<b>Calculated:</b> -	<b>Data type:</b> Unsigned32
<b>Can be changed:</b> T, U	<b>Scaling:</b> -	<b>Dynamic index:</b> -
<b>Unit group:</b> -	<b>Unit selection:</b> -	<b>Function diagram:</b> 2201, 2242
<b>Min:</b>	<b>Max:</b>	<b>Factory setting:</b>
-	-	0000 0000 bin

**Description:**

Setting to invert the signals at the digital outputs.

**Bit field:**

Bit	Signal name	1 signal	0 signal	FP
00	DO 0 (NO: X134. 19 / NC: X134. 18)	Inverted	Not inverted	-



<b>p0753[0...3]</b>	<b>CU analog inputs smoothing time constant / CU AI T_smooth</b>		
	<b>Access level:</b> 3	<b>Calculated:</b> -	<b>Data type:</b> FloatingPoint32
	<b>Can be changed:</b> T, U	<b>Scaling:</b> -	<b>Dynamic index:</b> -
	<b>Unit group:</b> -	<b>Unit selection:</b> -	<b>Function diagram:</b> 9566, 9568, 9576
	<b>Min:</b> 0.0 [ms]	<b>Max:</b> 1000.0 [ms]	<b>Factory setting:</b> 0.0 [ms]
<b>Description:</b>	Sets the smoothing time constant of the 1st order lowpass filter for the analog inputs.		
<b>Index:</b>	[0] = AI0 (X132 3/4) [1] = AI1 (X132 10/11) [2] = NI 1000 0 (X202 80/82) [3] = NI 1000 1 (X202 81/82)		
	<b>Note</b> AI: Analog Input X202: IO module terminal		
<b>r0755[0...3]</b>	<b>CO: CU analog inputs actual value in percent / CU AI value in %</b>		
	<b>Access level:</b> 2	<b>Calculated:</b> -	<b>Data type:</b> FloatingPoint32
	<b>Can be changed:</b> -	<b>Scaling:</b> PERCENT	<b>Dynamic index:</b> -
	<b>Unit group:</b> -	<b>Unit selection:</b> -	<b>Function diagram:</b> 9566, 9568, 9576
	<b>Min:</b> - [%]	<b>Max:</b> - [%]	<b>Factory setting:</b> - [%]
<b>Description:</b>	Displays the currently referred input value of the analog inputs. When interconnected, the signals are referred to the reference quantities p200x and p205x.		
<b>Index:</b>	[0] = AI0 (X132 3/4) [1] = AI1 (X132 10/11) [2] = NI 1000 0 (X202 80/82) [3] = NI 1000 1 (X202 81/82)		
	<b>Note</b> AI: Analog Input X202: IO module terminal		
<b>p0756[0...3]</b>	<b>CU analog inputs type / CU AI type</b>		
	<b>Access level:</b> 2	<b>Calculated:</b> -	<b>Data type:</b> Integer16
	<b>Can be changed:</b> T, U	<b>Scaling:</b> -	<b>Dynamic index:</b> -
	<b>Unit group:</b> -	<b>Unit selection:</b> -	<b>Function diagram:</b> 9566, 9568, 9576
	<b>Min:</b> 0	<b>Max:</b> 10	<b>Factory setting:</b> [0] 4 [1] 4 [2] 8 [3] 8

7.3 Parameter list

**Description:** Sets the type of analog inputs.  
 p0756[0...1] = 0, 1, 4 corresponds to a voltage input (r0752, p0757, p0759 are displayed in V).  
 p0756[0...2] = 2, 3 corresponds to a current input (r0752, p0757, p0759 are displayed in mA).  
 p0756[2...3] = 6, 7, 10 corresponds to a resistor input for temperature measurement (r0752, p0757, p0759 are displayed in °C).  
 p0756[2...3] = 8 No temperature sensor connected. Mode for deactivating sensor monitoring (alarm A03520).  
 In addition, the associated DIP switch must be set.  
 For the voltage input, DIP switch AI0/1 must be set to "U".  
 For the current input, DIP switch AI0/1 or AI2 must be set to "I".  
 For the temperature input, DIP switch AI2 must be set to "TEMP".

**Value:**

- 0: Unipolar voltage input (0 V ... +10 V)
- 1: Unipolar voltage input monitored (+2 V ... +10 V)
- 2: Unipolar current input (0 mA ... +20 mA)
- 3: Unipolar current input monitored (+4 mA to +20 mA)
- 4: Bipolar voltage input (-10 V ... +10 V)
- 6: Temperature sensor LG-Ni1000
- 7: Temperature sensor PT1000
- 8: No sensor connected
- 10: Temperature sensor DIN Ni 1k (6180 ppm / K)

**Index:**

- [0] = AI0 (X132 3/4)
- [1] = AI1 (X132 10/11)
- [2] = NI 1000 0 (X202 80/82)
- [3] = NI 1000 1 (X202 81/82)

**Dependency:** See also: A03520

**⚠ WARNING**

The maximum voltage difference between analog input terminals AI+, AI-, and the ground must not exceed 35 V. If the system is operated when the load resistor is switched on (DIP switch set to "I"), the voltage between differential inputs AI+ and AI- must not exceed 10 V or the injected 80 mA current otherwise the input will be damaged.

**Note**

When changing p0756, the parameters of the scaling characteristic (p0757, p0758, p0759, p0760) are overwritten with the following default values:  
 For p0756 = 0, 4, p0757 is set to 0.0 V, p0758 = 0.0 %, p0759 = 10.0 V and p0760 = 100.0 %.  
 For p0756 = 1, p0757 is set to 2.0 V, p0758 = 0.0 %, p0759 = 10.0 V and p0760 = 100.0 %.  
 For p0756 = 2, p0757 is set to 0.0 mA, p0758 = 0.0 %, p0759 = 20.0 mA and p0760 = 100.0 %.  
 For p0756 = 3, p0757 is set to 4.0 mA, p0758 = 0.0 %, p0759 = 20.0 mA and p0760 = 100.0 %.  
 For p0756 = 6, 7, p0757 is set to 0 °C, p0758 = 0.0 %, p0759 = 100 °C and p0760 = 100.0 %.

X202: IO module terminal

<b>p0757[0...3]</b>	<b>CU analog inputs characteristic value x1 / CU AI char x1</b>		
<b>Access level:</b> 2	<b>Calculated:</b> -	<b>Data type:</b> FloatingPoint32	
<b>Can be changed:</b> T, U	<b>Scaling:</b> -	<b>Dynamic index:</b> -	
<b>Unit group:</b> -	<b>Unit selection:</b> -	<b>Function diagram:</b> 9566, 9568, 9576	
<b>Min:</b> -50.000	<b>Max:</b> 160.000	<b>Factory setting:</b> 0.000	

**Description:** Sets the scaling characteristic for the analog inputs.  
 The scaling characteristic for the analog inputs is defined using 2 points.  
 This parameter specifies the x coordinate (V, mA, °C) of the 1st value pair of the characteristic.

**Index:**  
 [0] = AI0 (X132 3/4)  
 [1] = AI1 (X132 10/11)  
 [2] = NI 1000 0 (X202 80/82)  
 [3] = NI 1000 1 (X202 81/82)

**Note**

The parameters for the characteristic do not have a limiting effect.  
 X202: IO module terminal

**p0758[0...3] CU analog inputs characteristic value y1 / CU AI char y1****Access level:** 2**Calculated:** -**Data type:** FloatingPoint32**Can be changed:** T, U**Scaling:** -**Dynamic index:** -**Unit group:** -**Unit selection:** -**Function diagram:** 9566, 9568, 9576**Min:****Max:****Factory setting:**

-1000.00 [%]

1000.00 [%]

0.00 [%]

**Description:**

Sets the scaling characteristic for the analog inputs.

The scaling characteristic for the analog inputs is defined using 2 points.

This parameter specifies the y coordinate (percentage) of the 1st value pair of the characteristic.

**Index:**

[0] = AI0 (X132 3/4)  
 [1] = AI1 (X132 10/11)  
 [2] = NI 1000 0 (X202 80/82)  
 [3] = NI 1000 1 (X202 81/82)

**Note**

The parameters for the characteristic do not have a limiting effect.  
 X202: IO module terminal

**p0759[0...3] CU analog inputs characteristic value x2 / CU AI char x2****Access level:** 2**Calculated:** -**Data type:** FloatingPoint32**Can be changed:** T, U**Scaling:** -**Dynamic index:** -**Unit group:** -**Unit selection:** -**Function diagram:** 9566, 9568, 9576**Min:****Max:****Factory setting:**

-50.000

160.000

[0] 10.000

[1] 10.000

[2] 20.000

[3] 100.000

**Description:**

Sets the scaling characteristic for the analog inputs.

The scaling characteristic for the analog inputs is defined using 2 points.

This parameter specifies the x coordinate (V, mA, °C) of the 2nd value pair of the characteristic.

**Index:**

[0] = AI0 (X132 3/4)  
 [1] = AI1 (X132 10/11)  
 [2] = NI 1000 0 (X202 80/82)  
 [3] = NI 1000 1 (X202 81/82)

**Note**

The parameters for the characteristic do not have a limiting effect.  
 X202: IO module terminal

---

<b>p0760[0...3]</b>	<b>CU analog inputs characteristic value y2 / CU AI char y2</b>		
	<b>Access level:</b> 2	<b>Calculated:</b> -	<b>Data type:</b> FloatingPoint32
	<b>Can be changed:</b> T, U	<b>Scaling:</b> -	<b>Dynamic index:</b> -
	<b>Unit group:</b> -	<b>Unit selection:</b> -	<b>Function diagram:</b> 9566, 9568, 9576
	<b>Min:</b> -1000.00 [%]	<b>Max:</b> 1000.00 [%]	<b>Factory setting:</b> 100.00 [%]
<b>Description:</b>	Sets the scaling characteristic for the analog inputs. The scaling characteristic for the analog inputs is defined using 2 points. This parameter specifies the y coordinate (percentage) of the 2nd value pair of the characteristic.		
<b>Index:</b>	[0] = AI0 (132 3/4) [1] = AI1 (132 10/11) [2] = NI 1000 0 (X202 80/82) [3] = NI 1000 1 (X202 81/82)		
	<b>Note</b> The parameters for the characteristic do not have a limiting effect. X202: IO module terminal		

---

<b>p0761[0...3]</b>	<b>CU analog inputs wire breakage monitoring response threshold / CU WireBrkThresh</b>		
	<b>Access level:</b> 2	<b>Calculated:</b> -	<b>Data type:</b> FloatingPoint32
	<b>Can be changed:</b> T, U	<b>Scaling:</b> -	<b>Dynamic index:</b> -
	<b>Unit group:</b> -	<b>Unit selection:</b> -	<b>Function diagram:</b> 9566, 9568
	<b>Min:</b> 0.00	<b>Max:</b> 20.00	<b>Factory setting:</b> 2.00
<b>Description:</b>	Sets the response threshold for the wire breakage monitoring of the analog inputs. The unit for the parameter value depends on the set analog input type.		
<b>Index:</b>	[0] = AI0 (X132 3/4) [1] = AI1 (X132 10/11) [2] = NI 1000 0 (X202 80/82) [3] = NI 1000 1 (X202 81/82)		
<b>Dependency:</b>	For the following analog input type, the wire breakage monitoring is active: p0756[0...1] = 1 (unipolar voltage input monitored (+2 V ... +10 V)), unit [V] p0756[0...2] = 3 (unipolar current input monitored (+4 mA ... +20 mA)), unit [mA] p0756[3]: Wire breakage monitoring is not supported for this analog input. See also: p0756		
	<b>Note</b> AI: Analog Input When p0761 = 0, wire breakage monitoring is not carried out. X202: IO module terminal		

---

<b>p0762[0...3]</b>	<b>CU analog inputs wire breakage monitoring delay time / CU wire brk t_del</b>		
	<b>Access level:</b> 3	<b>Calculated:</b> -	<b>Data type:</b> Unsigned16
	<b>Can be changed:</b> T, U	<b>Scaling:</b> -	<b>Dynamic index:</b> -
	<b>Unit group:</b> -	<b>Unit selection:</b> -	<b>Function diagram:</b> 9566, 9568
	<b>Min:</b> 0 [ms]	<b>Max:</b> 1000 [ms]	<b>Factory setting:</b> 100 [ms]
<b>Description:</b>	Sets the delay time for the wire breakage monitoring of the analog inputs.		

**Index:** [0] = AI0 (X132 3/4)  
 [1] = AI1 (X132 10/11)  
 [2] = NI 1000 0 (X202 80/82)  
 [3] = NI 1000 1 (X202 81/82)

**Note**

AI: Analog Input  
 X202: IO module terminal

**p0764[0...3] CU analog inputs dead zone / CU AI dead zone**

<b>Access level:</b> 2	<b>Calculated:</b> -	<b>Data type:</b> FloatingPoint32
<b>Can be changed:</b> T, U	<b>Scaling:</b> -	<b>Dynamic index:</b> -
<b>Unit group:</b> -	<b>Unit selection:</b> -	<b>Function diagram:</b> 2251
<b>Min:</b> 0.000	<b>Max:</b> 20.000	<b>Factory setting:</b> 0.000

**Description:** Determines the width of the dead zone at the analog input.  
 Analog input type unipolar (e.g. 0 ... +10 V):  
 The dead zone starts with the characteristic value x1/y1 (p0757/p0758).  
 Analog input type bipolar (e.g. -10 V ... +10 V):  
 The dead zone is located at the symmetrical center between characteristic value x1/y1 (p0757/p0758) and x2/y2 (p0759/p0760). The set value doubles the dead zone.

**Index:** [0] = AI0 (132 3/4)  
 [1] = AI1 (132 10/11)  
 [2] = NI 1000 0 (X202 80/82)  
 [3] = NI 1000 1 (X202 81/82)

**Note**

AI: Analog Input  
 X202: IO module terminal

**p0771[0...2] CI: CU analog outputs signal source / CU AO S\_src**

<b>Access level:</b> 2	<b>Calculated:</b> -	<b>Data type:</b> Unsigned32 / FloatingPoint32
<b>Can be changed:</b> T, U	<b>Scaling:</b> PERCENT	<b>Dynamic index:</b> -
<b>Unit group:</b> -	<b>Unit selection:</b> -	<b>Function diagram:</b> 2261
<b>Min:</b> -	<b>Max:</b> -	<b>Factory setting:</b> [0] 21[0] [1] 27[0] [2] 0

**Description:** Sets the signal source for the analog outputs.

**Index:** [0] = AO0 (X133 12/13)  
 [1] = AO1 (X202 85/86)  
 [2] = AO2 (X202 83/84)

**Note**

AO: Analog Output  
 X202: IO module terminal

---

<b>r0772[0...2]</b>	<b>CU analog outputs output value currently referred / CU AO outp act ref</b>		
	<b>Access level:</b> 3	<b>Calculated:</b> -	<b>Data type:</b> FloatingPoint32
	<b>Can be changed:</b> -	<b>Scaling:</b> -	<b>Dynamic index:</b> -
	<b>Unit group:</b> -	<b>Unit selection:</b> -	<b>Function diagram:</b> 9572
	<b>Min:</b> - [%]	<b>Max:</b> - [%]	<b>Factory setting:</b> - [%]
<b>Description:</b>	Displays the actual referred output value of the analog outputs.		
<b>Index:</b>	[0] = AO0 (X133 12/13) [1] = AO1 (X202 85/86) [2] = AO2 (X202 83/84)		

---

**Note**

AO: Analog Output  
X202: IO module terminal

---



---

<b>p0773[0...2]</b>	<b>CU analog outputs smoothing time constant / CU AO T_smooth</b>		
	<b>Access level:</b> 2	<b>Calculated:</b> -	<b>Data type:</b> FloatingPoint32
	<b>Can be changed:</b> T, U	<b>Scaling:</b> -	<b>Dynamic index:</b> -
	<b>Unit group:</b> -	<b>Unit selection:</b> -	<b>Function diagram:</b> 9572
	<b>Min:</b> 0.0 [ms]	<b>Max:</b> 1000.0 [ms]	<b>Factory setting:</b> 0.0 [ms]
<b>Description:</b>	Sets the smoothing time constant of the 1st order lowpass filter for the analog outputs.		
<b>Index:</b>	[0] = AO0 (X133 12/13) [1] = AO1 (X202 85/86) [2] = AO2 (X202 83/84)		

---

**Note**

AO: Analog Output  
X202: IO module terminal

---



---

<b>r0774[0...2]</b>	<b>CU analog outputs output voltage/current actual / CU AO U/I_outp</b>		
	<b>Access level:</b> 2	<b>Calculated:</b> -	<b>Data type:</b> FloatingPoint32
	<b>Can be changed:</b> -	<b>Scaling:</b> p2001	<b>Dynamic index:</b> -
	<b>Unit group:</b> -	<b>Unit selection:</b> -	<b>Function diagram:</b> 9572
	<b>Min:</b> -	<b>Max:</b> -	<b>Factory setting:</b> -
<b>Description:</b>	Displays the actual output voltage or output current at the analog outputs.		
<b>Index:</b>	[0] = AO0 (X133 12/13) [1] = AO1 (X202 85/86) [2] = AO2 (X202 83/84)		
<b>Dependency:</b>	See also: p0776		

---

**Note**

AO: Analog Output  
X202: IO module terminal

---



---

<b>p0775[0...2]</b>	<b>CU analog outputs activate absolute value generation / CU AO absVal act</b>		
	<b>Access level:</b> 2	<b>Calculated:</b> -	<b>Data type:</b> Integer16
	<b>Can be changed:</b> T	<b>Scaling:</b> -	<b>Dynamic index:</b> -
	<b>Unit group:</b> -	<b>Unit selection:</b> -	<b>Function diagram:</b> 9572
	<b>Min:</b> 0	<b>Max:</b> 1	<b>Factory setting:</b> 0

---



**Description:** Activates the absolute value generation for the analog outputs.

**Value:** 0: No absolute value generation  
1: Absolute value generation switched in

**Index:** [0] = AO0 (X133 12/13)  
[1] = AO1 (X202 85/86)  
[2] = AO2 (X202 83/84)

**Note**

AO: Analog Output  
X202: IO module terminal

**p0776[0...2] CU analog outputs type / CU AO type**

<b>Access level:</b> 2	<b>Calculated:</b> -	<b>Data type:</b> Integer16
<b>Can be changed:</b> T, U	<b>Scaling:</b> -	<b>Dynamic index:</b> -
<b>Unit group:</b> -	<b>Unit selection:</b> -	<b>Function diagram:</b> 9572
<b>Min:</b> 0	<b>Max:</b> 2	<b>Factory setting:</b> 0

**Description:** Sets the analog output type.

p0776[x] = 1 corresponds to a voltage output (p0774, p0778, p0780 are displayed in V).  
p0776[x] = 0, 2 corresponds to a current output (p0774, p0778, p0780 are displayed in mA).

**Value:** 0: Current output (0 mA ... +20 mA)  
1: Voltage output (0 V ... +10 V)  
2: Current output (+4 mA ... +20 mA)

**Index:** [0] = AO0 (X133 12/13)  
[1] = AO1 (X202 85/86)  
[2] = AO2 (X202 83/84)

**Note**

When changing p0776, the parameters of the scaling characteristic (p0777, p0778, p0779, p0780) are overwritten with the following default values:

For p0776 = 0, p0777 is set to 0.0 %, p0778 = 0.0 mA, p0779 = 100.0 % and p0780 to 20.0 mA.

For p0776 = 1, p0777 is set to 0.0 %, p0778 = 0.0 V, p0779 = 100.0 % and p0780 to 10.0 V.

For p0776 = 2, p0777 is set to 0.0 %, p0778 = 4.0 mA, p0779 = 100.0 % and p0780 to 20.0 mA.

X202: IO module terminal

**p0777[0...2] CU analog outputs characteristic value x1 / CU AO char x1**

<b>Access level:</b> 2	<b>Calculated:</b> -	<b>Data type:</b> FloatingPoint32
<b>Can be changed:</b> T, U	<b>Scaling:</b> -	<b>Dynamic index:</b> -
<b>Unit group:</b> -	<b>Unit selection:</b> -	<b>Function diagram:</b> 9572
<b>Min:</b> -1000.00 [%]	<b>Max:</b> 1000.00 [%]	<b>Factory setting:</b> 0.00 [%]

**Description:** Sets the scaling characteristic for the analog outputs.

The scaling characteristic for the analog outputs is defined using 2 points.

This parameter specifies the x coordinate (percentage) of the 1st value pair of the characteristic.

**Index:** [0] = AO0 (X133 12/13)  
[1] = AO1 (X202 85/86)  
[2] = AO2 (X202 83/84)

**Dependency:** See also: p0776

**NOTICE**

This parameter is automatically overwritten when changing p0776 (type of analog outputs).

7.3 Parameter list

**Note**

The parameters for the characteristic do not have a limiting effect.  
X202: IO module terminal

**p0778[0...2]**

**CU analog outputs characteristic value y1 / CU AO char y1**

<b>Access level:</b> 2	<b>Calculated:</b> -	<b>Data type:</b> FloatingPoint32
<b>Can be changed:</b> T, U	<b>Scaling:</b> -	<b>Dynamic index:</b> -
<b>Unit group:</b> -	<b>Unit selection:</b> -	<b>Function diagram:</b> 9572
<b>Min:</b> -20.000 [V]	<b>Max:</b> 20.000 [V]	<b>Factory setting:</b> 0.000 [V]

**Description:**

Sets the scaling characteristic for the analog outputs.  
The scaling characteristic for the analog outputs is defined using 2 points.  
This parameter specifies the y coordinate (output voltage in V or output current in mA) of the 1st value pair of the characteristic.

**Index:**

[0] = AO0 (X133 12/13)  
[1] = AO1 (X202 85/86)  
[2] = AO2 (X202 83/84)

**Dependency:**

The unit of this parameter (V or mA) depends on the analog output type.  
See also: p0776

**NOTICE**

This parameter is automatically overwritten when changing p0776 (type of analog outputs).

**Note**

The parameters for the characteristic do not have a limiting effect.  
X202: IO module terminal

**p0779[0...2]**

**CU analog outputs characteristic value x2 / CU AO char x2**

<b>Access level:</b> 2	<b>Calculated:</b> -	<b>Data type:</b> FloatingPoint32
<b>Can be changed:</b> T, U	<b>Scaling:</b> -	<b>Dynamic index:</b> -
<b>Unit group:</b> -	<b>Unit selection:</b> -	<b>Function diagram:</b> 9572
<b>Min:</b> -1000.00 [%]	<b>Max:</b> 1000.00 [%]	<b>Factory setting:</b> 100.00 [%]

**Description:**

Sets the scaling characteristic for the analog outputs.  
The scaling characteristic for the analog outputs is defined using 2 points.  
This parameter specifies the x coordinate (percentage) of the 2nd value pair of the characteristic.

**Index:**

[0] = AO0 (X133 12/13)  
[1] = AO1 (X202 85/86)  
[2] = AO2 (X202 83/84)

**Dependency:**

See also: p0776

**NOTICE**

This parameter is automatically overwritten when changing p0776 (type of analog outputs).

**Note**

The parameters for the characteristic do not have a limiting effect.  
X202: IO module terminal

<b>p0780[0...2]</b>	<b>CU analog outputs characteristic value y2 / CU AO char y2</b>				
	<b>Access level:</b> 2	<b>Calculated:</b> -	<b>Data type:</b> FloatingPoint32		
	<b>Can be changed:</b> T, U	<b>Scaling:</b> -	<b>Dynamic index:</b> -		
	<b>Unit group:</b> -	<b>Unit selection:</b> -	<b>Function diagram:</b> 9572		
	<b>Min:</b> -20.000 [V]	<b>Max:</b> 20.000 [V]	<b>Factory setting:</b> 20.000 [V]		
<b>Description:</b>	Sets the scaling characteristic for the analog outputs. The scaling characteristic for the analog outputs is defined using 2 points. This parameter specifies the y coordinate (output voltage in V or output current in mA) of the 2nd value pair of the characteristic.				
<b>Index:</b>	[0] = AO0 (X133 12/13) [1] = AO1 (X202 85/86) [2] = AO2 (X202 83/84)				
<b>Dependency:</b>	The unit of this parameter (V or mA) depends on the analog output type. See also: p0776				
<b>NOTICE</b>					
This parameter is automatically overwritten when changing p0776 (type of analog outputs).					
<b>Note</b> The parameters for the characteristic do not have a limiting effect. X202: IO module terminal					
<b>p0782[0...2]</b>	<b>BI: CU analog outputs invert signal source / CU AO inv S_src</b>				
	<b>Access level:</b> 3	<b>Calculated:</b> -	<b>Data type:</b> Unsigned32 / Binary		
	<b>Can be changed:</b> T, U	<b>Scaling:</b> -	<b>Dynamic index:</b> -		
	<b>Unit group:</b> -	<b>Unit selection:</b> -	<b>Function diagram:</b> 9572		
	<b>Min:</b> -	<b>Max:</b> -	<b>Factory setting:</b> 0		
<b>Description:</b>	Sets the signal source to invert the analog output signals.				
<b>Index:</b>	[0] = AO0 (X133 12/13) [1] = AO1 (X202 85/86) [2] = AO2 (X202 83/84)				
<b>Note</b> AO: Analog Output X202: IO module terminal					
<b>r0785.0...2</b>	<b>BO: CU analog outputs status word / CU AO ZSW</b>				
	<b>Access level:</b> 3	<b>Calculated:</b> -	<b>Data type:</b> Unsigned16		
	<b>Can be changed:</b> -	<b>Scaling:</b> -	<b>Dynamic index:</b> -		
	<b>Unit group:</b> -	<b>Unit selection:</b> -	<b>Function diagram:</b> 9572		
	<b>Min:</b> -	<b>Max:</b> -	<b>Factory setting:</b> -		
<b>Description:</b>	Displays the status of analog outputs.				
<b>Bit field:</b>	<b>Bit</b>	<b>Signal name</b>	<b>1 signal</b>	<b>0 signal</b>	<b>FP</b>
	00	AO 0 negative	Yes	No	-
	01	AO 1 negative	Yes	No	-
	02	AO 2 negative	Yes	No	-
<b>Note</b> AO: Analog Output					

7.3 Parameter list

<b>p0795</b>	<b>CU digital inputs simulation mode / CU DI simulation</b>				
<b>Access level:</b> 3	<b>Calculated:</b> -	<b>Data type:</b> Unsigned32			
<b>Can be changed:</b> T, U	<b>Scaling:</b> -	<b>Dynamic index:</b> -			
<b>Unit group:</b> -	<b>Unit selection:</b> -	<b>Function diagram:</b> 2201, 2221, 2256			
<b>Min:</b> -	<b>Max:</b> -	<b>Factory setting:</b> 0000 0000 0000 0000 bin			
<b>Description:</b>	Sets the simulation mode for digital inputs.				
<b>Bit field:</b>	<b>Bit</b>	<b>Signal name</b>	<b>1 signal</b>	<b>0 signal</b>	<b>FP</b>
	00	DI 0 (X133. 5)	Simulation	Terminal eval	-
	01	DI 1 (X133. 6)	Simulation	Terminal eval	-
	02	DI 2 (X133. 7)	Simulation	Terminal eval	-
	03	DI 3 (X133. 8)	Simulation	Terminal eval	-
	04	DI 4 (X133. 16)	Simulation	Terminal eval	-
	05	DI 5 (X133. 17)	Simulation	Terminal eval	-
	06	DI 6 (X203. 88)	Simulation	Terminal eval	-
	07	DI 7 (X203. 87)	Simulation	Terminal eval	-
	11	DI 11 (X132. 3, 4) AI 0	Simulation	Terminal eval	-
	12	DI 12 (X132. 10, 11) AI 1	Simulation	Terminal eval	-
<b>Dependency:</b>	The setpoint for the input signals is specified using p0796. See also: p0796				
<b>Note</b>					
This parameter is not saved when data is backed up (p0971).					
AI: Analog Input					
DI: Digital Input					
X203: IO module terminal					

<b>p0796</b>	<b>CU digital inputs simulation mode setpoint / CU DI simul setp</b>				
<b>Access level:</b> 3	<b>Calculated:</b> -	<b>Data type:</b> Unsigned32			
<b>Can be changed:</b> T, U	<b>Scaling:</b> -	<b>Dynamic index:</b> -			
<b>Unit group:</b> -	<b>Unit selection:</b> -	<b>Function diagram:</b> 2201, 2221, 2256			
<b>Min:</b> -	<b>Max:</b> -	<b>Factory setting:</b> 0000 0000 0000 0000 bin			
<b>Description:</b>	Sets the setpoint for the input signals in the digital input simulation mode.				
<b>Bit field:</b>	<b>Bit</b>	<b>Signal name</b>	<b>1 signal</b>	<b>0 signal</b>	<b>FP</b>
	00	DI 0 (X133. 5)	High	Low	-
	01	DI 1 (X133. 6)	High	Low	-
	02	DI 2 (X133. 7)	High	Low	-
	03	DI 3 (X133. 8)	High	Low	-
	04	DI 4 (X133. 16)	High	Low	-
	05	DI 5 (X133. 17)	High	Low	-
	06	DI 6 (X203. 88)	High	Low	-
	07	DI 7 (X203. 87)	High	Low	-
	11	DI 11 (X132.3, 4) AI 0	High	Low	-
	12	DI 12 (X132. 10, 11) AI 1	High	Low	-
<b>Dependency:</b>	The simulation of a digital input is selected using p0795. See also: p0795				

**Note**

This parameter is not saved when data is backed up (p0971).

AI: Analog Input

DI: Digital Input

X203: IO module terminal

---

<b>p0797[0...3]</b>	<b>CU analog inputs simulation mode / CU AI sim_mode</b>		
	<b>Access level:</b> 3	<b>Calculated:</b> -	<b>Data type:</b> Integer16
	<b>Can be changed:</b> T, U	<b>Scaling:</b> -	<b>Dynamic index:</b> -
	<b>Unit group:</b> -	<b>Unit selection:</b> -	<b>Function diagram:</b> -
	<b>Min:</b> 0	<b>Max:</b> 1	<b>Factory setting:</b> 0
<b>Description:</b>	Sets the simulation mode for the analog inputs.		
<b>Value:</b>	0: Terminal evaluation for analog input x 1: Simulation for analog input x		
<b>Index:</b>	[0] = AI0 (X132 3/4) [1] = AI1 (X132 10/11) [2] = NI 1000 0 (X202 80/82) [3] = NI 1000 1 (X202 81/82)		
<b>Dependency:</b>	The setpoint for the input voltage is specified via p0798. See also: p0798		
	<b>Note</b>		
	This parameter is not saved when data is backed up (p0971).		
	AI: Analog Input		
	X202: IO module terminal		

---

<b>p0798[0...3]</b>	<b>CU analog inputs simulation mode setpoint / CU AI sim setp</b>		
	<b>Access level:</b> 3	<b>Calculated:</b> -	<b>Data type:</b> FloatingPoint32
	<b>Can be changed:</b> T, U	<b>Scaling:</b> -	<b>Dynamic index:</b> -
	<b>Unit group:</b> -	<b>Unit selection:</b> -	<b>Function diagram:</b> -
	<b>Min:</b> -50.000	<b>Max:</b> 2000.000	<b>Factory setting:</b> 0.000
<b>Description:</b>	Sets the setpoint for the input value in the simulation mode of the analog inputs.		
<b>Index:</b>	[0] = AI0 (X132 3/4) [1] = AI1 (X132 10/11) [2] = NI 1000 0 (X202 80/82) [3] = NI 1000 1 (X202 81/82)		
<b>Dependency:</b>	The simulation of an analog input is selected using p0797. If AI x is parameterized as a voltage input (p0756), the setpoint is a voltage in V. If AI x is parameterized as a current input (p0756), the setpoint is a current in mA. See also: p0756, p0797		
	<b>Note</b>		
	This parameter is not saved when data is backed up (p0971).		
	AI: Analog Input		
	X202: IO module terminal		

---

---

<b>p0802</b>	<b>Data transfer: memory card as source/target / mem_card src/targ</b>		
	<b>Access level:</b> 3	<b>Calculated:</b> -	<b>Data type:</b> Integer16
	<b>Can be changed:</b> T	<b>Scaling:</b> -	<b>Dynamic index:</b> -
	<b>Unit group:</b> -	<b>Unit selection:</b> -	<b>Function diagram:</b> -
	<b>Min:</b> 0	<b>Max:</b> 100	<b>Factory setting:</b> 0
<b>Description:</b>	Sets the number for data transfer of a parameter backup from/to memory card. Transfer from memory card to device memory (p0804 = 1): - sets the source of parameter backup (e.g. p0802 = 48 --> PS048xxx.ACX is the source). Transfer from non-volatile device memory to memory card (p0804 = 2): - sets the target of parameter backup (e.g. p0802 = 23 --> PS023xxx.ACX is the target).		
<b>Dependency:</b>	See also: p0803, p0804		
	<b>Note</b> The volatile device memory is not influenced by data transfer.		

---

<b>p0803</b>	<b>Data transfer: device memory as source/target / Dev_mem src/targ</b>		
	<b>Access level:</b> 3	<b>Calculated:</b> -	<b>Data type:</b> Integer16
	<b>Can be changed:</b> T	<b>Scaling:</b> -	<b>Dynamic index:</b> -
	<b>Unit group:</b> -	<b>Unit selection:</b> -	<b>Function diagram:</b> -
	<b>Min:</b> 0	<b>Max:</b> 30	<b>Factory setting:</b> 0
<b>Description:</b>	Sets the number for data transfer of a parameter backup from/to the non-volatile device memory. Transfer from memory card to device memory (p0804 = 1): - sets the target of the parameter backup (e.g. p0803 = 10 --> PS010xxx.ACX is the target). Transfer from non-volatile device memory to memory card (p0804 = 2): - sets the source of the parameter backup (e.g. p0803 = 11 --> PS011xxx.ACX is the source).		
<b>Value:</b>	0: Source/target standard 10: Source/target with setting 10 11: Source/target with setting 11 12: Source/target with setting 12 30: Source/target with setting 30		
<b>Dependency:</b>	See also: p0802, p0804		
	<b>Note</b> The volatile device memory is not influenced by data transfer.		

---

<b>p0804</b>	<b>Data transfer start / Data transf start</b>		
	<b>Access level:</b> 3	<b>Calculated:</b> -	<b>Data type:</b> Integer16
	<b>Can be changed:</b> T	<b>Scaling:</b> -	<b>Dynamic index:</b> -
	<b>Unit group:</b> -	<b>Unit selection:</b> -	<b>Function diagram:</b> -
	<b>Min:</b> 0	<b>Max:</b> 1100	<b>Factory setting:</b> 0

- Description:** Sets the transfer direction and start of data transfer between the memory card and non-volatile device memory.
- Example 1:  
 The parameter backup is to be transferred from the non-volatile device memory to the memory card with setting 0. The parameter backup is to be stored on the memory card with setting 22.  
 p0802 = 22 (parameter backup stored on memory card as target with setting 22)  
 p0803 = 0 (parameter backup stored in device memory as source with setting 0)  
 p0804 = 2 (start data transfer from device memory to memory card)  
 --> PS000xxx.ACX is transferred from device memory to memory card and stored as PS022xxx.ACX.  
 --> the parameter backup PS022xxx.ACX on the memory card can be used for data backup.
- Example 2:  
 The parameter backup is to be transferred from the memory card to the non-volatile device memory with setting 22. The parameter backup is to be stored in the device memory as setting 10.  
 p0802 = 22 (parameter backup stored on memory card as source with setting 22)  
 p0803 = 10 (define parameter backup with setting 10 as target in the device memory)  
 p0804 = 1 (start data transfer from memory card to device memory)  
 --> PS022xxx.ACX is transferred from memory card to device memory and stored as PS010xxx.ACX.  
 --> this parameter backup can be loaded to the volatile device memory using p0010 = 30 and p0970 = 10.  
 --> to permanently save in the device memory and also on the memory card, this parameter backup should be saved using p0971 = 1.
- Example 3 (only supported for PROFIBUS/PROFINET):  
 The PROFIBUS or PROFINET device master data (GSD) should be transferred from the device memory to the memory card.  
 p0802 = (not relevant)  
 p0803 = (not relevant)  
 p0804 = 12 (start transferring the GSD files to the memory card)  
 --> The GSD files are transferred from the device memory to the memory card and stored in the /SIEMENS/SINAMICS/ DATA/CFG directory.
- Value:**
- 0: Inactive
  - 1: Memory card to device memory
  - 2: Device memory to memory card
  - 12: Device memory (GSD files) to memory card
  - 1001: File on memory card cannot be opened
  - 1002: File in device memory cannot be opened
  - 1003: Memory card not found
  - 1100: File cannot be transferred
- Recommendation:** When switching off/switching on, a possibly valid parameter backup is loaded to the memory card with setting 0. Therefore, we do not recommend parameter backup with setting 0 (p0803 = 0) in the non-volatile device memory.
- Dependency:** See also: p0802, p0803

**NOTICE**

The memory card must not be removed while data is being transferred.
--

7.3 Parameter list

**Note**

If a parameter backup with setting 0 is detected on the memory card when the Control Unit is switched on (PS000xxx.ACX), this is transferred automatically to the device memory.

When the memory card is inserted, a parameter backup with setting 0 (PS000xxx.ACX) is automatically written to the memory card when the parameters are saved in a non-volatile memory (e.g. by means of "Copy RAM to ROM").

Once the data has been successfully transferred, this parameter is automatically reset to 0. If an error occurs, the parameter is set to a value > 1000. Possible fault causes:

p0804 = 1001:

The parameter backup set in p0802 as the source on the memory card does not exist or there is not sufficient memory space available on the memory card.

p0804 = 1002:

The parameter backup set in p0803 as the source in the device memory does not exist or there is not sufficient memory space available in the device memory.

p0804 = 1003:

No memory card has been inserted.

**p0806**

**BI: Inhibit master control / PcCtrl inhibit**

**Access level:** 3

**Calculated:** -

**Data type:** Unsigned32 / Binary

**Can be changed:** T

**Scaling:** -

**Dynamic index:** -

**Unit group:** -

**Unit selection:** -

**Function diagram:** -

**Min:**

**Max:**

**Factory setting:**

-

-

0

**Description:**

Sets the signal source to block the master control.

**Dependency:**

See also: r0807

**Note**

The commissioning software (drive control panel) uses the master control, for example.

**r0807.0**

**BO: Master control active / PcCtrl active**

**Access level:** 3

**Calculated:** -

**Data type:** Unsigned8

**Can be changed:** -

**Scaling:** -

**Dynamic index:** -

**Unit group:** -

**Unit selection:** -

**Function diagram:** -

**Min:**

**Max:**

**Factory setting:**

-

-

-

**Description:**

Displays what has the master control.

The drive can be controlled via the BICO interconnection or from external (e.g. the commissioning software).

**Bit field:**

Bit	Signal name	1 signal	0 signal	FP
00	Master control active	Yes	No	3030

**Dependency:**

See also: p0806

**NOTICE**

The master control only influences control word 1 and speed setpoint 1. Other control word/setpoints can be transferred from another automation device.

**Note**

Bit 0 = 0: BICO interconnection active

Bit 0 = 1: Master control for PC/AOP

The commissioning software (drive control panel) uses the master control, for example.



<b>p0809[0...2]</b>	<b>Copy Command Data Set CDS / Copy CDS</b>		
	<b>Access level:</b> 2	<b>Calculated:</b> -	<b>Data type:</b> Unsigned8
	<b>Can be changed:</b> T	<b>Scaling:</b> -	<b>Dynamic index:</b> -
	<b>Unit group:</b> -	<b>Unit selection:</b> -	<b>Function diagram:</b> 8560
	<b>Min:</b> 0	<b>Max:</b> 3	<b>Factory setting:</b> 0
<b>Description:</b>	Copies one Command Data Set (CDS) into another.		
<b>Index:</b>	[0] = Source Command Data Set [1] = Target Command Data Set [2] = Start copying procedure		
<b>Dependency:</b>	See also: r3996		
	<b>NOTICE</b>		
	When the command data sets are copied, short-term communication interruptions may occur.		
	<b>Note</b>		
	Procedure:		
	1. In Index 0, enter which command data set should be copied.		
	2. In index 1, enter the command data set that is to be copied into.		
	3. Start copying: set index 2 from 0 to 1.		
	p0809[2] is automatically set to 0 when copying is completed.		
<b>p0810</b>	<b>BI: Command data set selection CDS bit 0 / CDS select., bit 0</b>		
	<b>Access level:</b> 2	<b>Calculated:</b> -	<b>Data type:</b> Unsigned32 / Binary
	<b>Can be changed:</b> T	<b>Scaling:</b> -	<b>Dynamic index:</b> -
	<b>Unit group:</b> -	<b>Unit selection:</b> -	<b>Function diagram:</b> 8560
	<b>Min:</b> -	<b>Max:</b> -	<b>Factory setting:</b> 722.4
<b>Description:</b>	Sets the signal source to select the Command Data Set bit 0 (CDS bit 0).		
<b>Dependency:</b>	See also: r0050, p0811, r0836		
	<b>NOTICE</b>		
	The parameter may be protected as a result of p0922 or p2079 and cannot be changed.		
	<b>Note</b>		
	The Command Data Set selected using the binector inputs is displayed in r0836.		
	The currently effective command data set is displayed in r0050.		
	A Command Data Set can be copied using p0809.		
<b>p0811</b>	<b>BI: Command data set selection CDS bit 1 / CDS select., bit 1</b>		
	<b>Access level:</b> 2	<b>Calculated:</b> -	<b>Data type:</b> Unsigned32 / Binary
	<b>Can be changed:</b> T	<b>Scaling:</b> -	<b>Dynamic index:</b> -
	<b>Unit group:</b> -	<b>Unit selection:</b> -	<b>Function diagram:</b> 8560
	<b>Min:</b> -	<b>Max:</b> -	<b>Factory setting:</b> 0
<b>Description:</b>	Sets the signal source to select the Command Data Set bit 1 (CDS bit 1).		
<b>Dependency:</b>	See also: r0050, p0810, r0836		
	<b>Note</b>		
	The Command Data Set selected using the binector inputs is displayed in r0836.		
	The currently effective command data set is displayed in r0050.		
	A Command Data Set can be copied using p0809.		

7.3 Parameter list

<b>p0819[0...2]</b>	<b>Copy Drive Data Set DDS / Copy DDS</b>		
	<b>Access level:</b> 2 <b>Can be changed:</b> C2(15) <b>Unit group:</b> - <b>Min:</b> 0	<b>Calculated:</b> - <b>Scaling:</b> - <b>Unit selection:</b> - <b>Max:</b> 3	<b>Data type:</b> Unsigned8 <b>Dynamic index:</b> - <b>Function diagram:</b> 8565 <b>Factory setting:</b> 0
<b>Description:</b>	Copies one Drive Data Set (DDS) into another.		
<b>Index:</b>	[0] = Source Drive Data Set [1] = Target Drive Data Set [2] = Start copying procedure		
<b>Dependency:</b>	See also: r3996		
<b>NOTICE</b> When the drive data sets are copied, short-term communication interruptions may occur.			
<b>Note</b> Procedure: 1. In Index 0, enter which drive data set is to be copied. 2. In index 1, enter the drive data set data that is to be copied into. 3. Start copying: set index 2 from 0 to 1. p0819[2] is automatically set to 0 when copying is completed.			
<b>p0820[0...n]</b>	<b>BI: Drive Data Set selection DDS bit 0 / DDS select., bit 0</b>		
	<b>Access level:</b> 3 <b>Can be changed:</b> T <b>Unit group:</b> - <b>Min:</b> -	<b>Calculated:</b> - <b>Scaling:</b> - <b>Unit selection:</b> - <b>Max:</b> -	<b>Data type:</b> Unsigned32 / Binary <b>Dynamic index:</b> CDS, p0170 <b>Function diagram:</b> 8565 <b>Factory setting:</b> 0
<b>Description:</b>	Sets the signal source to select the Drive Data Set, bit 0 (DDS, bit 0).		
<b>Dependency:</b>	See also: r0051, p0826, r0837		
<b>NOTICE</b> The parameter may be protected as a result of p0922 or p2079 and cannot be changed.			
<b>p0821[0...n]</b>	<b>BI: Drive Data Set selection DDS bit 1 / DDS select., bit 1</b>		
	<b>Access level:</b> 3 <b>Can be changed:</b> T <b>Unit group:</b> - <b>Min:</b> -	<b>Calculated:</b> - <b>Scaling:</b> - <b>Unit selection:</b> - <b>Max:</b> -	<b>Data type:</b> Unsigned32 / Binary <b>Dynamic index:</b> CDS, p0170 <b>Function diagram:</b> 8565, 8570 <b>Factory setting:</b> 0
<b>Description:</b>	Sets the signal source to select the Drive Data Set, bit 1 (DDS, bit 1).		
<b>Dependency:</b>	See also: r0051, r0837		
<b>NOTICE</b> The parameter may be protected as a result of p0922 or p2079 and cannot be changed.			
<b>p0826[0...n]</b>	<b>Motor changeover motor number / Mot_chng mot No.</b>		
	<b>Access level:</b> 3 <b>Can be changed:</b> T <b>Unit group:</b> - <b>Min:</b> 0	<b>Calculated:</b> - <b>Scaling:</b> - <b>Unit selection:</b> - <b>Max:</b> 3	<b>Data type:</b> Unsigned16 <b>Dynamic index:</b> MDS, p0130 <b>Function diagram:</b> - <b>Factory setting:</b> 0

**Description:** Sets the freely assignable motor number for the drive data set changeover.  
If the same motor is driven by different drive data sets, the same motor number must also be entered in these data sets.  
If the motor is also switched with the drive data set, different motor numbers must be used. In this case, the data set can only be switched when the pulse inhibit is set.

**Note**

If the motor numbers are identical, the same thermal motor model is used for calculation after data set changeover. If different motor numbers are used, different models are also used for calculating (the inactive motor cools down in each case).

For the same motor number, the correction values of the Rs, Lh or kT adaptation are applied for the data set changeover (refer to r1782, r1787, r1797).

**r0835.2...8****CO/BO: Data set changeover status word / DDS\_ZSW****Access level:** 2**Calculated:** -**Data type:** Unsigned16**Can be changed:** -**Scaling:** -**Dynamic index:** -**Unit group:** -**Unit selection:** -**Function diagram:** 8575**Min:****Max:****Factory setting:**

-

-

-

**Description:**

Displays the status word for the drive data set changeover.

**Bit field:**

Bit	Signal name	1 signal	0 signal	FP
02	Internal parameter calculation active	Yes	No	-
04	Armature short circuit active	Yes	No	-
05	Identification running	Yes	No	-
07	Rotating measurement running	Yes	No	-
08	Motor data identification running	Yes	No	-

**Note**

For bit 02:

A data set changeover is delayed by the time required for the internal parameter calculation.

For bit 04:

A data set changeover is only carried out when the armature short circuit is not activated.

For bit 05:

A data set changeover is only carried out when pole position identification is not running.

For bit 07:

A data set changeover is only carried out when rotating measurement is not running.

For bit 08:

A data set changeover is only carried out when motor data identification is not running.

**r0836.0...1****CO/BO: Command Data Set CDS selected / CDS selected****Access level:** 3**Calculated:** -**Data type:** Unsigned8**Can be changed:** -**Scaling:** -**Dynamic index:** -**Unit group:** -**Unit selection:** -**Function diagram:** 8560**Min:****Max:****Factory setting:**

-

-

-

**Description:**

Displays the command data set (CDS) selected via the binector input.

**Bit field:**

Bit	Signal name	1 signal	0 signal	FP
00	CDS selection bit 0	ON	OFF	-
01	CDS selection bit 1	ON	OFF	-

**Dependency:**

See also: r0050, p0810, p0811

**Note**

Command data sets are selected via binector input p0810 and following.

The currently effective command data set is displayed in r0050.

7.3 Parameter list

<b>r0837.0...1</b>	<b>CO/BO: Drive Data Set DDS selected / DDS selected</b>			
	<b>Access level:</b> 3	<b>Calculated:</b> -	<b>Data type:</b> Unsigned8	
	<b>Can be changed:</b> -	<b>Scaling:</b> -	<b>Dynamic index:</b> -	
	<b>Unit group:</b> -	<b>Unit selection:</b> -	<b>Function diagram:</b> 8565	
	<b>Min:</b> -	<b>Max:</b> -	<b>Factory setting:</b> -	
<b>Description:</b>	Displays the drive data set (DDS) selected via the binector input.			
<b>Bit field:</b>	<b>Bit</b>	<b>Signal name</b>	<b>1 signal</b>	<b>0 signal</b>
	00	DDS selection bit 0	ON	OFF
	01	DDS selection bit 1	ON	OFF
<b>Dependency:</b>	See also: r0051, p0820, p0821			
	<b>Note</b>			
	Drive data sets are selected via binector input p0820 and following. The currently effective drive data set is displayed in r0051. If there is only one data set, then a value of 0 is displayed in this parameter and not the selection via binector inputs.			

<b>p0840[0...n]</b>	<b>BI: ON / OFF (OFF1) / ON / OFF (OFF1)</b>			
	<b>Access level:</b> 3	<b>Calculated:</b> -	<b>Data type:</b> Unsigned32 / Binary	
	<b>Can be changed:</b> T	<b>Scaling:</b> -	<b>Dynamic index:</b> CDS, p0170	
	<b>Unit group:</b> -	<b>Unit selection:</b> -	<b>Function diagram:</b> 2501, 2512	
	<b>Min:</b> -	<b>Max:</b> -	<b>Factory setting:</b> [0] 2090.0 [1] 0 [2] 0 [3] 0	
<b>Description:</b>	Sets the signal source for the command "ON/OFF (OFF1)". For the PROFIdrive profile, this command corresponds to control word 1 bit 0 (STW1.0).			
<b>Recommendation:</b>	When the setting for this binector input is changed, the motor can only be switched on by means of an appropriate signal change of the source.			
<b>Dependency:</b>	See also: p1055, p1056			

<b>CAUTION</b>
When "master control from PC" is activated, this binector input is ineffective.

<b>NOTICE</b>
For binector input p0840 = 0 signal, the motor can be moved, jogging using binector input p1055 or p1056. The command "ON/OFF (OFF1)" can be issued using binector input p0840 or p1055/p1056. For binector input p0840 = 0 signal, the switching on inhibited is acknowledged. Only the signal source that originally switched on can also switch off again. The parameter may be protected as a result of p0922 or p2079 and cannot be changed.

**Note**

For drives with closed-loop speed control (p1300 = 20), the following applies:

- BI: p0840 = 0 signal: OFF1 (braking with the ramp-function generator, then pulse suppression and switching on inhibited)

For drives with closed-loop torque control (p1300 = 22), the following applies:

- BI: p0840 = 0 signal: immediate pulse suppression

For drives with closed-loop torque control (activated using p1501), the following applies:

- BI: p0840 = 0 signal: No dedicated braking response, but pulse cancelation when standstill is detected (p1226, p1227)

For drives with closed-loop speed/torque control, the following applies:

- BI: p0840 = 0/1 signal: ON (pulses can be enabled)

<b>p0844[0...n]</b>	<b>BI: No coast-down / coast-down (OFF2) signal source 1 / OFF2 S_src 1</b>		
	<b>Access level:</b> 3	<b>Calculated:</b> -	<b>Data type:</b> Unsigned32 / Binary
	<b>Can be changed:</b> T	<b>Scaling:</b> -	<b>Dynamic index:</b> CDS, p0170
	<b>Unit group:</b> -	<b>Unit selection:</b> -	<b>Function diagram:</b> 2501, 8720, 8820, 8920
	<b>Min:</b> -	<b>Max:</b> -	<b>Factory setting:</b> [0] 2090.1 [1] 1 [2] 2090.1 [3] 2090.1

**Description:** Sets the first signal source for the command "No coast down/coast down (OFF2)".  
The following signals are AND'ed:  
- BI: p0844 "No coast-down / coast-down (OFF2) signal source 1"  
- BI: p0845 "No coast-down / coast-down (OFF2) signal source 2"  
For the PROFIdrive profile, the result of the AND logic operation corresponds to control word 1 bit 1 (STW1.1).  
BI: p0844 = 0 signal or BI: p0845 = 0 signal  
- OFF2 (immediate pulse suppression and switching on inhibited)  
BI: p0844 = 1 signal and BI: p0845 = 1 signal  
- no OFF2 (enable is possible)

**⚠ CAUTION**

When "master control from PC" is activated, this binector input is ineffective.

**NOTICE**

The parameter may be protected as a result of p0922 or p2079 and cannot be changed.

<b>p0845[0...n]</b>	<b>BI: No coast-down / coast-down (OFF2) signal source 2 / OFF2 S_src 2</b>		
	<b>Access level:</b> 3	<b>Calculated:</b> -	<b>Data type:</b> Unsigned32 / Binary
	<b>Can be changed:</b> T	<b>Scaling:</b> -	<b>Dynamic index:</b> CDS, p0170
	<b>Unit group:</b> -	<b>Unit selection:</b> -	<b>Function diagram:</b> 2501, 8720, 8820, 8920
	<b>Min:</b> -	<b>Max:</b> -	<b>Factory setting:</b> 1

**Description:** Sets the second signal source for the command "No coast down/coast down (OFF2)".  
The following signals are AND'ed:  
- BI: p0844 "No coast-down / coast-down (OFF2) signal source 1"  
- BI: p0845 "No coast-down / coast-down (OFF2) signal source 2"  
For the PROFIdrive profile, the result of the AND logic operation corresponds to control word 1 bit 1 (STW1.1).  
BI: p0844 = 0 signal or BI: p0845 = 0 signal  
- OFF2 (immediate pulse suppression and switching on inhibited)  
BI: p0844 = 1 signal and BI: p0845 = 1 signal  
- no OFF2 (enable is possible)

**⚠ CAUTION**

When "master control from PC" is activated, this binector input is effective.

7.3 Parameter list

<b>p0845[0...n]</b> CUG120X_PN (PM330)	<b>BI: No coast-down / coast-down (OFF2) signal source 2 / OFF2 S_src 2</b>		
	<b>Access level:</b> 3	<b>Calculated:</b> -	<b>Data type:</b> Unsigned32 / Binary
	<b>Can be changed:</b> T	<b>Scaling:</b> -	<b>Dynamic index:</b> CDS, p0170
	<b>Unit group:</b> -	<b>Unit selection:</b> -	<b>Function diagram:</b> 2501, 8720, 8820, 8920
	<b>Min:</b> -	<b>Max:</b> -	<b>Factory setting:</b> 4022.3
<b>Description:</b>	Sets the second signal source for the command "No coast down/coast down (OFF2)". The following signals are AND'ed: - BI: p0844 "No coast-down / coast-down (OFF2) signal source 1" - BI: p0845 "No coast-down / coast-down (OFF2) signal source 2" For the PROFIdrive profile, the result of the AND logic operation corresponds to control word 1 bit 1 (STW1.1). BI: p0844 = 0 signal or BI: p0845 = 0 signal - OFF2 (immediate pulse suppression and switching on inhibited) BI: p0844 = 1 signal and BI: p0845 = 1 signal - no OFF2 (enable is possible)		

<b>CAUTION</b>
When "master control from PC" is activated, this binector input is effective.

<b>p0848[0...n]</b>	<b>BI: No Quick Stop / Quick Stop (OFF3) signal source 1 / OFF3 S_src 1</b>		
	<b>Access level:</b> 3	<b>Calculated:</b> -	<b>Data type:</b> Unsigned32 / Binary
	<b>Can be changed:</b> T	<b>Scaling:</b> -	<b>Dynamic index:</b> CDS, p0170
	<b>Unit group:</b> -	<b>Unit selection:</b> -	<b>Function diagram:</b> 2501
	<b>Min:</b> -	<b>Max:</b> -	<b>Factory setting:</b> [0] 2090.2 [1] 1 [2] 2090.2 [3] 2090.2

**Description:** Sets the first signal source for the command "No quick stop/quick stop (OFF3)".  
The following signals are AND'ed:  
- BI: p0848 "No quick stop / quick stop (OFF3) signal source 1"  
- BI: p0849 "No quick stop / quick stop (OFF3) signal source 2"  
For the PROFIdrive profile, the result of the AND logic operation corresponds to control word 1 bit 2 (STW1.2).  
BI: p0848 = 0 signal or BI: p0849 = 0 signal  
- OFF3 (braking along the OFF3 ramp (p1135), then pulse suppression and switching on inhibited)  
BI: p0848 = 1 signal and BI: p0849 = 1 signal  
- no OFF3 (enable is possible)

<b>CAUTION</b>
When "master control from PC" is activated, this binector input is ineffective.

<b>NOTICE</b>
The parameter may be protected as a result of p0922 or p2079 and cannot be changed.

**Note**  
For drives with closed-loop torque control (activated using p1501), the following applies:  
BI: p0848 = 0 signal:  
- no dedicated braking response, but pulse suppression when standstill is detected (p1226, p1227).

<b>p0849[0...n]</b>	<b>BI: No Quick Stop / Quick Stop (OFF3) signal source 2 / OFF3 S_src 2</b>		
	<b>Access level:</b> 3	<b>Calculated:</b> -	<b>Data type:</b> Unsigned32 / Binary
	<b>Can be changed:</b> T	<b>Scaling:</b> -	<b>Dynamic index:</b> CDS, p0170
	<b>Unit group:</b> -	<b>Unit selection:</b> -	<b>Function diagram:</b> 2501
	<b>Min:</b>	<b>Max:</b>	<b>Factory setting:</b>
	-	-	1

**Description:** Sets the second signal source for the command "No quick stop/quick stop (OFF3)".  
The following signals are AND'ed:  
- BI: p0848 "No quick stop / quick stop (OFF3) signal source 1"  
- BI: p0849 "No quick stop / quick stop (OFF3) signal source 2"  
For the PROFIdrive profile, the result of the AND logic operation corresponds to control word 1 bit 2 (STW1.2).  
BI: p0848 = 0 signal or BI: p0849 = 0 signal  
- OFF3 (braking along the OFF3 ramp (p1135), then pulse suppression and switching on inhibited)  
BI: p0848 = 1 signal and BI: p0849 = 1 signal  
- no OFF3 (enable is possible)

**⚠ CAUTION**

When "master control from PC" is activated, this binector input is effective.

<b>p0849[0...n]</b>	<b>BI: No Quick Stop / Quick Stop (OFF3) signal source 2 / OFF3 S_src 2</b>		
CUG120X_PN (PM330)	<b>Access level:</b> 3	<b>Calculated:</b> -	<b>Data type:</b> Unsigned32 / Binary
	<b>Can be changed:</b> T	<b>Scaling:</b> -	<b>Dynamic index:</b> CDS, p0170
	<b>Unit group:</b> -	<b>Unit selection:</b> -	<b>Function diagram:</b> 2501
	<b>Min:</b>	<b>Max:</b>	<b>Factory setting:</b>
	-	-	4022.2

**Description:** Sets the second signal source for the command "No quick stop/quick stop (OFF3)".  
The following signals are AND'ed:  
- BI: p0848 "No quick stop / quick stop (OFF3) signal source 1"  
- BI: p0849 "No quick stop / quick stop (OFF3) signal source 2"  
For the PROFIdrive profile, the result of the AND logic operation corresponds to control word 1 bit 2 (STW1.2).  
BI: p0848 = 0 signal or BI: p0849 = 0 signal  
- OFF3 (braking along the OFF3 ramp (p1135), then pulse suppression and switching on inhibited)  
BI: p0848 = 1 signal and BI: p0849 = 1 signal  
- no OFF3 (enable is possible)

**⚠ CAUTION**

When "master control from PC" is activated, this binector input is effective.

<b>p0852[0...n]</b>	<b>BI: Enable operation/inhibit operation / Enable operation</b>		
	<b>Access level:</b> 3	<b>Calculated:</b> -	<b>Data type:</b> Unsigned32 / Binary
	<b>Can be changed:</b> T	<b>Scaling:</b> -	<b>Dynamic index:</b> CDS, p0170
	<b>Unit group:</b> -	<b>Unit selection:</b> -	<b>Function diagram:</b> 2501
	<b>Min:</b>	<b>Max:</b>	<b>Factory setting:</b>
	-	-	[0] 2090.3
			[1] 1
			[2] 2090.3
			[3] 2090.3

7.3 Parameter list

**Description:** Sets the signal source for the command "enable operation/inhibit operation".  
 For the PROFIdrive profile, this command corresponds to control word 1 bit 3 (STW1.3).  
 BI: p0852 = 0 signal  
 Inhibit operation (suppress pulses).  
 BI: p0852 = 1 signal  
 Enable operation (pulses can be enabled).

<b>CAUTION</b>
When "master control from PC" is activated, this binector input is ineffective.
<b>NOTICE</b>
The parameter may be protected as a result of p0922 or p2079 and cannot be changed.

**p0854[0...n]**      **BI: Control by PLC/no control by PLC / Master ctrl by PLC**

<b>Access level:</b> 3	<b>Calculated:</b> -	<b>Data type:</b> Unsigned32 / Binary
<b>Can be changed:</b> T	<b>Scaling:</b> -	<b>Dynamic index:</b> CDS, p0170
<b>Unit group:</b> -	<b>Unit selection:</b> -	<b>Function diagram:</b> 2501
<b>Min:</b>	<b>Max:</b>	<b>Factory setting:</b>
-	-	[0] 2090.10
		[1] 1
		[2] 2090.10
		[3] 2090.10

**Description:** Sets the signal source for the command "control by PLC/no control by PLC".  
 For the PROFIdrive profile, this command corresponds to control word 1 bit 10 (STW1.10).  
 BI: p0854 = 0 signal  
 No control by PLC  
 BI: p0854 = 1 signal  
 Master control by PLC.

<b>CAUTION</b>
When "master control from PC" is activated, this binector input is ineffective.
<b>NOTICE</b>
The parameter may be protected as a result of p0922 or p2079 and cannot be changed.

**Note**  
 This bit is used to initiate a response for the drives when the control fails (F07220). If there is no control available, then binector input p0854 should be set to 1.  
 If a control is available, then STW1.10 must be set to 1 (PZD1) so that the received data is updated. This applies regardless of the setting in p0854 and even in the case of free telegram configuration (p0922 = 999).

**p0857**      **Power unit monitoring time / PU t\_monit**

<b>Access level:</b> 3	<b>Calculated:</b> -	<b>Data type:</b> FloatingPoint32
<b>Can be changed:</b> T	<b>Scaling:</b> -	<b>Dynamic index:</b> -
<b>Unit group:</b> -	<b>Unit selection:</b> -	<b>Function diagram:</b> 8760, 8864, 8964
<b>Min:</b>	<b>Max:</b>	<b>Factory setting:</b>
100.0 [ms]	60000.0 [ms]	10000.0 [ms]

**Description:** Sets the monitoring time for the power unit.  
 The monitoring time is started after an 0/1 edge of the ON/OFF1 command. If the power unit does not return a READY signal within the monitoring time, fault F07802 is output.

**Dependency:** See also: F07802, F07840, F30027



<b>NOTICE</b>
The maximum time to precharge the DC link is monitored in the power unit and cannot be changed. The maximum precharging duration depends on the power unit. The monitoring time for the precharging is started after the ON command (BI: p0840 = 0/1 signal). Fault F30027 is output when the maximum precharging duration is exceeded.

**Note**

The factory setting for p0857 depends on the power unit.

The monitoring time for the ready signal of the power unit includes the time to precharge the DC link and, if relevant, the de-bounce time of the contactors.

If an excessively low value is entered into p0857, then after enable, this results in the corresponding fault.

<b>p0860</b>	<b>BI: Line contactor feedback signal / Line contact feedb</b>		
	<b>Access level:</b> 3	<b>Calculated:</b> -	<b>Data type:</b> Unsigned32 / Binary
	<b>Can be changed:</b> T	<b>Scaling:</b> -	<b>Dynamic index:</b> -
	<b>Unit group:</b> -	<b>Unit selection:</b> -	<b>Function diagram:</b> 2634
	<b>Min:</b>	<b>Max:</b>	<b>Factory setting:</b>
	-	-	863.1
<b>Description:</b>	Sets the signal source for the feedback signal from the line contactor.		
<b>Recommendation:</b>	When the monitoring is activated (BI: p0860 not equal to r0863.1), then to control the line contactor, signal BO: r0863.1 of its own drive object should be used.		
<b>Dependency:</b>	See also: p0861, r0863 See also: F07300		

<b>NOTICE</b>
The line contactor monitoring is deactivated if the control signal of the particular drive object is set as the signal source for the feedback signal of the line contactor (BI: p0860 = r0863.1).

**Note**

The state of the line contactor is monitored depending on signal BO: r0863.1.

When the monitoring is activated (BI: p0860 not equal to r0863.1), fault F07300 is then also output if the contactor is closed before it is controlled using r0863.1.

<b>p0861</b>	<b>Line contactor monitoring time / LineContact t_mon</b>		
	<b>Access level:</b> 3	<b>Calculated:</b> -	<b>Data type:</b> FloatingPoint32
	<b>Can be changed:</b> T	<b>Scaling:</b> -	<b>Dynamic index:</b> -
	<b>Unit group:</b> -	<b>Unit selection:</b> -	<b>Function diagram:</b> 2634
	<b>Min:</b>	<b>Max:</b>	<b>Factory setting:</b>
	0 [ms]	5000 [ms]	100 [ms]
<b>Description:</b>	Sets the monitoring time of the line contactor. This time starts each time that the line contactor switches (r0863.1). If a feedback signal is not received from the line contactor within the time, a message is output.		
<b>Dependency:</b>	See also: p0860, r0863 See also: F07300		

**Note**

The monitoring function is disabled for the factory setting of p0860.

<b>r0863.0...1</b>	<b>CO/BO: Drive coupling status word/control word / CoupleZSW/STW</b>		
	<b>Access level:</b> 3	<b>Calculated:</b> -	<b>Data type:</b> Unsigned16
	<b>Can be changed:</b> -	<b>Scaling:</b> -	<b>Dynamic index:</b> -
	<b>Unit group:</b> -	<b>Unit selection:</b> -	<b>Function diagram:</b> -
	<b>Min:</b>	<b>Max:</b>	<b>Factory setting:</b>
	-	-	-

Parameters

7.3 Parameter list

**Description:** Display and BICO output for the status word and control word of the drive coupling.

Bit field:	Bit	Signal name	1 signal	0 signal	FP
	00	Closed-loop control operation	Yes	No	-
	01	Energize contactor	Yes	No	2634

**Note**

For bit 01:  
Bit 1 is used to control an external line contactor.

**p0867 Power unit main contactor holding time after OFF1 / PU t\_MC after OFF1**

<b>Access level:</b> 3	<b>Calculated:</b> -	<b>Data type:</b> FloatingPoint32
<b>Can be changed:</b> T	<b>Scaling:</b> -	<b>Dynamic index:</b> -
<b>Unit group:</b> -	<b>Unit selection:</b> -	<b>Function diagram:</b> -
<b>Min:</b> 0.0 [ms]	<b>Max:</b> 500.0 [ms]	<b>Factory setting:</b> 50.0 [ms]

**Description:** Sets the main contactor holding time after OFF1

**Dependency:** See also: p0869

**Note**

After withdrawing the OFF1 enable (source of p0840), the main contactor is opened after the main contactor holding time has elapsed.  
For p0869 = 1 (keep main contactor closed for STO), after withdrawing STO, the switching on inhibited must be acknowledged via the source of p0840 = 0 (OFF1) – and before the main contactor holding time expires, should go back to 1, otherwise the main contactor will open.  
When operating a drive connected to SINUMERIK, which only closes the main contactor with the OFF1 command (blocksize, chassis), p0867 should be set as a minimum to 50 ms.

**p0868 Power unit thyristor rectifier wait time / PU thy\_rect t**

CUG120X\_PN  
(PM330)

<b>Access level:</b> 3	<b>Calculated:</b> -	<b>Data type:</b> FloatingPoint32
<b>Can be changed:</b> T	<b>Scaling:</b> -	<b>Dynamic index:</b> -
<b>Unit group:</b> -	<b>Unit selection:</b> -	<b>Function diagram:</b> -
<b>Min:</b> 0 [ms]	<b>Max:</b> 65000 [ms]	<b>Factory setting:</b> 0 [ms]

**Description:** Sets the debounce time for the DC circuit breaker for power units in the "chassis" format.

**Dependency:** The parameter is only active for PM330 power units.

**Note**

The following applies if p0868 = 65000 ms:  
The debounce time defined internally in the power unit's EEPROM is implemented.

**p0869 Sequence control configuration / Seq\_ctrl config**

<b>Access level:</b> 3	<b>Calculated:</b> -	<b>Data type:</b> Unsigned16
<b>Can be changed:</b> T	<b>Scaling:</b> -	<b>Dynamic index:</b> -
<b>Unit group:</b> -	<b>Unit selection:</b> -	<b>Function diagram:</b> -
<b>Min:</b> -	<b>Max:</b> -	<b>Factory setting:</b> 0000 bin

**Description:** Sets the configuration for the sequence control.

Bit field:	Bit	Signal name	1 signal	0 signal	FP
	00	Keep main contactor closed for STO	Yes	No	-

**Dependency:** See also: p0867

**Note**

For bit 00:

After withdrawing the OFF1 enable (source of p0840), the main contactor is opened after the main contactor holding time has elapsed.

For p0869.0 = 1, after withdrawing STO, the switching on inhibited must be acknowledged via the source of p0840 = 0 (OFF1) – and before the main contactor holding time expires (p0867), should go back to 1, otherwise the main contactor will open.

**p0870****BI: Close main contactor / Close main cont****Access level:** 2**Calculated:** -**Data type:** Unsigned32 / Binary**Can be changed:** T**Scaling:** -**Dynamic index:** -**Unit group:** -**Unit selection:** -**Function diagram:** -**Min:****Max:****Factory setting:**

-

-

0

**Description:**

Sets the signal source to close the main contactor.

**Note**

The main contactor is also closed when the converter is switched on after issuing the necessary enable signals. A binector input p0870 = 1 signal prevents the main contactor from being opened when enable signals are withdrawn.

**r0898.0...10****CO/BO: Control word sequence control / STW seq\_ctrl****Access level:** 2**Calculated:** -**Data type:** Unsigned16**Can be changed:** -**Scaling:** -**Dynamic index:** -**Unit group:** -**Unit selection:** -**Function diagram:** 2501**Min:****Max:****Factory setting:**

-

-

-

**Description:**

Display and connector output for the control word of the sequence control.

**Bit field:**

Bit	Signal name	1 signal	0 signal	FP
00	ON/OFF1	Yes	No	-
01	OC / OFF2	Yes	No	-
02	OC / OFF3	Yes	No	-
03	Enable operation	Yes	No	-
04	Enable ramp-function generator	Yes	No	-
05	Continue ramp-function generator	Yes	No	-
06	Enable speed setpoint	Yes	No	-
08	Jog 1	Yes	No	3001
09	Jog 2	Yes	No	3001
10	Master control by PLC	Yes	No	-

**Note**

OC: Operating condition

**r0899.0...11****CO/BO: Status word sequence control / ZSW seq\_ctrl****Access level:** 2**Calculated:** -**Data type:** Unsigned16**Can be changed:** -**Scaling:** -**Dynamic index:** -**Unit group:** -**Unit selection:** -**Function diagram:** 2503**Min:****Max:****Factory setting:**

-

-

-

**Description:**

Display and BICO output for the status word of the sequence control.

**Bit field:**

Bit	Signal name	1 signal	0 signal	FP
00	Ready for switching on	Yes	No	-

7.3 Parameter list

01	Ready	Yes	No	-
02	Operation enabled	Yes	No	-
03	Jog active	Yes	No	-
04	No coasting active	OFF2 inactive	OFF2 active	-
05	No Quick Stop active	OFF3 inactive	OFF3 active	-
06	Switching on inhibited active	Yes	No	-
07	Drive ready	Yes	No	-
08	Controller enable	Yes	No	-
09	Control request	Yes	No	-
11	Pulses enabled	Yes	No	-

**Note**

For bits 00, 01, 02, 04, 05, 06, 09:  
For PROFIdrive, these signals are used for status word 1.

**p0922**

**PROFIdrive PZD telegram selection / PZD telegr\_sel**

<b>Access level:</b> 1	<b>Calculated:</b> -	<b>Data type:</b> Unsigned16
<b>Can be changed:</b> C2(1), T	<b>Scaling:</b> -	<b>Dynamic index:</b> -
<b>Unit group:</b> -	<b>Unit selection:</b> -	<b>Function diagram:</b> 2401, 2420
<b>Min:</b> 1	<b>Max:</b> 999	<b>Factory setting:</b> 1

**Description:**

Sets the send and receive telegram.

**Value:**

- 1: Standard telegram 1, PZD-2/2
- 20: Standard telegram 20, PZD-2/6
- 350: SIEMENS telegram 350, PZD-4/4
- 352: SIEMENS telegram 352, PZD-6/6
- 353: SIEMENS telegram 353, PZD-2/2, PKW-4/4
- 354: SIEMENS telegram 354, PZD-6/6, PKW-4/4
- 999: Free telegram configuration with BICO

**Dependency:**

See also: p2038  
See also: F01505

**Note**

For p0922 = 100 ... 199, p2038 is automatically set to 1 and p2038 can no longer be changed. This means that for these telegrams, the "SIMODRIVE 611 universal" interface mode is set and cannot be changed.  
If a value is not equal to 999, a telegram is set and the automatically set interconnections in the telegram are inhibited. The inhibited interconnections can only be changed again after setting value 999.

**r0944**

**CO: Counter for fault buffer changes / Fault buff change**

<b>Access level:</b> 3	<b>Calculated:</b> -	<b>Data type:</b> Unsigned16
<b>Can be changed:</b> -	<b>Scaling:</b> -	<b>Dynamic index:</b> -
<b>Unit group:</b> -	<b>Unit selection:</b> -	<b>Function diagram:</b> 8060
<b>Min:</b> -	<b>Max:</b> -	<b>Factory setting:</b> -

**Description:**

Display and connector output for the counter for changes of the fault buffer.  
This counter is incremented every time the fault buffer changes.

**Recommendation:**

Used to check whether the fault buffer has been read out consistently.

**Dependency:**

See also: r0945, r0947, r0948, r0949, r2109

<b>r0945[0...63]</b>	<b>Fault code / Fault code</b>		
	<b>Access level:</b> 3	<b>Calculated:</b> -	<b>Data type:</b> Unsigned16
	<b>Can be changed:</b> -	<b>Scaling:</b> -	<b>Dynamic index:</b> -
	<b>Unit group:</b> -	<b>Unit selection:</b> -	<b>Function diagram:</b> 8050, 8060
	<b>Min:</b>	<b>Max:</b>	<b>Factory setting:</b>
	-	-	-
<b>Description:</b>	Displays the numbers of faults that have occurred.		
<b>Dependency:</b>	See also: r0947, r0948, r0949, r2109, r2130, r2133, r2136, r3120, r3122		
<b>NOTICE</b>			
The properties of the fault buffer should be taken from the corresponding product documentation.			
<b>Note</b>			
The buffer parameters are cyclically updated in the background (refer to status signal in r2139).			
Fault buffer structure (general principle):			
r0945[0], r0949[0], r0948[0], r2109[0] --> actual fault case, fault 1			
...			
r0945[7], r0949[7], r0948[7], r2109[7] --> actual fault case, fault 8			
r0945[8], r0949[8], r0948[8], r2109[8] --> 1st acknowledged fault case, fault 1			
...			
r0945[15], r0949[15], r0948[15], r2109[15] --> 1st acknowledged fault case, fault 8			
...			
r0945[56], r0949[56], r0948[56], r2109[56] --> 7th acknowledged fault case, fault 1			
...			
r0945[63], r0949[63], r0948[63], r2109[63] --> 7th acknowledged fault case, fault 8			

<b>r0946[0...65534]</b>	<b>Fault code list / Fault code list</b>		
	<b>Access level:</b> 3	<b>Calculated:</b> -	<b>Data type:</b> Unsigned16
	<b>Can be changed:</b> -	<b>Scaling:</b> -	<b>Dynamic index:</b> -
	<b>Unit group:</b> -	<b>Unit selection:</b> -	<b>Function diagram:</b> 8060
	<b>Min:</b>	<b>Max:</b>	<b>Factory setting:</b>
	-	-	-
<b>Description:</b>	Lists the fault codes stored in the drive unit. The indices can only be accessed with a valid fault code.		
<b>Dependency:</b>	The parameter assigned to the fault code is entered in r0951 under the same index.		

<b>r0947[0...63]</b>	<b>Fault number / Fault number</b>		
	<b>Access level:</b> 2	<b>Calculated:</b> -	<b>Data type:</b> Unsigned16
	<b>Can be changed:</b> -	<b>Scaling:</b> -	<b>Dynamic index:</b> -
	<b>Unit group:</b> -	<b>Unit selection:</b> -	<b>Function diagram:</b> 8050, 8060
	<b>Min:</b>	<b>Max:</b>	<b>Factory setting:</b>
	-	-	-
<b>Description:</b>	This parameter is identical to r0945.		

<b>r0948[0...63]</b>	<b>Fault time received in milliseconds / t_fault recv ms</b>		
	<b>Access level:</b> 3	<b>Calculated:</b> -	<b>Data type:</b> Unsigned32
	<b>Can be changed:</b> -	<b>Scaling:</b> -	<b>Dynamic index:</b> -
	<b>Unit group:</b> -	<b>Unit selection:</b> -	<b>Function diagram:</b> 8050, 8060
	<b>Min:</b>	<b>Max:</b>	<b>Factory setting:</b>
	- [ms]	- [ms]	- [ms]
<b>Description:</b>	Displays the system runtime in milliseconds when the fault occurred.		
<b>Dependency:</b>	See also: r0945, r0947, r0949, r2109, r2130, r2133, r2136, p8400		

7.3 Parameter list

<b>NOTICE</b>
The time comprises r2130 (days) and r0948 (milliseconds).

**Note**

The buffer parameters are cyclically updated in the background (refer to status signal in r2139).  
 The structure of the fault buffer and the assignment of the indices is shown in r0945.  
 When the parameter is read via PROFIdrive, the TimeDifference data type applies.

<b>r0949[0...63]</b>	<b>Fault value / Fault value</b>		
	<b>Access level:</b> 3	<b>Calculated:</b> -	<b>Data type:</b> Integer32
	<b>Can be changed:</b> -	<b>Scaling:</b> -	<b>Dynamic index:</b> -
	<b>Unit group:</b> -	<b>Unit selection:</b> -	<b>Function diagram:</b> 8050, 8060
	<b>Min:</b> -	<b>Max:</b> -	<b>Factory setting:</b> -
<b>Description:</b>	Displays additional information about the fault that occurred (as integer number).		
<b>Dependency:</b>	See also: r0945, r0947, r0948, r2109, r2130, r2133, r2136, r3120, r3122		

**Note**

The buffer parameters are cyclically updated in the background (refer to status signal in r2139).  
 The structure of the fault buffer and the assignment of the indices is shown in r0945.

<b>p0952</b>	<b>Fault cases counter / Fault cases qty</b>		
	<b>Access level:</b> 3	<b>Calculated:</b> -	<b>Data type:</b> Unsigned16
	<b>Can be changed:</b> T, U	<b>Scaling:</b> -	<b>Dynamic index:</b> -
	<b>Unit group:</b> -	<b>Unit selection:</b> -	<b>Function diagram:</b> 6700, 8060
	<b>Min:</b> 0	<b>Max:</b> 65535	<b>Factory setting:</b> 0
<b>Description:</b>	Number of fault situations that have occurred since the last reset.		
<b>Dependency:</b>	The fault buffer is deleted (cleared) by setting p0952 to 0. See also: r0945, r0947, r0948, r0949, r2109, r2130, r2133, r2136		

<b>r0964[0...6]</b>	<b>Device identification / Device ident</b>		
	<b>Access level:</b> 3	<b>Calculated:</b> -	<b>Data type:</b> Unsigned16
	<b>Can be changed:</b> -	<b>Scaling:</b> -	<b>Dynamic index:</b> -
	<b>Unit group:</b> -	<b>Unit selection:</b> -	<b>Function diagram:</b> -
	<b>Min:</b> -	<b>Max:</b> -	<b>Factory setting:</b> -
<b>Description:</b>	Displays the device identification.		
<b>Index:</b>	[0] = Company (Siemens = 42) [1] = Device type [2] = Firmware version [3] = Firmware date (year) [4] = Firmware date (day/month) [5] = Number of drive objects [6] = Firmware patch/hot fix		

**Note**

Example:

r0964[0] = 42 --&gt; SIEMENS

r0964[1] = device type, see below

r0964[2] = 403 --&gt; first part of the firmware version V04.03 (for second part, refer to index 6)

r0964[3] = 2010 --&gt; year 2010

r0964[4] = 1705 --&gt; 17th of May

r0964[5] = 2 --&gt; 2 drive objects

r0964[6] = 200 --&gt; second part, firmware version (complete version: V04.03.02.00)

Device type:

r0964[1] = 5700 --&gt; SINAMICS G120 CU230P-2\_DP

r0964[1] = 5701 --&gt; SINAMICS G120 CU230P-2\_PN

r0964[1] = 5702 --&gt; SINAMICS G120 CU230P-2\_CAN

r0964[1] = 5703 --&gt; SINAMICS G120 CU230P-2\_HVAC

r0964[1] = 5705 --&gt; SINAMICS G120 CU230P-2\_BT

<b>r0965</b>	<b>PROFIdrive profile number / PD profile number</b>		
	<b>Access level:</b> 3	<b>Calculated:</b> -	<b>Data type:</b> Unsigned16
	<b>Can be changed:</b> -	<b>Scaling:</b> -	<b>Dynamic index:</b> -
	<b>Unit group:</b> -	<b>Unit selection:</b> -	<b>Function diagram:</b> -
	<b>Min:</b>	<b>Max:</b>	<b>Factory setting:</b>
	-	-	-
<b>Description:</b>	Displays the PROFIdrive profile number and profile version. Constant value = 0329 hex. Byte 1: Profile number = 03 hex = PROFIdrive profile Byte 2: Profile version = 29 hex = Version 4.1		
	<b>Note</b>	When the parameter is read via PROFIdrive, the Octet String 2 data type applies.	
<b>p0969</b>	<b>System runtime relative / t_System relative</b>		
	<b>Access level:</b> 3	<b>Calculated:</b> -	<b>Data type:</b> Unsigned32
	<b>Can be changed:</b> T	<b>Scaling:</b> -	<b>Dynamic index:</b> -
	<b>Unit group:</b> -	<b>Unit selection:</b> -	<b>Function diagram:</b> 8050, 8060
	<b>Min:</b>	<b>Max:</b>	<b>Factory setting:</b>
	0 [ms]	4294967295 [ms]	0 [ms]
<b>Description:</b>	Displays the system runtime in ms since the last POWER ON.		
	<b>Note</b>	The value in p0969 can only be reset to 0. The value overflows after approx. 49 days. When the parameter is read via PROFIdrive, the TimeDifference data type applies.	
<b>p0970</b>	<b>Reset drive parameters / Drive par reset</b>		
	<b>Access level:</b> 1	<b>Calculated:</b> -	<b>Data type:</b> Unsigned16
	<b>Can be changed:</b> C2(1, 30)	<b>Scaling:</b> -	<b>Dynamic index:</b> -
	<b>Unit group:</b> -	<b>Unit selection:</b> -	<b>Function diagram:</b> -
	<b>Min:</b>	<b>Max:</b>	<b>Factory setting:</b>
	0	300	0
<b>Description:</b>	The parameter is used to initiate the reset of the drive parameters. Parameters p0100, p0205 are not reset. The following motor parameters are defined in accordance with the power unit: p0300 ... p0311.		
<b>Value:</b>	0: Inactive		

7.3 Parameter list

- 1: Start a parameter reset
- 3: Start download of volatile parameters from RAM
- 10: Start loading the parameters saved with p0971=10
- 11: Start loading the parameters saved with p0971=11
- 12: Start loading the parameters saved with p0971=12
- 30: Start loading the delivery state saved with p0971=30
- 100: Start a BICO interconnection reset
- 300: Only Siemens internal

**NOTICE**  
 After the value has been modified, no further parameter modifications can be made and the status is shown in r3996. Modifications can be made again when r3996 = 0.

**Note**  
 A factory setting run can only be started if p0010 was first set to 30 (parameter reset).  
 At the end of the calculations, p0970 is automatically set to 0.  
 Parameter reset is completed with p0970 = 0 and r3996[0] = 0.  
 The following generally applies:  
 One index of parameters p2100, p2101, p2118, p2119, p2126, p2127 is not reset, if a parameterized message is precisely active in this index.

**p0971**

**Save parameters / Save par**

<b>Access level:</b> 1	<b>Calculated:</b> -	<b>Data type:</b> Unsigned16
<b>Can be changed:</b> T, U	<b>Scaling:</b> -	<b>Dynamic index:</b> -
<b>Unit group:</b> -	<b>Unit selection:</b> -	<b>Function diagram:</b> -
<b>Min:</b> 0	<b>Max:</b> 30	<b>Factory setting:</b> 0

**Description:** Setting to save parameters in the non-volatile memory.  
 When saving, only the adjustable parameters intended to be saved are taken into account.

**Value:**

- 0: Inactive
- 1: Save drive object
- 10: Save in non-volatile memory as setting 10
- 11: Save in non-volatile memory as setting 11
- 12: Save in non-volatile memory as setting 12
- 30: State when delivered, save in non-volatile memory as setting 30

**Dependency:** See also: p0970, p1960, r3996

**CAUTION**  
 If a memory card (optional) is inserted – and the USB interface is not used, the following applies:  
 The parameters are also saved on the card and therefore overwrite any existing data!

**NOTICE**  
 The Control Unit power supply may only be switched off after data has been saved (i.e. after data save has been started, wait until the parameter again has the value 0).  
 Writing to parameters is inhibited while saving.  
 The progress while saving is displayed in r3996.  
 For p0971 = 30:  
 The original state when delivered is overwritten when executing this memory function.

**Note**  
 Parameters saved with p0971 = 10, 11, 12 can be loaded again with p0970 = 10, 11 or 12.  
 Identification and maintenance data (I&M data, p8806 and following) are only saved for p0971 = 1.



<b>p0972</b>	<b>Drive unit reset / Drv_unit reset</b>		
	<b>Access level:</b> 3	<b>Calculated:</b> -	<b>Data type:</b> Unsigned16
	<b>Can be changed:</b> T, U	<b>Scaling:</b> -	<b>Dynamic index:</b> -
	<b>Unit group:</b> -	<b>Unit selection:</b> -	<b>Function diagram:</b> -
	<b>Min:</b> 0	<b>Max:</b> 3	<b>Factory setting:</b> 0
<b>Description:</b>	Sets the required procedure to execute a hardware reset for the drive unit.		
<b>Value:</b>	0: Inactive 1: Hardware-Reset immediate 2: Hardware reset preparation 3: Hardware reset after cyclic communication has failed		
<b>⚠ DANGER</b>			
It must be absolutely ensured that the system is in a safe condition. The memory card/device memory of the Control Unit must not be accessed.			
<b>Note</b>			
If value = 1:			
Reset is immediately executed and communications interrupted.			
After communications have been established, check the reset operation (refer below).			
If value = 2:			
Help to check the reset operation.			
Firstly, set p0972 = 2 and then read back. Secondly, set p0972 = 1 (it is possible that this request is possibly no longer acknowledged). The communication is then interrupted.			
After communications have been established, check the reset operation (refer below).			
If value = 3:			
The reset is executed after interrupting cyclic communication. This setting is used to implement a synchronized reset by a control for several drive units.			
If cyclic communication is not active, then the reset is immediately executed.			
After communications have been established, check the reset operation (refer below).			
To check the reset operation:			
After the drive unit has been restarted and communications have been established, read p0972 and check the following:			
p0972 = 0? --> the reset was successfully executed.			
p0972 = 0? --> the reset was not executed.			
<b>p1000[0...n]</b>	<b>Speed setpoint selection / n_set sel</b>		
	<b>Access level:</b> 1	<b>Calculated:</b> -	<b>Data type:</b> Integer16
	<b>Can be changed:</b> T	<b>Scaling:</b> -	<b>Dynamic index:</b> CDS, p0170
	<b>Unit group:</b> -	<b>Unit selection:</b> -	<b>Function diagram:</b> -
	<b>Min:</b> 0	<b>Max:</b> 200	<b>Factory setting:</b> 6
<b>Description:</b>	Sets the source for the speed setpoint.		
	For single-digit values, the following applies:		
	The value specifies the main setpoint.		
	For double-digit values, the following applies:		
	The left-hand digit specifies the supplementary setpoint, the right-hand digit the main setpoint.		
	Example:		
	Value = 26		
	--> The analog setpoint (2) supplies the supplementary setpoint.		
	--> The fieldbus (6) supplies the main setpoint.		
<b>Value:</b>	0: No main setpoint 1: Motorized potentiometer 2: Analog setpoint		

7.3 Parameter list

- 3: Fixed speed setpoint
- 6: Fieldbus
- 7: Analog setpoint 2
- 10: Motor potentiometer + no main setpoint
- 11: Motor potentiometer + motor potentiometer
- 12: Motor potentiometer + analog setpoint
- 13: Motor potentiometer + fixed speed setpoint
- 16: Motor potentiometer + fieldbus
- 17: Motor potentiometer + analog setpoint 2
- 20: Analog setpoint + no main setpoint
- 21: Analog setpoint + motor potentiometer
- 22: Analog setpoint + analog setpoint
- 23: Analog setpoint + fixed speed setpoint
- 26: Analog setpoint + fieldbus
- 27: Analog setpoint + analog setpoint 2
- 30: Fixed speed setpoint + no main setpoint
- 31: Fixed speed setpoint + motor potentiometer
- 32: Fixed speed setpoint + analog setpoint
- 33: Fixed speed setpoint + fixed speed setpoint
- 36: Fixed speed setpoint + fieldbus
- 37: Fixed speed setpoint + analog setpoint 2
- 60: Fieldbus + no main setpoint
- 61: Fieldbus + motor potentiometer
- 62: Fieldbus + analog setpoint
- 63: Fieldbus + fixed speed setpoint
- 66: Fieldbus+fieldbus
- 67: Fieldbus + analog setpoint 2
- 70: Analog setpoint 2 + no main setpoint
- 71: Analog setpoint 2 + motor potentiometer
- 72: Analog setpoint 2 + analog setpoint
- 73: Analog setpoint 2 + fixed speed setpoint
- 76: Analog setpoint 2 + fieldbus
- 77: Analog setpoint 2 + analog setpoint 2
- 200: Analog output connection

**Dependency:** When changing this parameter, the following settings are influenced:  
See also: p1070, p1071, p1075, p1076

<b>CAUTION</b>
If p1000 is selected as the main setpoint of the fieldbus, the following BICO interconnection is set automatically: p2051[1] = r0063

<b>NOTICE</b>
The parameter is possibly protected as a result of p0922. For PROFIBUS/PROFINET Control Units, the following applies: The parameter can be freely set by setting p0922 = 999. When executing a specific macro, the corresponding programmed settings are made and become active.

<b>p1001[0...n]</b>	<b>CO: Fixed speed setpoint 1 / n_set_fixed 1</b>		
	<b>Access level:</b> 2	<b>Calculated:</b> -	<b>Data type:</b> FloatingPoint32
	<b>Can be changed:</b> T, U	<b>Scaling:</b> p2000	<b>Dynamic index:</b> DDS, p0180
	<b>Unit group:</b> 3_1	<b>Unit selection:</b> p0505	<b>Function diagram:</b> 3010
	<b>Min:</b> -210000.000 [rpm]	<b>Max:</b> 210000.000 [rpm]	<b>Factory setting:</b> 0.000 [rpm]
<b>Description:</b>	Setting and connector output for fixed speed setpoint 1.		
<b>Dependency:</b>	See also: p1020, p1021, p1022, p1023, r1024		

**NOTICE**

A BICO interconnection to a parameter that belongs to a drive data set always acts on the effective data set.

<b>p1002[0...n]</b>	<b>CO: Fixed speed setpoint 2 / n_set_fixed 2</b>		
	<b>Access level:</b> 2	<b>Calculated:</b> -	<b>Data type:</b> FloatingPoint32
	<b>Can be changed:</b> T, U	<b>Scaling:</b> p2000	<b>Dynamic index:</b> DDS, p0180
	<b>Unit group:</b> 3_1	<b>Unit selection:</b> p0505	<b>Function diagram:</b> 3010
	<b>Min:</b> -210000.000 [rpm]	<b>Max:</b> 210000.000 [rpm]	<b>Factory setting:</b> 0.000 [rpm]
<b>Description:</b>	Setting and connector output for fixed speed setpoint 2.		
<b>Dependency:</b>	See also: p1020, p1021, p1022, p1023, r1024		

**NOTICE**

A BICO interconnection to a parameter that belongs to a drive data set always acts on the effective data set.

<b>p1003[0...n]</b>	<b>CO: Fixed speed setpoint 3 / n_set_fixed 3</b>		
	<b>Access level:</b> 2	<b>Calculated:</b> -	<b>Data type:</b> FloatingPoint32
	<b>Can be changed:</b> T, U	<b>Scaling:</b> p2000	<b>Dynamic index:</b> DDS, p0180
	<b>Unit group:</b> 3_1	<b>Unit selection:</b> p0505	<b>Function diagram:</b> 3010
	<b>Min:</b> -210000.000 [rpm]	<b>Max:</b> 210000.000 [rpm]	<b>Factory setting:</b> 0.000 [rpm]
<b>Description:</b>	Setting and connector output for fixed speed setpoint 3.		
<b>Dependency:</b>	See also: p1020, p1021, p1022, p1023, r1024		

**NOTICE**

A BICO interconnection to a parameter that belongs to a drive data set always acts on the effective data set.

<b>p1004[0...n]</b>	<b>CO: Fixed speed setpoint 4 / n_set_fixed 4</b>		
	<b>Access level:</b> 2	<b>Calculated:</b> -	<b>Data type:</b> FloatingPoint32
	<b>Can be changed:</b> T, U	<b>Scaling:</b> p2000	<b>Dynamic index:</b> DDS, p0180
	<b>Unit group:</b> 3_1	<b>Unit selection:</b> p0505	<b>Function diagram:</b> 3010
	<b>Min:</b> -210000.000 [rpm]	<b>Max:</b> 210000.000 [rpm]	<b>Factory setting:</b> 0.000 [rpm]
<b>Description:</b>	Setting and connector output for fixed speed setpoint 4.		
<b>Dependency:</b>	See also: p1020, p1021, p1022, p1023, r1024		

**NOTICE**

A BICO interconnection to a parameter that belongs to a drive data set always acts on the effective data set.

<b>p1005[0...n]</b>	<b>CO: Fixed speed setpoint 5 / n_set_fixed 5</b>		
	<b>Access level:</b> 2	<b>Calculated:</b> -	<b>Data type:</b> FloatingPoint32
<b>Description:</b>	<b>Can be changed:</b> T, U	<b>Scaling:</b> p2000	<b>Dynamic index:</b> DDS, p0180
<b>Dependency:</b>	<b>Unit group:</b> 3_1	<b>Unit selection:</b> p0505	<b>Function diagram:</b> 3010
	<b>Min:</b>	<b>Max:</b>	<b>Factory setting:</b>
	-210000.000 [rpm]	210000.000 [rpm]	0.000 [rpm]
	Setting and connector output for fixed speed setpoint 5.		
	See also: p1020, p1021, p1022, p1023, r1024		

**NOTICE**

A BICO interconnection to a parameter that belongs to a drive data set always acts on the effective data set.

<b>p1006[0...n]</b>	<b>CO: Fixed speed setpoint 6 / n_set_fixed 6</b>		
	<b>Access level:</b> 2	<b>Calculated:</b> -	<b>Data type:</b> FloatingPoint32
<b>Description:</b>	<b>Can be changed:</b> T, U	<b>Scaling:</b> p2000	<b>Dynamic index:</b> DDS, p0180
<b>Dependency:</b>	<b>Unit group:</b> 3_1	<b>Unit selection:</b> p0505	<b>Function diagram:</b> 3010
	<b>Min:</b>	<b>Max:</b>	<b>Factory setting:</b>
	-210000.000 [rpm]	210000.000 [rpm]	0.000 [rpm]
	Setting and connector output for fixed speed setpoint 6.		
	See also: p1020, p1021, p1022, p1023, r1024		

**NOTICE**

A BICO interconnection to a parameter that belongs to a drive data set always acts on the effective data set.

<b>p1007[0...n]</b>	<b>CO: Fixed speed setpoint 7 / n_set_fixed 7</b>		
	<b>Access level:</b> 2	<b>Calculated:</b> -	<b>Data type:</b> FloatingPoint32
<b>Description:</b>	<b>Can be changed:</b> T, U	<b>Scaling:</b> p2000	<b>Dynamic index:</b> DDS, p0180
<b>Dependency:</b>	<b>Unit group:</b> 3_1	<b>Unit selection:</b> p0505	<b>Function diagram:</b> 3010
	<b>Min:</b>	<b>Max:</b>	<b>Factory setting:</b>
	-210000.000 [rpm]	210000.000 [rpm]	0.000 [rpm]
	Setting and connector output for fixed speed setpoint 7.		
	See also: p1020, p1021, p1022, p1023, r1024		

**NOTICE**

A BICO interconnection to a parameter that belongs to a drive data set always acts on the effective data set.

<b>p1008[0...n]</b>	<b>CO: Fixed speed setpoint 8 / n_set_fixed 8</b>		
	<b>Access level:</b> 2	<b>Calculated:</b> -	<b>Data type:</b> FloatingPoint32
<b>Description:</b>	<b>Can be changed:</b> T, U	<b>Scaling:</b> p2000	<b>Dynamic index:</b> DDS, p0180
<b>Dependency:</b>	<b>Unit group:</b> 3_1	<b>Unit selection:</b> p0505	<b>Function diagram:</b> 3010
	<b>Min:</b>	<b>Max:</b>	<b>Factory setting:</b>
	-210000.000 [rpm]	210000.000 [rpm]	0.000 [rpm]
	Setting and connector output for fixed speed setpoint 8.		
	See also: p1020, p1021, p1022, p1023, r1024		

**NOTICE**

A BICO interconnection to a parameter that belongs to a drive data set always acts on the effective data set.

<b>p1009[0...n]</b>	<b>CO: Fixed speed setpoint 9 / n_set_fixed 9</b>		
	<b>Access level:</b> 2	<b>Calculated:</b> -	<b>Data type:</b> FloatingPoint32
	<b>Can be changed:</b> T, U	<b>Scaling:</b> p2000	<b>Dynamic index:</b> DDS, p0180
	<b>Unit group:</b> 3_1	<b>Unit selection:</b> p0505	<b>Function diagram:</b> 3010
	<b>Min:</b> -210000.000 [rpm]	<b>Max:</b> 210000.000 [rpm]	<b>Factory setting:</b> 0.000 [rpm]
<b>Description:</b>	Setting and connector output for fixed speed setpoint 9.		
<b>Dependency:</b>	See also: p1020, p1021, p1022, p1023, r1024		

**NOTICE**

A BICO interconnection to a parameter that belongs to a drive data set always acts on the effective data set.

<b>p1010[0...n]</b>	<b>CO: Fixed speed setpoint 10 / n_set_fixed 10</b>		
	<b>Access level:</b> 2	<b>Calculated:</b> -	<b>Data type:</b> FloatingPoint32
	<b>Can be changed:</b> T, U	<b>Scaling:</b> p2000	<b>Dynamic index:</b> DDS, p0180
	<b>Unit group:</b> 3_1	<b>Unit selection:</b> p0505	<b>Function diagram:</b> 3010
	<b>Min:</b> -210000.000 [rpm]	<b>Max:</b> 210000.000 [rpm]	<b>Factory setting:</b> 0.000 [rpm]
<b>Description:</b>	Setting and connector output for fixed speed setpoint 10.		
<b>Dependency:</b>	See also: p1020, p1021, p1022, p1023, r1024		

**NOTICE**

A BICO interconnection to a parameter that belongs to a drive data set always acts on the effective data set.

<b>p1011[0...n]</b>	<b>CO: Fixed speed setpoint 11 / n_set_fixed 11</b>		
	<b>Access level:</b> 2	<b>Calculated:</b> -	<b>Data type:</b> FloatingPoint32
	<b>Can be changed:</b> T, U	<b>Scaling:</b> p2000	<b>Dynamic index:</b> DDS, p0180
	<b>Unit group:</b> 3_1	<b>Unit selection:</b> p0505	<b>Function diagram:</b> 3010
	<b>Min:</b> -210000.000 [rpm]	<b>Max:</b> 210000.000 [rpm]	<b>Factory setting:</b> 0.000 [rpm]
<b>Description:</b>	Setting and connector output for fixed speed setpoint 11.		
<b>Dependency:</b>	See also: p1020, p1021, p1022, p1023, r1024		

**NOTICE**

A BICO interconnection to a parameter that belongs to a drive data set always acts on the effective data set.

<b>p1012[0...n]</b>	<b>CO: Fixed speed setpoint 12 / n_set_fixed 12</b>		
	<b>Access level:</b> 2	<b>Calculated:</b> -	<b>Data type:</b> FloatingPoint32
	<b>Can be changed:</b> T, U	<b>Scaling:</b> p2000	<b>Dynamic index:</b> DDS, p0180
	<b>Unit group:</b> 3_1	<b>Unit selection:</b> p0505	<b>Function diagram:</b> 3010
	<b>Min:</b> -210000.000 [rpm]	<b>Max:</b> 210000.000 [rpm]	<b>Factory setting:</b> 0.000 [rpm]
<b>Description:</b>	Setting and connector output for fixed speed setpoint 12.		
<b>Dependency:</b>	See also: p1020, p1021, p1022, p1023, r1024		

**NOTICE**

A BICO interconnection to a parameter that belongs to a drive data set always acts on the effective data set.

7.3 Parameter list

**p1013[0...n]**      **CO: Fixed speed setpoint 13 / n\_set\_fixed 13**

<b>Access level:</b> 2	<b>Calculated:</b> -	<b>Data type:</b> FloatingPoint32
<b>Can be changed:</b> T, U	<b>Scaling:</b> p2000	<b>Dynamic index:</b> DDS, p0180
<b>Unit group:</b> 3_1	<b>Unit selection:</b> p0505	<b>Function diagram:</b> 3010
<b>Min:</b> -210000.000 [rpm]	<b>Max:</b> 210000.000 [rpm]	<b>Factory setting:</b> 0.000 [rpm]

**Description:** Setting and connector output for fixed speed setpoint 13.  
**Dependency:** See also: p1020, p1021, p1022, p1023, r1024

<b>NOTICE</b>
A BICO interconnection to a parameter that belongs to a drive data set always acts on the effective data set.

**p1014[0...n]**      **CO: Fixed speed setpoint 14 / n\_set\_fixed 14**

<b>Access level:</b> 2	<b>Calculated:</b> -	<b>Data type:</b> FloatingPoint32
<b>Can be changed:</b> T, U	<b>Scaling:</b> p2000	<b>Dynamic index:</b> DDS, p0180
<b>Unit group:</b> 3_1	<b>Unit selection:</b> p0505	<b>Function diagram:</b> 3010
<b>Min:</b> -210000.000 [rpm]	<b>Max:</b> 210000.000 [rpm]	<b>Factory setting:</b> 0.000 [rpm]

**Description:** Setting and connector output for fixed speed setpoint 14.  
**Dependency:** See also: p1020, p1021, p1022, p1023, r1024

<b>NOTICE</b>
A BICO interconnection to a parameter that belongs to a drive data set always acts on the effective data set.

**p1015[0...n]**      **CO: Fixed speed setpoint 15 / n\_set\_fixed 15**

<b>Access level:</b> 2	<b>Calculated:</b> -	<b>Data type:</b> FloatingPoint32
<b>Can be changed:</b> T, U	<b>Scaling:</b> p2000	<b>Dynamic index:</b> DDS, p0180
<b>Unit group:</b> 3_1	<b>Unit selection:</b> p0505	<b>Function diagram:</b> 3010
<b>Min:</b> -210000.000 [rpm]	<b>Max:</b> 210000.000 [rpm]	<b>Factory setting:</b> 0.000 [rpm]

**Description:** Setting and connector output for fixed speed setpoint 15.  
**Dependency:** See also: p1020, p1021, p1022, p1023, r1024

<b>NOTICE</b>
A BICO interconnection to a parameter that belongs to a drive data set always acts on the effective data set.

**p1016**      **Fixed speed setpoint select mode / n\_set\_fix select**

<b>Access level:</b> 2	<b>Calculated:</b> -	<b>Data type:</b> Integer16
<b>Can be changed:</b> T	<b>Scaling:</b> -	<b>Dynamic index:</b> -
<b>Unit group:</b> -	<b>Unit selection:</b> -	<b>Function diagram:</b> 3010, 3011
<b>Min:</b> 1	<b>Max:</b> 2	<b>Factory setting:</b> 1

**Description:** Sets the mode to select the fixed speed setpoint.  
**Value:**  
 1:          Direct  
 2:          Binary

**Note**  
 For p1016 = 1:  
 In this mode, the setpoint is entered via the fixed speed setpoints p1001 ... p1004.  
 Up to 16 different setpoints are obtained by adding the individual fixed speed setpoints.  
 For p1016 = 2:  
 In this mode, the setpoint is entered via the fixed speed setpoints p1001 ... p1015.

<b>p1020[0...n]</b>	<b>BI: Fixed speed setpoint selection Bit 0 / n_set_fixed Bit 0</b>		
	<b>Access level:</b> 3	<b>Calculated:</b> -	<b>Data type:</b> Unsigned32 / Binary
	<b>Can be changed:</b> T	<b>Scaling:</b> -	<b>Dynamic index:</b> CDS, p0170
	<b>Unit group:</b> -	<b>Unit selection:</b> -	<b>Function diagram:</b> 2505, 3010, 3011
	<b>Min:</b> -	<b>Max:</b> -	<b>Factory setting:</b> 0
<b>Description:</b>	Sets the signal source for selecting the fixed speed setpoint.		
<b>Dependency:</b>	Selects the required fixed speed setpoint using p1020 ... p1023. Displays the number of the actual fixed speed setpoint in r1197. Sets the values for the fixed speed setpoints 1 ... 15 using p1001 ... p1015. See also: p1021, p1022, p1023		
	<b>Note</b> If a fixed speed setpoint has not been selected (p1020 ... p1023 = 0, r1197 = 0), then r1024 = 0 (setpoint = 0).		
<b>p1021[0...n]</b>	<b>BI: Fixed speed setpoint selection Bit 1 / n_set_fixed Bit 1</b>		
	<b>Access level:</b> 3	<b>Calculated:</b> -	<b>Data type:</b> Unsigned32 / Binary
	<b>Can be changed:</b> T	<b>Scaling:</b> -	<b>Dynamic index:</b> CDS, p0170
	<b>Unit group:</b> -	<b>Unit selection:</b> -	<b>Function diagram:</b> 2505, 3010, 3011
	<b>Min:</b> -	<b>Max:</b> -	<b>Factory setting:</b> 0
<b>Description:</b>	Sets the signal source for selecting the fixed speed setpoint.		
<b>Dependency:</b>	Selects the required fixed speed setpoint using p1020 ... p1023. Displays the number of the actual fixed speed setpoint in r1197. Sets the values for the fixed speed setpoints 1 ... 15 using p1001 ... p1015. See also: p1020, p1022, p1023		
	<b>Note</b> If a fixed speed setpoint has not been selected (p1020 ... p1023 = 0, r1197 = 0), then r1024 = 0 (setpoint = 0).		
<b>p1022[0...n]</b>	<b>BI: Fixed speed setpoint selection Bit 2 / n_set_fixed Bit 2</b>		
	<b>Access level:</b> 3	<b>Calculated:</b> -	<b>Data type:</b> Unsigned32 / Binary
	<b>Can be changed:</b> T	<b>Scaling:</b> -	<b>Dynamic index:</b> CDS, p0170
	<b>Unit group:</b> -	<b>Unit selection:</b> -	<b>Function diagram:</b> 2505, 3010, 3011
	<b>Min:</b> -	<b>Max:</b> -	<b>Factory setting:</b> 0
<b>Description:</b>	Sets the signal source for selecting the fixed speed setpoint.		
<b>Dependency:</b>	Selects the required fixed speed setpoint using p1020 ... p1023. Displays the number of the actual fixed speed setpoint in r1197. Sets the values for the fixed speed setpoints 1 ... 15 using p1001 ... p1015. See also: p1020, p1021, p1023		
	<b>Note</b> If a fixed speed setpoint has not been selected (p1020 ... p1023 = 0, r1197 = 0), then r1024 = 0 (setpoint = 0).		

7.3 Parameter list

<b>p1023[0...n]</b>	<b>BI: Fixed speed setpoint selection Bit 3 / n_set_fixed Bit 3</b>													
<b>Access level:</b>	3	<b>Calculated:</b>	Data type: Unsigned32 / Binary											
<b>Can be changed:</b>	T	<b>Scaling:</b>	Dynamic index: CDS, p0170											
<b>Unit group:</b>	-	<b>Unit selection:</b>	Function diagram: 2505, 3010, 3011											
<b>Min:</b>	-	<b>Max:</b>	Factory setting:											
<b>Description:</b>	Sets the signal source for selecting the fixed speed setpoint.													
<b>Dependency:</b>	Selects the required fixed speed setpoint using p1020 ... p1023. Displays the number of the actual fixed speed setpoint in r1197. Sets the values for the fixed speed setpoints 1 ... 15 using p1001 ... p1015. See also: p1020, p1021, p1022													
<b>Note</b>	If a fixed speed setpoint has not been selected (p1020 ... p1023 = 0, r1197 = 0), then r1024 = 0 (setpoint = 0).													
<b>r1024</b>	<b>CO: Fixed speed setpoint effective / Speed fixed setp</b>													
<b>Access level:</b>	3	<b>Calculated:</b>	Data type: FloatingPoint32											
<b>Can be changed:</b>	-	<b>Scaling:</b>	Dynamic index: -											
<b>Unit group:</b>	3_1	<b>Unit selection:</b>	Function diagram: 3001, 3010, 3011											
<b>Min:</b>	- [rpm]	<b>Max:</b>	Factory setting:											
<b>Description:</b>	Display and connector output for the selected and active fixed speed setpoint. This setpoint is the output value for the fixed speed setpoints and must be appropriately interconnected (e.g. with the main setpoint).													
<b>Recommendation:</b>	Interconnect the signal with the main setpoint (CI: p1070 = r1024).													
<b>Dependency:</b>	Selects the required fixed speed setpoint using p1020 ... p1023. Displays the number of the actual fixed speed setpoint in r1197. Sets the values for the fixed speed setpoints 1 ... 15 using p1001 ... p1015. See also: p1070													
<b>Note</b>	If a fixed speed setpoint has not been selected (p1020 ... p1023 = 0, r1197 = 0), then r1024 = 0 (setpoint = 0).													
<b>r1025.0</b>	<b>BO: Fixed speed setpoint status / n_setp_fix status</b>													
<b>Access level:</b>	3	<b>Calculated:</b>	Data type: Unsigned8											
<b>Can be changed:</b>	-	<b>Scaling:</b>	Dynamic index: -											
<b>Unit group:</b>	-	<b>Unit selection:</b>	Function diagram: -											
<b>Min:</b>	-	<b>Max:</b>	Factory setting:											
<b>Description:</b>	Display and binector output for the status when selecting the fixed speed setpoints.													
<b>Bit field:</b>	<table border="1"> <thead> <tr> <th>Bit</th> <th>Signal name</th> <th>1 signal</th> <th>0 signal</th> <th>FP</th> </tr> </thead> <tbody> <tr> <td>00</td> <td>Fixed speed setpoint selected</td> <td>Yes</td> <td>No</td> <td>3011</td> </tr> </tbody> </table>	Bit	Signal name	1 signal	0 signal	FP	00	Fixed speed setpoint selected	Yes	No	3011	1 signal	0 signal	FP
Bit	Signal name	1 signal	0 signal	FP										
00	Fixed speed setpoint selected	Yes	No	3011										
<b>Dependency:</b>	See also: p1016													
<b>Note</b>	For bit 00: When the fixed speed setpoints are directly selected (p1016 = 1), this bit is set if at least 1 fixed speed setpoint is selected.													



<b>p1030[0...n]</b>	<b>Motorized potentiometer configuration / Mop configuration</b>			
	<b>Access level:</b> 3	<b>Calculated:</b> -	<b>Data type:</b> Unsigned16	
	<b>Can be changed:</b> T, U	<b>Scaling:</b> -	<b>Dynamic index:</b> DDS, p0180	
	<b>Unit group:</b> -	<b>Unit selection:</b> -	<b>Function diagram:</b> 3020	
	<b>Min:</b> -	<b>Max:</b> -	<b>Factory setting:</b> 0000 0110 bin	
<b>Description:</b>	Sets the configuration for the motorized potentiometer.			
<b>Bit field:</b>	<b>Bit</b>	<b>Signal name</b>	<b>1 signal</b>	<b>0 signal</b>
	00	Data save active	Yes	No
	01	Automatic mode ramp-function generator active	Yes	No
	02	Initial rounding-off active	Yes	No
	03	Save in NVRAM active	Yes	No
	04	Ramp-function generator always active	Yes	No
	<b>Note</b>			
	For bit 00:			
	0: The setpoint for the motorized potentiometer is not saved and after ON is entered using p1040.			
	1: The setpoint for the motorized potentiometer is saved after OFF and after ON set to the saved value. In order to save in a non-volatile fashion, bit 03 should be set to 1.			
	For bit 01:			
	0: Without ramp-function generator in the automatic mode (ramp-up/ramp-down time = 0).			
	1: With ramp-function generator in the automatic mode.			
	For manual operation (0 signal via BI: p1041), the ramp-function generator is always active.			
	For bit 02:			
	0: Without initial rounding-off			
	1: With initial rounding-off. The selected ramp-up/down time is correspondingly exceeded. The initial rounding-off is a sensitive way of specifying small changes (progressive reaction when keys are pressed).			
	The jerk for the initial rounding-off is independent of the ramp-up time and only depends on the selected maximum speed (p1082). It is calculated as follows:			
	$r = 0.01 \% * p1082 [1/s] / 0.13^2 [s^2]$			
	The jerk acts up until the maximum acceleration is reached ( $a_{max} = p1082 [1/s] / p1047 [s]$ ), and then the drive continues to run linearly with a constant rate of acceleration. The higher the maximum acceleration (the lower that p1047 is), the longer the ramp-up time increases with respect to the set ramp-up time.			
	For bit 03:			
	0: Non-volatile data save deactivated.			
	1: The setpoint for the motorized potentiometer is saved in a non-volatile fashion (for bit 00 = 1).			
	For bit 04:			
	When the bit is set, the ramp-function generator is computed independent of the pulse enable. The actual output value of the motorized potentiometer is always in r1050.			

<b>p1035[0...n]</b>	<b>BI: Motorized potentiometer setpoint raise / Mop raise</b>			
	<b>Access level:</b> 3	<b>Calculated:</b> -	<b>Data type:</b> Unsigned32 / Binary	
	<b>Can be changed:</b> T	<b>Scaling:</b> -	<b>Dynamic index:</b> CDS, p0170	
	<b>Unit group:</b> -	<b>Unit selection:</b> -	<b>Function diagram:</b> 2505, 3020	
	<b>Min:</b> -	<b>Max:</b> -	<b>Factory setting:</b> [0] 2090.13 [1] 0 [2] 0 [3] 0	
<b>Description:</b>	Sets the signal source to continually increase the setpoint for the motorized potentiometer. The setpoint change (CO: r1050) depends on the set ramp-up time (p1047) and the duration of the signal that is present (BI: p1035).			
<b>Dependency:</b>	See also: p1036			

**NOTICE**

The parameter may be protected as a result of p0922 or p2079 and cannot be changed.

<b>p1036[0...n]</b>	<b>BI: Motorized potentiometer lower setpoint / Mop lower</b>		
<b>Access level:</b> 3	<b>Calculated:</b> -	<b>Data type:</b> Unsigned32 / Binary	
<b>Can be changed:</b> T	<b>Scaling:</b> -	<b>Dynamic index:</b> CDS, p0170	
<b>Unit group:</b> -	<b>Unit selection:</b> -	<b>Function diagram:</b> 2505, 3020	
<b>Min:</b>	<b>Max:</b>	<b>Factory setting:</b>	
-	-	[0] 2090.14	
		[1] 0	
		[2] 0	
		[3] 0	

**Description:** Sets the signal source to continuously lower the setpoint for the motorized potentiometer. The setpoint change (CO: r1050) depends on the set ramp-down time (p1048) and the duration of the signal that is present (BI: p1036).

**Dependency:** See also: p1035

**NOTICE**

The parameter may be protected as a result of p0922 or p2079 and cannot be changed.

<b>p1037[0...n]</b>	<b>Motorized potentiometer maximum speed / MotP n_max</b>		
<b>Access level:</b> 3	<b>Calculated:</b> CALC_MOD_LIM_REF	<b>Data type:</b> FloatingPoint32	
<b>Can be changed:</b> T, U	<b>Scaling:</b> -	<b>Dynamic index:</b> DDS, p0180	
<b>Unit group:</b> 3_1	<b>Unit selection:</b> p0505	<b>Function diagram:</b> 3020	
<b>Min:</b>	<b>Max:</b>	<b>Factory setting:</b>	
-210000.000 [rpm]	210000.000 [rpm]	0.000 [rpm]	

**Description:** Sets the maximum speed/velocity for the motorized potentiometer.

**Note**

This parameter is automatically pre-assigned in the commissioning phase. The setpoint output from the motorized potentiometer is limited to this value (see function diagram 3020).

<b>p1038[0...n]</b>	<b>Motorized potentiometer minimum speed / MotP n_min</b>		
<b>Access level:</b> 3	<b>Calculated:</b> CALC_MOD_LIM_REF	<b>Data type:</b> FloatingPoint32	
<b>Can be changed:</b> T, U	<b>Scaling:</b> -	<b>Dynamic index:</b> DDS, p0180	
<b>Unit group:</b> 3_1	<b>Unit selection:</b> p0505	<b>Function diagram:</b> 3020	
<b>Min:</b>	<b>Max:</b>	<b>Factory setting:</b>	
-210000.000 [rpm]	210000.000 [rpm]	0.000 [rpm]	

**Description:** Sets the minimum speed/velocity for the motorized potentiometer.

**Note**

This parameter is automatically pre-assigned in the commissioning phase. The setpoint output from the motorized potentiometer is limited to this value (see function diagram 3020).

<b>p1039[0...n]</b>	<b>BI: Motorized potentiometer inversion / MotP inv</b>		
<b>Access level:</b> 3	<b>Calculated:</b> -	<b>Data type:</b> Unsigned32 / Binary	
<b>Can be changed:</b> T	<b>Scaling:</b> -	<b>Dynamic index:</b> CDS, p0170	
<b>Unit group:</b> -	<b>Unit selection:</b> -	<b>Function diagram:</b> 3020	
<b>Min:</b>	<b>Max:</b>	<b>Factory setting:</b>	
-	-	0	

**Description:** Sets the signal source to invert the minimum speed/velocity or the maximum speed/velocity for the motorized potentiometer.

**Dependency:** See also: p1037, p1038

**Note**

The inversion is only active during "motorized potentiometer raise" or "motorized potentiometer lower".

**p1040[0...n] Motorized potentiometer starting value / Mop start value**

**Access level:** 2

**Calculated:** -

**Data type:** FloatingPoint32

**Can be changed:** T, U

**Scaling:** -

**Dynamic index:** DDS, p0180

**Unit group:** 3\_1

**Unit selection:** p0505

**Function diagram:** 3020

**Min:**

**Max:**

**Factory setting:**

-210000.000 [rpm]

210000.000 [rpm]

0.000 [rpm]

**Description:** Sets the starting value for the motorized potentiometer. This starting value becomes effective after the drive has been switched on.

**Dependency:** Only effective if p1030.0 = 0.

See also: p1030

**p1041[0...n] BI: Motorized potentiometer manual/automatic / Mop manual/auto**

**Access level:** 3

**Calculated:** -

**Data type:** Unsigned32 / Binary

**Can be changed:** T

**Scaling:** -

**Dynamic index:** CDS, p0170

**Unit group:** -

**Unit selection:** -

**Function diagram:** 3020

**Min:**

**Max:**

**Factory setting:**

-

-

0

**Description:** Sets the signal source to change over from manual to automatic when using a motorized potentiometer.

In the manual mode, the setpoint is changed using two signals - raise and lower. In the automatic mode, the setpoint must be interconnected via a connector input.

**Dependency:** See also: p1030, p1035, p1036, p1042

**Note**

The effectiveness of the internal ramp-function generator can be set in automatic mode.

**p1042[0...n] CI: Motorized potentiometer automatic setpoint / Mop auto setpoint**

**Access level:** 3

**Calculated:** -

**Data type:** Unsigned32 / FloatingPoint32

**Can be changed:** T

**Scaling:** p2000

**Dynamic index:** CDS, p0170

**Unit group:** -

**Unit selection:** -

**Function diagram:** 3020

**Min:**

**Max:**

**Factory setting:**

-

-

0

**Description:** Sets the signal source for the setpoint of the motorized potentiometer in the automatic mode.

**Dependency:** See also: p1041

**p1043[0...n] BI: Motorized potentiometer accept setting value / MotP acc set val**

**Access level:** 3

**Calculated:** -

**Data type:** Unsigned32 / Binary

**Can be changed:** T

**Scaling:** -

**Dynamic index:** CDS, p0170

**Unit group:** -

**Unit selection:** -

**Function diagram:** 3020

**Min:**

**Max:**

**Factory setting:**

-

-

0

**Description:** Sets the signal source to accept the setting value for the motorized potentiometer.

**Dependency:** See also: p1044

**Note**

The setting value (CI: p1044) becomes effective for a 0/1 edge of the setting command (BI: p1043).

<b>p1044[0...n]</b>	<b>CI: Motorized potentiometer setting value / Mop set val</b>		
	<b>Access level:</b> 3	<b>Calculated:</b> -	<b>Data type:</b> Unsigned32 / FloatingPoint32
	<b>Can be changed:</b> T	<b>Scaling:</b> p2000	<b>Dynamic index:</b> CDS, p0170
	<b>Unit group:</b> -	<b>Unit selection:</b> -	<b>Function diagram:</b> 3020
	<b>Min:</b> -	<b>Max:</b> -	<b>Factory setting:</b> 0
<b>Description:</b>	Sets the signal source for the setting value for the motorized potentiometer.		
<b>Dependency:</b>	See also: p1043		

**Note**

The setting value (CI: p1044) becomes effective for a 0/1 edge of the setting command (BI: p1043).

<b>r1045</b>	<b>CO: Mot. potentiometer speed setp. in front of ramp-fct. gen. / Mop n_set bef RFG</b>		
	<b>Access level:</b> 3	<b>Calculated:</b> -	<b>Data type:</b> FloatingPoint32
	<b>Can be changed:</b> -	<b>Scaling:</b> p2000	<b>Dynamic index:</b> -
	<b>Unit group:</b> 3_1	<b>Unit selection:</b> p0505	<b>Function diagram:</b> 3020
	<b>Min:</b> - [rpm]	<b>Max:</b> - [rpm]	<b>Factory setting:</b> - [rpm]
<b>Description:</b>	Sets the effective setpoint in front of the internal motorized potentiometer ramp-function generator.		

<b>p1047[0...n]</b>	<b>Motorized potentiometer ramp-up time / Mop ramp-up time</b>		
	<b>Access level:</b> 2	<b>Calculated:</b> -	<b>Data type:</b> FloatingPoint32
	<b>Can be changed:</b> T, U	<b>Scaling:</b> -	<b>Dynamic index:</b> DDS, p0180
	<b>Unit group:</b> -	<b>Unit selection:</b> -	<b>Function diagram:</b> 3020
	<b>Min:</b> 0.000 [s]	<b>Max:</b> 1000.000 [s]	<b>Factory setting:</b> 10.000 [s]
<b>Description:</b>	Sets the ramp-up time for the internal ramp-function generator for the motorized potentiometer. The setpoint is changed from zero up to the speed/velocity limit (p1082) within this time (if no initial rounding-off has been activated).		
<b>Dependency:</b>	See also: p1030, p1048, p1082		

**Note**

When the initial rounding-off is activated (p1030.2) the ramp-up time is correspondingly extended.

<b>p1048[0...n]</b>	<b>Motorized potentiometer ramp-down time / Mop ramp-down time</b>		
	<b>Access level:</b> 2	<b>Calculated:</b> -	<b>Data type:</b> FloatingPoint32
	<b>Can be changed:</b> T, U	<b>Scaling:</b> -	<b>Dynamic index:</b> DDS, p0180
	<b>Unit group:</b> -	<b>Unit selection:</b> -	<b>Function diagram:</b> 3020
	<b>Min:</b> 0.000 [s]	<b>Max:</b> 1000.000 [s]	<b>Factory setting:</b> 10.000 [s]
<b>Description:</b>	Sets the ramp-down time for the internal ramp-function generator for the motorized potentiometer. The setpoint is changed from the speed/velocity limit (p1082) to zero within this time (if no initial rounding-off has been activated).		
<b>Dependency:</b>	See also: p1030, p1047, p1082		

**Note**

The deceleration time is extended corresponding to the activated initial rounding-off (p1030.2).

<b>r1050</b>	<b>CO: Motorized potentiometer setpoint after ramp-function generator / Mot poti setpoint</b>		
	<b>Access level:</b> 2	<b>Calculated:</b> -	<b>Data type:</b> FloatingPoint32
	<b>Can be changed:</b> -	<b>Scaling:</b> p2000	<b>Dynamic index:</b> -
	<b>Unit group:</b> 3_1	<b>Unit selection:</b> p0505	<b>Function diagram:</b> 3001, 3020
	<b>Min:</b> - [rpm]	<b>Max:</b> - [rpm]	<b>Factory setting:</b> - [rpm]
<b>Description:</b>	Sets the effective setpoint after the internal motorized potentiometer ramp-function generator. This setpoint is the output value of the motorized potentiometer and must be appropriately interconnected onwards (e.g. with the main setpoint).		
<b>Recommendation:</b>	Interconnect the signal with main setpoint (p1070).		
<b>Dependency:</b>	See also: p1070		
	<b>Note</b> For "With ramp-function generator", after an OFF1, OFF2, OFF3 or for a 0 signal via BI: p0852 (inhibit operation, suppress pulses) the ramp-function generator output (r1050) is set to the starting value (configuration via p1030.0).		
<b>p1051[0...n]</b>	<b>CI: Speed limit RFG positive direction of rotation / n_limit RFG pos</b>		
	<b>Access level:</b> 3	<b>Calculated:</b> -	<b>Data type:</b> Unsigned32 / FloatingPoint32
	<b>Can be changed:</b> T	<b>Scaling:</b> p2000	<b>Dynamic index:</b> CDS, p0170
	<b>Unit group:</b> -	<b>Unit selection:</b> -	<b>Function diagram:</b> 3050
	<b>Min:</b> -	<b>Max:</b> -	<b>Factory setting:</b> 1083[0]
<b>Description:</b>	Sets the signal source for the speed limit of the positive direction on the ramp-function generator input.		
	<b>Note</b> The OFF3 ramp-down time (p1135) is effective when the limit is reduced.		
<b>p1052[0...n]</b>	<b>CI: Speed limit RFG negative direction of rotation / n_limit RFG neg</b>		
	<b>Access level:</b> 3	<b>Calculated:</b> -	<b>Data type:</b> Unsigned32 / FloatingPoint32
	<b>Can be changed:</b> T	<b>Scaling:</b> p2000	<b>Dynamic index:</b> CDS, p0170
	<b>Unit group:</b> -	<b>Unit selection:</b> -	<b>Function diagram:</b> 3050
	<b>Min:</b> -	<b>Max:</b> -	<b>Factory setting:</b> 1086[0]
<b>Description:</b>	Sets the signal source for the speed limit of the negative direction on the ramp-function generator input.		
	<b>Note</b> The OFF3 ramp-down time (p1135) is effective when the limit is reduced.		
<b>p1055[0...n]</b>	<b>BI: Jog bit 0 / Jog bit 0</b>		
	<b>Access level:</b> 3	<b>Calculated:</b> -	<b>Data type:</b> Unsigned32 / Binary
	<b>Can be changed:</b> T	<b>Scaling:</b> -	<b>Dynamic index:</b> CDS, p0170
	<b>Unit group:</b> -	<b>Unit selection:</b> -	<b>Function diagram:</b> 2501, 3030
	<b>Min:</b> -	<b>Max:</b> -	<b>Factory setting:</b> [0] 0 [1] 722.0 [2] 0 [3] 0
<b>Description:</b>	Sets the signal source for jog 1.		
<b>Recommendation:</b>	When the setting for this binector input is changed, the motor can only be switched on by means of an appropriate signal change of the source.		

7.3 Parameter list

**Dependency:** See also: p0840, p1058

**NOTICE**  
 The drive is enabled for jogging using BI: p1055 or BI: p1056.  
 The command "ON/OFF1" can be issued using BI: p0840 or using BI: p1055/p1056.  
 Only the signal source that was used to switch on can also be used to switch off again.

**p1056[0...n]**

**BI: Jog bit 1 / Jog bit 1**

**Access level:** 3

**Calculated:** -

**Data type:** Unsigned32 / Binary

**Can be changed:** T

**Scaling:** -

**Dynamic index:** CDS, p0170

**Unit group:** -

**Unit selection:** -

**Function diagram:** 2501, 3030

**Min:**

**Max:**

**Factory setting:**

-

-

[0] 0

[1] 722.1

[2] 0

[3] 0

**Description:** Sets the signal source for jog 2.

**Recommendation:** When the setting for this binector input is changed, the motor can only be switched on by means of an appropriate signal change of the source.

**Dependency:** See also: p0840, p1059

**NOTICE**  
 The drive is enabled for jogging using BI: p1055 or BI: p1056.  
 The command "ON/OFF1" can be issued using BI: p0840 or using BI: p1055/p1056.  
 Only the signal source that was used to switch on can also be used to switch off again.

**p1058[0...n]**

**Jog 1 speed setpoint / Jog 1 n\_set**

**Access level:** 2

**Calculated:** -

**Data type:** FloatingPoint32

**Can be changed:** T

**Scaling:** -

**Dynamic index:** DDS, p0180

**Unit group:** 3\_1

**Unit selection:** p0505

**Function diagram:** 3001, 3030

**Min:**

**Max:**

**Factory setting:**

-210000.000 [rpm]

210000.000 [rpm]

150.000 [rpm]

**Description:** Sets the speed for jog 1.

Jogging (JOG) is level-triggered, and allows the motor to be incrementally traversed.

**Dependency:** See also: p1055, p1056

**p1059[0...n]**

**Jog 2 speed setpoint / Jog 2 n\_set**

**Access level:** 2

**Calculated:** -

**Data type:** FloatingPoint32

**Can be changed:** T

**Scaling:** -

**Dynamic index:** DDS, p0180

**Unit group:** 3\_1

**Unit selection:** p0505

**Function diagram:** 3001, 3030

**Min:**

**Max:**

**Factory setting:**

-210000.000 [rpm]

210000.000 [rpm]

-150.000 [rpm]

**Description:** Sets the speed for jog 2.

Jogging (JOG) is level-triggered, and allows the motor to be incrementally traversed.

**Dependency:** See also: p1055, p1056

<b>p1063[0...n]</b>	<b>Setpoint channel speed limit / Setp_chan n_lim</b>		
	<b>Access level:</b> 3	<b>Calculated:</b> -	<b>Data type:</b> FloatingPoint32
<b>Description:</b>	<b>Can be changed:</b> T, U	<b>Scaling:</b> -	<b>Dynamic index:</b> DDS, p0180
	<b>Unit group:</b> 3_1	<b>Unit selection:</b> p0505	<b>Function diagram:</b> 3040
<b>Dependency:</b>	<b>Min:</b> 0.000 [rpm]	<b>Max:</b> 210000.000 [rpm]	<b>Factory setting:</b> 210000.000 [rpm]
	Sets the speed limit effective in the setpoint channel.		

<b>p1070[0...n]</b>	<b>CI: Main setpoint / Main setpoint</b>		
	<b>Access level:</b> 3	<b>Calculated:</b> -	<b>Data type:</b> Unsigned32 / FloatingPoint32
<b>Description:</b>	<b>Can be changed:</b> T	<b>Scaling:</b> p2000	<b>Dynamic index:</b> CDS, p0170
	<b>Unit group:</b> -	<b>Unit selection:</b> -	<b>Function diagram:</b> 3001, 3030
<b>Dependency:</b>	<b>Min:</b> -	<b>Max:</b> -	<b>Factory setting:</b> [0] 2050[1] 0 [2] 0 [3] 0
	Sets the signal source for the main setpoint. Examples: r1024: Fixed speed setpoint effective r1050: Motor. potentiometer setpoint after the ramp-function generator		
See also: p1071, r1073, r1078			

**NOTICE**

The parameter may be protected as a result of p0922 or p2079 and cannot be changed.

<b>p1071[0...n]</b>	<b>CI: Main setpoint scaling / Main setp scal</b>		
	<b>Access level:</b> 3	<b>Calculated:</b> -	<b>Data type:</b> Unsigned32 / FloatingPoint32
<b>Description:</b>	<b>Can be changed:</b> T	<b>Scaling:</b> PERCENT	<b>Dynamic index:</b> CDS, p0170
	<b>Unit group:</b> -	<b>Unit selection:</b> -	<b>Function diagram:</b> 3001, 3030
<b>Dependency:</b>	<b>Min:</b> -	<b>Max:</b> -	<b>Factory setting:</b> 1
	Sets the signal source for scaling the main setpoint.		

<b>r1073</b>	<b>CO: Main setpoint effective / Main setpoint eff</b>		
	<b>Access level:</b> 3	<b>Calculated:</b> -	<b>Data type:</b> FloatingPoint32
<b>Description:</b>	<b>Can be changed:</b> -	<b>Scaling:</b> p2000	<b>Dynamic index:</b> -
	<b>Unit group:</b> 3_1	<b>Unit selection:</b> p0505	<b>Function diagram:</b> 3030
<b>Dependency:</b>	<b>Min:</b> - [rpm]	<b>Max:</b> - [rpm]	<b>Factory setting:</b> - [rpm]
	Displays the effective main setpoint. The value shown is the main setpoint after scaling.		

---

<b>p1075[0...n]</b>	<b>CI: Supplementary setp / Suppl setp</b>		
	<b>Access level:</b> 3	<b>Calculated:</b> -	<b>Data type:</b> Unsigned32 / FloatingPoint32
	<b>Can be changed:</b> T	<b>Scaling:</b> p2000	<b>Dynamic index:</b> CDS, p0170
	<b>Unit group:</b> -	<b>Unit selection:</b> -	<b>Function diagram:</b> 3001, 3030
	<b>Min:</b> -	<b>Max:</b> -	<b>Factory setting:</b> 0

**Description:** Sets the signal source for the supplementary setpoint.  
**Dependency:** See also: p1076, r1077, r1078

---

<b>p1076[0...n]</b>	<b>CI: Supplementary setpoint scaling / Suppl setp scal</b>		
	<b>Access level:</b> 3	<b>Calculated:</b> -	<b>Data type:</b> Unsigned32 / FloatingPoint32
	<b>Can be changed:</b> T	<b>Scaling:</b> PERCENT	<b>Dynamic index:</b> CDS, p0170
	<b>Unit group:</b> -	<b>Unit selection:</b> -	<b>Function diagram:</b> 3001, 3030
	<b>Min:</b> -	<b>Max:</b> -	<b>Factory setting:</b> 1

**Description:** Sets the signal source for scaling the supplementary setpoint.

---

<b>r1077</b>	<b>CO: Supplementary setpoint effective / Suppl setpoint eff</b>		
	<b>Access level:</b> 3	<b>Calculated:</b> -	<b>Data type:</b> FloatingPoint32
	<b>Can be changed:</b> -	<b>Scaling:</b> p2000	<b>Dynamic index:</b> -
	<b>Unit group:</b> 3_1	<b>Unit selection:</b> p0505	<b>Function diagram:</b> 3030
	<b>Min:</b> - [rpm]	<b>Max:</b> - [rpm]	<b>Factory setting:</b> - [rpm]

**Description:** Displays the effective supplementary setpoint. The value shown is the additional setpoint after scaling.

---

<b>r1078</b>	<b>CO: Total setpoint effective / Total setpoint eff</b>		
	<b>Access level:</b> 3	<b>Calculated:</b> -	<b>Data type:</b> FloatingPoint32
	<b>Can be changed:</b> -	<b>Scaling:</b> p2000	<b>Dynamic index:</b> -
	<b>Unit group:</b> 3_1	<b>Unit selection:</b> p0505	<b>Function diagram:</b> 3030
	<b>Min:</b> - [rpm]	<b>Max:</b> - [rpm]	<b>Factory setting:</b> - [rpm]

**Description:** Displays the total effective setpoint.  
The value indicates the sum of the effective main setpoint and supplementary setpoint.

---

**Note**

If the fixed speed setpoint is the source for the speed setpoint, then when the extended service mode is activated (r3889.0 = 1) fixed speed setpoint 15 is displayed.

---

<b>p1079</b>	<b>Interpolator clock cycle for speed setpoints / Interp_cyc n_set</b>		
	<b>Access level:</b> 3	<b>Calculated:</b> CALC_MOD_ALL	<b>Data type:</b> FloatingPoint32
	<b>Can be changed:</b> T, U	<b>Scaling:</b> -	<b>Dynamic index:</b> -
	<b>Unit group:</b> -	<b>Unit selection:</b> -	<b>Function diagram:</b> -
	<b>Min:</b> 0.00 [ms]	<b>Max:</b> 127.00 [ms]	<b>Factory setting:</b> 0.00 [ms]

**Description:** Sets the time with which new speed setpoints are interpolated.  
With interpolation, the higher-level control adapts the speed setpoint steps to the time grid of the setpoint channel.

---



**Recommendation:** For non-synchronous operation, a setting to the maximum time difference between two setpoints is recommended. For sensorless vector control, interpolation should always be activated if the ramp-up and ramp-down times of the ramp-function generator are very short. The drive must be able to follow the external speed setpoint (the drive does not ramp up at the torque limit).

**Note**

For acceleration precontrol of the speed controller, interpolation prevents torque peaks from occurring if the ramp-up or ramp-down times in the setpoint channel are zero.

When exiting commissioning, the parameter is preset using the automatic calculation if, as setpoint source for the main or supplementary setpoint, a PZD receive word is already set and the ramp-up time is zero.

Interpolation is limited to 127 cycles of the setpoint channel.

p1079 = 0 ms: interpolation is deactivated.

p1079 = 0.01 ms: the interpolation is automatically determined the first time that the speed setpoint is changed. After this, no other changes are made if the send times of the external control increase. Writing to p1079 again initiates the automatic adaptation of the interpolation time.

p1079 > 0.01 ms: interpolation is performed corresponding to the ratio to the computation clock cycle.

**p1080[0...n]****Minimum speed / n\_min**

**Access level:** 1

**Can be changed:** C2(1), T

**Unit group:** 3\_1

**Min:**

0.000 [rpm]

**Calculated:** -

**Scaling:** -

**Unit selection:** p0505

**Max:**

19500.000 [rpm]

**Data type:** FloatingPoint32

**Dynamic index:** DDS, p0180

**Function diagram:** 3050, 8022

**Factory setting:**

0.000 [rpm]

**Description:**

Sets the lowest possible motor speed.

This value is not undershot in operation.

**Dependency:**

See also: p1106

**⚠ WARNING**

The minimum speed is preassigned to 20% of the rated motor speed.

After all of the enable signal have been switched on, with the appropriate direction specified, the motor accelerates to this minimum speed.

**NOTICE**

The effective minimum speed is formed from p1080 and p1106.

**Note**

The parameter value applies for both motor directions.

In exceptional cases, the motor can operate below this value (e.g. when reversing).

**p1081****Maximum speed scaling / n\_max scal**

**Access level:** 2

**Can be changed:** T, U

**Unit group:** -

**Min:**

100.00 [%]

**Calculated:** -

**Scaling:** PERCENT

**Unit selection:** -

**Max:**

105.00 [%]

**Data type:** FloatingPoint32

**Dynamic index:** -

**Function diagram:** 3050, 3095

**Factory setting:**

100.00 [%]

**Description:**

Sets the scaling for the maximum speed (p1082).

For a higher-level speed control, this scaling allows the maximum speed to be briefly exceeded.

**Dependency:**

See also: p1082

**NOTICE**

Continuous operation above a scaling of 100 % is not permitted.

<b>p1082[0...n]</b>	<b>Maximum speed / n_max</b>		
	<b>Access level:</b> 1	<b>Calculated:</b> CALC_MOD_ALL	<b>Data type:</b> FloatingPoint32
	<b>Can be changed:</b> C2(1), T	<b>Scaling:</b> -	<b>Dynamic index:</b> DDS, p0180
	<b>Unit group:</b> 3_1	<b>Unit selection:</b> p0505	<b>Function diagram:</b> 3020, 3050, 3070
	<b>Min:</b> 0.000 [rpm]	<b>Max:</b> 210000.000 [rpm]	<b>Factory setting:</b> 1500.000 [rpm]
<b>Description:</b>	Sets the highest possible speed. Example: Induction motor p0310 = 50 / 60 Hz without output filter and Blocksize power unit p1082 <= 60 x 240 Hz / r0313 (vector control) p1082 <= 60 x 550 Hz / r0313 (U/f control)		
<b>Dependency:</b>	For vector control, the maximum speed is restricted to 60.0 / (8.333 x 500 μs x r0313). This can be identified by a reduction in r1084. p1082 is not changed in this process due to the fact that the operating mode p1300 can be changed over. If a sine-wave filter (p0230 = 3) is parameterized as output filter, then the maximum speed is limited corresponding to the maximum permissible filter output frequency (refer to the filter data sheet). When using sine-wave filters (p0230 = 3, 4), the maximum speed r1084 is limited to 70% of the resonant frequency of the filter capacitance and the motor leakage inductance. For reactors and dU/dt filters, it is limited to 120 Hz / r0313. See also: p0230, r0313, p0322		
<b>NOTICE</b> After the value has been modified, no further parameter modifications can be made and the status is shown in r3996. Modifications can be made again when r3996 = 0.			
<b>Note</b> The parameter applies for both motor directions. The parameter has a limiting effect and is the reference quantity for all ramp-up and ramp-down times (e.g. down ramps, ramp-function generator, motor potentiometer). The parameter is part of the quick commissioning (p0010 = 1); this means that it is appropriately pre-assigned when changing p0310, p0311, p0322. The following limits are always effective for p1082: p1082 <= 60 x minimum (15 x p0310, 550 Hz) / r0313 p1082 <= 60 x maximum power unit pulse frequency / (k x r0313), with k = 12 (vector control), k = 6.5 (U/f control) During automatic calculation (p0340 = 1, p3900 > 0), the parameter value is assigned the maximum motor speed (p0322). For p0322 = 0 the rated motor speed (p0311) is used as default (pre-assignment) value. For induction motors, the synchronous no-load speed is used as the default value (p0310 x 60 / r0313). For synchronous motors, the following additionally applies: During automatic calculation (p0340, p3900), p1082 is limited to speeds where the EMF does not exceed the DC link voltage. p1082 is also available in the quick commissioning (p0010 = 1); this means that when exiting via p3900 > 0, the value is not changed.			

<b>p1082[0...n]</b>	<b>Maximum speed / n_max</b>		
CUG120X_PN (PM330)	<b>Access level:</b> 1	<b>Calculated:</b> CALC_MOD_ALL	<b>Data type:</b> FloatingPoint32
	<b>Can be changed:</b> C2(1), T	<b>Scaling:</b> -	<b>Dynamic index:</b> DDS, p0180
	<b>Unit group:</b> 3_1	<b>Unit selection:</b> p0505	<b>Function diagram:</b> 3020, 3050, 3070
	<b>Min:</b> 0.000 [rpm]	<b>Max:</b> 210000.000 [rpm]	<b>Factory setting:</b> 1500.000 [rpm]
<b>Description:</b>	Sets the highest possible speed setpoint.		
<b>Dependency:</b>	The maximum speed is limited to: p1082 <= 60 x 150 Hz / r0313 See also: p0230, p0310, r0313, p0322		

<b>NOTICE</b>
After the value has been modified, no further parameter modifications can be made and the status is shown in r3996. Modifications can be made again when r3996 = 0.

**Note**

The parameter applies for both motor directions.

The parameter has a limiting effect and is the reference quantity for all ramp-up and ramp-down times (e.g. down ramps, ramp-function generator, motor potentiometer).

The parameter is part of the quick commissioning (p0010 = 1); this means that it is appropriately pre-assigned when changing p0310, p0311 and p0322 (p0310 x 60 / r0313, for p0322 = 0).

<b>p1083[0...n]</b>	<b>CO: Speed limit in positive direction of rotation / n_limit pos</b>		
	<b>Access level:</b> 3	<b>Calculated:</b> -	<b>Data type:</b> FloatingPoint32
	<b>Can be changed:</b> T, U	<b>Scaling:</b> p2000	<b>Dynamic index:</b> DDS, p0180
	<b>Unit group:</b> 3_1	<b>Unit selection:</b> p0505	<b>Function diagram:</b> 3050
	<b>Min:</b> 0.000 [rpm]	<b>Max:</b> 210000.000 [rpm]	<b>Factory setting:</b> 210000.000 [rpm]
<b>Description:</b>	Sets the maximum speed for the positive direction.		
	<b>NOTICE</b>		
	A BICO interconnection to a parameter that belongs to a drive data set always acts on the effective data set.		

<b>r1084</b>	<b>CO: Speed limit positive effective / n_limit pos eff</b>		
	<b>Access level:</b> 3	<b>Calculated:</b> -	<b>Data type:</b> FloatingPoint32
	<b>Can be changed:</b> -	<b>Scaling:</b> p2000	<b>Dynamic index:</b> -
	<b>Unit group:</b> 3_1	<b>Unit selection:</b> p0505	<b>Function diagram:</b> 3050, 7958
	<b>Min:</b> - [rpm]	<b>Max:</b> - [rpm]	<b>Factory setting:</b> - [rpm]
<b>Description:</b>	Display and connector output for the active positive speed limit.		
<b>Dependency:</b>	See also: p1082, p1083, p1085		
	<b>Note</b>		
	Vector control: r1084 <= 60 x 240 Hz / r0313		

<b>p1085[0...n]</b>	<b>CI: Speed limit in positive direction of rotation / n_limit pos</b>		
	<b>Access level:</b> 3	<b>Calculated:</b> -	<b>Data type:</b> Unsigned32 / FloatingPoint32
	<b>Can be changed:</b> T	<b>Scaling:</b> p2000	<b>Dynamic index:</b> CDS, p0170
	<b>Unit group:</b> -	<b>Unit selection:</b> -	<b>Function diagram:</b> 3050
	<b>Min:</b> -	<b>Max:</b> -	<b>Factory setting:</b> 1083[0]
<b>Description:</b>	Sets the signal source for the speed limit of the positive direction.		

<b>p1086[0...n]</b>	<b>CO: Speed limit in negative direction of rotation / n_limit neg</b>		
	<b>Access level:</b> 3	<b>Calculated:</b> -	<b>Data type:</b> FloatingPoint32
	<b>Can be changed:</b> T, U	<b>Scaling:</b> p2000	<b>Dynamic index:</b> DDS, p0180
	<b>Unit group:</b> 3_1	<b>Unit selection:</b> p0505	<b>Function diagram:</b> 3050
	<b>Min:</b> -210000.000 [rpm]	<b>Max:</b> 0.000 [rpm]	<b>Factory setting:</b> -210000.000 [rpm]
<b>Description:</b>	Sets the speed limit for the negative direction.		

7.3 Parameter list

<b>NOTICE</b>
A BICO interconnection to a parameter that belongs to a drive data set always acts on the effective data set.

<b>r1087</b>	<b>CO: Speed limit negative effective / n_limit neg eff</b>		
	<b>Access level:</b> 3	<b>Calculated:</b> -	<b>Data type:</b> FloatingPoint32
	<b>Can be changed:</b> -	<b>Scaling:</b> p2000	<b>Dynamic index:</b> -
	<b>Unit group:</b> 3_1	<b>Unit selection:</b> p0505	<b>Function diagram:</b> 3050, 7958
	<b>Min:</b> - [rpm]	<b>Max:</b> - [rpm]	<b>Factory setting:</b> - [rpm]
<b>Description:</b>	Display and connector output for the active negative speed limit.		
<b>Dependency:</b>	See also: p1082, p1086, p1088		
	<b>Note</b> Vector control: r1087 >= -60 x 240 Hz / r0313		

<b>p1088[0...n]</b>	<b>CI: Speed limit in negative direction of rotation / n_limit neg</b>		
	<b>Access level:</b> 3	<b>Calculated:</b> -	<b>Data type:</b> Unsigned32 / FloatingPoint32
	<b>Can be changed:</b> T	<b>Scaling:</b> p2000	<b>Dynamic index:</b> CDS, p0170
	<b>Unit group:</b> -	<b>Unit selection:</b> -	<b>Function diagram:</b> 3050
	<b>Min:</b> -	<b>Max:</b> -	<b>Factory setting:</b> 1086[0]
<b>Description:</b>	Sets the signal source for the speed/velocity limit of the negative direction.		

<b>p1091[0...n]</b>	<b>Skip speed 1 / n_skip 1</b>		
	<b>Access level:</b> 3	<b>Calculated:</b> -	<b>Data type:</b> FloatingPoint32
	<b>Can be changed:</b> T, U	<b>Scaling:</b> p2000	<b>Dynamic index:</b> DDS, p0180
	<b>Unit group:</b> 3_1	<b>Unit selection:</b> p0505	<b>Function diagram:</b> 3050
	<b>Min:</b> 0.000 [rpm]	<b>Max:</b> 210000.000 [rpm]	<b>Factory setting:</b> 0.000 [rpm]
<b>Description:</b>	Sets skip speed 1.		
<b>Dependency:</b>	See also: p1092, p1093, p1094, p1101		

<b>NOTICE</b>
Skip bandwidths can also become ineffective as a result of the downstream limits in the setpoint channel.

**Note**  
The skip (suppression) speeds can be used to prevent the effects of mechanical resonance.

<b>p1092[0...n]</b>	<b>Skip speed 2 / n_skip 2</b>		
	<b>Access level:</b> 3	<b>Calculated:</b> -	<b>Data type:</b> FloatingPoint32
	<b>Can be changed:</b> T, U	<b>Scaling:</b> p2000	<b>Dynamic index:</b> DDS, p0180
	<b>Unit group:</b> 3_1	<b>Unit selection:</b> p0505	<b>Function diagram:</b> 3050
	<b>Min:</b> 0.000 [rpm]	<b>Max:</b> 210000.000 [rpm]	<b>Factory setting:</b> 0.000 [rpm]
<b>Description:</b>	Sets skip speed 2.		
<b>Dependency:</b>	See also: p1091, p1093, p1094, p1101		

<b>NOTICE</b>
Skip bandwidths can also become ineffective as a result of the downstream limits in the setpoint channel.

<b>p1093[0...n]</b>	<b>Skip speed 3 / n_skip 3</b>			
	<b>Access level:</b> 3	<b>Calculated:</b> -	<b>Data type:</b> FloatingPoint32	
	<b>Can be changed:</b> T, U	<b>Scaling:</b> p2000	<b>Dynamic index:</b> DDS, p0180	
	<b>Unit group:</b> 3_1	<b>Unit selection:</b> p0505	<b>Function diagram:</b> 3050	
	<b>Min:</b> 0.000 [rpm]	<b>Max:</b> 210000.000 [rpm]	<b>Factory setting:</b> 0.000 [rpm]	
<b>Description:</b>	Sets skip speed 3.			
<b>Dependency:</b>	See also: p1091, p1092, p1094, p1101			
	<b>NOTICE</b>			
	Skip bandwidths can also become ineffective as a result of the downstream limits in the setpoint channel.			
<b>p1094[0...n]</b>	<b>Skip speed 4 / n_skip 4</b>			
	<b>Access level:</b> 3	<b>Calculated:</b> -	<b>Data type:</b> FloatingPoint32	
	<b>Can be changed:</b> T, U	<b>Scaling:</b> p2000	<b>Dynamic index:</b> DDS, p0180	
	<b>Unit group:</b> 3_1	<b>Unit selection:</b> p0505	<b>Function diagram:</b> 3050	
	<b>Min:</b> 0.000 [rpm]	<b>Max:</b> 210000.000 [rpm]	<b>Factory setting:</b> 0.000 [rpm]	
<b>Description:</b>	Sets skip speed 4.			
<b>Dependency:</b>	See also: p1091, p1092, p1093, p1101			
	<b>NOTICE</b>			
	Skip bandwidths can also become ineffective as a result of the downstream limits in the setpoint channel.			
<b>p1098[0...n]</b>	<b>CI: Skip speed scaling / n_skip scal</b>			
	<b>Access level:</b> 3	<b>Calculated:</b> -	<b>Data type:</b> Unsigned32 / FloatingPoint32	
	<b>Can be changed:</b> T	<b>Scaling:</b> PERCENT	<b>Dynamic index:</b> CDS, p0170	
	<b>Unit group:</b> -	<b>Unit selection:</b> -	<b>Function diagram:</b> 3050	
	<b>Min:</b> -	<b>Max:</b> -	<b>Factory setting:</b> 1	
<b>Description:</b>	Sets the signal source for scaling the skip speeds.			
<b>Dependency:</b>	See also: p1091, p1092, p1093, p1094			
<b>r1099.0</b>	<b>CO/BO: Skip band status word / Skip band ZSW</b>			
	<b>Access level:</b> 3	<b>Calculated:</b> -	<b>Data type:</b> Unsigned32	
	<b>Can be changed:</b> -	<b>Scaling:</b> -	<b>Dynamic index:</b> -	
	<b>Unit group:</b> -	<b>Unit selection:</b> -	<b>Function diagram:</b> -	
	<b>Min:</b> -	<b>Max:</b> -	<b>Factory setting:</b> -	
<b>Description:</b>	Display and BICO output for the skip bands.			
<b>Bit field:</b>	<b>Bit</b>	<b>Signal name</b>	<b>1 signal</b>	<b>0 signal</b>
	00	r1170 within the skip band	Yes	No
<b>Dependency:</b>	See also: r1170			
	<b>Note</b>			
	For bit 00:			
	With the bit set, the setpoint speed is within the skip band after the ramp-function generator (r1170).			
	The signal can be used to switch over the drive data set (DDS).			

7.3 Parameter list

<b>p1101[0...n]</b>	<b>Skip speed bandwidth / n_skip bandwidth</b>		
	<b>Access level:</b> 3	<b>Calculated:</b> -	<b>Data type:</b> FloatingPoint32
<b>Description:</b>	<b>Can be changed:</b> T, U	<b>Scaling:</b> p2000	<b>Dynamic index:</b> DDS, p0180
	<b>Unit group:</b> 3_1	<b>Unit selection:</b> p0505	<b>Function diagram:</b> 3050
<b>Dependency:</b>	<b>Min:</b> 0.000 [rpm]	<b>Max:</b> 210000.000 [rpm]	<b>Factory setting:</b> 0.000 [rpm]
	Sets the bandwidth for the skip speeds/velocities 1 to 4.		
See also: p1091, p1092, p1093, p1094			

**Note**  
 The setpoint (reference) speeds are skipped (suppressed) in the range of the skip speed +/-p1101. Steady-state operation is not possible in the skipped (suppressed) speed range. The skip (suppression) range is skipped.  
 Example:  
 p1091 = 600 and p1101 = 20  
 --> setpoint speeds between 580 and 620 [rpm] are skipped.  
 For the skip bandwidths, the following hysteresis behavior applies:  
 For a setpoint speed coming from below, the following applies:  
 r1170 < 580 [rpm] and 580 [rpm] <= r1114 <= 620 [rpm] --> r1119 = 580 [rpm]  
 For a setpoint speed coming from above, the following applies:  
 r1170 > 620 [rpm] and 580 [rpm] <= r1114 <= 620 [rpm] --> r1119 = 620 [rpm]

<b>p1106[0...n]</b>	<b>CI: Minimum speed signal source / n_min s_src</b>		
	<b>Access level:</b> 3	<b>Calculated:</b> -	<b>Data type:</b> Unsigned32 / FloatingPoint32
<b>Description:</b>	<b>Can be changed:</b> T	<b>Scaling:</b> p2000	<b>Dynamic index:</b> CDS, p0170
	<b>Unit group:</b> -	<b>Unit selection:</b> -	<b>Function diagram:</b> 3050
<b>Dependency:</b>	<b>Min:</b> -	<b>Max:</b> -	<b>Factory setting:</b> 0
	Sets the signal source for lowest possible motor speed.		
See also: p1080			

<b>NOTICE</b>
The effective minimum speed is formed from p1080 and p1106.

<b>p1110[0...n]</b>	<b>BI: Inhibit negative direction / Inhib neg dir</b>		
	<b>Access level:</b> 3	<b>Calculated:</b> -	<b>Data type:</b> Unsigned32 / Binary
<b>Description:</b>	<b>Can be changed:</b> T	<b>Scaling:</b> -	<b>Dynamic index:</b> CDS, p0170
	<b>Unit group:</b> -	<b>Unit selection:</b> -	<b>Function diagram:</b> 2505, 3040
<b>Dependency:</b>	<b>Min:</b> -	<b>Max:</b> -	<b>Factory setting:</b> 1
	Sets the signal source to disable the negative direction.		
See also: p1111			

<b>p1111[0...n]</b>	<b>BI: Inhibit positive direction / Inhib pos dir</b>		
	<b>Access level:</b> 3	<b>Calculated:</b> -	<b>Data type:</b> Unsigned32 / Binary
<b>Description:</b>	<b>Can be changed:</b> T	<b>Scaling:</b> -	<b>Dynamic index:</b> CDS, p0170
	<b>Unit group:</b> -	<b>Unit selection:</b> -	<b>Function diagram:</b> 2505, 3040
<b>Dependency:</b>	<b>Min:</b> -	<b>Max:</b> -	<b>Factory setting:</b> 0
	Sets the signal source to disable the positive direction.		
See also: p1110			

<b>p1113[0...n]</b>	<b>BI: Setpoint inversion / Setp inv</b>		
	<b>Access level:</b> 3	<b>Calculated:</b> -	<b>Data type:</b> Unsigned32 / Binary
	<b>Can be changed:</b> T	<b>Scaling:</b> -	<b>Dynamic index:</b> CDS, p0170
	<b>Unit group:</b> -	<b>Unit selection:</b> -	<b>Function diagram:</b> 2441, 2442, 2505, 3040
	<b>Min:</b> -	<b>Max:</b> -	<b>Factory setting:</b> [0] 2090.11 [1] 0 [2] 0 [3] 0

**Description:** Sets the signal source to invert the setpoint.

**Dependency:** See also: r1198

**CAUTION**

If the technology controller is being used as the speed main setpoint (p2251 = 0), do not invert the setpoint using p1113 when the technology controller is enabled because this can cause the speed to change suddenly and lead to positive couplings in the control loop.

**NOTICE**

The parameter may be protected as a result of p0922 or p2079 and cannot be changed.

<b>r1114</b>	<b>CO: Setpoint after the direction limiting / Setp after limit</b>		
	<b>Access level:</b> 3	<b>Calculated:</b> -	<b>Data type:</b> FloatingPoint32
	<b>Can be changed:</b> -	<b>Scaling:</b> p2000	<b>Dynamic index:</b> -
	<b>Unit group:</b> 3_1	<b>Unit selection:</b> p0505	<b>Function diagram:</b> 3001, 3040, 3050
	<b>Min:</b> - [rpm]	<b>Max:</b> - [rpm]	<b>Factory setting:</b> - [rpm]

**Description:** Displays the speed/velocity setpoint after the changeover and limiting the direction.

<b>r1119</b>	<b>CO: Ramp-function generator setpoint at the input / RFG setp at inp</b>		
	<b>Access level:</b> 3	<b>Calculated:</b> -	<b>Data type:</b> FloatingPoint32
	<b>Can be changed:</b> -	<b>Scaling:</b> p2000	<b>Dynamic index:</b> -
	<b>Unit group:</b> 3_1	<b>Unit selection:</b> p0505	<b>Function diagram:</b> 3050, 3070, 6300, 8022
	<b>Min:</b> - [rpm]	<b>Max:</b> - [rpm]	<b>Factory setting:</b> - [rpm]

**Description:** Displays the setpoint at the input of the ramp-function generator.

**NOTICE**

The parameter may be protected as a result of p0922 or p2079 and cannot be changed.

**Note**

The setpoint is influenced by other functions, e.g. skip (suppressed) speeds, minimum and maximum limits.

<b>p1120[0...n]</b>	<b>Ramp-function generator ramp-up time / RFG ramp-up time</b>		
	<b>Access level:</b> 1	<b>Calculated:</b> -	<b>Data type:</b> FloatingPoint32
	<b>Can be changed:</b> C2(1), T, U	<b>Scaling:</b> -	<b>Dynamic index:</b> DDS, p0180
	<b>Unit group:</b> -	<b>Unit selection:</b> -	<b>Function diagram:</b> 3070
	<b>Min:</b> 0.000 [s]	<b>Max:</b> 999999.000 [s]	<b>Factory setting:</b> 10.000 [s]

**Description:** The ramp-function generator ramps-up the speed setpoint from standstill (setpoint = 0) up to the maximum speed (p1082) in this time.

## 7.3 Parameter list

**Dependency:** See also: p1082

**Note**

The ramp-up time can be scaled via connector input p1138.

The parameter is adapted during the rotating measurement (p1960 > 0). This is the reason that during the rotating measurement, the motor can accelerate faster than was originally parameterized.

For U/f control and sensorless vector control (see p1300), a ramp-up time of 0 s does not make sense. The setting should be based on the startup times (r0345) of the motor.

**p1120[0...n] Ramp-function generator ramp-up time / RFG ramp-up time**

CUG120X\_PN  
(PM330)

**Access level:** 1

**Calculated:** -

**Data type:** FloatingPoint32

**Can be changed:** C2(1), T, U

**Scaling:** -

**Dynamic index:** DDS, p0180

**Unit group:** -

**Unit selection:** -

**Function diagram:** 3070

**Min:**

**Max:**

**Factory setting:**

0.000 [s]

999999.000 [s]

20.000 [s]

**Description:** The ramp-function generator ramps-up the speed setpoint from standstill (setpoint = 0) up to the maximum speed (p1082) in this time.

**Dependency:** See also: p1082

**Note**

The ramp-up time can be scaled via connector input p1138.

The parameter is adapted during the rotating measurement (p1960 > 0). This is the reason that during the rotating measurement, the motor can accelerate faster than was originally parameterized.

For U/f control and sensorless vector control (see p1300), a ramp-up time of 0 s does not make sense. The setting should be based on the startup times (r0345) of the motor.

**p1121[0...n] Ramp-function generator ramp-down time / RFG ramp-down time**

**Access level:** 1

**Calculated:** -

**Data type:** FloatingPoint32

**Can be changed:** C2(1), T, U

**Scaling:** -

**Dynamic index:** DDS, p0180

**Unit group:** -

**Unit selection:** -

**Function diagram:** 3070

**Min:**

**Max:**

**Factory setting:**

0.000 [s]

999999.000 [s]

10.000 [s]

**Description:** Sets the ramp-down time for the ramp-function generator.

The ramp-function generator ramps-down the speed setpoint from the maximum speed (p1082) down to standstill (setpoint = 0) in this time.

Further, the ramp-down time is always effective for OFF1.

**Dependency:** See also: p1082, p1127

**Note**

For U/f control and sensorless vector control (see p1300), a ramp-down time of 0 s does not make sense. The setting should be based on the startup times (r0345) of the motor.

**p1121[0...n] Ramp-function generator ramp-down time / RFG ramp-down time**

CUG120X\_PN  
(PM330)

**Access level:** 1

**Calculated:** -

**Data type:** FloatingPoint32

**Can be changed:** C2(1), T, U

**Scaling:** -

**Dynamic index:** DDS, p0180

**Unit group:** -

**Unit selection:** -

**Function diagram:** 3070

**Min:**

**Max:**

**Factory setting:**

0.000 [s]

999999.000 [s]

30.000 [s]

**Description:** Sets the ramp-down time for the ramp-function generator.

The ramp-function generator ramps-down the speed setpoint from the maximum speed (p1082) down to standstill (setpoint = 0) in this time.

Further, the ramp-down time is always effective for OFF1.

**Dependency:** The parameter is pre-assigned depending on the size of the power unit.

See also: p1082, p1127



**Note**

For U/f control and sensorless vector control (see p1300), a ramp-down time of 0 s does not make sense. The setting should be based on the startup times (r0345) of the motor.

**p1127[0...n]****Ramp-function generator minimum ramp-down time / RFG t<sub>RD</sub> min****Access level:** 3**Calculated:** CALC\_MOD\_ALL **Data type:** FloatingPoint32**Can be changed:** T, U**Scaling:** -**Dynamic index:** DDS, p0180**Unit group:** -**Unit selection:** -**Function diagram:** -**Min:****Max:****Factory setting:**

0.000 [s]

999999.000 [s]

0.000 [s]

**Description:**

Sets the minimum ramp-down time.

The ramp-down time (p1121) is limited internally to this minimum value.

The parameter cannot be set shorter than the minimum ramp-up time (p1123).

**Dependency:**

See also: p1082

**Note**

For U/f control and sensorless vector control (see p1300), a ramp-down time of 0 s does not make sense. The setting should be based on the startup times (r0345) of the motor.

If the maximum speed p1082 changes, p1127 is re-calculated.

**p1130[0...n]****Ramp-function generator initial rounding-off time / RFG t<sub>start\_round</sub>****Access level:** 2**Calculated:** -**Data type:** FloatingPoint32**Can be changed:** T, U**Scaling:** -**Dynamic index:** DDS, p0180**Unit group:** -**Unit selection:** -**Function diagram:** 3070**Min:****Max:****Factory setting:**

0.000 [s]

30.000 [s]

0.000 [s]

**Description:**

Sets the initial rounding-off time for the extended ramp generator. The value applies to ramp-up and ramp-down.

**Note**

Rounding-off times avoid an abrupt response and prevent damage to the mechanical system.

Rounding off is not active if the technology controller is used as main speed setpoint (p2251 = 0).

**p1130[0...n]****Ramp-function generator initial rounding-off time / RFG t<sub>start\_round</sub>**CUG120X\_PN  
(PM330)**Access level:** 2**Calculated:** -**Data type:** FloatingPoint32**Can be changed:** T, U**Scaling:** -**Dynamic index:** DDS, p0180**Unit group:** -**Unit selection:** -**Function diagram:** 3070**Min:****Max:****Factory setting:**

0.000 [s]

30.000 [s]

2.000 [s]

**Description:**

Sets the initial rounding-off time for the extended ramp generator. The value applies to ramp-up and ramp-down.

**Note**

Rounding-off times avoid an abrupt response and prevent damage to the mechanical system.

Rounding off is not active if the technology controller is used as main speed setpoint (p2251 = 0).

**p1131[0...n]****Ramp-function generator final rounding-off time / RFG t<sub>end\_delay</sub>****Access level:** 2**Calculated:** -**Data type:** FloatingPoint32**Can be changed:** T, U**Scaling:** -**Dynamic index:** DDS, p0180**Unit group:** -**Unit selection:** -**Function diagram:** 3070**Min:****Max:****Factory setting:**

0.000 [s]

30.000 [s]

0.000 [s]

**Description:**

Sets the final rounding-off time for the extended ramp generator.

The value applies to ramp-up and ramp-down.

**Note**

Rounding-off times avoid an abrupt response and prevent damage to the mechanical system.  
Rounding off is not active if the technology controller is used as main speed setpoint (p2251 = 0).

**p1131[0...n]**

CUG120X\_PN  
(PM330)

**Ramp-function generator final rounding-off time / RFG t\_end\_delay****Access level:** 2**Calculated:** -**Data type:** FloatingPoint32**Can be changed:** T, U**Scaling:** -**Dynamic index:** DDS, p0180**Unit group:** -**Unit selection:** -**Function diagram:** 3070**Min:****Max:****Factory setting:**

0.000 [s]

30.000 [s]

3.000 [s]

**Description:**

Sets the final rounding-off time for the extended ramp generator.  
The value applies to ramp-up and ramp-down.

**Note**

Rounding-off times avoid an abrupt response and prevent damage to the mechanical system.  
Rounding off is not active if the technology controller is used as main speed setpoint (p2251 = 0).

**p1134[0...n]****Ramp-function generator rounding-off type / RFG round-off type****Access level:** 2**Calculated:** -**Data type:** Integer16**Can be changed:** T, U**Scaling:** -**Dynamic index:** DDS, p0180**Unit group:** -**Unit selection:** -**Function diagram:** 3070**Min:****Max:****Factory setting:**

0

1

0

**Description:**

Sets the smoothed response to the OFF1 command or the reduced setpoint for the extended ramp-function generator.

**Value:**

0: Continuous smoothing

1: Discontinuous smoothing

**Dependency:**

No effect up to initial rounding-off time (p1130) > 0 s.

**Note**

p1134 = 0 (continuous smoothing)

If the setpoint is reduced while ramping-up, initially a final rounding-off is carried out and then the ramp-up completed. During the final rounding-off, the output of the ramp-function generator continues to go in the direction of the previous setpoint (overshoot). After the final rounding-off has been completed, the output goes toward the new setpoint.

p1134 = 1 (discontinuous smoothing)

If the setpoint is reduced while ramping-up, then the output goes immediately in the direction of the new setpoint. For the setpoint change there is no rounding-off.

**p1135[0...n]****OFF3 ramp-down time / OFF3 t\_RD****Access level:** 2**Calculated:** -**Data type:** FloatingPoint32**Can be changed:** C2(1), T, U**Scaling:** -**Dynamic index:** DDS, p0180**Unit group:** -**Unit selection:** -**Function diagram:** 3070**Min:****Max:****Factory setting:**

0.000 [s]

5400.000 [s]

0.000 [s]

**Description:**

Sets the ramp-down time from the maximum speed down to zero speed for the OFF3 command.

**Note**

This time can be exceeded if the DC link voltage reaches its maximum value.

<b>p1135[0...n]</b> CUG120X_PN (PM330)	<b>OFF3 ramp-down time / OFF3 t_RD</b> <b>Access level:</b> 2 <b>Can be changed:</b> C2(1), T, U <b>Unit group:</b> - <b>Min:</b> 0.000 [s]	<b>Calculated:</b> - <b>Scaling:</b> - <b>Unit selection:</b> - <b>Max:</b> 5400.000 [s]	<b>Data type:</b> FloatingPoint32 <b>Dynamic index:</b> DDS, p0180 <b>Function diagram:</b> 3070 <b>Factory setting:</b> 3.000 [s]
<b>Description:</b>	Sets the ramp-down time from the maximum speed down to zero speed for the OFF3 command.		
<b>Dependency:</b>	The parameter is pre-assigned depending on the size of the power unit.		

**Note**

This time can be exceeded if the DC link voltage reaches its maximum value.

<b>p1136[0...n]</b>	<b>OFF3 initial rounding-off time / RFGOFF3 t_strt_rnd</b> <b>Access level:</b> 3 <b>Can be changed:</b> T, U <b>Unit group:</b> - <b>Min:</b> 0.000 [s]	<b>Calculated:</b> - <b>Scaling:</b> - <b>Unit selection:</b> - <b>Max:</b> 30.000 [s]	<b>Data type:</b> FloatingPoint32 <b>Dynamic index:</b> DDS, p0180 <b>Function diagram:</b> 3070 <b>Factory setting:</b> 0.000 [s]
<b>Description:</b>	Sets the initial rounding-off time for OFF3 for the extended ramp generator.		

<b>p1136[0...n]</b> CUG120X_PN (PM330)	<b>OFF3 initial rounding-off time / RFGOFF3 t_strt_rnd</b> <b>Access level:</b> 3 <b>Can be changed:</b> T, U <b>Unit group:</b> - <b>Min:</b> 0.000 [s]	<b>Calculated:</b> - <b>Scaling:</b> - <b>Unit selection:</b> - <b>Max:</b> 30.000 [s]	<b>Data type:</b> FloatingPoint32 <b>Dynamic index:</b> DDS, p0180 <b>Function diagram:</b> 3070 <b>Factory setting:</b> 0.500 [s]
<b>Description:</b>	Sets the initial rounding-off time for OFF3 for the extended ramp generator.		

<b>p1137[0...n]</b>	<b>OFF3 final rounding-off time / RFG OFF3 t_end_del</b> <b>Access level:</b> 3 <b>Can be changed:</b> T, U <b>Unit group:</b> - <b>Min:</b> 0.000 [s]	<b>Calculated:</b> - <b>Scaling:</b> - <b>Unit selection:</b> - <b>Max:</b> 30.000 [s]	<b>Data type:</b> FloatingPoint32 <b>Dynamic index:</b> DDS, p0180 <b>Function diagram:</b> 3070 <b>Factory setting:</b> 0.000 [s]
<b>Description:</b>	Sets the final rounding-off time for OFF3 for the extended ramp generator.		

<b>p1138[0...n]</b>	<b>CI: Ramp-function generator ramp-up time scaling / RFG t_RU scal</b> <b>Access level:</b> 3 <b>Can be changed:</b> T <b>Unit group:</b> - <b>Min:</b> -	<b>Calculated:</b> - <b>Scaling:</b> PERCENT <b>Unit selection:</b> - <b>Max:</b> -	<b>Data type:</b> Unsigned32 / FloatingPoint32 <b>Dynamic index:</b> CDS, p0170 <b>Function diagram:</b> 3070 <b>Factory setting:</b> 1
<b>Description:</b>	Sets the signal source for scaling the ramp-up time of the ramp-function generator.		
<b>Dependency:</b>	See also: p1120		

**Note**

The ramp-up time is set in p1120.

7.3 Parameter list

<b>p1139[0...n]</b>	<b>CI: Ramp-function generator ramp-down time scaling / RFG t_RD scal</b>		
	<b>Access level:</b> 3	<b>Calculated:</b> -	<b>Data type:</b> Unsigned32 / FloatingPoint32
	<b>Can be changed:</b> T	<b>Scaling:</b> PERCENT	<b>Dynamic index:</b> CDS, p0170
	<b>Unit group:</b> -	<b>Unit selection:</b> -	<b>Function diagram:</b> 3070
	<b>Min:</b> -	<b>Max:</b> -	<b>Factory setting:</b> 1
<b>Description:</b>	Sets the signal source for scaling the ramp-down time of the ramp-function generator.		
<b>Dependency:</b>	See also: p1121		
	<b>Note</b> The ramp-down time is set in p1121.		

<b>p1140[0...n]</b>	<b>BI: Enable ramp-function generator/inhibit ramp-function generator / Enable RFG</b>		
	<b>Access level:</b> 3	<b>Calculated:</b> -	<b>Data type:</b> Unsigned32 / Binary
	<b>Can be changed:</b> T	<b>Scaling:</b> -	<b>Dynamic index:</b> CDS, p0170
	<b>Unit group:</b> -	<b>Unit selection:</b> -	<b>Function diagram:</b> 2501
	<b>Min:</b> -	<b>Max:</b> -	<b>Factory setting:</b> [0] 2090.4 [1] 1 [2] 2090.4 [3] 2090.4
<b>Description:</b>	Sets the signal source for the command "enable ramp-function generator/inhibit ramp-function generator". For the PROFIdrive profile, this command corresponds to control word 1 bit 4 (STW1.4). BI: p1140 = 0 signal: Inhibits the ramp-function generator (the ramp-function generator output is set to zero). BI: p1140 = 1 signal: Enable ramp-function generator.		
<b>Dependency:</b>	See also: r0054, p1141, p1142		

<b>⚠ CAUTION</b>
When "master control from PC" is activated, this binector input is ineffective.
<b>NOTICE</b>
The parameter may be protected as a result of p0922 or p2079 and cannot be changed.

<b>p1141[0...n]</b>	<b>BI: Continue ramp-function generator/freeze ramp-function generator / Continue RFG</b>		
	<b>Access level:</b> 3	<b>Calculated:</b> -	<b>Data type:</b> Unsigned32 / Binary
	<b>Can be changed:</b> T	<b>Scaling:</b> -	<b>Dynamic index:</b> CDS, p0170
	<b>Unit group:</b> -	<b>Unit selection:</b> -	<b>Function diagram:</b> 2501
	<b>Min:</b> -	<b>Max:</b> -	<b>Factory setting:</b> [0] 2090.5 [1] 1 [2] 2090.5 [3] 2090.5
<b>Description:</b>	Sets the signal source for the command "continue ramp-function generator/freeze ramp-function generator". For the PROFIdrive profile, this command corresponds to control word 1 bit 5 (STW1.5). BI: p1141 = 0 signal: Freezes the ramp-function generator. BI: p1141 = 1 signal: Continue ramp-function generator.		
<b>Dependency:</b>	See also: r0054, p1140, p1142		

<b>⚠ CAUTION</b>
When "master control from PC" is activated, this binector input is ineffective.
<b>NOTICE</b>
The ramp-function generator is, independent of the state of the signal source, active in the following cases: - OFF1/OFF3. - ramp-function generator output within the suppression bandwidth. - ramp-function generator output below the minimum speed.

<b>p1142[0...n]</b>	<b>BI: Enable setpoint/inhibit setpoint / Setpoint enable</b>		
	<b>Access level:</b> 3	<b>Calculated:</b> -	<b>Data type:</b> Unsigned32 / Binary
	<b>Can be changed:</b> T	<b>Scaling:</b> -	<b>Dynamic index:</b> CDS, p0170
	<b>Unit group:</b> -	<b>Unit selection:</b> -	<b>Function diagram:</b> 2501
	<b>Min:</b> -	<b>Max:</b> -	<b>Factory setting:</b> [0] 2090.6 [1] 1 [2] 2090.6 [3] 2090.6

**Description:** Sets the signal source for the command "enable setpoint/inhibit setpoint".  
For the PROFIdrive profile, this command corresponds to control word 1 bit 6 (STW1.6).  
BI: p1142 = 0 signal  
Inhibits the setpoint (the ramp-function generator input is set to zero).  
BI: p1142 = 1 signal  
Setpoint enable.

**Dependency:** See also: p1140, p1141

<b>⚠ CAUTION</b>
When "master control from PC" is activated, this binector input is ineffective.
<b>NOTICE</b>
The parameter may be protected as a result of p0922 or p2079 and cannot be changed.
<b>Note</b>
When the function module "position control" (r0108.3 = 1) is activated, this binector input is interconnected as follows as standard: BI: p1142 = 0 signal

<b>p1143[0...n]</b>	<b>BI: Ramp-function generator, accept setting value / RFG accept set v</b>		
	<b>Access level:</b> 3	<b>Calculated:</b> -	<b>Data type:</b> Unsigned32 / Binary
	<b>Can be changed:</b> T	<b>Scaling:</b> -	<b>Dynamic index:</b> CDS, p0170
	<b>Unit group:</b> -	<b>Unit selection:</b> -	<b>Function diagram:</b> 3070
	<b>Min:</b> -	<b>Max:</b> -	<b>Factory setting:</b> 29640.0

**Description:** Sets the signal source for accepting the setting value of the ramp-function generator.

**Dependency:** The signal source for the ramp-function generator setting value is set using parameters.  
See also: p1144

**Note**

0/1 signal:

The ramp-function generator output is immediately (without delay) set to the setting value of the ramp-function generator.

1 signal:

The setting value of the ramp-function generator is effective.

1/0 signal:

The input value of the ramp-function generator is effective. The ramp-function generator output is adapted to the input value using the ramp-up time or the ramp-down time.

0 signal:

The input value of the ramp-function generator is effective.

**p1144[0...n]****CI: Ramp-function generator setting value / RFG setting value****Access level:** 3**Calculated:** -**Data type:** Unsigned32 / FloatingPoint32**Can be changed:** T, U**Scaling:** p2000**Dynamic index:** CDS, p0170**Unit group:** -**Unit selection:** -**Function diagram:** 3070**Min:****Max:****Factory setting:**

-

-

29641[0]

**Description:**

Sets the signal source for the ramp-function generator setting value.

**Dependency:**

The signal source for accepting the setting value is set using parameters.

See also: p1143

**p1148[0...n]****Ramp-function gen. tolerance for ramp-up and ramp-down active / RFG tol HL/RL act****Access level:** 3**Calculated:** -**Data type:** FloatingPoint32**Can be changed:** T, U**Scaling:** -**Dynamic index:** DDS, p0180**Unit group:** 3\_1**Unit selection:** p0505**Function diagram:** 3070**Min:****Max:****Factory setting:**

0.000 [rpm]

1000.000 [rpm]

19.800 [rpm]

**Description:**

Sets the tolerance value for the status of the ramp-function generator (ramp-up active, ramp-down active).

If the input of the ramp-function generator does not change in comparison to the output by more than the entered tolerance time, then the status bits "ramp-up active" and "ramp-down active" are not influenced.

**r1149****CO: Ramp-function generator acceleration / RFG acceleration****Access level:** 3**Calculated:** -**Data type:** FloatingPoint32**Can be changed:** -**Scaling:** p2007**Dynamic index:** -**Unit group:** 39\_1**Unit selection:** p0505**Function diagram:** 3070**Min:****Max:****Factory setting:**- [rev/s<sup>2</sup>]- [rev/s<sup>2</sup>]- [rev/s<sup>2</sup>]**Description:**

Displays the acceleration of the ramp-function generator.

**r1170****CO: Speed controller setpoint sum / Speed setpoint sum****Access level:** 3**Calculated:** -**Data type:** FloatingPoint32**Can be changed:** -**Scaling:** p2000**Dynamic index:** -**Unit group:** 3\_1**Unit selection:** p0505**Function diagram:** 3001, 3080, 6300**Min:****Max:****Factory setting:**

- [rpm]

- [rpm]

- [rpm]

**Description:**

Display and connector output for the speed setpoint after selecting the ramp-function generator.

The value is the sum of speed setpoint 1 (p1155) and speed setpoint 2 (p1160).

<b>r1198.0...15</b>	<b>CO/BO: Control word setpoint channel / STW setpoint chan</b>			
	<b>Access level:</b> 3	<b>Calculated:</b> -	<b>Data type:</b> Unsigned16	
	<b>Can be changed:</b> -	<b>Scaling:</b> -	<b>Dynamic index:</b> -	
	<b>Unit group:</b> -	<b>Unit selection:</b> -	<b>Function diagram:</b> 2505	
	<b>Min:</b>	<b>Max:</b>	<b>Factory setting:</b>	
	-	-	-	
<b>Description:</b>	Display and BICO output for the control word of the setpoint channel.			
<b>Bit field:</b>	<b>Bit</b>	<b>Signal name</b>	<b>1 signal</b>	<b>0 signal</b>
	00	Fixed setpoint bit 0	Yes	No
	01	Fixed setpoint bit 1	Yes	No
	02	Fixed setpoint bit 2	Yes	No
	03	Fixed setpoint bit 3	Yes	No
	05	Inhibit negative direction	Yes	No
	06	Inhibit positive direction	Yes	No
	11	Setpoint inversion	Yes	No
	13	Motorized potentiometer raise	Yes	No
	14	Motorized potentiometer lower	Yes	No
	15	Bypass ramp-function generator	Yes	No
				FP
				3010
				3010
				3010
				3010
				3040
				3040
				3040
				3020
				3020
				3070
<b>p1200[0...n]</b>	<b>Flying restart operating mode / FlyRest op_mode</b>			
	<b>Access level:</b> 2	<b>Calculated:</b> -	<b>Data type:</b> Integer16	
	<b>Can be changed:</b> T, U	<b>Scaling:</b> -	<b>Dynamic index:</b> DDS, p0180	
	<b>Unit group:</b> -	<b>Unit selection:</b> -	<b>Function diagram:</b> 6300, 6850	
	<b>Min:</b>	<b>Max:</b>	<b>Factory setting:</b>	
	0	4	0	
<b>Description:</b>	Sets the operating mode for flying restart.			
	The flying restart allows the drive converter to be switched on while the motor is still rotating. In so doing, the drive converter output frequency is changed until the actual motor speed/velocity is found. The motor then accelerates up to the setpoint at the ramp-function generator setting.			
<b>Value:</b>	0: Flying restart inactive			
	1: Flying restart always active (start in setpoint direction)			
	4: Flying restart always active (start only in setpoint direction)			
<b>Dependency:</b>	A differentiation is made between flying restart for U/f control and for vector control (p1300).			
	Flying restart, U/f control: p1202, p1203, r1204			
	Flying restart, vector control: p1202, p1203, r1205			
	For synchronous motors, flying restart cannot be activated.			
	See also: p1201			
	See also: F07330, F07331			
	<b>NOTICE</b>			
	The "flying restart" function must be used in cases where the motor may still be running (e.g. after a brief line supply interruption) or is being driven by the load. The system might otherwise shut down as a result of overcurrent.			

7.3 Parameter list

**Note**

For p1200 = 1, 4, the following applies:

Flying restart is active after faults, OFF1, OFF2, OFF3.

For p1200 = 1, the following applies:

The search is made in both directions.

For p1200 = 4, the following applies:

The search is only made in the setpoint direction.

For U/f control (p1300 < 20), the following applies:

The speed can only be sensed for values above approx. 5 % of the rated motor speed. For lower speeds, it is assumed that the motor is at a standstill.

If p1200 is changed during commissioning (p0010 > 0), then it is possible that the old value will no longer be able to be set. The reason for this is that the dynamic limits of p1200 have been changed by a parameter that was set when the drive was commissioned (e.g. p0300).

**p1201[0...n]**

**BI: Flying restart enable signal source / Fly\_res enab S\_src**

**Access level:** 3

**Calculated:** -

**Data type:** Unsigned32 / Binary

**Can be changed:** T

**Scaling:** -

**Dynamic index:** CDS, p0170

**Unit group:** -

**Unit selection:** -

**Function diagram:** -

**Min:**

**Max:**

**Factory setting:**

-

-

1

**Description:**

Sets the signal source to enable the "flying restart" function.

**Dependency:**

See also: p1200

**Note**

Withdrawing the enable signal has the same effect as setting p1200 = 0.

**p1202[0...n]**

**Flying restart search current / FlyRest I\_srch**

**Access level:** 3

**Calculated:** -

**Data type:** FloatingPoint32

**Can be changed:** T, U

**Scaling:** -

**Dynamic index:** DDS, p0180

**Unit group:** -

**Unit selection:** -

**Function diagram:** -

**Min:**

**Max:**

**Factory setting:**

10 [%]

400 [%]

100 [%]

**Description:**

Sets the search current for the "flying restart" function.

The value is referred to the motor magnetizing current.

**Dependency:**

See also: r0331

**⚠ CAUTION**

An unfavorable parameter value can result in the motor behaving in an uncontrollable fashion.

**NOTICE**

The following applies for a synchronous reluctance motor:

The minimum search current is limited (p1202 >= 50 %).

**Note**

In U/f control mode, the parameter serves as a threshold value for establishing the current at the beginning of the flying restart function. When the threshold value is reached, the actual search current is set as a function of the frequency based on the voltage setpoints.

Reducing the search current can also improve flying restart performance (if the system moment of inertia is not very high, for example).

The following applies for a synchronous reluctance motor:

Adjusting the search current only has an effect if a motor data identification run is then performed (see p1909 bit 22).

It is possible that a value exceeding 100% cannot be reached if the motor rated power is significantly less than that of the power unit.

If the motor rated power is significantly higher than that of the power unit, then the search current should be increased for the higher speed range.



<b>p1203[0...n]</b>	<b>Flying restart search rate factor / FlyRst v_Srch Fact</b>		
	<b>Access level:</b> 3	<b>Calculated:</b> -	<b>Data type:</b> FloatingPoint32
	<b>Can be changed:</b> T, U	<b>Scaling:</b> -	<b>Dynamic index:</b> DDS, p0180
	<b>Unit group:</b> -	<b>Unit selection:</b> -	<b>Function diagram:</b> -
	<b>Min:</b> 10 [%]	<b>Max:</b> 4000 [%]	<b>Factory setting:</b> 100 [%]
<b>Description:</b>	Sets the factor for the search speed for flying restart. The value influences the rate at which the output frequency is changed during a flying restart . A higher value results in a longer search time.		
<b>Recommendation:</b>	For sensorless vector control and motor cables longer than 200 m, set the factor p1203 >= 300 %.		
	<p><b>⚠ CAUTION</b></p> <p>An unfavorable parameter value can result in the motor behaving in an uncontrollable fashion. For vector control, a value that is too low or too high can cause flying restart to become unstable.</p>		
	<p><b>Note</b></p> <p>The parameter factory setting is selected so that standard induction motors that are rotating can be found and restarted as quickly as possible (fast flying restart).</p> <p>With this pre-setting, if the motor is not found (e.g. for motors that are accelerated as a result of active loads or with U/f control and low speeds), we recommend that the search rate is reduced (by increasing p1203).</p> <p>For the flying restart of a reluctance motor, the minimum search velocity is limited (p1203 &gt;= 50 %).</p>		
<b>p1206[0...9]</b>	<b>Automatic restart faults not active / AR fault not act</b>		
	<b>Access level:</b> 3	<b>Calculated:</b> -	<b>Data type:</b> Unsigned16
	<b>Can be changed:</b> T, U	<b>Scaling:</b> -	<b>Dynamic index:</b> -
	<b>Unit group:</b> -	<b>Unit selection:</b> -	<b>Function diagram:</b> -
	<b>Min:</b> 0	<b>Max:</b> 65535	<b>Factory setting:</b> 0
<b>Description:</b>	Sets faults for which automatic restart should not be effective.		
<b>Dependency:</b>	The setting is only effective for p1210 = 6, 16, 26. See also: p1210		
<b>p1210</b>	<b>Automatic restart mode / AR mode</b>		
	<b>Access level:</b> 2	<b>Calculated:</b> -	<b>Data type:</b> Integer16
	<b>Can be changed:</b> T, U	<b>Scaling:</b> -	<b>Dynamic index:</b> -
	<b>Unit group:</b> -	<b>Unit selection:</b> -	<b>Function diagram:</b> -
	<b>Min:</b> 0	<b>Max:</b> 26	<b>Factory setting:</b> 0
<b>Description:</b>	Sets the automatic restart mode (AR). The parameters must be saved in the non-volatile memory p0971 = 1 in order that the setting becomes effective.		
<b>Value:</b>	0: Inhibit automatic restart 1: Acknowledge all faults without restarting 4: Restart after line supply failure w/o additional start attempts 6: Restart after fault with additional start attempts 14: Restart after line supply failure following man. acknowledgment 16: Restart after fault following manual acknowledgment 26: Acknowledging all faults and reclosing for an ON command		
<b>Recommendation:</b>	For brief line supply failures, the motor shaft may still be rotating when restarting. The "flying restart" function (p1200) might need to be activated to restart while the motor shaft is still rotating.		

7.3 Parameter list

**Dependency:** The automatic restart requires an active ON command (e.g., via a digital input). If, for p1210 > 1, there is no active ON command, then the automatic restart is interrupted.  
 When using an Operator Panel in the LOCAL mode, then there is no automatic start.  
 For p1210 = 14, 16, a manual acknowledgment is required for an automatic restart.  
 See also: p0840, p0857, p1267  
 See also: F30003

**⚠ DANGER**  
 If the automatic restart is activated (p1210 > 1) if there is an ON command (refer to p0840), the drive is switched on as soon as any fault messages that are present can be acknowledged. This also occurs after the line supply returns or the Control Unit boots if the DC link voltage is present again. This automatic switching-on operation can only be interrupted by withdrawing the ON command.

**NOTICE**  
 A change is only accepted and made in the state "initialization" (r1214.0) and "wait for alarm" (r1214.1). When faults are present, therefore, the parameter cannot be changed.  
 For p1210 > 1, the motor is automatically started.

**Note**

For p1210 = 1:  
 Faults that are present are automatically acknowledged. If new faults occur after a successful fault acknowledgment, then these are also automatically acknowledged again. p1211 has no influence on the number of acknowledgment attempts.  
 For p1210 = 4:  
 An automatic restart is only performed if fault F30003 has occurred on the power unit. If additional faults are present, then these faults are also acknowledged and when successful, starting continues.  
 For p1210 = 6:  
 An automatic restart is carried out if any fault has occurred.  
 For p1210 = 14:  
 as for p1210 = 4. However, active faults must be manually acknowledged.  
 For p1210 = 16:  
 as for p1210 = 6. However, active faults must be manually acknowledged.  
 For p1210 = 26:  
 as for p1210 = 6. For this mode, the switch-on command can be entered with a delay. The restart is interrupted with either OFF2 or OFF3. Alarm A07321 is only displayed if the cause of the fault has been removed and the drive is restarted by setting the switch-on command.

**p1211**

**Automatic restart start attempts / AR start attempts**

<b>Access level:</b> 3	<b>Calculated:</b> -	<b>Data type:</b> Unsigned16
<b>Can be changed:</b> T, U	<b>Scaling:</b> -	<b>Dynamic index:</b> -
<b>Unit group:</b> -	<b>Unit selection:</b> -	<b>Function diagram:</b> -
<b>Min:</b> 0	<b>Max:</b> 10	<b>Factory setting:</b> 3

**Description:** Sets the start attempts of the automatic restart function for p1210 = 4, 6, 14, 16, 26.

**Dependency:** A change is only accepted and made in the state "initialization" (r1214.0) and "wait for alarm" (r1214.1).  
 See also: p1210  
 See also: F07320

**NOTICE**  
 After fault F07320 occurs, the switch-on command must be withdrawn and all of the faults acknowledged so that the automatic restart function is re-activated.  
 After a complete power failure (blackout) the start counter always starts with the counter value that applied before the power failure, and decrements this start attempt by 1. If a further attempt to acknowledge is started by the automatic restart function prior to power failure, e.g. when the CU remains active on power failure longer than the time p1212 / 2, the fault counter will already have been decremented once. In this case, the start counter is thus decreased by the value 2.

**Note**

A start attempt starts immediately when a fault occurs. The start attempt is considered to be completed if the motor was magnetized ( $r0056.4 = 1$ ) and an additional delay time of 1 s has expired.

As long as a fault is present, an acknowledge command is generated in the time intervals of  $p1212 / 2$ . When successfully acknowledged, the start counter is decremented. If, after this, a fault re-occurs before a restart has been completed, then acknowledgment starts again from the beginning.

Fault F07320 is output if, after several faults occur, the number of parameterized start attempts has been reached. After a successful start attempt, i.e. a fault/error has no longer occurred up to the end of the magnetizing phase, the start counter is again reset to the parameter value after 1 s. If a fault re-occurs - the parameterized number of start attempts is again available.

At least one start attempt is always carried out.

After a line supply failure, acknowledgment is immediate and when the line supply returns, the system is switched on. If, between successfully acknowledging the line fault and the line supply returning, another fault occurs, then its acknowledgment also causes the start counter to be decremented.

For  $p1210 = 26$ :

The start counter is decremented if after a successful fault acknowledgment, the on command is present.

**p1212****Automatic restart delay time start attempts / AR t\_wait start**

**Access level:** 3

**Calculated:** -

**Data type:** FloatingPoint32

**Can be changed:** T, U

**Scaling:** -

**Dynamic index:** -

**Unit group:** -

**Unit selection:** -

**Function diagram:** -

**Min:**

**Max:**

**Factory setting:**

0.1 [s]

1000.0 [s]

1.0 [s]

**Description:** Sets the delay time up to restart.

**Dependency:** This parameter setting is active for  $p1210 = 4, 6, 26$ .

For  $p1210 = 1$ , the following applies:

Faults are only automatically acknowledged in half of the waiting time, no restart.

See also:  $p1210$

**NOTICE**

A change is only accepted and made in the state "initialization" ( $r1214.0$ ) and "wait for alarm" ( $r1214.1$ ).

**Note**

The faults are automatically acknowledged after half of the delay time has expired and the full delay time.

If the cause of a fault is not removed in the first half of the delay time, then it is no longer possible to acknowledge in the delay time.

**p1213[0...1]****Automatic restart monitoring time / AR t\_monit**

**Access level:** 3

**Calculated:** -

**Data type:** FloatingPoint32

**Can be changed:** T, U

**Scaling:** -

**Dynamic index:** -

**Unit group:** -

**Unit selection:** -

**Function diagram:** -

**Min:**

**Max:**

**Factory setting:**

0.0 [s]

10000.0 [s]

[0] 60.0 [s]

[1] 0.0 [s]

**Description:** Sets the monitoring time of the automatic restart (AR).

**Index:** [0] = Restart

[1] = Reset start counter

**Dependency:** See also:  $p1210$

**NOTICE**

A change is only accepted and made in the state "initialization" ( $r1214.0$ ) and "wait for alarm" ( $r1214.1$ ).

After fault F07320 occurs, the switch-on command must be withdrawn and all of the faults acknowledged so that the automatic restart function is re-activated.

7.3 Parameter list

**Note**

For index 0:

The monitoring time starts when the faults are detected. If the automatic acknowledgments are not successful, the monitoring time runs again. If, after the monitoring time has expired, the drive has still not successfully started again (flying restart and magnetizing of the motor must have been completed: r0056.4 = 1), then fault F07320 is output.

The monitoring is deactivated with p1213 = 0. If p1213 is set lower than the sum of p1212, the magnetizing time p0346 and the additional delay time due to the flying restart, then fault F07320 is generated at each restart. If, for p1210 = 1, the time in p1213 is set lower than in p1212, then fault F07320 is also generated at each restart.

The monitoring time must be extended if the faults that occur cannot be immediately and successfully acknowledged (e.g. for faults that are permanently present).

In the case of p1210 = 14, 16, the faults which are present must be acknowledged manually within the time in p1213[0]. Otherwise, fault F07320 is generated after the set time.

For index 1:

The start counter (refer to r1214) is only set back to the starting value p1211 if, after successful restart, the time in p1213[1] has expired. The delay time is not effective for fault acknowledgment without automatic restart (p1210 = 1). After a power failure (blackout) the delay time only starts after the line supply returns and the Control Unit boots. The start counter is set to p1211, if F07320 occurred, the switch-on command is withdrawn and the fault is acknowledged. The start counter is immediately updated if the starting value p1211 or the mode p1210 is changed.

For p1210 = 26, the fault must have been successfully acknowledged and the switch-on command issued within the time in p1213[0]. Otherwise, fault F07320 is generated after the set time.

<b>p1226[0...n]</b>	<b>Threshold for zero speed detection / n_standst n_thresh</b>		
	<b>Access level:</b> 2	<b>Calculated:</b> -	<b>Data type:</b> FloatingPoint32
	<b>Can be changed:</b> T, U	<b>Scaling:</b> -	<b>Dynamic index:</b> DDS, p0180
	<b>Unit group:</b> 3_1	<b>Unit selection:</b> p0505	<b>Function diagram:</b> 8022
	<b>Min:</b> 0.00 [rpm]	<b>Max:</b> 210000.00 [rpm]	<b>Factory setting:</b> 20.00 [rpm]

**Description:** Sets the speed threshold for the standstill identification.  
Acts on the actual value and setpoint monitoring.  
When braking with OFF1 or OFF3, when the threshold is undershot, standstill is identified.

**Dependency:** See also: p1227

**⚠ CAUTION**  
The following applies for encoderless speed control:  
If p1226 is set to values under approx. 1 % of the rated motor speed, then the model switchover limits of the vector control must be increased in order to guarantee reliable shutdown (see p1755, p1750.7).

**NOTICE**  
For reasons relating to the compatibility to earlier firmware versions, a parameter value of zero in indices 1 to 31 is overwritten with the parameter value in index 0 when the Control Unit boots.

**Note**

Standstill is identified in the following cases:

- the speed actual value falls below the speed threshold in p1226 and the time started after this in p1228 has expired.
- the speed setpoint falls below the speed threshold in p1226 and the time started after this in p1227 has expired.

The actual value sensing is subject to measuring noise. For this reason, standstill cannot be detected if the speed threshold is too low.

<b>p1227</b>	<b>Zero speed detection monitoring time / n_standst t_monit</b>		
	<b>Access level:</b> 3	<b>Calculated:</b> -	<b>Data type:</b> FloatingPoint32
	<b>Can be changed:</b> T, U	<b>Scaling:</b> -	<b>Dynamic index:</b> -
	<b>Unit group:</b> -	<b>Unit selection:</b> -	<b>Function diagram:</b> -
	<b>Min:</b> 0.000 [s]	<b>Max:</b> 300.000 [s]	<b>Factory setting:</b> 300.000 [s]

**Description:** Sets the monitoring time for the standstill identification.  
When braking with OFF1 or OFF3, standstill is identified after this time has expired, after the setpoint speed has fallen below p1226 (also refer to p1145).

**Dependency:** The parameter is pre-assigned depending on the size of the power unit.  
See also: p1226

**NOTICE**

For p1145 > 0.0 (RFG tracking) the setpoint is not equal to zero dependent on the selected value. This can therefore cause the monitoring time in p1227 to be exceeded. In this case, for a driven motor, the pulses are not suppressed.

**Note**

Standstill is identified in the following cases:

- the speed actual value falls below the speed threshold in p1226 and the time started after this in p1228 has expired.
- the speed setpoint falls below the speed threshold in p1226 and the time started after this in p1227 has expired.

For p1227 = 300.000 s the following applies:

Monitoring is deactivated.

For p1227 = 0.000 s, the following applies:

With OFF1 or OFF3 and a ramp-down time = 0, the pulses are immediately suppressed and the motor "coasts" down.

Once the Control Unit has been booted up for the first time or if the factory settings have been defined accordingly, the parameter is defined in accordance with the power unit.

---

**p1228**      **Pulse suppression delay time / Pulse suppr t\_del**

<b>Access level:</b> 3	<b>Calculated:</b> -	<b>Data type:</b> FloatingPoint32
<b>Can be changed:</b> T, U	<b>Scaling:</b> -	<b>Dynamic index:</b> -
<b>Unit group:</b> -	<b>Unit selection:</b> -	<b>Function diagram:</b> 8022
<b>Min:</b> 0.000 [s]	<b>Max:</b> 299.000 [s]	<b>Factory setting:</b> 0.010 [s]

**Description:** Sets the delay time for pulse suppression.  
After OFF1 or OFF3, the pulses are canceled, if at least one of the following conditions is fulfilled:

- the speed actual value falls below the threshold in p1226 and the time started after this in p1228 has expired.
- the speed setpoint falls below the threshold in p1226 and the time started after this in p1227 has expired.

**Dependency:** See also: p1226, p1227

---

**p1230[0...n]**      **BI: DC braking activation / DC brake act**

CUG120X_PN (DC braking)	<b>Access level:</b> 2	<b>Calculated:</b> -	<b>Data type:</b> Unsigned32 / Binary
	<b>Can be changed:</b> T, U	<b>Scaling:</b> -	<b>Dynamic index:</b> CDS, p0170
	<b>Unit group:</b> -	<b>Unit selection:</b> -	<b>Function diagram:</b> 7017
	<b>Min:</b> -	<b>Max:</b> -	<b>Factory setting:</b> 0

**Description:** Sets the signal source to activate DC braking.

**Dependency:** See also: p1231, p1232, p1233, p1234, r1239

**Note**

1 signal: DC braking activated.

0 signal: DC braking deactivated.

---

**p1231[0...n]**      **DC braking configuration / DCBRK config**

CUG120X_PN (DC braking)	<b>Access level:</b> 2	<b>Calculated:</b> -	<b>Data type:</b> Integer16
	<b>Can be changed:</b> T, U	<b>Scaling:</b> -	<b>Dynamic index:</b> MDS, p0130
	<b>Unit group:</b> -	<b>Unit selection:</b> -	<b>Function diagram:</b> 7014, 7016, 7017
	<b>Min:</b> 0	<b>Max:</b> 14	<b>Factory setting:</b> 0

7.3 Parameter list

**Description:** Setting to activate DC braking.  
**Value:** 0: No function  
 4: DC braking  
 5: DC braking for OFF1/OFF3  
 14: DC braking below starting speed  
**Dependency:** See also: p0300, p1232, p1233, p1234, r1239

**Note**

DCBRK: DC Braking

For p1231 = 4:

The function is activated as soon as the activation criterion is fulfilled.

- the function can be superseded by an OFF2 response.

Activation criterion (one of the following criteria is fulfilled):

- binector input p1230 = 1 signal (DC braking activation, depending on the operating mode).

- the drive is not in the state "S4: Operation" or in "S5x".

- the internal pulse enable is missing (r0046.19 = 0).

DC braking can only be withdrawn (p1231 = 0) if it is not being used as a fault response in p2101.

In order that DC braking is active as fault response, the corresponding fault number must be entered in p2100 and fault response p2101 set = 6.

For p1231 = 5:

DC braking is activated if the OFF1 or OFF3 command is present. Binector input p1230 is ineffective. If the drive speed still lies above the speed threshold p1234, then initially, the drive is ramped-down to this threshold, demagnetized (see p0347) and is then switched into DC braking for the time set in p1233. After this, the drive is switched-off. If, at OFF1, the drive speed is below p1234, then it is immediately demagnetized and switched into DC braking. The system switches back to normal operation if the OFF1 command is withdrawn prematurely (the system waits for demagnetization). Flying restart must be activated if the motor is still rotating.

DC braking by means of fault response continues to be possible.

For p1231 = 14:

In addition to the function for p1231 = 5, binector input p1230 is evaluated.

DC braking is only automatically activated when the speed threshold p1234 is fallen below if binector input p1230 = 1 signal. This is also the case, if no OFF command is present.

After demagnetization and after the time in p1233 has expired, the drive changes back into normal operation or is switched-off (for OFF1/OFF3).

If a 0 signal is applied to binector input p1230, for OFF1 and OFF3 no DC braking is executed.

---

**p1232[0...n]**      **DC braking current / DCBRK I\_brake**

CUG120X\_PN (DC      **Access level:** 2      **Calculated:** CALC\_MOD\_ALL      **Data type:** FloatingPoint32  
 braking)      **Can be changed:** T, U      **Scaling:** -      **Dynamic index:** MDS, p0130  
                          **Unit group:** -      **Unit selection:** -      **Function diagram:** 7017  
                          **Min:**      **Max:**      **Factory setting:**  
                          0.00 [Arms]      10000.00 [Arms]      0.00 [Arms]

**Description:** Sets the braking current for DC braking.  
**Dependency:** See also: p1230, p1231, p1233, p1234, r1239, p1345, p1346

**Note**

A change to the braking current becomes effective the next time that DC braking is switched on.

The value for p1232 is specified as an rms value in the 3-phase system. The magnitude of the braking current is the same as that of an identical output current at frequency zero (see r0067, r0068, p0640). The braking current is internally limited to r0067.

For the current controller, the settings of parameters p1345 and p1346 (I\_max limiting controller) are used.

<b>p1233[0...n]</b> CUG120X_PN (DC braking)	<b>DC braking time / DCBRK time</b> <b>Access level:</b> 2 <b>Can be changed:</b> T, U <b>Unit group:</b> - <b>Min:</b> 0.0 [s]	<b>Calculated:</b> - <b>Scaling:</b> - <b>Unit selection:</b> - <b>Max:</b> 3600.0 [s]	<b>Data type:</b> FloatingPoint32 <b>Dynamic index:</b> MDS, p0130 <b>Function diagram:</b> 7017 <b>Factory setting:</b> 1.0 [s]																														
<b>Description:</b>	Sets the DC braking time (as fault response).																																
<b>Dependency:</b>	See also: p1230, p1231, p1232, p1234, r1239																																
<b>p1234[0...n]</b> CUG120X_PN (DC braking)	<b>Speed at the start of DC braking / DCBRK n_start</b> <b>Access level:</b> 2 <b>Can be changed:</b> T, U <b>Unit group:</b> - <b>Min:</b> 0.00 [rpm]	<b>Calculated:</b> - <b>Scaling:</b> - <b>Unit selection:</b> - <b>Max:</b> 210000.00 [rpm]	<b>Data type:</b> FloatingPoint32 <b>Dynamic index:</b> MDS, p0130 <b>Function diagram:</b> 7017 <b>Factory setting:</b> 210000.00 [rpm]																														
<b>Description:</b>	Sets the starting speed for DC braking. If the actual speed falls below this threshold, then DC braking is activated.																																
<b>Dependency:</b>	See also: p1230, p1231, p1232, p1233, r1239																																
<b>r1239.8...13</b> CUG120X_PN (DC braking)	<b>CO/BO: DC braking status word / DCBRK ZSW</b> <b>Access level:</b> 2 <b>Can be changed:</b> - <b>Unit group:</b> - <b>Min:</b> -	<b>Calculated:</b> - <b>Scaling:</b> - <b>Unit selection:</b> - <b>Max:</b> -	<b>Data type:</b> Unsigned32 <b>Dynamic index:</b> - <b>Function diagram:</b> - <b>Factory setting:</b> -																														
<b>Description:</b>	Status word of the DC braking.																																
<b>Bit field:</b>	<table border="1"> <thead> <tr> <th>Bit</th> <th>Signal name</th> <th>1 signal</th> <th>0 signal</th> <th>FP</th> </tr> </thead> <tbody> <tr> <td>08</td> <td>DC braking active</td> <td>Yes</td> <td>No</td> <td>7017</td> </tr> <tr> <td>10</td> <td>DC braking ready</td> <td>Yes</td> <td>No</td> <td>7017</td> </tr> <tr> <td>11</td> <td>DC braking selected</td> <td>Yes</td> <td>No</td> <td>-</td> </tr> <tr> <td>12</td> <td>DC braking selection internally inhibited</td> <td>Yes</td> <td>No</td> <td>-</td> </tr> <tr> <td>13</td> <td>DC braking for OFF1/OFF3</td> <td>Yes</td> <td>No</td> <td>-</td> </tr> </tbody> </table>	Bit	Signal name	1 signal	0 signal	FP	08	DC braking active	Yes	No	7017	10	DC braking ready	Yes	No	7017	11	DC braking selected	Yes	No	-	12	DC braking selection internally inhibited	Yes	No	-	13	DC braking for OFF1/OFF3	Yes	No	-		
Bit	Signal name	1 signal	0 signal	FP																													
08	DC braking active	Yes	No	7017																													
10	DC braking ready	Yes	No	7017																													
11	DC braking selected	Yes	No	-																													
12	DC braking selection internally inhibited	Yes	No	-																													
13	DC braking for OFF1/OFF3	Yes	No	-																													
<b>Dependency:</b>	See also: p1231, p1232, p1233, p1234																																
	<b>Note</b> For bit 12, 13: Only effective for p1231 = 14.																																
<b>p1240[0...n]</b>	<b>Vdc controller configuration (vector control) / Vdc ctr config vec</b> <b>Access level:</b> 3 <b>Can be changed:</b> T, U <b>Unit group:</b> - <b>Min:</b> 0	<b>Calculated:</b> - <b>Scaling:</b> - <b>Unit selection:</b> - <b>Max:</b> 3	<b>Data type:</b> Integer16 <b>Dynamic index:</b> DDS, p0180 <b>Function diagram:</b> 6220, 6827 <b>Factory setting:</b> 1																														
<b>Description:</b>	Sets the controller configuration of the DC link voltage (Vdc controller) in the closed-loop control mode. For U/f control: see p1280.																																
<b>Value:</b>	0: Inhibit Vdc ctrl 1: Enable Vdc_max controller 2: Enable Vdc_min controller (kinetic buffering) 3: Enable Vdc_min controller and Vdc_max controller																																

7.3 Parameter list

**Dependency:** See also: p1245  
See also: A07400, A07401, A07402, F07405, F07406

**NOTICE**  
An excessively high value in p1245 can possibly negatively influence the normal operation of the drive.

**Note**  
p1240 = 1, 3:  
When the DC link voltage limit specified for the power unit is reached the following applies:  
- the Vdc\_max controller limits the regenerative energy in order that the DC link voltage is kept below the maximum DC link voltage when braking.  
- the ramp-down times are automatically increased.  
p1240 = 2, 3:  
When the switch-in threshold of the Vdc\_min controller is reached (p1245), the following applies:  
- the Vdc\_min controller limits the energy taken from the DC link in order to keep the DC link voltage above the minimum DC link voltage when accelerating.  
- the motor is braked in order to use its kinetic energy to buffer the DC link.

<b>r1242</b> CUG120X_PN (Vdc_max)	<b>Vdc_max controller switch-in level / Vdc_max on_level</b> <b>Access level:</b> 3 <b>Can be changed:</b> - <b>Unit group:</b> - <b>Min:</b> - [V]	<b>Calculated:</b> - <b>Scaling:</b> p2001 <b>Unit selection:</b> - <b>Max:</b> - [V]	<b>Data type:</b> FloatingPoint32 <b>Dynamic index:</b> - <b>Function diagram:</b> 6220 <b>Factory setting:</b> - [V]
---	--	---	---

**Description:** Displays the switch-in level for the Vdc\_max controller.  
If p1254 = 0 (automatic sensing of the switch-in level = off), then the following applies:  
r1242 = 1.15 \* sqrt(2) \* p0210 (supply voltage)  
PM230: r1242 is limited to Vdc\_max - 50.0 V.  
If p1254 = 1 (automatic sensing of the switch-in level = on), then the following applies:  
r1242 = Vdc\_max - 50.0 V (Vdc\_max: Overvoltage threshold of the power unit)  
r1242 = Vdc\_max - 25.0 V (for 230 V power units)

**NOTICE**  
If the activation level of the Vdc\_max controller is already exceeded in the deactivated state (pulse inhibit) by the DC link voltage, then the controller can be automatically deactivated (see F07401), so that the drive is not accelerated the next time that it is activated.

**Note**  
The Vdc\_max controller is not switched back off until the DC link voltage falls below the threshold 0.95 \* r1242 and the controller output is zero.

<b>p1243[0...n]</b> CUG120X_PN (Vdc_max)	<b>Vdc_max controller dynamic factor / Vdc_max dyn_factor</b> <b>Access level:</b> 3 <b>Can be changed:</b> T, U <b>Unit group:</b> - <b>Min:</b> 1 [%]	<b>Calculated:</b> CALC_MOD_CON <b>Scaling:</b> - <b>Unit selection:</b> - <b>Max:</b> 10000 [%]	<b>Data type:</b> FloatingPoint32 <b>Dynamic index:</b> DDS, p0180 <b>Function diagram:</b> 6220 <b>Factory setting:</b> 100 [%]
--	--	--	--

**Description:** Sets the dynamic factor for the DC link voltage controller (Vdc\_max controller).  
100% means that p1250, p1251, and p1252 (gain, integral time, and rate time) are used corresponding to their basic settings and based on a theoretical controller optimization.  
If subsequent optimization is required, this can be carried out using the dynamic factor. In this case p1250, p1251, p1252 are weighted with the dynamic factor p1243.



<b>p1245[0...n]</b> CUG120X_PN (Vdc_min)	<b>Vdc_min controller switch-in level (kinetic buffering) / Vdc_min on_level</b>		
	<b>Access level:</b> 3	<b>Calculated:</b> -	<b>Data type:</b> FloatingPoint32
	<b>Can be changed:</b> T, U	<b>Scaling:</b> -	<b>Dynamic index:</b> DDS, p0180
	<b>Unit group:</b> -	<b>Unit selection:</b> -	<b>Function diagram:</b> -
	<b>Min:</b> 65 [%]	<b>Max:</b> 150 [%]	<b>Factory setting:</b> 76 [%]
<b>Description:</b>	Sets the switch-in level for the Vdc-min controller (kinetic buffering). The value is obtained as follows: $r1246[V] = p1245[\%] * \sqrt{2} * p0210$		
<b>Dependency:</b>	See also: p0210		
<b>⚠ WARNING</b>			
An excessively high value possibly negatively influences normal drive operation, and can mean that after the line supply returns, the Vdc minimum control can no longer be exited.			
<b>r1246</b> CUG120X_PN (Vdc_min)	<b>Vdc_min controller switch-in level (kinetic buffering) / Vdc_min on_level</b>		
	<b>Access level:</b> 3	<b>Calculated:</b> -	<b>Data type:</b> FloatingPoint32
	<b>Can be changed:</b> -	<b>Scaling:</b> p2001	<b>Dynamic index:</b> -
	<b>Unit group:</b> -	<b>Unit selection:</b> -	<b>Function diagram:</b> 6220
	<b>Min:</b> - [V]	<b>Max:</b> - [V]	<b>Factory setting:</b> - [V]
<b>Description:</b>	Displays the switch-in level for the Vdc_min controller (kinetic buffering).		
<b>Note</b>			
The Vdc_min controller is not switched back off until the DC link voltage rises above the threshold $1.05 * p1246$ and the controller output is zero.			
<b>p1247[0...n]</b> CUG120X_PN (PM330, Vdc_min, Vdc_min)	<b>Vdc_min controller dynamic factor (kinetic buffering) / Vdc_min dyn_factor</b>		
	<b>Access level:</b> 3	<b>Calculated:</b> CALC_MOD_CON	<b>Data type:</b> FloatingPoint32
	<b>Can be changed:</b> T, U	<b>Scaling:</b> -	<b>Dynamic index:</b> DDS, p0180
	<b>Unit group:</b> -	<b>Unit selection:</b> -	<b>Function diagram:</b> 6220
	<b>Min:</b> 1 [%]	<b>Max:</b> 10000 [%]	<b>Factory setting:</b> 300 [%]
<b>Description:</b>	Sets the dynamic factor for the Vdc_min controller (kinetic buffering). 100% means that p1250, p1251, and p1252 (gain, integral time, and rate time) are used corresponding to their basic settings and based on a theoretical controller optimization. If subsequent optimization is required, this can be carried out using the dynamic factor. In this case p1250, p1251, p1252 are weighted with the dynamic factor p1247.		
<b>p1249[0...n]</b> CUG120X_PN (Vdc_max)	<b>Vdc_max controller speed threshold / Vdc_max n_thresh</b>		
	<b>Access level:</b> 3	<b>Calculated:</b> CALC_MOD_ALL	<b>Data type:</b> FloatingPoint32
	<b>Can be changed:</b> T, U	<b>Scaling:</b> -	<b>Dynamic index:</b> DDS, p0180
	<b>Unit group:</b> 3_1	<b>Unit selection:</b> p0505	<b>Function diagram:</b> -
	<b>Min:</b> 0.00 [rpm]	<b>Max:</b> 210000.00 [rpm]	<b>Factory setting:</b> 10.00 [rpm]
<b>Description:</b>	Sets the lower speed threshold for the Vdc_max controller. When this speed threshold is undershot, the Vdc_max control is switched out and the speed is controlled using the ramp-function generator.		
<b>Note</b>			
For fast braking where the ramp-function generator tracking was active, it is possible to prevent the drive rotating in the opposite direction by increasing the speed threshold and setting a final rounding-off time in the ramp-function generator (p1131). This is supported using a dynamic setting of the speed controller.			

<b>p1250[0...n]</b>	<b>Vdc controller proportional gain / Vdc_ctrl Kp</b>	<b>Access level:</b> 3	<b>Calculated:</b> -	<b>Data type:</b> FloatingPoint32
		<b>Can be changed:</b> T, U	<b>Scaling:</b> -	<b>Dynamic index:</b> DDS, p0180
		<b>Unit group:</b> -	<b>Unit selection:</b> -	<b>Function diagram:</b> -
		<b>Min:</b> 0.00	<b>Max:</b> 100.00	<b>Factory setting:</b> 1.00
<b>Description:</b>	Sets the proportional gain for the DC link voltage controller (Vdc_min controller, Vdc_max controller).			
<b>Dependency:</b>	The effective proportional gain is obtained taking into account p1243 (Vdc_max controller dynamic factor) and the DC link capacitance of the power unit.			
<b>p1251[0...n]</b>	<b>Vdc controller integral time / Vdc_ctrl Tn</b>	<b>Access level:</b> 3	<b>Calculated:</b> -	<b>Data type:</b> FloatingPoint32
		<b>Can be changed:</b> T, U	<b>Scaling:</b> -	<b>Dynamic index:</b> DDS, p0180
		<b>Unit group:</b> -	<b>Unit selection:</b> -	<b>Function diagram:</b> 6220
		<b>Min:</b> 0 [ms]	<b>Max:</b> 10000 [ms]	<b>Factory setting:</b> 0 [ms]
<b>Description:</b>	Sets the integral time for the DC link voltage controller (Vdc_min controller, Vdc_max controller).			
<b>Dependency:</b>	The effective integral time is obtained taking into account p1243 (Vdc_max controller dynamic factor).			
	<b>Note</b> p1251 = 0: The integral component is deactivated.			
<b>p1252[0...n]</b>	<b>Vdc controller rate time / Vdc_ctrl t_rate</b>	<b>Access level:</b> 3	<b>Calculated:</b> -	<b>Data type:</b> FloatingPoint32
		<b>Can be changed:</b> T, U	<b>Scaling:</b> -	<b>Dynamic index:</b> DDS, p0180
		<b>Unit group:</b> -	<b>Unit selection:</b> -	<b>Function diagram:</b> 6220
		<b>Min:</b> 0 [ms]	<b>Max:</b> 1000 [ms]	<b>Factory setting:</b> 0 [ms]
<b>Description:</b>	Sets the rate time constant for the DC link voltage controller (Vdc_min controller, Vdc_max controller).			
<b>Dependency:</b>	The effective rate time is obtained taking into account p1243 (Vdc_max controller dynamic factor).			
<b>p1254</b>	<b>Vdc_max controller automatic ON level detection / Vdc_max SenseOnLev</b>	<b>Access level:</b> 3	<b>Calculated:</b> -	<b>Data type:</b> Integer16
		<b>Can be changed:</b> T, U	<b>Scaling:</b> -	<b>Dynamic index:</b> -
		<b>Unit group:</b> -	<b>Unit selection:</b> -	<b>Function diagram:</b> -
		<b>Min:</b> 0	<b>Max:</b> 1	<b>Factory setting:</b> 1
<b>Description:</b>	Activates/deactivates the automatic sensing of the switch-in level for the Vdc_max controller.			
<b>Value:</b>	0: Automatic detection inhibited 1: Automatic detection enabled			
<b>p1255[0...n]</b>	<b>Vdc_min controller time threshold / Vdc_min t_thresh</b>	<b>Access level:</b> 3	<b>Calculated:</b> -	<b>Data type:</b> FloatingPoint32
CUG120X_PN (Vdc_min)		<b>Can be changed:</b> T, U	<b>Scaling:</b> -	<b>Dynamic index:</b> DDS, p0180
		<b>Unit group:</b> -	<b>Unit selection:</b> -	<b>Function diagram:</b> -
		<b>Min:</b> 0.000 [s]	<b>Max:</b> 1800.000 [s]	<b>Factory setting:</b> 0.000 [s]
<b>Description:</b>	Sets the time threshold for the Vdc_min controller (kinetic buffering). If this value is exceeded a fault is output; the required response can be parameterized. Prerequisite: p1256 = 1			

**Dependency:** See also: F07406

**NOTICE**

If a time threshold has been parameterized, the Vdc\_max controller should also be activated (p1240 = 3) so that the drive does not shut down with overvoltage when Vdc\_min control is exited (due to the time violation) and in the event of fault response OFF3. It is also possible to increase the OFF3 ramp-down time p1135.

**p1256[0...n]**

CUG120X\_PN  
(Vdc\_min)

**Vdc\_min controller response (kinetic buffering) / Vdc\_min response**

**Access level:** 3

**Can be changed:** T, U

**Unit group:** -

**Min:**

0

**Calculated:** -

**Scaling:** -

**Unit selection:** -

**Max:**

1

**Data type:** Integer16

**Dynamic index:** DDS, p0180

**Function diagram:** -

**Factory setting:**

0

**Description:**

Sets the response for the Vdc\_min controller (kinetic buffering).

**Value:**

0: Buffer Vdc until undervoltage, n<p1257 -> F07405

1: Buff. Vdc until undervolt., n<p1257 -> F07405, t>p1255 -> F07406

**Dependency:**

See also: F07405, F07406

**p1257[0...n]**

CUG120X\_PN  
(Vdc\_min)

**Vdc\_min controller speed threshold / Vdc\_min n\_thresh**

**Access level:** 3

**Can be changed:** T, U

**Unit group:** 3\_1

**Min:**

0.00 [rpm]

**Calculated:** CALC\_MOD\_ALL

**Scaling:** -

**Unit selection:** p0505

**Max:**

210000.00 [rpm]

**Data type:** FloatingPoint32

**Dynamic index:** DDS, p0180

**Function diagram:** -

**Factory setting:**

50.00 [rpm]

**Description:**

Sets the speed threshold for the Vdc-min controller (kinetic buffering).

If this value is exceeded a fault is output; the required response can be parameterized .

Kinetic buffering is not started below the speed threshold.

**Note**

Exiting the Vdc\_min control before reaching motor standstill prevents the regenerative braking current from increasing significantly at low speeds, and after a pulse inhibit, means that the motor coasts down.

However, the maximum braking torque can be set via the appropriate torque limiting.

**r1258****CO: Vdc controller output / Vdc\_ctrl output**

**Access level:** 3

**Can be changed:** -

**Unit group:** 6\_2

**Min:**

- [Arms]

**Calculated:** -

**Scaling:** p2002

**Unit selection:** p0505

**Max:**

- [Arms]

**Data type:** FloatingPoint32

**Dynamic index:** -

**Function diagram:** 6220

**Factory setting:**

- [Arms]

**Description:**

Displays the actual output of the Vdc controller (DC link voltage controller)

**Note**

The regenerative power limit p1531 is used for vector control to precontrol the Vdc\_max controller. The lower the power limit is set, the lower the correction signals of the controller when the voltage limit is reached.

**p1260****Bypass configuration / Bypass config**

**Access level:** 2

**Can be changed:** T

**Unit group:** -

**Min:**

0

**Calculated:** -

**Scaling:** -

**Unit selection:** -

**Max:**

3

**Data type:** Integer16

**Dynamic index:** -

**Function diagram:** -

**Factory setting:**

0

**Description:**

Sets the configuration for the bypass function.

Parameters

7.3 Parameter list

**Value:** 0: Bypass deactivated  
 3: Bypass without synchronization  
**Dependency:** The "Bypass" function is only available for induction motors.

**Note**

When the converter is switched on, the state of the bridging contactor is evaluated.  
 If the automatic restart is active (p1210 = 4) and both an ON command (r0054.0 = 1) and the bypass signal (p1266 = 1, configuration p1267.0 = 1) are still present during power up, the converter goes into "ready for operation and bypass" state (r0899.0 = 1 and r0046.25 = 1) after power up, and the motor continues to run directly on the line.  
 The "bypass" function can only be switched off again (p1260 = 0) if the bypass is not active or the bypass function has a fault.  
 The "flying restart" function must be activated (p1200).

**r1261.0...11 CO/BO: Bypass control/status word / Bypass STW / ZSW**

**Access level:** 2 **Calculated:** - **Data type:** Unsigned32  
**Can be changed:** - **Scaling:** - **Dynamic index:** -  
**Unit group:** - **Unit selection:** - **Function diagram:** -  
**Min:** - **Max:** - **Factory setting:** -

**Description:** Control and feedback signals of the bypass switch.

Bit	Signal name	1 signal	0 signal	FP
00	Command switch motor - power unit	Close	Open	-
01	Command switch motor - line supply	Close	Open	-
05	Feedback signal switch motor - power unit	Closed	Opened	-
06	Feedback signal switch motor - line supply	Closed	Opened	-
07	Bypass command (from p1266)	Yes	No	-
10	Bypass in process sequence	Yes	No	-
11	Bypass enabled	Yes	No	-

**Dependency:** The "Bypass" function is only available for induction motors.

**Note**

Control bits 0 and 1 should be interconnected to the signal outputs via which the switches in the motor feeder cables should be controlled. These should be selected/dimensioned for switching under load.

**p1262[0...n] Bypass dead time / Bypass t\_dead**

**Access level:** 2 **Calculated:** CALC\_MOD\_REG **Data type:** FloatingPoint32  
**Can be changed:** T, U **Scaling:** - **Dynamic index:** DDS, p0180  
**Unit group:** - **Unit selection:** - **Function diagram:** -  
**Min:** 0.000 [s] **Max:** 20.000 [s] **Factory setting:** 1.000 [s]

**Description:** Sets the dead time for non-synchronized bypass.

**Dependency:** The "Bypass" function is only available for induction motors.

**Note**

This parameter is used to define the changeover time of the contactors. It should not be shorter than the de-magnetizing time of the motor (p0347).  
 The total changeover time for the bypass is based on the total of p1262 plus the OFF time for the relevant switch (p1274[x]).

<b>p1263</b>	<b>Debypass delay time / Debypass t_del</b>		
	<b>Access level:</b> 2	<b>Calculated:</b> -	<b>Data type:</b> FloatingPoint32
<b>Description:</b>	<b>Can be changed:</b> T, U	<b>Scaling:</b> -	<b>Dynamic index:</b> -
	<b>Unit group:</b> -	<b>Unit selection:</b> -	<b>Function diagram:</b> -
<b>Dependency:</b>	<b>Min:</b> 0.000 [s]	<b>Max:</b> 300.000 [s]	<b>Factory setting:</b> 1.000 [s]
	Sets the delay time to switch back to converter operation for a non-synchronized bypass.		
The "Bypass" function is only available for induction motors.			
<b>p1264</b>	<b>Bypass delay time / Bypass t_del</b>		
	<b>Access level:</b> 2	<b>Calculated:</b> -	<b>Data type:</b> FloatingPoint32
<b>Description:</b>	<b>Can be changed:</b> T, U	<b>Scaling:</b> -	<b>Dynamic index:</b> -
	<b>Unit group:</b> -	<b>Unit selection:</b> -	<b>Function diagram:</b> -
<b>Dependency:</b>	<b>Min:</b> 0.000 [s]	<b>Max:</b> 300.000 [s]	<b>Factory setting:</b> 1.000 [s]
	Sets the delay time for switching to line operation for a non-synchronized bypass.		
The "Bypass" function is only available for induction motors.			
<b>p1265</b>	<b>Bypass speed threshold / Bypass n_thresh</b>		
	<b>Access level:</b> 2	<b>Calculated:</b> -	<b>Data type:</b> FloatingPoint32
<b>Description:</b>	<b>Can be changed:</b> T, U	<b>Scaling:</b> p2000	<b>Dynamic index:</b> -
	<b>Unit group:</b> 3_1	<b>Unit selection:</b> p0505	<b>Function diagram:</b> -
<b>Dependency:</b>	<b>Min:</b> 0.00 [rpm]	<b>Max:</b> 210000.00 [rpm]	<b>Factory setting:</b> 1480.00 [rpm]
	Sets the speed threshold to activate the bypass.		
The "Bypass" function is only available for induction motors.			
If the drive setpoint speed is entered via a motorized potentiometer, then the configuration bit p1030.4 should be set in order to ensure the bypass via speed threshold function.			
<b>Note</b>			
When selecting p1260 = 3 and p1267.1 = 1, the bypass is automatically activated when this speed is reached.			
The bypass speed threshold is only effective for positive directions of rotation. If the drive connected to the line supply requires negative speeds, then this can be achieved using p1820 (direction of rotation reversal).			
<b>p1266</b>	<b>BI: Bypass control command / Bypass command</b>		
	<b>Access level:</b> 2	<b>Calculated:</b> -	<b>Data type:</b> Unsigned32 / Binary
<b>Description:</b>	<b>Can be changed:</b> T, U	<b>Scaling:</b> -	<b>Dynamic index:</b> -
	<b>Unit group:</b> -	<b>Unit selection:</b> -	<b>Function diagram:</b> -
<b>Dependency:</b>	<b>Min:</b> -	<b>Max:</b> -	<b>Factory setting:</b> 0
	Sets the signal source for the control command to the bypass.		
The "Bypass" function is only available for induction motors.			
<b>p1267</b>	<b>Bypass changeover source configuration / Chngov_src config</b>		
	<b>Access level:</b> 2	<b>Calculated:</b> -	<b>Data type:</b> Unsigned8
<b>Description:</b>	<b>Can be changed:</b> T, U	<b>Scaling:</b> -	<b>Dynamic index:</b> -
	<b>Unit group:</b> -	<b>Unit selection:</b> -	<b>Function diagram:</b> -
<b>Dependency:</b>	<b>Min:</b> -	<b>Max:</b> -	<b>Factory setting:</b> 0000 bin
	Sets the cause that should initiate the bypass.		

## Parameters

### 7.3 Parameter list

Bit field:	Bit	Signal name	1 signal	0 signal	FP
	00	Bypass via signal (BI: p1266)	Yes	No	-
	01	Bypass via reaching the speed threshold	Yes	No	-

**Dependency:** The "Bypass" function is only available for induction motors.

#### Note

The parameter only has an effect for a non-synchronized bypass.

p1267.0 = 1:

The bypass is initiated by setting a binary signal. When the command is reset, after the debypass delay time (p1263) has expired, operation at the power unit is re-selected.

p1267.1 = 1:

When the speed threshold entered in p1265 is reached, the bypass is switched in. The system only switches back when the speed setpoint again falls below the threshold value.

p1269[0...1]	BI: Bypass switch feedback signal / Bypass FS		
<b>Access level:</b> 3	<b>Calculated:</b> -	<b>Data type:</b> Unsigned32 / Binary	
<b>Can be changed:</b> T, U	<b>Scaling:</b> -	<b>Dynamic index:</b> -	
<b>Unit group:</b> -	<b>Unit selection:</b> -	<b>Function diagram:</b> -	
<b>Min:</b>	<b>Max:</b>	<b>Factory setting:</b>	
-	-	[0] 1261.0	
		[1] 1261.1	

**Description:** Sets the signal source for the feedback signal of the bypass switch.

**Index:** [0] = Switch motor/drive

[1] = Switch motor/line supply

**Dependency:** The "Bypass" function is only available for induction motors.

#### Note

In the case of switches without a feedback signal, interconnect the corresponding control bit as the signal source:

BI: p1269[0] = r1261.0

BI: p1269[1] = r1261.1

Entering p1269 = 0 sets this interconnection automatically for switches without a feedback signal.

p1271[0...n]	Flying restart maximum frequency for the inhibited direction / FlyRes f_max dir		
<b>Access level:</b> 3	<b>Calculated:</b> -	<b>Data type:</b> FloatingPoint32	
<b>Can be changed:</b> T, U	<b>Scaling:</b> -	<b>Dynamic index:</b> DDS, p0180	
<b>Unit group:</b> -	<b>Unit selection:</b> -	<b>Function diagram:</b> -	
<b>Min:</b>	<b>Max:</b>	<b>Factory setting:</b>	
0 [Hz]	650 [Hz]	0 [Hz]	

**Description:** Sets the maximum search frequency for a flying restart in an inhibited setpoint direction (p1110, p1111).

#### Note

The parameter has no effect for an operating mode, which only searches in the setpoint direction (p1200 > 3).

p1271[0...n]	Flying restart maximum frequency for the inhibited direction / FlyRes f_max dir		
<b>Access level:</b> 3	<b>Calculated:</b> -	<b>Data type:</b> FloatingPoint32	
<b>Can be changed:</b> T, U	<b>Scaling:</b> -	<b>Dynamic index:</b> DDS, p0180	
<b>Unit group:</b> -	<b>Unit selection:</b> -	<b>Function diagram:</b> -	
<b>Min:</b>	<b>Max:</b>	<b>Factory setting:</b>	
0 [Hz]	650 [Hz]	5 [Hz]	

**Description:** Sets the maximum search frequency for a flying restart in an inhibited setpoint direction (p1110, p1111).

#### Note

The parameter has no effect for an operating mode, which only searches in the setpoint direction (p1200 > 3).

<b>p1274[0...1]</b>	<b>Bypass switch monitoring time / Switch t_monit</b>			
	<b>Access level:</b> 3	<b>Calculated:</b> -	<b>Data type:</b> FloatingPoint32	
	<b>Can be changed:</b> T, U	<b>Scaling:</b> -	<b>Dynamic index:</b> -	
	<b>Unit group:</b> -	<b>Unit selection:</b> -	<b>Function diagram:</b> -	
	<b>Min:</b> 0 [ms]	<b>Max:</b> 5000 [ms]	<b>Factory setting:</b> 1000 [ms]	
<b>Description:</b>	Sets the monitoring time for the bypass switch.			
<b>Index:</b>	[0] = Switch motor/drive [1] = Switch motor/line supply			
<b>Dependency:</b>	The "Bypass" function is only available for induction motors.			
	<b>Note</b>			
	The monitoring is deactivated with p1274 = 0 ms. The changeover time for the bypass (p1262) is extended by the value in this parameter.			
<b>p1280[0...n]</b>	<b>Vdc controller configuration (U/f) / Vdc_ctr config U/f</b>			
	<b>Access level:</b> 3	<b>Calculated:</b> -	<b>Data type:</b> Integer16	
	<b>Can be changed:</b> T, U	<b>Scaling:</b> -	<b>Dynamic index:</b> DDS, p0180	
	<b>Unit group:</b> -	<b>Unit selection:</b> -	<b>Function diagram:</b> 6300, 6320, 6854	
	<b>Min:</b> 0	<b>Max:</b> 3	<b>Factory setting:</b> 1	
<b>Description:</b>	Sets the configuration of the controller for the DC link voltage (Vdc controller) in the U/f operating mode.			
<b>Value:</b>	0: Inhibit Vdc ctrl 1: Enable Vdc_max controller 2: Enable Vdc_min controller (kinetic buffering) 3: Enable Vdc_min controller and Vdc_max controller			
	<b>Note</b>			
	For high input voltages (p0210), the following settings can improve the degree of ruggedness of the Vdc_max controller:			
	- set the input voltage as low as possible, and in so doing, avoid A07401 (p0210).			
	- set the rounding times (p1130, p1136).			
	- increase the ramp-down times (p1121).			
	- reduce the integral time of the controller (p1291), factor 0.5.			
	- activate the Vdc correction in the current controller (p1810.1 = 1) or reduce the derivative action time of the controller (p1292, factor 0.5).			
	In this case, we generally recommend to use vector control (p1300 = 20) (Vdc controller, see p1240).			
	The following measures are suitable to improve the Vdc_min controller:			
	- Optimize the Vdc_min controller (see p1287).			
	- Activate the Vdc correction in the current controller (p1810.1 = 1).			
<b>p1281[0...n]</b>	<b>Vdc controller configuration / Vdc ctrl config</b>			
	<b>Access level:</b> 3	<b>Calculated:</b> CALC_MOD_ALL	<b>Data type:</b> Unsigned16	
	<b>Can be changed:</b> T, U	<b>Scaling:</b> -	<b>Dynamic index:</b> DDS, p0180	
	<b>Unit group:</b> -	<b>Unit selection:</b> -	<b>Function diagram:</b> -	
	<b>Min:</b> -	<b>Max:</b> -	<b>Factory setting:</b> 0000 bin	
<b>Description:</b>	Sets the configuration for the DC link voltage controller.			
<b>Bit field:</b>	<b>Bit</b>	<b>Signal name</b>	<b>1 signal</b>	<b>0 signal</b>
	00	Vdc min control (U/f) without up ramp	Yes	No
	02	Vdc min shorter wait time when the line returns	Yes	No

**Note**

For bit 00:

Deactivate the ramp-up for Vdc\_min control.

For drives with a mechanical system that can oscillate and high moment of inertia, the speed can be more quickly tracked.

For bit 02:

When the line supply returns, normal operation is resumed earlier, and the system does not wait until the Vdc min controller reaches the setpoint speed.

**r1282**

CUG120X\_PN  
(Vdc\_max)

**Vdc\_max controller switch-in level (U/f) / Vdc\_max on\_level**

**Access level:** 3

**Calculated:** -

**Data type:** FloatingPoint32

**Can be changed:** -

**Scaling:** p2001

**Dynamic index:** -

**Unit group:** -

**Unit selection:** -

**Function diagram:** 6320, 6854

**Min:**

**Max:**

**Factory setting:**

- [V]

- [V]

- [V]

**Description:**

Displays the switch-in level for the Vdc\_max controller.

If p1294 = 0 (automatic sensing of the switch-in level = off), then the following applies:

$r1282 = 1.15 * \sqrt{2} * p0210$  (supply voltage)

If p1294 = 1 (automatic sensing of the switch-in level = on), then the following applies:

$r1282 = Vdc\_max - 50.0\text{ V}$  (Vdc\_max: Overvoltage threshold of the power unit)

$r1282 = Vdc\_max - 25.0\text{ V}$  (for 230 V power units)

**NOTICE**

If the activation level of the Vdc\_max controller is already exceeded in the deactivated state (pulse inhibit) by the DC link voltage, then the controller can be automatically deactivated (see F07401), so that the drive is not accelerated the next time that it is activated.

**Note**

The Vdc\_max controller is not switched back off until the DC link voltage falls below the threshold  $0.95 * r1282$  and the controller output is zero.

**p1283[0...n]**

CUG120X\_PN  
(Vdc\_max)

**Vdc\_max controller dynamic factor (U/f) / Vdc\_max dyn\_factor**

**Access level:** 3

**Calculated:** CALC\_MOD\_CON **Data type:** FloatingPoint32

**Can be changed:** T, U

**Scaling:** -

**Dynamic index:** DDS, p0180

**Unit group:** -

**Unit selection:** -

**Function diagram:** 6320, 6854

**Min:**

**Max:**

**Factory setting:**

1 [%]

10000 [%]

100 [%]

**Description:**

Sets the dynamic factor for the DC link voltage controller (Vdc\_max controller).

100% means that p1290, p1291, and p1292 (gain, integral time, and rate time) are used in accordance with their basic settings and on the basis of a theoretical controller optimization.

If subsequent optimization is required, this can be carried out using the dynamic factor. In this case, p1290, p1291, and p1292 are weighted with the dynamic factor p1283.

**p1284[0...n]****Vdc\_max controller time threshold (U/f) / Vdc\_max t\_thresh**

**Access level:** 3

**Calculated:** CALC\_MOD\_ALL **Data type:** FloatingPoint32

**Can be changed:** T, U

**Scaling:** -

**Dynamic index:** DDS, p0180

**Unit group:** -

**Unit selection:** -

**Function diagram:** -

**Min:**

**Max:**

**Factory setting:**

0.000 [s]

300.000 [s]

4.000 [s]

**Description:**

Sets the monitoring time for the Vdc\_max controller.

If the down ramp of the speed setpoint is held for longer than the time set in p1284, then fault F07404 is output.



<b>p1285[0...n]</b>	<b>Vdc_min controller switch-in level (kinetic buffering) (U/f) / Vdc_min on_level</b>		
	<b>Access level:</b> 3	<b>Calculated:</b> -	<b>Data type:</b> FloatingPoint32
<b>Description:</b>	<b>Can be changed:</b> T, U	<b>Scaling:</b> -	<b>Dynamic index:</b> DDS, p0180
	<b>Unit group:</b> -	<b>Unit selection:</b> -	<b>Function diagram:</b> 6320, 6854
	<b>Min:</b> 65 [%]	<b>Max:</b> 150 [%]	<b>Factory setting:</b> 76 [%]
	Sets the switch-in level for the Vdc-min controller (kinetic buffering). The value is obtained as follows: $r1286[V] = p1285[\%] * \sqrt{2} * p0210$		
	<div style="border: 1px solid black; padding: 2px;"> <p><b>⚠ WARNING</b></p> <p>An excessively high value may adversely affect normal drive operation.</p> </div>		
<b>r1286</b>	<b>Vdc_min controller switch-in level (kinetic buffering) (U/f) / Vdc_min on_level</b>		
	<b>Access level:</b> 3	<b>Calculated:</b> -	<b>Data type:</b> FloatingPoint32
<b>Description:</b>	<b>Can be changed:</b> -	<b>Scaling:</b> p2001	<b>Dynamic index:</b> -
	<b>Unit group:</b> -	<b>Unit selection:</b> -	<b>Function diagram:</b> 6320, 6854
	<b>Min:</b> - [V]	<b>Max:</b> - [V]	<b>Factory setting:</b> - [V]
	Displays the switch-in level for the Vdc_min controller (kinetic buffering).		
	<p><b>Note</b></p> <p>The Vdc_min controller is not switched back off until the DC link voltage rises above the threshold <math>1.05 * r1286</math> and the controller output is zero.</p>		
<b>p1287[0...n]</b>	<b>Vdc_min controller dynamic factor (kinetic buffering) (U/f) / Vdc_min dyn_factor</b>		
	<b>Access level:</b> 3	<b>Calculated:</b> CALC_MOD_CON	<b>Data type:</b> FloatingPoint32
<b>Description:</b>	<b>Can be changed:</b> T, U	<b>Scaling:</b> -	<b>Dynamic index:</b> DDS, p0180
	<b>Unit group:</b> -	<b>Unit selection:</b> -	<b>Function diagram:</b> 6320, 6854
	<b>Min:</b> 1 [%]	<b>Max:</b> 10000 [%]	<b>Factory setting:</b> 100 [%]
	Sets the dynamic factor for the Vdc_min controller (kinetic buffering). 100% means that p1290, p1291, and p1292 (gain, integral time, and rate time) are used corresponding to their basic settings and based on a theoretical controller optimization. If subsequent optimization is required, this can be carried out using the dynamic factor. In this case, p1290, p1291, and p1292 are weighted with the dynamic factor p1287.		
<b>p1290[0...n]</b>	<b>Vdc controller proportional gain (U/f) / Vdc_ctrl Kp</b>		
	<b>Access level:</b> 3	<b>Calculated:</b> CALC_MOD_CON	<b>Data type:</b> FloatingPoint32
<b>Description:</b>	<b>Can be changed:</b> T, U	<b>Scaling:</b> -	<b>Dynamic index:</b> DDS, p0180
	<b>Unit group:</b> -	<b>Unit selection:</b> -	<b>Function diagram:</b> 6320, 6854
	<b>Min:</b> 0.00	<b>Max:</b> 100.00	<b>Factory setting:</b> 1.00
	Sets the proportional gain for the Vdc controller (DC link voltage controller).		
	<p><b>Note</b></p> <p>The gain factor is proportional to the capacitance of the DC link. The parameter is pre-set to a value that is optimally adapted to the capacitance of the power unit.</p>		

<b>p1291[0...n]</b>	<b>Vdc controller integral time (U/f) / Vdc_ctrl Tn</b>		
<b>Access level:</b> 3	<b>Calculated:</b> -	<b>Data type:</b> FloatingPoint32	
<b>Can be changed:</b> T, U	<b>Scaling:</b> -	<b>Dynamic index:</b> DDS, p0180	
<b>Unit group:</b> -	<b>Unit selection:</b> -	<b>Function diagram:</b> 6320, 6854	
<b>Min:</b> 0 [ms]	<b>Max:</b> 10000 [ms]	<b>Factory setting:</b> 40 [ms]	
<b>Description:</b>	Sets the integral time for the Vdc controller (DC link voltage controller).		

<b>p1292[0...n]</b>	<b>Vdc controller rate time (U/f) / Vdc_ctrl t_rate</b>		
<b>Access level:</b> 3	<b>Calculated:</b> CALC_MOD_CON	<b>Data type:</b> FloatingPoint32	
<b>Can be changed:</b> T, U	<b>Scaling:</b> -	<b>Dynamic index:</b> DDS, p0180	
<b>Unit group:</b> -	<b>Unit selection:</b> -	<b>Function diagram:</b> 6320, 6854	
<b>Min:</b> 0 [ms]	<b>Max:</b> 1000 [ms]	<b>Factory setting:</b> 10 [ms]	
<b>Description:</b>	Sets the rate time constant for the Vdc controller (DC link voltage controller).		

<b>p1294</b>	<b>Vdc_max controller automatic detection ON signal level (U/f) / Vdc_max SenseOnLev</b>		
<b>Access level:</b> 3	<b>Calculated:</b> -	<b>Data type:</b> Integer16	
<b>Can be changed:</b> T, U	<b>Scaling:</b> -	<b>Dynamic index:</b> -	
<b>Unit group:</b> -	<b>Unit selection:</b> -	<b>Function diagram:</b> 6320, 6854	
<b>Min:</b> 0	<b>Max:</b> 1	<b>Factory setting:</b> 0	
<b>Description:</b>	Activates/deactivates the automatic sensing of the switch-in level for the Vdc_max controller. When the sensing function is deactivated, the activation threshold r1282 for the Vdc_max controller is determined from the parameterized connection voltage p0210.		
<b>Value:</b>	0: Automatic detection inhibited 1: Automatic detection enabled		

<b>p1295[0...n]</b>	<b>Vdc_min controller time threshold (U/f) / Vdc_min t_thresh</b>		
<b>Access level:</b> 3	<b>Calculated:</b> -	<b>Data type:</b> FloatingPoint32	
<b>Can be changed:</b> T, U	<b>Scaling:</b> -	<b>Dynamic index:</b> DDS, p0180	
<b>Unit group:</b> -	<b>Unit selection:</b> -	<b>Function diagram:</b> -	
<b>Min:</b> 0.000 [s]	<b>Max:</b> 10000.000 [s]	<b>Factory setting:</b> 0.000 [s]	

**Description:** Sets the time threshold for the Vdc\_min controller (kinetic buffering).  
If this value is exceeded a fault is output; the required response can be parameterized.  
Prerequisite: p1296 = 1

**NOTICE**

If a time threshold has been parameterized, the Vdc\_max controller should also be activated (p1280 = 3) so that the drive does not shut down with overvoltage when Vdc\_min control is exited (due to the time violation) and in the event of fault response OFF3. It is also possible to increase the OFF3 ramp-down time p1135.

<b>p1296[0...n]</b>	<b>Vdc_min controller response (kinetic buffering) (U/f) / Vdc_min response</b>		
<b>Access level:</b> 3	<b>Calculated:</b> -	<b>Data type:</b> Integer16	
<b>Can be changed:</b> T, U	<b>Scaling:</b> -	<b>Dynamic index:</b> DDS, p0180	
<b>Unit group:</b> -	<b>Unit selection:</b> -	<b>Function diagram:</b> -	
<b>Min:</b> 0	<b>Max:</b> 1	<b>Factory setting:</b> 0	
<b>Description:</b>	Sets the response for the Vdc_min controller (kinetic buffering).		

<b>Value:</b>	0:	Buffer Vdc until undervoltage, n<p1297 -> F07405
	1:	Buff. Vdc until undervolt., n<p1297 -> F07405, t>p1295 -> F07406

**Note**

For p1296 = 1:

The quick stop ramp entered in p1135 must not be equal to zero, to prevent overcurrent shutdown if F07406 is triggered.

<b>p1297[0...n]</b>	<b>Vdc_min controller speed threshold (U/f) / Vdc_min n_thresh</b>		
	<b>Access level:</b> 3	<b>Calculated:</b> CALC_MOD_ALL	<b>Data type:</b> FloatingPoint32
	<b>Can be changed:</b> T, U	<b>Scaling:</b> -	<b>Dynamic index:</b> DDS, p0180
	<b>Unit group:</b> 3_1	<b>Unit selection:</b> p0505	<b>Function diagram:</b> -
	<b>Min:</b> 0.00 [rpm]	<b>Max:</b> 210000.00 [rpm]	<b>Factory setting:</b> 50.00 [rpm]

**Description:** Sets the speed threshold for the Vdc-min controller (kinetic buffering).  
If this value is exceeded a fault is output; the required response can be parameterized .

**Note**

Exiting the Vdc\_min control before reaching motor standstill prevents the regenerative braking current from increasing significantly at low speeds, and after a pulse inhibit, means that the motor coasts down.

<b>r1298</b>	<b>CO: Vdc controller output (U/f) / Vdc_ctrl output</b>		
	<b>Access level:</b> 3	<b>Calculated:</b> -	<b>Data type:</b> FloatingPoint32
	<b>Can be changed:</b> -	<b>Scaling:</b> p2000	<b>Dynamic index:</b> -
	<b>Unit group:</b> 3_1	<b>Unit selection:</b> p0505	<b>Function diagram:</b> 6320, 6854
	<b>Min:</b> - [rpm]	<b>Max:</b> - [rpm]	<b>Factory setting:</b> - [rpm]

**Description:** Displays the actual output of the Vdc controller (DC link voltage controller)

<b>p1300[0...n]</b>	<b>Open-loop/closed-loop control operating mode / Op/cl-lp ctrl_mode</b>		
	<b>Access level:</b> 2	<b>Calculated:</b> -	<b>Data type:</b> Integer16
	<b>Can be changed:</b> C2(1), T	<b>Scaling:</b> -	<b>Dynamic index:</b> DDS, p0180
	<b>Unit group:</b> -	<b>Unit selection:</b> -	<b>Function diagram:</b> 6300, 6301, 6851, 8012
	<b>Min:</b> 0	<b>Max:</b> 20	<b>Factory setting:</b> 0

**Description:** Sets the open and closed-loop control mode of a drive.

<b>Value:</b>	0:	U/f control with linear characteristic
	1:	U/f control with linear characteristic and FCC
	2:	U/f control with parabolic characteristic
	4:	U/f control with linear characteristic and ECO
	7:	U/f control for a parabolic characteristic and ECO
	20:	Speed control (encoderless)

**Dependency:** For Standard Drive Control (p0096 = 1), settings p1300 = 0, 2 are possible, for Dynamic Drive Control (p0096 = 2) only p1300 = 20 can be set.

Only operation with U/f characteristic is possible if the rated motor speed is not entered (p0311).

See also: p0300, p0311, p0500

**NOTICE**

Active slip compensation is required in the U/f control types with Eco mode (p1300 = 4, 7). The scaling of the slip compensation (p1335) should be set so that the slip is completely compensated (generally 100%).

The Eco mode is only effective in steady-state operation and when the ramp-function generator is not bypassed. In the case of analog setpoints, if required the tolerance for ramp-up and ramp-down should be actively increased for the ramp-function generator using p1148 in order to reliably signal a steady-state condition.

7.3 Parameter list

**Note**

For motors, type p0300 = 6 and 6xx, operation with U/f control is only recommended for diagnostic purposes.

**p1300[0...n]**

CUG120X\_PN  
(PM330)

**Open-loop/closed-loop control operating mode / Op/cl-IP ctrl\_mode**

**Access level:** 2

**Calculated:** -

**Data type:** Integer16

**Can be changed:** C2(1), T

**Scaling:** -

**Dynamic index:** DDS, p0180

**Unit group:** -

**Unit selection:** -

**Function diagram:** 6300, 6301, 6851, 8012

**Min:**

**Max:**

**Factory setting:**

0

20

20

**Description:**

Sets the open and closed-loop control mode of a drive.

**Value:**

- 0: U/f control with linear characteristic
- 1: U/f control with linear characteristic and FCC
- 2: U/f control with parabolic characteristic
- 4: U/f control with linear characteristic and ECO
- 7: U/f control for a parabolic characteristic and ECO
- 20: Speed control (encoderless)

**Dependency:**

For Dynamic Drive Control (p0096 = 2), only p1300 = 20 can be set.  
Only operation with U/f characteristic is possible if the rated motor speed is not entered (p0311).  
See also: p0300, p0311, p0500

**NOTICE**

Active slip compensation is required in the U/f control types with Eco mode (p1300 = 4, 7). The scaling of the slip compensation (p1335) should be set so that the slip is completely compensated (generally 100%).  
The Eco mode is only effective in steady-state operation and when the ramp-function generator is not bypassed. In the case of analog setpoints, if required the tolerance for ramp-up and ramp-down should be actively increased for the ramp-function generator using p1148 in order to reliably signal a steady-state condition.

**Note**

For motors, type p0300 = 14, operation with U/f control is only recommended for diagnostic purposes.

**p1302[0...n]**

**U/f control configuration / U/f config**

**Access level:** 3

**Calculated:** -

**Data type:** Unsigned16

**Can be changed:** T

**Scaling:** -

**Dynamic index:** DDS, p0180

**Unit group:** -

**Unit selection:** -

**Function diagram:** -

**Min:**

**Max:**

**Factory setting:**

-

-

0000 0000 0000 0000 bin

**Description:**

Sets the configuration for the U/f control.

**Bit field:**

Bit	Signal name	1 signal	0 signal	FP
04	Field orientation	Yes	No	-
05	Starting current when accelerating without flux boost	Yes	No	-
07	Inhibit I <sub>q,max</sub> controller I component	Yes	No	-
08	Saturation characteristic for the starting current	Yes	No	-
09	Current boost for fast magnetization	Yes	No	-

**NOTICE**

p1302 bit 5 = 1: (only for field orientation p1302 bit 4 = 1)  
This setting is only selected for very fast acceleration.

**Note**

For bit 04:

Field orientation for the closed-loop control of application class Standard Drive Control (p0096 = 1). The field orientation is activated with the automatic calculation if p0096 is set = 1.

For bit 05 (only effective for p1302.4 = 1):

The starting current when accelerating (p1311) generally results in an increase in the absolute current and flux. With p1302.5 = 1 the current is only increased in the direction of the load. p1302.5 - in conjunction with p1310 and p1311 - are decisive when it comes to defining the quality of the starting response.

For bit 07:

For field orientation (bit04 = 1), an I<sub>q,max</sub> controller supports the current limiting controller (see p1341). Inhibiting the integral component can prevent the drive from stalling under overload conditions.

For bit 08:

Taking into account the saturation characteristic can be activated to improve faster starting operations for high-rating motors.

For bit 09:

For field orientation (bit04 = 1), while the induction motor is being magnetized, the current is automatically increased if the magnetization time p0346 is shortened.

<b>p1310[0...n]</b>	<b>Starting current (voltage boost) permanent / I<sub>start</sub> (U<sub>a</sub>) perm</b>		
	<b>Access level:</b> 2	<b>Calculated:</b> CALC_MOD_ALL	<b>Data type:</b> FloatingPoint32
<b>Description:</b>	<b>Can be changed:</b> T, U	<b>Scaling:</b> -	<b>Dynamic index:</b> DDS, p0180
	<b>Unit group:</b> -	<b>Unit selection:</b> -	<b>Function diagram:</b> 6300, 6301, 6851
<b>Dependency:</b>	<b>Min:</b> 0.0 [%]	<b>Max:</b> 250.0 [%]	<b>Factory setting:</b> 50.0 [%]
	<p>Defines the voltage boost as a [%] referred to the rated motor current (p0305).            The magnitude of the permanent voltage boost is reduced with increasing frequency so that at the rated motor frequency, the rated motor voltage is present.            The magnitude of the boost in Volt at a frequency of zero is defined as follows:  <math display="block">\text{Voltage boost [V]} = 1.732 \times p0305 \text{ (rated motor current [A])} \times r0395 \text{ (stator/primary section resistance [ohm])} \times p1310 \text{ (permanent voltage boost [\%])} / 100 \%</math>           At low output frequencies, there is only a low output voltage in order to maintain the motor flux. However, the output voltage can be too low in order to achieve the following:</p> <ul style="list-style-type: none"> <li>- magnetize the induction motor.</li> <li>- hold the load.</li> <li>- compensate for losses in the system.</li> </ul> <p>This is the reason that the output voltage can be increased using p1310.            The voltage boost can be used for both linear as well as square-law U/f characteristics.            For field orientation (p1302.4 = 1, default setting for Standard Drive Control p0096 = 1), in the vicinity of low output frequencies, a minimum current is impressed with the magnitude of the rated magnetizing current. In this case, for p1310 = 0%, a current setpoint is calculated that corresponds to the no-load case. For p1610 = 100 %, a current setpoint is calculated that corresponds to the rated motor current.</p>		
<p>The starting current (voltage boost) is limited by the current limit p0640.            Only for p1302.4 = 0 (no field orientation):            The accuracy of the starting current depends on the setting of the stator and feeder cable resistance (p0350, p0352).            For vector control, the starting current is realized using p1610.            See also: p1300, p1311, p1312, r1315</p>			

**NOTICE**

The starting current (voltage boost) increases the motor temperature (particularly at zero speed).

7.3 Parameter list

**Note**

The starting current as a result of the voltage boost is only effective for U/f control (p1300).  
 The boost values are combined with one another if the permanent voltage boost (p1310) is used in conjunction with other boost parameters (acceleration boost (p1311), voltage boost for starting (p1312)).  
 However, these parameters are assigned the following priorities: p1310 > p1311, p1312  
 For field orientation (p1302 bit 4 = 1, not PM230, PM250, PM260), then p1310 together with p1311 and p1302.5 are mainly responsible for the quality of the drive response.

**p1311[0...n] Starting current (voltage boost) when accelerating / I\_start accel**

<b>Access level:</b> 2	<b>Calculated:</b> -	<b>Data type:</b> FloatingPoint32
<b>Can be changed:</b> T, U	<b>Scaling:</b> -	<b>Dynamic index:</b> DDS, p0180
<b>Unit group:</b> -	<b>Unit selection:</b> -	<b>Function diagram:</b> 6300, 6301, 6851
<b>Min:</b> 0.0 [%]	<b>Max:</b> 250.0 [%]	<b>Factory setting:</b> 0.0 [%]

**Description:** p1311 only results in a voltage boost when accelerating and generates a supplementary torque to accelerate the load. The voltage boost becomes effective for a positive setpoint increase and disappears as soon as the setpoint has been reached. The build-up and withdrawal of the voltage boost are smoothed.

The magnitude of the boost in Volt at a frequency of zero is defined as follows (not for field orientation):  
 Voltage boost [V] = 1.732 \* p0305 (rated motor current [A]) x r0395 (stator/primary section resistance [ohm]) x p1311 (voltage boost when accelerating [%]) / 100 %

**Dependency:** The current limit p0640 limits the boost.  
 For field orientation (p1302 bit 4 = 1, not PM230, PM250, PM260), p1311 is pre-assigned by the automatic calculation.  
 For vector control, the starting current is realized using p1611.  
 See also: p1300, p1310, p1312, r1315

**NOTICE**

The voltage boost results in a higher motor temperature increase.

**Note**

The voltage boost when accelerating can improve the response to small, positive setpoint changes.  
 Assigning priorities for the voltage boosts: refer to p1310  
 For field orientation (p1302 bit 4 = 1, not PM230, PM250, PM260), then p1311 together with p1310 and p1302.5 are mainly responsible for the quality of the drive response.

**p1312[0...n] Starting current (voltage boost) when starting / I\_start start**

<b>Access level:</b> 2	<b>Calculated:</b> -	<b>Data type:</b> FloatingPoint32
<b>Can be changed:</b> T, U	<b>Scaling:</b> -	<b>Dynamic index:</b> DDS, p0180
<b>Unit group:</b> -	<b>Unit selection:</b> -	<b>Function diagram:</b> 6300, 6301, 6851
<b>Min:</b> 0.0 [%]	<b>Max:</b> 250.0 [%]	<b>Factory setting:</b> 0.0 [%]

**Description:** Setting for an additional voltage boost when powering-up, however, only for the first acceleration phase. The voltage boost becomes effective for a positive setpoint increase and disappears as soon as the setpoint has been reached. The build-up and withdrawal of the voltage boost are smoothed.

**Dependency:** The current limit p0640 limits the boost.  
 See also: p1300, p1310, p1311, r1315

**NOTICE**

The voltage boost results in a higher motor temperature increase.

**Note**

The voltage boost when accelerating can improve the response to small, positive setpoint changes.

Assigning priorities for the voltage boosts: refer to p1310

For field orientation (p1302.4 = 1, not PM230, PM250, PM260), p1312 of the voltage boost is also added in the direction of the load current (non-linear).

<b>r1315</b>	<b>Voltage boost total / U_boost total</b>	<b>Access level:</b> 3	<b>Calculated:</b> -	<b>Data type:</b> FloatingPoint32
		<b>Can be changed:</b> -	<b>Scaling:</b> p2001	<b>Dynamic index:</b> -
		<b>Unit group:</b> -	<b>Unit selection:</b> -	<b>Function diagram:</b> 6301, 6851
		<b>Min:</b>	<b>Max:</b>	<b>Factory setting:</b>
		- [Vrms]	- [Vrms]	- [Vrms]
<b>Description:</b>	Displays the total resulting voltage boost in volt.			
	For field orientation (p1302.4 = 1, not for PM230, PM250, PM260), at low speeds, as a minimum the magnetizing current is set, so that the voltage depends on r0331.			
<b>Dependency:</b>	See also: p1310, p1311, p1312			

<b>p1331[0...n]</b>	<b>Voltage limiting / U_lim</b>	<b>Access level:</b> 3	<b>Calculated:</b> -	<b>Data type:</b> FloatingPoint32
		<b>Can be changed:</b> T, U	<b>Scaling:</b> -	<b>Dynamic index:</b> DDS, p0180
		<b>Unit group:</b> 5_1	<b>Unit selection:</b> p0505	<b>Function diagram:</b> 6300
		<b>Min:</b>	<b>Max:</b>	<b>Factory setting:</b>
		50.00 [Vrms]	2000.00 [Vrms]	1000.00 [Vrms]
<b>Description:</b>	Limiting the voltage setpoint.			
	This means that the output voltage can be reduced with respect to the calculated maximum voltage r0071 and the start of field weakening.			

**Note**

The output voltage is only limited if, as a result of p1331, the maximum output voltage (r0071) is fallen below.

<b>p1333[0...n]</b>	<b>U/f control FCC starting frequency / U/f FCC f_start</b>	<b>Access level:</b> 3	<b>Calculated:</b> CALC_MOD_ALL	<b>Data type:</b> FloatingPoint32
		<b>Can be changed:</b> T, U	<b>Scaling:</b> -	<b>Dynamic index:</b> DDS, p0180
		<b>Unit group:</b> -	<b>Unit selection:</b> -	<b>Function diagram:</b> 6301
		<b>Min:</b>	<b>Max:</b>	<b>Factory setting:</b>
		0.00 [Hz]	3000.00 [Hz]	0.00 [Hz]
<b>Description:</b>	Sets the starting frequency at which FCC (Flux Current Control) is activated.			
<b>Dependency:</b>	The correct operating mode must be set (p1300 = 1, 6).			

**⚠ WARNING**

An excessively low value can result in instability.

**Note**

For p1333 = 0 Hz, the FCC starting frequency is automatically set to 6 % of the rated motor frequency.

<b>p1334[0...n]</b>	<b>U/f control slip compensation starting frequency / Slip comp start</b>	<b>Access level:</b> 3	<b>Calculated:</b> CALC_MOD_ALL	<b>Data type:</b> FloatingPoint32
		<b>Can be changed:</b> T, U	<b>Scaling:</b> -	<b>Dynamic index:</b> DDS, p0180
		<b>Unit group:</b> -	<b>Unit selection:</b> -	<b>Function diagram:</b> 6310, 6853
		<b>Min:</b>	<b>Max:</b>	<b>Factory setting:</b>
		0.00 [Hz]	3000.00 [Hz]	0.00 [Hz]
<b>Description:</b>	Sets the starting frequency of the slip compensation.			

**Note**

For p1334 = 0, the starting frequency of the slip compensation is automatically set to 6 % of the rated motor frequency.

**p1335[0...n]****Slip compensation scaling / Slip comp scal****Access level:** 3**Calculated:** CALC\_MOD\_ALL**Data type:** FloatingPoint32**Can be changed:** T, U**Scaling:** -**Dynamic index:** DDS, p0180**Unit group:** -**Unit selection:** -**Function diagram:** 6300, 6310, 6853**Min:****Max:****Factory setting:**

0.0 [%]

600.0 [%]

0.0 [%]

**Description:**

Sets the setpoint for slip compensation in [%] referred to r0330 (motor rated slip).

p1335 = 0.0 %: Slip compensation deactivated.

p1335 = 100.0 %: The slip is completely compensated.

**Dependency:**

Prerequisite for a precise slip compensation for p1335 = 100 % are the precise motor parameters (p0350 ... p0360). If the parameters are not precisely known, a precise compensation can be achieved by varying p1335.

For U/f control types with Eco optimization (4 and 7), the slip compensation must be activated in order to guarantee correct operation.

For p0096 = 1 (Standard Drive Control), the scaling of the slip compensation is set as default to 100%.

**Note**

The purpose of slip compensation is to maintain a constant motor speed regardless of the applied load. The fact that the motor speed decreases with increasing load is a typical characteristic of induction motors.

For synchronous motors, this effect does not occur and the parameter has no effect in this case.

For the open-loop control modes p1300 = 5 and 6 (textile sector), the slip compensation is internally disabled in order to be able to precisely set the output frequency.

If p1335 is changed during commissioning (p0010 > 0), then it is possible that the old value will no longer be able to be set. The reason for this is that the dynamic limits of p1335 have been changed by a parameter that was set when the drive was commissioned (e.g. p0300).

**p1335[0...n]****Slip compensation scaling / Slip comp scal**CUG120X\_PN  
(PM330)**Access level:** 3**Calculated:** CALC\_MOD\_ALL**Data type:** FloatingPoint32**Can be changed:** T, U**Scaling:** -**Dynamic index:** DDS, p0180**Unit group:** -**Unit selection:** -**Function diagram:** 6300, 6310**Min:****Max:****Factory setting:**

0.0 [%]

600.0 [%]

100.0 [%]

**Description:**

Sets the setpoint for slip compensation in [%] referred to r0330 (motor rated slip).

p1335 = 0.0 %: Slip compensation deactivated.

p1335 = 100.0 %: The slip is completely compensated.

**Dependency:**

Prerequisite for a precise slip compensation for p1335 = 100 % are the precise motor parameters (p0350 ... p0360). If the parameters are not precisely known, a precise compensation can be achieved by varying p1335.

For U/f control types with Eco optimization (4 and 7), the slip compensation must be activated in order to guarantee correct operation.

**Note**

The purpose of slip compensation is to maintain a constant motor speed regardless of the applied load. The fact that the motor speed decreases with increasing load is a typical characteristic of induction motors.

For synchronous motors, this effect does not occur and the parameter has no effect in this case.

For the open-loop control modes p1300 = 5 and 6 (textile sector), the slip compensation is internally disabled in order to be able to precisely set the output frequency.

If p1335 is changed during commissioning (p0010 > 0), then it is possible that the old value will no longer be able to be set. The reason for this is that the dynamic limits of p1335 have been changed by a parameter that was set when the drive was commissioned (e.g. p0300).



<b>p1336[0...n]</b>	<b>Slip compensation limit value / Slip comp lim val</b>		
	<b>Access level:</b> 3	<b>Calculated:</b> -	<b>Data type:</b> FloatingPoint32
<b>Description:</b>	<b>Can be changed:</b> T, U	<b>Scaling:</b> -	<b>Dynamic index:</b> DDS, p0180
	<b>Unit group:</b> -	<b>Unit selection:</b> -	<b>Function diagram:</b> 6310, 6853
<b>Dependency:</b>	<b>Min:</b> 0.00 [%]	<b>Max:</b> 600.00 [%]	<b>Factory setting:</b> 250.00 [%]
	Sets the limit value for slip compensation in [%] referred to r0330 (motor rated slip).		
<b>r1337</b>	<b>CO: Actual slip compensation / Slip comp act val</b>		
	<b>Access level:</b> 3	<b>Calculated:</b> -	<b>Data type:</b> FloatingPoint32
<b>Description:</b>	<b>Can be changed:</b> -	<b>Scaling:</b> PERCENT	<b>Dynamic index:</b> -
	<b>Unit group:</b> -	<b>Unit selection:</b> -	<b>Function diagram:</b> 6310, 6853
<b>Dependency:</b>	<b>Min:</b> - [%]	<b>Max:</b> - [%]	<b>Factory setting:</b> - [%]
	Displays the actual compensated slip [%] referred to r0330 (rated motor slip). p1335 > 0 %: Slip compensation active. See also: p1335		
<b>p1338[0...n]</b>	<b>U/f mode resonance damping gain / Uf Res_damp gain</b>		
	<b>Access level:</b> 3	<b>Calculated:</b> CALC_MOD_CON	<b>Data type:</b> FloatingPoint32
<b>Description:</b>	<b>Can be changed:</b> T, U	<b>Scaling:</b> -	<b>Dynamic index:</b> DDS, p0180
	<b>Unit group:</b> -	<b>Unit selection:</b> -	<b>Function diagram:</b> 6300, 6310, 6853
<b>Dependency:</b>	<b>Min:</b> 0.00	<b>Max:</b> 100.00	<b>Factory setting:</b> 0.00
	Sets the gain for resonance damping for U/f control. See also: p1300, p1349		
<b>Note</b>			
The resonance damping function dampens active current oscillations that frequency occur under no-load conditions. The resonance damping is active in a range from approximately 6 % of the rated motor frequency (p0310). The shutoff frequency is determined by p1349. For the open-loop control modes p1300 = 5 and 6 (textile sectors), the resonance damping is internally disabled in order that the output frequency can be precisely set.			
<b>p1340[0...n]</b>	<b>I_max frequency controller proportional gain / I_max_ctrl Kp</b>		
	<b>Access level:</b> 3	<b>Calculated:</b> CALC_MOD_CON	<b>Data type:</b> FloatingPoint32
<b>Description:</b>	<b>Can be changed:</b> T, U	<b>Scaling:</b> -	<b>Dynamic index:</b> DDS, p0180
	<b>Unit group:</b> -	<b>Unit selection:</b> -	<b>Function diagram:</b> 6300
<b>Dependency:</b>	<b>Min:</b> 0.000	<b>Max:</b> 0.500	<b>Factory setting:</b> 0.000
	Sets the proportional gain of the I_max frequency controller. The I_max controller reduces the drive converter output current if the maximum current (r0067) is exceeded. In the U/f operating modes (p1300) for the I_max control, one controller is used that acts on the output frequency and one controller that acts on the output voltage. The frequency controller reduces the current by decreasing the converter output frequency. The frequency is reduced down to a minimum value (equaling twice rated slip). If the overcurrent condition cannot be successfully resolved using this measure, then the drive converter output voltage is reduced using the I_max voltage controller. Once the overcurrent condition has been resolved, the drive is accelerated along the ramp set in p1120 (ramp-up time).		
In the U/f modes (p1300) for textile applications and for external voltage setpoints, only the I_max voltage controller is used.			

7.3 Parameter list

**NOTICE**  
 When deactivating the I\_max controller, the following must be carefully observed:  
 When the maximum current (r0067) is exceeded, the output current is no longer reduced. The drive is switched off when the overcurrent limits are exceeded.

**Note**  
 The I\_max limiting controller becomes ineffective if the ramp-function generator is deactivated with p1122 = 1.  
 p1341 = 0:  
 I\_max frequency controller deactivated and I\_max voltage controller activated over the complete speed range.

---

**p1341[0...n]**      **I\_max frequency controller integral time / I\_max\_ctrl Tn**

<b>Access level:</b> 3	<b>Calculated:</b> CALC_MOD_CON	<b>Data type:</b> FloatingPoint32
<b>Can be changed:</b> T, U	<b>Scaling:</b> -	<b>Dynamic index:</b> DDS, p0180
<b>Unit group:</b> -	<b>Unit selection:</b> -	<b>Function diagram:</b> 6300, 6850
<b>Min:</b> 0.000 [s]	<b>Max:</b> 50.000 [s]	<b>Factory setting:</b> 0.300 [s]

**Description:** Sets the integral time for the I\_max frequency controller.  
**Dependency:** See also: p1340

---

**Note**  
 When p1341 = 0, the current limiting controller influencing the frequency is deactivated and only the current limiting controller influencing the output voltage remains active (p1345, p1346).  
 In the case of power units with regenerative feedback (PM250, PM260), current limitation control for a regenerative load is always implemented by influencing the frequency. This current limiting function is deactivated with p1340 = p1341 = 0.

---

**r1343**      **CO: I\_max controller frequency output / I\_max\_ctrl f\_outp**

<b>Access level:</b> 3	<b>Calculated:</b> -	<b>Data type:</b> FloatingPoint32
<b>Can be changed:</b> -	<b>Scaling:</b> p2000	<b>Dynamic index:</b> -
<b>Unit group:</b> 3_1	<b>Unit selection:</b> p0505	<b>Function diagram:</b> 6300, 6850
<b>Min:</b> - [rpm]	<b>Max:</b> - [rpm]	<b>Factory setting:</b> - [rpm]

**Description:** Displays the effective frequency limit.  
**Dependency:** See also: p1340

---

**r1344**      **I\_max controller voltage output / I\_max\_ctrl U\_outp**

<b>Access level:</b> 3	<b>Calculated:</b> -	<b>Data type:</b> FloatingPoint32
<b>Can be changed:</b> -	<b>Scaling:</b> p2001	<b>Dynamic index:</b> -
<b>Unit group:</b> 5_1	<b>Unit selection:</b> p0505	<b>Function diagram:</b> 6300
<b>Min:</b> - [Vrms]	<b>Max:</b> - [Vrms]	<b>Factory setting:</b> - [Vrms]

**Description:** Displays the amount by which the converter output voltage is reduced.  
**Dependency:** See also: p1340

---

**p1345[0...n]**      **I\_max voltage controller proportional gain / I\_max\_U\_ctrl Kp**

<b>Access level:</b> 3	<b>Calculated:</b> CALC_MOD_CON	<b>Data type:</b> FloatingPoint32
<b>Can be changed:</b> T, U	<b>Scaling:</b> -	<b>Dynamic index:</b> DDS, p0180
<b>Unit group:</b> -	<b>Unit selection:</b> -	<b>Function diagram:</b> 6300, 7017
<b>Min:</b> 0.000	<b>Max:</b> 100000.000	<b>Factory setting:</b> 0.000

**Description:** Sets the proportional gain for the I\_max voltage controller.

**Dependency:** See also: p1340

**Note**

The controller settings are also used in the current controller of the DC braking (refer to p1232).

**p1346[0...n] I\_max voltage controller integral time / I\_max\_U\_ctrl Tn**

**Access level:** 3

**Calculated:** CALC\_MOD\_CON **Data type:** FloatingPoint32

**Can be changed:** T, U

**Scaling:** -

**Dynamic index:** DDS, p0180

**Unit group:** -

**Unit selection:** -

**Function diagram:** 6300, 7017

**Min:**

**Max:**

**Factory setting:**

0.000 [s]

50.000 [s]

0.030 [s]

**Description:** Sets the integral time for the I\_max voltage controller.

**Dependency:** See also: p1340

**Note**

The controller settings are also used in the current controller of the DC braking (refer to p1232).

For p1346 = 0, the following applies:

The integral time of the I\_max voltage controller is deactivated.

**p1349[0...n] U/f mode resonance damping maximum frequency / Uf res\_damp f\_max**

**Access level:** 3

**Calculated:** CALC\_MOD\_ALL **Data type:** FloatingPoint32

**Can be changed:** T, U

**Scaling:** -

**Dynamic index:** DDS, p0180

**Unit group:** -

**Unit selection:** -

**Function diagram:** 6310

**Min:**

**Max:**

**Factory setting:**

0.00 [Hz]

3000.00 [Hz]

0.00 [Hz]

**Description:** Sets the maximum output frequency for resonance damping for U/f control.  
Resonance damping is inactive above this output frequency.

**Dependency:** See also: p1338

**Note**

For p1349 = 0, the changeover limit is automatically set to 95 % of the rated motor frequency - however, to a max. of 45 Hz.

**p1400[0...n] Speed control configuration / n\_ctrl config**

**Access level:** 3

**Calculated:** -

**Data type:** Unsigned32

**Can be changed:** T, U

**Scaling:** -

**Dynamic index:** DDS, p0180

**Unit group:** -

**Unit selection:** -

**Function diagram:** 6490

**Min:**

**Max:**

**Factory setting:**

-

-

0000 0000 0000 0000 1000  
0000 0010 0001 bin

**Description:** Sets the configuration for the closed-loop speed control.

Bit field:	Bit	Signal name	1 signal	0 signal	FP
	00	Automatic Kp/Tn adaptation active	Yes	No	6040
	05	Kp/Tn adaptation active	Yes	No	6040
	15	Sensorless vector control speed precontrol	Yes	No	6030
	16	I component for limiting	Enable	Hold	6030
	18	Reserved	-	-	-
	19	Anti-windup for integral component	Yes	No	6030
	20	Acceleration model	ON	OFF	6031
	21	Free Tn reduction active	Yes	No	6030
	22	Reserved	-	-	-
	25	Acceleration torque instantaneous in the I/f mode	Yes	No	-

7.3 Parameter list

**Note**

For bit 16:

When the bit is set, the integral component of the speed controller is only held if it reaches the torque limit.

For bit 19, 20:

When this bit is set, speed overshoots when accelerating along the torque limit and for load surges are reduced.

For bit 20:

The acceleration model for the speed setpoint is only active if p1496 is not zero.

For bit 25:

When the bit is set, for high dynamic starting in the I/f mode, the acceleration precontrol torque smoothing only has a short minimum time (4 ms).

**p1400[0...n]**

CUG120X\_PN  
(PM330)

**Speed control configuration / n\_ctrl config**

**Access level:** 3

**Calculated:** -

**Data type:** Unsigned32

**Can be changed:** T, U

**Scaling:** -

**Dynamic index:** DDS, p0180

**Unit group:** -

**Unit selection:** -

**Function diagram:** 6490

**Min:**

**Max:**

**Factory setting:**

-

-

0000 0000 0011 1000 1000  
0000 0010 0001 bin

**Description:**

Sets the configuration for the closed-loop speed control.

**Bit field:**

Bit	Signal name	1 signal	0 signal	FP
00	Automatic Kp/Tn adaptation active	Yes	No	6040
05	Kp/Tn adaptation active	Yes	No	6040
15	Sensorless vector control speed precontrol	Yes	No	6030
16	I component for limiting	Enable	Hold	6030
18	Reserved	-	-	-
19	Anti-windup for integral component	Yes	No	6030
20	Acceleration model	ON	OFF	6031
21	Free Tn reduction active	Yes	No	6030
22	Reserved	-	-	-
25	Acceleration torque instantaneous in the I/f mode	Yes	No	-

**Note**

For bit 16:

When the bit is set, the integral component of the speed controller is only held if it reaches the torque limit.

For bit 19, 20:

When this bit is set, speed overshoots when accelerating along the torque limit and for load surges are reduced.

For bit 20:

The acceleration model for the speed setpoint is only active if p1496 is not zero.

For bit 25:

When the bit is set, for high dynamic starting in the I/f mode, the acceleration precontrol torque smoothing only has a short minimum time (4 ms).

**p1401[0...n]**

**Flux control configuration / Flux ctrl config**

**Access level:** 3

**Calculated:** -

**Data type:** Unsigned16

**Can be changed:** T, U

**Scaling:** -

**Dynamic index:** DDS, p0180

**Unit group:** -

**Unit selection:** -

**Function diagram:** 6491

**Min:**

**Max:**

**Factory setting:**

-

-

0000 0000 0000 1110 bin

**Description:**

Sets the configuration for flux setpoint control

**Bit field:**

Bit	Signal name	1 signal	0 signal	FP
01	Flux setpoint differentiation active	Yes	No	6723

02	Flux build-up control active	Yes	No	6722, 6723
03	Flux characteristic load-dependent	Yes	No	6725
06	Quick magnetizing	Yes	No	6722
09	Dynamic load-dependent flux boost	Yes	No	6790, 6823
10	Flux boost low speed	Yes	No	-
14	Efficiency optimization 2 active	Yes	No	6722, 6837

**Note**

RESM: reluctance synchronous motor (synchronous reluctance motor)

For bit 01:

Initially, the flux is only established with a low rate of rise when magnetizing the induction motor. The flux setpoint p1570 is reached again at the end of the magnetizing time p0346.

The flux differentiation can be switched out if a significant ripple occurs in the field-generating current setpoint (r0075) when entering the field weakening range. However, this is not suitable for fast acceleration operations because then, the flux decays more slowly and the voltage limiting responds.

For bit 02:

The flux build-up control operates during the magnetizing phase p0346 of the induction motor. If it is switched out, a constant current setpoint is injected and the flux is built up corresponding to the rotor time constant.

For bit 03:

Synchronous-reluctance motor:

Activation of the load-dependent optimum flux characteristic.

For bit 06:

Magnetizing is performed with maximum current ( $0.9 \cdot r0067$ ). With active identification of the stator resistance (see p0621) quick magnetizing is internally deactivated and alarm A07416 is displayed. During a flying restart of a rotating motor (see p1200) no quick magnetizing takes place.

For bit 09:

Synchronous reluctance motor (RESM):

Dynamic increase in the flux setpoint when torque is quickly established.

For bit 10:

Synchronous reluctance motor (RESM):

For load-dependent optimum flux characteristic ( $p1401.3 = 1$ ) the flux setpoint is increased at low speeds.

For bit 14:

When the function is activated, the following applies:

- the optimum flux is calculated and the power loss is entered for optimization purposes

- the efficiency optimization (p1580) is not active.

It only makes sense to activate this function if the dynamic response requirements of the speed controller are low.

In order to avoid oscillations, if required, the speed controller parameters should be adapted (increase  $T_n$ , reduce  $K_p$ ).

Further, the smoothing time of the flux setpoint filter (p1582) should be increased.

**r1407.0...23****CO/BO: Status word speed controller / ZSW n\_ctrl**

**Access level:** 3

**Calculated:** -

**Data type:** Unsigned32

**Can be changed:** -

**Scaling:** -

**Dynamic index:** -

**Unit group:** -

**Unit selection:** -

**Function diagram:** 2522

**Min:**

**Max:**

**Factory setting:**

-

-

-

**Description:**

Display and BICO output for the status word of the speed controller.

**Bit field:**

Bit	Signal name	1 signal	0 signal	FP
00	U/f control active	Yes	No	-
01	Encoderless operation active	Yes	No	-
02	Reserved	-	-	-
03	Speed control active	Yes	No	6040
05	Speed controller I component frozen	Yes	No	6040

## 7.3 Parameter list

06	Speed controller I component set	Yes	No	6040
07	Torque limit reached	Yes	No	6060
08	Upper torque limit active	Yes	No	6060
09	Lower torque limit active	Yes	No	6060
10	Reserved	-	-	-
11	Speed setpoint limited	Yes	No	6030
12	Ramp-function generator set	Yes	No	-
13	Encoderless operation due to a fault	Yes	No	-
14	I/f control active	Yes	No	-
15	Torque limit reached (without precontrol)	Yes	No	6060
17	Speed limiting control active	Yes	No	6640
23	Acceleration model activated	Yes	No	-

**r1438****CO: Speed controller speed setpoint / n\_ctrl n\_set****Access level:** 3**Calculated:** -**Data type:** FloatingPoint32**Can be changed:** -**Scaling:** p2000**Dynamic index:** -**Unit group:** 3\_1**Unit selection:** p0505**Function diagram:** 3001, 6020, 6031**Min:****Max:****Factory setting:**

- [rpm]

- [rpm]

- [rpm]

**Description:**

Display and connector output of the speed setpoint after setpoint limiting for the P component of the speed controller. For U/f operation, the value that is displayed is of no relevance.

**Note**

In the standard state (the reference model is deactivated), r1438 = r1439.

**p1452[0...n]****Speed controller speed actual value smoothing time (sensorless) / n\_C n\_act T\_s SL****Access level:** 2**Calculated:** -**Data type:** FloatingPoint32**Can be changed:** T, U**Scaling:** -**Dynamic index:** DDS, p0180**Unit group:** -**Unit selection:** -**Function diagram:** 6020, 6040**Min:****Max:****Factory setting:**

0.00 [ms]

32000.00 [ms]

10.00 [ms]

**Description:**

Sets the smoothing time for the actual speed of the speed controller for encoderless closed-loop speed control.

**Note**

The smoothing must be increased if there is gear backlash. For longer smoothing times, the integral time of the speed controller must also be increased (e.g. using p0340 = 4).

**p1461[0...n]****Speed controller Kp adaptation speed upper scaling / n\_ctr Kp n up scal****Access level:** 3**Calculated:** CALC\_MOD\_CON **Data type:** FloatingPoint32**Can be changed:** T, U**Scaling:** -**Dynamic index:** DDS, p0180**Unit group:** -**Unit selection:** -**Function diagram:** 6050**Min:****Max:****Factory setting:**

0.0 [%]

200000.0 [%]

100.0 [%]

**Description:**

Sets the P gain of the speed controller for the upper adaptation speed range (> p1465).

The entry is made referred to the P gain for the lower adaptation speed range of the speed controller (% referred to p1470).

**Dependency:**

See also: p1464, p1465

**Note**

If the upper transition point p1465 of the speed controller adaptation is set to lower values than the lower transition p1464, then the controller gain below p1465 is adapted with p1461. This means that an adaptation can be implemented for low speeds without having to change the controller parameters.

<b>p1463[0...n]</b>	<b>Speed controller Tn adaptation speed upper scaling / n_ctr Tn n up scal</b>		
	<b>Access level:</b> 3	<b>Calculated:</b> CALC_MOD_CON	<b>Data type:</b> FloatingPoint32
	<b>Can be changed:</b> T, U	<b>Scaling:</b> -	<b>Dynamic index:</b> DDS, p0180
	<b>Unit group:</b> -	<b>Unit selection:</b> -	<b>Function diagram:</b> 6050
	<b>Min:</b> 0.0 [%]	<b>Max:</b> 200000.0 [%]	<b>Factory setting:</b> 100.0 [%]
<b>Description:</b>	Sets the integral time of the speed controller after the adaptation speed range (> p1465). The entry is made referred to the integral time for the lower adaptation speed range of the speed controller (% referred to p1472).		
<b>Dependency:</b>	See also: p1464, p1465		

**Note**

If the upper transition point p1465 of the speed controller adaptation is set to lower values than the lower transition point p1464, then the controller integral time below p1465 is adapted with p1463. This means that an adaptation can be implemented for low speeds without having to change the controller parameters.

<b>p1464[0...n]</b>	<b>Speed controller adaptation speed lower / n_ctrl n lower</b>		
	<b>Access level:</b> 3	<b>Calculated:</b> CALC_MOD_CON	<b>Data type:</b> FloatingPoint32
	<b>Can be changed:</b> T, U	<b>Scaling:</b> -	<b>Dynamic index:</b> DDS, p0180
	<b>Unit group:</b> 3_1	<b>Unit selection:</b> p0505	<b>Function diagram:</b> 6050
	<b>Min:</b> 0.00 [rpm]	<b>Max:</b> 210000.00 [rpm]	<b>Factory setting:</b> 0.00 [rpm]
<b>Description:</b>	Sets the lower adaptation speed of the speed controller. No adaptation is effective below this speed.		
<b>Dependency:</b>	See also: p1461, p1463, p1465		

**Note**

If the upper transition point p1465 of the speed controller adaptation is set to lower values than the lower transition point p1464, then the controller below p1465 is adapted with p1461 or p1463. This means that an adaptation can be implemented for low speeds without having to change the controller parameters.

<b>p1465[0...n]</b>	<b>Speed controller adaptation speed upper / n_ctrl n upper</b>		
	<b>Access level:</b> 3	<b>Calculated:</b> CALC_MOD_CON	<b>Data type:</b> FloatingPoint32
	<b>Can be changed:</b> T, U	<b>Scaling:</b> -	<b>Dynamic index:</b> DDS, p0180
	<b>Unit group:</b> 3_1	<b>Unit selection:</b> p0505	<b>Function diagram:</b> 6050
	<b>Min:</b> 0.00 [rpm]	<b>Max:</b> 210000.00 [rpm]	<b>Factory setting:</b> 210000.00 [rpm]
<b>Description:</b>	Sets the upper adaptation speed of the speed controller. No adaptation is effective above this speed. For the proportional gain, p1470 x p1461 is effective. For the integral time, p1472 x p1463 is effective.		
<b>Dependency:</b>	See also: p1461, p1463, p1464		

**Note**

If the upper transition point p1465 of the speed controller adaptation is set to lower values than the lower transition point p1464, then the controller below p1465 is adapted with p1461 or p1463. This means that an adaptation can be implemented for low speeds without having to change the controller parameters.

<b>p1470[0...n]</b>	<b>Speed controller encoderless operation P-gain / n_ctrl SL Kp</b>		
	<b>Access level:</b> 2	<b>Calculated:</b> CALC_MOD_CON	<b>Data type:</b> FloatingPoint32
<b>Description:</b>	<b>Can be changed:</b> T, U	<b>Scaling:</b> -	<b>Dynamic index:</b> DDS, p0180
	<b>Unit group:</b> -	<b>Unit selection:</b> -	<b>Function diagram:</b> 6040, 6050
<b>Description:</b>	<b>Min:</b> 0.000	<b>Max:</b> 999999.000	<b>Factory setting:</b> 0.300
	<b>Note</b> The product p0341 x p0342 is taken into account when automatically calculating the speed controller (p0340 = 1, 3, 4).		
<b>p1472[0...n]</b>	<b>Speed controller encoderless operation integral time / n_ctrl SL Tn</b>		
	<b>Access level:</b> 2	<b>Calculated:</b> CALC_MOD_CON	<b>Data type:</b> FloatingPoint32
<b>Description:</b>	<b>Can be changed:</b> T, U	<b>Scaling:</b> -	<b>Dynamic index:</b> DDS, p0180
	<b>Unit group:</b> -	<b>Unit selection:</b> -	<b>Function diagram:</b> 6040, 6050
<b>Description:</b>	<b>Min:</b> 0.0 [ms]	<b>Max:</b> 100000.0 [ms]	<b>Factory setting:</b> 20.0 [ms]
	<b>Note</b> The integral component is stopped if the complete controller output or the sum of controller output and torque precontrol reach the torque limit.		
<b>r1482</b>	<b>CO: Speed controller I torque output / n_ctrl I-M_outp</b>		
	<b>Access level:</b> 3	<b>Calculated:</b> -	<b>Data type:</b> FloatingPoint32
<b>Description:</b>	<b>Can be changed:</b> -	<b>Scaling:</b> p2003	<b>Dynamic index:</b> -
	<b>Unit group:</b> 7_1	<b>Unit selection:</b> p0505	<b>Function diagram:</b> 5040, 5042, 5210, 6030, 6040
<b>Description:</b>	<b>Min:</b> - [Nm]	<b>Max:</b> - [Nm]	<b>Factory setting:</b> - [Nm]
	<b>Note</b> Display and connector output for the torque setpoint at the output of the I speed controller.		
<b>r1493</b>	<b>CO: Moment of inertia total, scaled / M_inert tot scal</b>		
	<b>Access level:</b> 3	<b>Calculated:</b> -	<b>Data type:</b> FloatingPoint32
<b>Description:</b>	<b>Can be changed:</b> -	<b>Scaling:</b> -	<b>Dynamic index:</b> -
	<b>Unit group:</b> 25_1	<b>Unit selection:</b> p0100	<b>Function diagram:</b> 6031
<b>Description:</b>	<b>Min:</b> - [kgm <sup>2</sup> ]	<b>Max:</b> - [kgm <sup>2</sup> ]	<b>Factory setting:</b> - [kgm <sup>2</sup> ]
	<b>Note</b> Display and connector output for the parameterized total moment of inertia. The value is calculated as follows: (p0341 * p0342) + p1496		
<b>p1496[0...n]</b>	<b>Acceleration precontrol scaling / a_prectrl scal</b>		
	<b>Access level:</b> 3	<b>Calculated:</b> -	<b>Data type:</b> FloatingPoint32
<b>Description:</b>	<b>Can be changed:</b> T, U	<b>Scaling:</b> -	<b>Dynamic index:</b> DDS, p0180
	<b>Unit group:</b> -	<b>Unit selection:</b> -	<b>Function diagram:</b> 6020, 6031
<b>Description:</b>	<b>Min:</b> 0.0 [%]	<b>Max:</b> 10000.0 [%]	<b>Factory setting:</b> 0.0 [%]
	<b>Note</b> Sets the scaling for the acceleration precontrol of the speed/velocity controller.		
<b>Dependency:</b>	See also: p0341, p0342		



<b>⚠ WARNING</b>
The acceleration precontrol r1518 is kept at the old value if the ramp-function generator tracking (r1199.5) is active or the ramp-function generator output is set (r1199.3). This is used to avoid torque peaks. Depending on the application, it may therefore be necessary to disable the ramp-function generator tracking (p1145 = 0) or the acceleration precontrol (p1496 = 0).
The acceleration precontrol is set to zero, if the Vdc control is active (r0056.14/15).

**Note**

The parameter is set to 100% by the rotating measurement (refer to p1960).

The acceleration precontrol may not be used if the speed setpoint manifests significant ripple (e.g. analog setpoint) and the rounding-off in the speed ramp-function generator is disabled.

We also recommend that the precontrol mode is not used if there is gearbox backlash.

<b>p1496[0...n]</b> CUG120X_PN (PM330)	<b>Acceleration precontrol scaling / a_prectrl scal</b>		
	<b>Access level:</b> 3	<b>Calculated:</b> -	<b>Data type:</b> FloatingPoint32
	<b>Can be changed:</b> T, U	<b>Scaling:</b> -	<b>Dynamic index:</b> DDS, p0180
	<b>Unit group:</b> -	<b>Unit selection:</b> -	<b>Function diagram:</b> 6020, 6031
	<b>Min:</b> 0.0 [%]	<b>Max:</b> 10000.0 [%]	<b>Factory setting:</b> 100.0 [%]
<b>Description:</b>	Sets the scaling for the acceleration precontrol of the speed/velocity controller.		
<b>Dependency:</b>	See also: p0341, p0342		

<b>⚠ WARNING</b>
The acceleration precontrol r1518 is kept at the old value if the ramp-function generator tracking (r1199.5) is active or the ramp-function generator output is set (r1199.3). This is used to avoid torque peaks. Depending on the application, it may therefore be necessary to disable the ramp-function generator tracking (p1145 = 0) or the acceleration precontrol (p1496 = 0).
The acceleration precontrol is set to zero, if the Vdc control is active (r0056.14/15).

**Note**

The parameter is set to 100% by the rotating measurement (refer to p1960).

The acceleration precontrol may not be used if the speed setpoint manifests significant ripple (e.g. analog setpoint) and the rounding-off in the speed ramp-function generator is disabled.

We also recommend that the precontrol mode is not used if there is gearbox backlash.

<b>r1508</b>	<b>CO: Torque setpoint before supplementary torque / M_set bef. M_suppl</b>		
	<b>Access level:</b> 2	<b>Calculated:</b> -	<b>Data type:</b> FloatingPoint32
	<b>Can be changed:</b> -	<b>Scaling:</b> p2003	<b>Dynamic index:</b> -
	<b>Unit group:</b> 7_1	<b>Unit selection:</b> p0505	<b>Function diagram:</b> 6030, 6060, 6722
	<b>Min:</b> - [Nm]	<b>Max:</b> - [Nm]	<b>Factory setting:</b> - [Nm]
<b>Description:</b>	Displays the torque setpoint before entering the supplementary torque. For closed-loop speed control, r1508 corresponds to the speed controller output.		

<b>r1518[0...1]</b>	<b>CO: Accelerating torque / M_accel</b>		
	<b>Access level:</b> 3	<b>Calculated:</b> -	<b>Data type:</b> FloatingPoint32
	<b>Can be changed:</b> -	<b>Scaling:</b> p2003	<b>Dynamic index:</b> -
	<b>Unit group:</b> 7_1	<b>Unit selection:</b> p0505	<b>Function diagram:</b> 6060
	<b>Min:</b> - [Nm]	<b>Max:</b> - [Nm]	<b>Factory setting:</b> - [Nm]
<b>Description:</b>	Displays the accelerating torque for precontrol of the speed controller.		

## Parameters

### 7.3 Parameter list

**Index:** [0] = Unsmoothed  
[1] = Smoothed

**Dependency:** See also: p0341, p0342, p1496

---

**p1520[0...n]**      **CO: Torque limit upper / M\_max upper**

<b>Access level:</b> 2	<b>Calculated:</b> CALC_MOD_LIM_REF	<b>Data type:</b> FloatingPoint32
<b>Can be changed:</b> T, U	<b>Scaling:</b> p2003	<b>Dynamic index:</b> DDS, p0180
<b>Unit group:</b> 7_1	<b>Unit selection:</b> p0505	<b>Function diagram:</b> 6020, 6630
<b>Min:</b> -1000000.00 [Nm]	<b>Max:</b> 20000000.00 [Nm]	<b>Factory setting:</b> 0.00 [Nm]

**Description:** Sets the fixed, upper torque limit.

**Dependency:** See also: p1521, p1522, p1523, r1538, r1539

**⚠ DANGER**

Negative values when setting the upper torque limit (p1520 < 0) can result in the motor accelerating in an uncontrollable fashion.

**NOTICE**

A BICO interconnection to a parameter that belongs to a drive data set always acts on the effective data set.

**Note**

The torque limit is limited to 400% of the rated motor torque. When automatically calculating the motor/closed-loop control parameters (p0340), the torque limit is set to match the current limit (p0640).

---

**p1521[0...n]**      **CO: Torque limit lower / M\_max lower**

<b>Access level:</b> 2	<b>Calculated:</b> CALC_MOD_LIM_REF	<b>Data type:</b> FloatingPoint32
<b>Can be changed:</b> T, U	<b>Scaling:</b> p2003	<b>Dynamic index:</b> DDS, p0180
<b>Unit group:</b> 7_1	<b>Unit selection:</b> p0505	<b>Function diagram:</b> 6020, 6630
<b>Min:</b> -20000000.00 [Nm]	<b>Max:</b> 1000000.00 [Nm]	<b>Factory setting:</b> 0.00 [Nm]

**Description:** Sets the fixed, lower torque limit.

**Dependency:** See also: p1520, p1522, p1523

**⚠ DANGER**

Positive values when setting the lower torque limit (p1521 > 0) can result in the motor accelerating in an uncontrollable fashion.

**NOTICE**

A BICO interconnection to a parameter that belongs to a drive data set always acts on the effective data set.

**Note**

The torque limit is limited to 400% of the rated motor torque. When automatically calculating the motor/closed-loop control parameters (p0340), the torque limit is set to match the current limit (p0640).

---

**p1522[0...n]**      **CI: Torque limit upper / M\_max upper**

<b>Access level:</b> 3	<b>Calculated:</b> -	<b>Data type:</b> Unsigned32 / FloatingPoint32
<b>Can be changed:</b> T	<b>Scaling:</b> p2003	<b>Dynamic index:</b> CDS, p0170
<b>Unit group:</b> -	<b>Unit selection:</b> -	<b>Function diagram:</b> 6630
<b>Min:</b> -	<b>Max:</b> -	<b>Factory setting:</b> 1520[0]

**Description:** Sets the signal source for the upper torque limit.

**Dependency:** See also: p1520, p1521, p1523

**⚠ DANGER**

Negative values resulting from the signal source and scaling can cause the motor to accelerate in an uncontrolled manner.

**p1523[0...n]**

**CI: Torque limit lower / M\_max lower**

**Access level:** 3

**Calculated:** -

**Data type:** Unsigned32 / FloatingPoint32

**Can be changed:** T

**Scaling:** p2003

**Dynamic index:** CDS, p0170

**Unit group:** -

**Unit selection:** -

**Function diagram:** 6020, 6630

**Min:**

**Max:**

**Factory setting:**

-

-

1521[0]

**Description:** Sets the signal source for the lower torque limit.

**Dependency:** See also: p1520, p1521, p1522

**⚠ DANGER**

Positive values resulting from the signal source and scaling can cause the motor to accelerate in an uncontrolled manner.

**p1524[0...n]**

**CO: Torque limit upper/motoring scaling / M\_max up/mot scal**

**Access level:** 3

**Calculated:** -

**Data type:** FloatingPoint32

**Can be changed:** T, U

**Scaling:** PERCENT

**Dynamic index:** DDS, p0180

**Unit group:** -

**Unit selection:** -

**Function diagram:** 5620, 5630

**Min:**

**Max:**

**Factory setting:**

-2000.0 [%]

2000.0 [%]

100.0 [%]

**Description:** Sets the scaling for the upper torque limit or the torque limit when motoring.

**Dependency:** p1400.4 = 0: upper/lower

p1400.4 = 1: motoring / regenerating

**NOTICE**

A BICO interconnection to a parameter that belongs to a drive data set always acts on the effective data set.

**Note**

This parameter can be freely interconnected.

The value has the meaning stated above if it is interconnected from connector input p1528.

**p1525[0...n]**

**CO: Torque limit lower scaling / M\_max lower scal**

**Access level:** 3

**Calculated:** -

**Data type:** FloatingPoint32

**Can be changed:** T, U

**Scaling:** PERCENT

**Dynamic index:** DDS, p0180

**Unit group:** -

**Unit selection:** -

**Function diagram:** 6630

**Min:**

**Max:**

**Factory setting:**

-2000.0 [%]

2000.0 [%]

100.0 [%]

**Description:** Sets the scaling for the lower torque limit.

**NOTICE**

A BICO interconnection to a parameter that belongs to a drive data set always acts on the effective data set.

**Note**

This parameter can be freely interconnected.

The value has the meaning stated above if it is interconnected from connector input p1528.

---

<b>r1526</b>	<b>CO: Torque limit upper without offset / M_max up w/o offs</b>		
	<b>Access level:</b> 3	<b>Calculated:</b> -	<b>Data type:</b> FloatingPoint32
	<b>Can be changed:</b> -	<b>Scaling:</b> p2003	<b>Dynamic index:</b> -
	<b>Unit group:</b> 7_1	<b>Unit selection:</b> p0505	<b>Function diagram:</b> 6060, 6630, 6640
	<b>Min:</b> - [Nm]	<b>Max:</b> - [Nm]	<b>Factory setting:</b> - [Nm]
<b>Description:</b>	Display and connector output for the upper torque limit of all torque limits without offset.		
<b>Dependency:</b>	See also: p1520, p1521, p1522, p1523		

---

<b>r1527</b>	<b>CO: Torque limit lower without offset / M_max low w/o offs</b>		
	<b>Access level:</b> 3	<b>Calculated:</b> -	<b>Data type:</b> FloatingPoint32
	<b>Can be changed:</b> -	<b>Scaling:</b> p2003	<b>Dynamic index:</b> -
	<b>Unit group:</b> 7_1	<b>Unit selection:</b> p0505	<b>Function diagram:</b> 6060, 6630, 6640
	<b>Min:</b> - [Nm]	<b>Max:</b> - [Nm]	<b>Factory setting:</b> - [Nm]
<b>Description:</b>	Display and connector output for the lower torque limit of all torque limits without offset.		
<b>Dependency:</b>	See also: p1520, p1521, p1522, p1523		

---

<b>p1530[0...n]</b>	<b>Power limit motoring / P_max mot</b>		
	<b>Access level:</b> 2	<b>Calculated:</b> CALC_MOD_LIM_REF	<b>Data type:</b> FloatingPoint32
	<b>Can be changed:</b> T, U	<b>Scaling:</b> -	<b>Dynamic index:</b> DDS, p0180
	<b>Unit group:</b> 14_5	<b>Unit selection:</b> p0505	<b>Function diagram:</b> 6640
	<b>Min:</b> 0.00 [kW]	<b>Max:</b> 100000.00 [kW]	<b>Factory setting:</b> 0.00 [kW]
<b>Description:</b>	Sets the power limit when motoring.		
<b>Dependency:</b>	See also: p0500, p1531		

---

**Note**

The power limit is limited to 300% of the rated motor power.

---

<b>p1531[0...n]</b>	<b>Power limit regenerative / P_max gen</b>		
	<b>Access level:</b> 2	<b>Calculated:</b> CALC_MOD_LIM_REF	<b>Data type:</b> FloatingPoint32
	<b>Can be changed:</b> T, U	<b>Scaling:</b> -	<b>Dynamic index:</b> DDS, p0180
	<b>Unit group:</b> 14_5	<b>Unit selection:</b> p0505	<b>Function diagram:</b> 6640
	<b>Min:</b> -100000.00 [kW]	<b>Max:</b> -0.01 [kW]	<b>Factory setting:</b> -0.01 [kW]
<b>Description:</b>	Sets the regenerative power limit.		
<b>Dependency:</b>	See also: r0206, p0500, p1530		

---

**Note**

The power limit is limited to 300% of the rated motor power.

For power units without energy recovery capability, the regenerative power limit is preset to 30 % of the power r0206[0].

For power units with energy recovery, the parameter is limited to the negative value of r0206[2].

---

---

<b>r1533</b>	<b>Current limit torque-generating total / Iq_max total</b>		
	<b>Access level:</b> 3	<b>Calculated:</b> -	<b>Data type:</b> FloatingPoint32
	<b>Can be changed:</b> -	<b>Scaling:</b> p2002	<b>Dynamic index:</b> -
	<b>Unit group:</b> 6_2	<b>Unit selection:</b> p0505	<b>Function diagram:</b> 6640
	<b>Min:</b> - [Arms]	<b>Max:</b> - [Arms]	<b>Factory setting:</b> - [Arms]
<b>Description:</b>	Displays the maximum torque/force generating current as a result if all current limits.		

---

<b>r1538</b>	<b>CO: Upper effective torque limit / M_max upper eff</b>		
	<b>Access level:</b> 2	<b>Calculated:</b> -	<b>Data type:</b> FloatingPoint32
	<b>Can be changed:</b> -	<b>Scaling:</b> p2003	<b>Dynamic index:</b> -
	<b>Unit group:</b> 7_1	<b>Unit selection:</b> p0505	<b>Function diagram:</b> 6020, 6640
	<b>Min:</b> - [Nm]	<b>Max:</b> - [Nm]	<b>Factory setting:</b> - [Nm]
<b>Description:</b>	Display and connector output for the actual effective upper torque limit.		

---

**Note**

The effective upper torque limit is reduced with respect to the selected upper torque limit p1520, if the current limit p0640 is reduced or the rated magnetizing current of the induction motor p0320 is increased. This may be the case for rotating measurements (see p1960).  
The torque limit p1520 can be re-calculated using p0340 = 1, 3 or 5.

---

<b>r1539</b>	<b>CO: Lower effective torque limit / M_max lower eff</b>		
	<b>Access level:</b> 2	<b>Calculated:</b> -	<b>Data type:</b> FloatingPoint32
	<b>Can be changed:</b> -	<b>Scaling:</b> p2003	<b>Dynamic index:</b> -
	<b>Unit group:</b> 7_1	<b>Unit selection:</b> p0505	<b>Function diagram:</b> 6020, 6640
	<b>Min:</b> - [Nm]	<b>Max:</b> - [Nm]	<b>Factory setting:</b> - [Nm]
<b>Description:</b>	Display and connector output for the actual effective lower torque limit.		

---

**Note**

The effective lower torque limit is reduced with respect to the selected lower torque limit p1521, if the current limit p0640 is reduced or the rated magnetizing current of the induction motor p0320 is increased. This may be the case for rotating measurements (see p1960).  
The torque limit p1520 can be re-calculated using p0340 = 1, 3 or 5.

---

<b>r1547[0...1]</b>	<b>CO: Torque limit for speed controller output / M_max outp n_ctrl</b>		
	<b>Access level:</b> 3	<b>Calculated:</b> -	<b>Data type:</b> FloatingPoint32
	<b>Can be changed:</b> -	<b>Scaling:</b> p2003	<b>Dynamic index:</b> -
	<b>Unit group:</b> 7_1	<b>Unit selection:</b> p0505	<b>Function diagram:</b> 6060
	<b>Min:</b> - [Nm]	<b>Max:</b> - [Nm]	<b>Factory setting:</b> - [Nm]
<b>Description:</b>	Displays the torque limit to limit the speed controller output.		
<b>Index:</b>	[0] = Upper limit [1] = Lower limit		

## 7.3 Parameter list

<b>p1552[0...n]</b>	<b>CI: Torque limit upper scaling without offset / M_max up w/o offs</b>		
	<b>Access level:</b> 3	<b>Calculated:</b> -	<b>Data type:</b> Unsigned32 / FloatingPoint32
	<b>Can be changed:</b> T	<b>Scaling:</b> PERCENT	<b>Dynamic index:</b> CDS, p0170
	<b>Unit group:</b> -	<b>Unit selection:</b> -	<b>Function diagram:</b> 6060
	<b>Min:</b> -	<b>Max:</b> -	<b>Factory setting:</b> 1
<b>Description:</b>	Sets the signal source for the scaling of the upper torque limiting to limit the speed controller output without taking into account the current and power limits.		
<b>p1554[0...n]</b>	<b>CI: Torque limit lower scaling without offset / M_max low w/o offs</b>		
	<b>Access level:</b> 3	<b>Calculated:</b> -	<b>Data type:</b> Unsigned32 / FloatingPoint32
	<b>Can be changed:</b> T	<b>Scaling:</b> PERCENT	<b>Dynamic index:</b> CDS, p0170
	<b>Unit group:</b> -	<b>Unit selection:</b> -	<b>Function diagram:</b> 6060
	<b>Min:</b> -	<b>Max:</b> -	<b>Factory setting:</b> 1
<b>Description:</b>	Sets the signal source for the scaling of the lower torque limiting to limit the speed controller output without taking into account the current and power limits.		
<b>r1566[0...n]</b>	<b>Flux reduction torque factor transition value / Flux red M trans</b>		
	<b>Access level:</b> 3	<b>Calculated:</b> -	<b>Data type:</b> FloatingPoint32
	<b>Can be changed:</b> -	<b>Scaling:</b> PERCENT	<b>Dynamic index:</b> DDS, p0180
	<b>Unit group:</b> -	<b>Unit selection:</b> -	<b>Function diagram:</b> 6790
	<b>Min:</b> - [%]	<b>Max:</b> - [%]	<b>Factory setting:</b> - [%]
<b>Description:</b>	The following applies for a synchronous reluctance motor: Displays the transition value for the start of the evaluation of the optimum flux characteristic. The value is referred to the rated motor torque.		
	<b>Note</b> The transition value corresponds with the lower limit of the flux setpoint (p1581). For a lower absolute torque setpoint, the flux setpoint remains at the lower limit (p1581).		
<b>p1570[0...n]</b>	<b>CO: Flux setpoint / Flex setp</b>		
	<b>Access level:</b> 3	<b>Calculated:</b> CALC_MOD_LIM_REF	<b>Data type:</b> FloatingPoint32
	<b>Can be changed:</b> T, U	<b>Scaling:</b> PERCENT	<b>Dynamic index:</b> DDS, p0180
	<b>Unit group:</b> -	<b>Unit selection:</b> -	<b>Function diagram:</b> 6722
	<b>Min:</b> 50.0 [%]	<b>Max:</b> 200.0 [%]	<b>Factory setting:</b> 100.0 [%]
<b>Description:</b>	Sets the flux setpoint referred to rated motor flux. The following applies for a synchronous reluctance motor: Scaling the flux setpoint.		
	<b>NOTICE</b> A BICO interconnection to a parameter that belongs to a drive data set always acts on the effective data set.		

**Note**

For p1570 > 100%, the flux setpoint increases as a function of the load from 100% (no-load operation) to the setting in p1570 (above rated motor torque), if p1580 > 0% has been set.

The following applies for a synchronous reluctance motor:

The scaling allows the flux setpoint to be adapted when operating with load-dependent optimum flux characteristic or with constant flux setpoint.

**p1570[0...n]**

CUG120X\_PN  
(PM330)

**CO: Flux setpoint / Flex setp**

**Access level:** 3

**Calculated:**  
CALC\_MOD\_LIM\_REF

**Data type:** FloatingPoint32

**Can be changed:** T, U

**Scaling:** PERCENT

**Dynamic index:** DDS, p0180

**Unit group:** -

**Unit selection:** -

**Function diagram:** 6722

**Min:**

**Max:**

**Factory setting:**

50.0 [%]

200.0 [%]

103.0 [%]

**Description:**

Sets the flux setpoint referred to rated motor flux.

The following applies for a synchronous reluctance motor:

Scaling the flux setpoint.

**Dependency:**

See also: p0500

**NOTICE**

A BICO interconnection to a parameter that belongs to a drive data set always acts on the effective data set.

**Note**

For p1570 > 100%, the flux setpoint increases as a function of the load from 100% (no-load operation) to the setting in p1570 (above rated motor torque), if p1580 > 0% has been set.

The following applies for a synchronous reluctance motor:

The scaling allows the flux setpoint to be adapted when operating with load-dependent optimum flux characteristic or with constant flux setpoint.

**p1574[0...n]****Voltage reserve dynamic / U\_reserve dyn**

**Access level:** 3

**Calculated:**  
CALC\_MOD\_LIM\_REF

**Data type:** FloatingPoint32

**Can be changed:** T, U

**Scaling:** -

**Dynamic index:** DDS, p0180

**Unit group:** 5\_1

**Unit selection:** p0505

**Function diagram:** 6723, 6724

**Min:**

**Max:**

**Factory setting:**

0.0 [Vrms]

150.0 [Vrms]

10.0 [Vrms]

**Description:**

Sets a dynamic voltage reserve.

**Dependency:**

See also: p0500

**Note**

In the field weakening range, it must be expected that the control dynamic performance is somewhat restricted due to the limited possibilities of controlling/adjusting the voltage. This can be improved by increasing the voltage reserve. Increasing the reserve reduces the steady-state maximum output voltage (r0071).

**p1574[0...n]**

CUG120X\_PN  
(PM330)

**Voltage reserve dynamic / U\_reserve dyn**

**Access level:** 3

**Calculated:**  
CALC\_MOD\_LIM\_REF

**Data type:** FloatingPoint32

**Can be changed:** T, U

**Scaling:** -

**Dynamic index:** DDS, p0180

**Unit group:** 5\_1

**Unit selection:** p0505

**Function diagram:** 6723, 6724

**Min:**

**Max:**

**Factory setting:**

0.0 [Vrms]

150.0 [Vrms]

2.0 [Vrms]

**Description:**

Sets a dynamic voltage reserve.

**Dependency:**

See also: p0500

**Note**

In the field weakening range, it must be expected that the control dynamic performance is somewhat restricted due to the limited possibilities of controlling/adjusting the voltage. This can be improved by increasing the voltage reserve. Increasing the reserve reduces the steady-state maximum output voltage (r0071).

**p1578[0...n]****Flux reduction flux decrease time constant / Flux red dec T**

<b>Access level:</b> 3	<b>Calculated:</b> CALC_MOD_CON	<b>Data type:</b> FloatingPoint32
<b>Can be changed:</b> T, U	<b>Scaling:</b> -	<b>Dynamic index:</b> DDS, p0180
<b>Unit group:</b> -	<b>Unit selection:</b> -	<b>Function diagram:</b> 6791
<b>Min:</b> 20 [ms]	<b>Max:</b> 5000 [ms]	<b>Factory setting:</b> 200 [ms]

**Description:**

The following applies for a synchronous reluctance motor:  
Sets the time constant for reducing the flux setpoint for a load-dependent optimum flux characteristic.

**Dependency:**

See also: p1579

**Note**

To avoid remagnetization processes for load-dependent flux characteristics and for fast load changes, the time constant to reduce the flux setpoint must be set to an appropriately high value.  
As a consequence, it is preset with a multiple of the time constant used for the flux build up.

**p1579[0...n]****Flux reduction flux build-up time constant / Flux red incr T**

<b>Access level:</b> 3	<b>Calculated:</b> CALC_MOD_CON	<b>Data type:</b> FloatingPoint32
<b>Can be changed:</b> T, U	<b>Scaling:</b> -	<b>Dynamic index:</b> DDS, p0180
<b>Unit group:</b> -	<b>Unit selection:</b> -	<b>Function diagram:</b> 6791
<b>Min:</b> 0 [ms]	<b>Max:</b> 5000 [ms]	<b>Factory setting:</b> 4 [ms]

**Description:**

The following applies for a synchronous reluctance motor:  
Sets the time constant for establishing the flux setpoint for a load-dependent optimum flux characteristic.

**Dependency:**

See also: p1578

**Note**

To quickly establish the flux for torque changes, an appropriately short time constant for the flux build-up must be selected.  
It is preset with the inverse value of the rated motor frequency (p0310).

**p1580[0...n]****Efficiency optimization / Efficiency opt.**

<b>Access level:</b> 3	<b>Calculated:</b> CALC_MOD_LIM_REF	<b>Data type:</b> FloatingPoint32
<b>Can be changed:</b> T, U	<b>Scaling:</b> -	<b>Dynamic index:</b> DDS, p0180
<b>Unit group:</b> -	<b>Unit selection:</b> -	<b>Function diagram:</b> 6722
<b>Min:</b> 0 [%]	<b>Max:</b> 100 [%]	<b>Factory setting:</b> 0 [%]

**Description:**

Sets the efficiency optimization.  
When optimizing the efficiency, the flux setpoint of the closed-loop control is adapted as a function of the load.  
For p1580 = 100 %, under no-load operating conditions, the flux setpoint is reduced to 50 % of the rated motor flux.

**Note**

It only makes sense to activate this function if the dynamic response requirements of the speed controller are low.  
In order to avoid oscillations, if required, the speed controller parameters should be adapted (increase Tn, reduce Kp).  
Further, the smoothing time of the flux setpoint filter (p1582) should be increased.



<b>p1580[0...n]</b> CUG120X_PN (PM330)	<b>Efficiency optimization / Efficiency opt.</b> <b>Access level:</b> 3 <b>Can be changed:</b> T, U <b>Unit group:</b> - <b>Min:</b> 0 [%]	<b>Calculated:</b> CALC_MOD_LIM_REF <b>Scaling:</b> - <b>Unit selection:</b> - <b>Max:</b> 100 [%]	<b>Data type:</b> FloatingPoint32 <b>Dynamic index:</b> DDS, p0180 <b>Function diagram:</b> 6722 <b>Factory setting:</b> 100 [%]
<b>Description:</b>	Sets the efficiency optimization. When optimizing the efficiency, the flux setpoint of the closed-loop control is adapted as a function of the load. For p1580 = 100 %, under no-load operating conditions, the flux setpoint is reduced to 50 % of the rated motor flux.		
<b>Dependency:</b>	See also: p0500		
	<b>Note</b> It only makes sense to activate this function if the dynamic response requirements of the speed controller are low. In order to avoid oscillations, if required, the speed controller parameters should be adapted (increase Tn, reduce Kp). Further, the smoothing time of the flux setpoint filter (p1582) should be increased.		
<b>p1581[0...n]</b>	<b>Flux reduction factor / Flux red factor</b> <b>Access level:</b> 3 <b>Can be changed:</b> T, U <b>Unit group:</b> - <b>Min:</b> 0 [%]	<b>Calculated:</b> - <b>Scaling:</b> - <b>Unit selection:</b> - <b>Max:</b> 100 [%]	<b>Data type:</b> FloatingPoint32 <b>Dynamic index:</b> DDS, p0180 <b>Function diagram:</b> - <b>Factory setting:</b> 100 [%]
<b>Description:</b>	The following applies for a synchronous reluctance motor: Sets the lower limit of the flux setpoint to evaluate the optimum flux characteristic. The value is referred to the rated motor flux (p0357 * r0331).		
<b>p1582[0...n]</b>	<b>Flux setpoint smoothing time / Flux setp T_smth</b> <b>Access level:</b> 3 <b>Can be changed:</b> T, U <b>Unit group:</b> - <b>Min:</b> 4 [ms]	<b>Calculated:</b> CALC_MOD_REG <b>Scaling:</b> - <b>Unit selection:</b> - <b>Max:</b> 5000 [ms]	<b>Data type:</b> FloatingPoint32 <b>Dynamic index:</b> DDS, p0180 <b>Function diagram:</b> 6722, 6724 <b>Factory setting:</b> 15 [ms]
<b>Description:</b>	Sets the smoothing time for the flux setpoint.		
<b>p1596[0...n]</b>	<b>Field weakening controller integral-action time / Field_ctrl Tn</b> <b>Access level:</b> 3 <b>Can be changed:</b> T, U <b>Unit group:</b> - <b>Min:</b> 10 [ms]	<b>Calculated:</b> CALC_MOD_CON <b>Scaling:</b> - <b>Unit selection:</b> - <b>Max:</b> 10000 [ms]	<b>Data type:</b> FloatingPoint32 <b>Dynamic index:</b> DDS, p0180 <b>Function diagram:</b> 6723, 6724 <b>Factory setting:</b> 300 [ms]
<b>Description:</b>	Sets the integral-action time of the field-weakening controller.		
<b>r1598</b>	<b>CO: Total flux setpoint / Flux setp total</b> <b>Access level:</b> 3 <b>Can be changed:</b> - <b>Unit group:</b> - <b>Min:</b> - [%]	<b>Calculated:</b> - <b>Scaling:</b> PERCENT <b>Unit selection:</b> - <b>Max:</b> - [%]	<b>Data type:</b> FloatingPoint32 <b>Dynamic index:</b> - <b>Function diagram:</b> 6714, 6723, 6724, 6725, 6726 <b>Factory setting:</b> - [%]

7.3 Parameter list

**Description:** Displays the effective flux setpoint.  
The value is referred to the rated motor flux.

**p1601[0...n]**      **Current injection ramp time / I\_inject t\_ramp**

<b>Access level:</b> 3	<b>Calculated:</b> CALC_MOD_REG	<b>Data type:</b> FloatingPoint32
<b>Can be changed:</b> T, U	<b>Scaling:</b> -	<b>Dynamic index:</b> DDS, p0180
<b>Unit group:</b> -	<b>Unit selection:</b> -	<b>Function diagram:</b> 6790
<b>Min:</b> 1 [ms]	<b>Max:</b> 10000 [ms]	<b>Factory setting:</b> 20 [ms]

**Description:** Synchronous-reluctance motor:  
Sets the ramp-up time of the current setpoint (p1610, p1611) when switching over from closed-loop controlled to open-loop controlled operation.

**p1610[0...n]**      **Torque setpoint static (sensorless) / M\_set static**

<b>Access level:</b> 2	<b>Calculated:</b> -	<b>Data type:</b> FloatingPoint32
<b>Can be changed:</b> T, U	<b>Scaling:</b> -	<b>Dynamic index:</b> DDS, p0180
<b>Unit group:</b> -	<b>Unit selection:</b> -	<b>Function diagram:</b> 6700, 6721, 6722, 6726
<b>Min:</b> -200.0 [%]	<b>Max:</b> 200.0 [%]	<b>Factory setting:</b> 50.0 [%]

**Description:** Sets the static torque setpoint for sensorless vector control in the low speed range.  
This parameter is entered as a percentage referred to the rated motor torque (r0333).  
For sensorless vector control, when the motor model is shut down, an absolute current is impressed. p1610 represents the maximum load that occurs at a constant setpoint speed.

**NOTICE**  
p1610 should always be set to at least 10 % higher than the maximum steady-state load that can occur.

**Note**  
For p1610 = 0%, a current setpoint is calculated that corresponds to the no-load case (ASM: rated magnetizing current, RESM: no-load magnetizing current).  
For p1610 = 100 %, a current setpoint is calculated that corresponds to the rated motor torque.  
Negative values are converted into positive setpoints in the case of induction and permanent-magnet synchronous motors as well as closed-loop controlled reluctance motors.

**p1611[0...n]**      **Additional acceleration torque (sensorless) / M\_suppl\_accel**

<b>Access level:</b> 2	<b>Calculated:</b> CALC_MOD_ALL	<b>Data type:</b> FloatingPoint32
<b>Can be changed:</b> T, U	<b>Scaling:</b> -	<b>Dynamic index:</b> DDS, p0180
<b>Unit group:</b> -	<b>Unit selection:</b> -	<b>Function diagram:</b> 6700, 6721, 6722, 6726
<b>Min:</b> 0.0 [%]	<b>Max:</b> 200.0 [%]	<b>Factory setting:</b> 30.0 [%]

**Description:** Enters the dynamic torque setpoint for the low-speed range for sensorless vector control.  
This parameter is entered as a percentage referred to the rated motor torque (r0333).

**Note**  
When accelerating and braking p1611 is added to p1610 and the resulting total torque is converted into an appropriate current setpoint and controlled.  
For pure accelerating torques, it is always favorable to use the torque precontrol of the speed controller (p1496).

<b>p1616[0...n]</b>	<b>Current setpoint smoothing time / I_set T_smooth</b>		
	<b>Access level:</b> 3	<b>Calculated:</b> CALC_MOD_REG	<b>Data type:</b> FloatingPoint32
<b>Description:</b>	<b>Can be changed:</b> T, U	<b>Scaling:</b> -	<b>Dynamic index:</b> DDS, p0180
	<b>Unit group:</b> -	<b>Unit selection:</b> -	<b>Function diagram:</b> 6721, 6722
	<b>Min:</b> 4 [ms]	<b>Max:</b> 10000 [ms]	<b>Factory setting:</b> 40 [ms]
	Sets the smoothing time for the current setpoint.		
	The current setpoint is generated from p1610 and p1611.		
<b>Note</b>			
This parameter is only effective in the range where current is injected for sensorless vector control.			
<b>p1740[0...n]</b>	<b>Gain resonance damping for encoderless closed-loop control / Gain res_damp</b>		
	<b>Access level:</b> 3	<b>Calculated:</b> CALC_MOD_CON	<b>Data type:</b> FloatingPoint32
<b>Description:</b>	<b>Can be changed:</b> T, U	<b>Scaling:</b> -	<b>Dynamic index:</b> DDS, p0180
	<b>Unit group:</b> -	<b>Unit selection:</b> -	<b>Function diagram:</b> -
	<b>Min:</b> 0.000	<b>Max:</b> 10.000	<b>Factory setting:</b> 0.025
	Defines the gain of the controller for resonance damping for operation with sensorless vector control in the range that current is injected.		
<b>p1745[0...n]</b>	<b>Motor model error threshold stall detection / MotMod ThreshStall</b>		
	<b>Access level:</b> 3	<b>Calculated:</b> CALC_MOD_REG	<b>Data type:</b> FloatingPoint32
<b>Description:</b>	<b>Can be changed:</b> T, U	<b>Scaling:</b> -	<b>Dynamic index:</b> DDS, p0180
	<b>Unit group:</b> -	<b>Unit selection:</b> -	<b>Function diagram:</b> -
	<b>Min:</b> 0.0 [%]	<b>Max:</b> 1000.0 [%]	<b>Factory setting:</b> 5.0 [%]
	Sets the fault threshold in order to detect a motor that has stalled.		
	If the error signal (r1746) exceeds the parameterized error threshold, then status signal r1408.12 is set to 1.		
<b>Dependency:</b>	If a stalled drive is detected (r1408.12 = 1), fault F07902 is output after the delay time set in p2178.		
	See also: p2178		
<b>Note</b>			
Monitoring is only effective in the low-speed range (below p1755 * (100% - p1756)).			
<b>r1746</b>	<b>Motor model error signal stall detection / MotMod sig stall</b>		
	<b>Access level:</b> 3	<b>Calculated:</b> -	<b>Data type:</b> FloatingPoint32
<b>Description:</b>	<b>Can be changed:</b> -	<b>Scaling:</b> -	<b>Dynamic index:</b> -
	<b>Unit group:</b> -	<b>Unit selection:</b> -	<b>Function diagram:</b> -
	<b>Min:</b> - [%]	<b>Max:</b> - [%]	<b>Factory setting:</b> - [%]
	Signal to initiate stall detection		
<b>Note</b>			
The signal is not calculated while magnetizing and only in the low speed range (below p1755 * (100 % - p1756)).			

7.3 Parameter list

<b>p1750[0...n]</b>	<b>Motor model configuration / MotMod config</b>		
	<b>Access level:</b> 3	<b>Calculated:</b> CALC_MOD_LIM_REF	<b>Data type:</b> Unsigned16
	<b>Can be changed:</b> T, U	<b>Scaling:</b> -	<b>Dynamic index:</b> DDS, p0180
	<b>Unit group:</b> -	<b>Unit selection:</b> -	<b>Function diagram:</b> -
	<b>Min:</b> -	<b>Max:</b> -	<b>Factory setting:</b> 0000 0000 0000 0000 bin

**Description:** Sets the configuration for the motor model.  
 Bit 0 = 1: Forces open-loop speed-controlled starting (ASM).  
 Bit 1 = 1: Forces the system to pass through frequency zero, open-loop-controlled (ASM).  
 Bit 2 = 1: Drive remains in full closed-loop control mode, even at zero frequency (ASM).  
 Bit 3 = 1: Motor model evaluates the saturation characteristic (ASM).  
 Bit 6 = 1: If the motor is blocked, sensorless vector control remains speed-controlled (ASM).  
 Bit 7 = 1: Use rugged switchover limits to switchover the model (open-loop/closed-loop controlled) for regenerative operation (ASM).  
 Bit 8 = 1: Open-loop speed controlled operation independent of the speed setpoint (except for OFF3) (ASM).

<b>Bit field:</b>	<b>Bit</b>	<b>Signal name</b>	<b>1 signal</b>	<b>0 signal</b>	<b>FP</b>
	00	Controlled start	Yes	No	-
	01	Controlled through 0 Hz	Yes	No	-
	02	Closed-loop ctrl oper. down to zero freq. for passive loads	Yes	No	-
	03	Motor model Lh_pre = f(PsiEst)	Yes	No	-
	06	Closed-loop/open-loop controlled (PMSM) for a blocked motor	Yes	No	-
	07	Use rugged changeover limits	Yes	No	-
	08	Closed-loop controlled until wait time p1758 has expired	Yes	No	-

**Dependency:** See also: p0500

**⚠ CAUTION**  
 Do not use bit 6 = 1 if the motor can be slowly reversed by the load at the torque limit. Long delay times due to blocking (p2177 > p1758) can cause the motor to stall. In this case you should deactivate the function or use closed-loop control throughout the speed range (note the information re bit 2 = 1).

**Note**

Bits 0 ... 2 only have an influence for sensorless vector control, bit 2 is pre-assigned depending on p0500.

For bit 2 = 1:

The sensorless vector control is effective down to zero frequency. A change is not made into the open-loop speed controlled mode.

This operating mode is possible for passive loads. These include applications where the load itself does not generate any active torque and therefore only acts reactively to the drive torque of the induction motor.

If bit 2 = 1, then bit 3 is automatically set to 1. Manual de-selection is possible and may be sensible if the saturation characteristic (p1960) was not measured for third-party motors. Generally, for standard SIEMENS motors, the already pre-assigned (default value) saturation characteristic is adequate.

When the bit is set, the selection of bits 0 and 1 is ignored.

For bit 2 = 0:

Bit 3 is also automatically deactivated.

For bit 6 = 1:

The following applies for sensorless vector control of induction motors:

For a blocked motor (see p2175, p2177) the time condition in p1758 is bypassed and a change is not made into open-loop controlled operation.

For bit 7 = 1:

The following applies for sensorless vector control of induction motors:

If the changeover limits are parameterized too low (p1755, p1756), then they are automatically increased to rugged values by the absolute amount  $p1749 * p1755$ .

The effective time condition for changing over into open-controlled operation is obtained from the minimum value of p1758 and  $0.5 * r0384$ .

Is recommended that bit 7 is activated for applications that demand a high torque at low frequencies, and at the same time require low speed gradients..

Adequate parameterization of the current setpoint must be ensured (p1610, p1611).

For bit 8 = 1: no influence on the functionality of bits 0, 1, 2

The following applies for sensorless vector control of induction motors:

Changeover into open-loop speed controlled operation is no longer dependent on the speed setpoint (except for OFF3), but instead is essentially dependent on time condition p1758. As a consequence, a drive can be started or reversed in closed-loop speed controlled operation with setpoints from an external control system, if these briefly lie in the open-loop speed control range.

**p1755[0...n]****Motor model changeover speed encoderless operation / MotMod n\_chgSnsorl**

**Access level:** 3

**Calculated:** CALC\_MOD\_REG **Data type:** FloatingPoint32

**Can be changed:** T, U

**Scaling:** -

**Dynamic index:** DDS, p0180

**Unit group:** 3\_1

**Unit selection:** p0505

**Function diagram:** -

**Min:**

**Max:**

**Factory setting:**

0.00 [rpm]

210000.00 [rpm]

210000.00 [rpm]

**Description:**

Sets the speed to change over the motor model to encoderless operation.

**Dependency:**

See also: p1756

**NOTICE**

The changeover speed represents the steady-state minimum speed up to which the motor model can be used in sensorless steady-state operation.

If the stability is not adequate close to the changeover speed, it may make sense to increase the parameter value. On the other hand, very low changeover speeds can negatively impact the stability.

**Note**

The changeover speed applies for the changeover between open-loop and closed-loop control mode.

---

<b>p1756</b>	<b>Motor model changeover speed hysteresis encoderless operation / MotMod n_chgov hys</b>		
<b>Access level:</b> 3	<b>Calculated:</b> CALC_MOD_REG	<b>Data type:</b> FloatingPoint32	
<b>Can be changed:</b> T, U	<b>Scaling:</b> -	<b>Dynamic index:</b> -	
<b>Unit group:</b> -	<b>Unit selection:</b> -	<b>Function diagram:</b> 6730, 6731	
<b>Min:</b> 0.0 [%]	<b>Max:</b> 95.0 [%]	<b>Factory setting:</b> 50.0 [%]	

**Description:** Sets the hysteresis for the changeover speed of the motor model for encoderless operation.

**Dependency:** See also: p1755

---

**Note**

The parameter value refers to p1755.

Extremely small hystereses can have a negative impact on the stability in the changeover speed range, and very high hystereses in the standstill range.

---



---

<b>p1780[0...n]</b>	<b>Motor model adaptation configuration / MotMod adapt conf</b>		
CUG120X_PN (PM330)	<b>Access level:</b> 3	<b>Calculated:</b> CALC_MOD_CON	<b>Data type:</b> Unsigned16
	<b>Can be changed:</b> T, U	<b>Scaling:</b> -	<b>Dynamic index:</b> DDS, p0180
	<b>Unit group:</b> -	<b>Unit selection:</b> -	<b>Function diagram:</b> -
	<b>Min:</b> -	<b>Max:</b> -	<b>Factory setting:</b> 0000 1000 0001 0100 bin

**Description:** Sets the configuration for the adaptation circuit of the motor model.

Induction motor (ASM):

Rs, Lh and offset compensation.

<b>Bit field:</b>	<b>Bit</b>	<b>Signal name</b>	<b>1 signal</b>	<b>0 signal</b>	<b>FP</b>
	01	Select motor model ASM Rs adaptation	Yes	No	-
	02	Select motor model ASM Lh adaptation	Yes	No	-
	04	Select motor model offset adaptation	Yes	No	-
	07	Select T(valve) with Rs adaptation	Yes	No	-
	10	Filter time combination current like current ctrl integral time	Yes	No	-
	11	Fast flying restart with voltage model for induction motor	Yes	No	-

**Dependency:** In the U/f characteristic operating mode, only bit 7 and bit 11 are relevant.

For active motor model feedback (see p1784), the Lh adaptation is internally deactivated automatically.

---

**Note**

When selecting the compensation of the valve interlocking via Rs (bit 7), the compensation in the gating unit is deactivated and is instead taken into account in the motor model.

In order that the correction values of the Rs and Lh adaptation (selected using bit 0 ... bit 1) are correctly accepted when changing over the drive data set, a dedicated motor number must be entered into p0826 for each different motor.

ASM: Induction motor

RESM: synchronous reluctance motor

---



---

<b>p1800[0...n]</b>	<b>Pulse frequency setpoint / Pulse freq setp</b>		
	<b>Access level:</b> 2	<b>Calculated:</b> -	<b>Data type:</b> FloatingPoint32
	<b>Can be changed:</b> T, U	<b>Scaling:</b> -	<b>Dynamic index:</b> DDS, p0180
	<b>Unit group:</b> -	<b>Unit selection:</b> -	<b>Function diagram:</b> 8021
	<b>Min:</b> 0.500 [kHz]	<b>Max:</b> 16.000 [kHz]	<b>Factory setting:</b> 4.000 [kHz]

**Description:** Sets the pulse frequency for the converter.

This parameter is pre-set to the rated converter value when the drive is first commissioned.

**Dependency:** Minimum pulse frequency:  $p1800 \geq 12 * p1082 * r0313 / 60$

See also: p0230

**Note**

The maximum and minimum possible pulse frequency is also determined by the power unit being used (minimum pulse frequency: 2 kHz or 4 kHz).

When the pulse frequency is increased, depending on the particular power unit, the maximum output current can be reduced (derating, refer to r0067).

If a sine-wave filter is parameterized as output filter (p0230 = 3), then the pulse frequency cannot be set below the minimum value required for the filter.

For operation with output reactors, the pulse frequency is limited to 4 kHz (see p0230).

If p1800 is changed during commissioning (p0010 > 0), then it is possible that the old value will no longer be able to be set. The reason for this is that the dynamic limits of p1800 have been changed by a parameter that was set when the drive was commissioned (e.g. p1082).

The pulse frequency cannot be changed when the motor data identification is activated.

**p1800[0...n]**

CUG120X\_PN  
(PM330)

**Pulse frequency setpoint / Pulse freq setp**

**Access level:** 2

**Can be changed:** T, U

**Unit group:** -

**Min:**

0.500 [kHz]

**Calculated:** -

**Scaling:** -

**Unit selection:** -

**Max:**

4.000 [kHz]

**Data type:** FloatingPoint32

**Dynamic index:** DDS, p0180

**Function diagram:** 8021

**Factory setting:**

4.000 [kHz]

**Description:**

Sets the drive converter switching frequency.

This parameter is pre-set to twice the rated converter value when the drive is first commissioned.

**Dependency:**

Minimum pulse frequency:  $p1800 \geq 12 * p1082 * r0313 / 60$

See also: p0230

**Note**

The maximum and minimum possible pulse frequency is also determined by the power unit being used (minimum pulse frequency: 2 kHz or 4 kHz).

When the pulse frequency is increased, depending on the particular power unit, the maximum output current can be reduced (derating, refer to r0067).

If a sine-wave filter is parameterized as output filter (p0230 = 3), then the pulse frequency cannot be set below the minimum value required for the filter.

For operation with output reactors, the pulse frequency is limited to 4 kHz (see p0230).

If p1800 is changed during commissioning (p0010 > 0), then it is possible that the old value will no longer be able to be set. The reason for this is that the dynamic limits of p1800 have been changed by a parameter that was set when the drive was commissioned (e.g. p1082).

The pulse frequency cannot be changed when the motor data identification is activated.

**r1801[0...1]****CO: Pulse frequency / Pulse frequency**

**Access level:** 2

**Can be changed:** -

**Unit group:** -

**Min:**

- [kHz]

**Calculated:** -

**Scaling:** p2000

**Unit selection:** -

**Max:**

- [kHz]

**Data type:** FloatingPoint32

**Dynamic index:** -

**Function diagram:** -

**Factory setting:**

- [kHz]

**Description:**

Display and connector output for the actual converter switching frequency.

**Index:**

[0] = Actual

[1] = Modulator minimum value

**Note**

The selected pulse frequency (p1800) may be reduced if the drive converter has an overload condition (p0290).

<b>p1802[0...n]</b>	<b>Modulator mode / Modulator mode</b>		
	<b>Access level:</b> 3	<b>Calculated:</b> CALC_MOD_LIM_REF	<b>Data type:</b> Integer16
	<b>Can be changed:</b> T	<b>Scaling:</b> -	<b>Dynamic index:</b> DDS, p0180
	<b>Unit group:</b> -	<b>Unit selection:</b> -	<b>Function diagram:</b> -
	<b>Min:</b> 0	<b>Max:</b> 10	<b>Factory setting:</b> 0
<b>Description:</b>	Sets the modulator mode.		
<b>Value:</b>	0: Automatic changeover SVM/FLB 2: Space vector modulation (SVM) 3: SVM without overcontrol 4: SVM/FLB without overcontrol 10: SVM/FLB with modulation depth reduction		
<b>Dependency:</b>	If a sine-wave filter is parameterized as output filter (p0230 = 3, 4), then only space vector modulation without overcontrol can be selected as modulation type (p1802 = 3). This does not apply to power units PM260. p1802 = 10 can only be set for power units PM230 and PM240 and for r0204.15 = 0. See also: p0230, p0500		
	<b>Note</b>		
	When modulation modes are enabled that could lead to overmodulation (p1802 = 0, 2, 10), the modulation depth must be limited using p1803 (default, p1803 < 100 %). The higher the overmodulation, the greater the current ripple and torque ripple. When changing p1802[x], the values for all of the other existing indices are also changed.		
<b>p1803[0...n]</b>	<b>Maximum modulation depth / Modulat depth max</b>		
	<b>Access level:</b> 3	<b>Calculated:</b> CALC_MOD_LIM_REF	<b>Data type:</b> FloatingPoint32
	<b>Can be changed:</b> T, U	<b>Scaling:</b> -	<b>Dynamic index:</b> DDS, p0180
	<b>Unit group:</b> -	<b>Unit selection:</b> -	<b>Function diagram:</b> 6723
	<b>Min:</b> 20.0 [%]	<b>Max:</b> 150.0 [%]	<b>Factory setting:</b> 106.0 [%]
<b>Description:</b>	Defines the maximum modulation depth.		
<b>Dependency:</b>	See also: p0500		
	<b>Note</b>		
	p1803 = 100% is the overcontrol limit for space vector modulation (for an ideal drive converter without any switching delay).		
<b>p1806[0...n]</b>	<b>Filter time constant Vdc correction / T_filt Vdc_corr</b>		
	<b>Access level:</b> 3	<b>Calculated:</b> CALC_MOD_REG	<b>Data type:</b> FloatingPoint32
	<b>Can be changed:</b> T, U	<b>Scaling:</b> -	<b>Dynamic index:</b> DDS, p0180
	<b>Unit group:</b> -	<b>Unit selection:</b> -	<b>Function diagram:</b> -
	<b>Min:</b> 0.0 [ms]	<b>Max:</b> 10000.0 [ms]	<b>Factory setting:</b> 0.0 [ms]
<b>Description:</b>	Sets the filter time constant for the DC link voltage. This time constant is used to calculate the modulation depth.		



<b>p1810</b>	<b>Modulator configuration / Modulator config</b>				
	<b>Access level:</b> 3	<b>Calculated:</b> -	<b>Data type:</b> Unsigned16		
	<b>Can be changed:</b> T, U	<b>Scaling:</b> -	<b>Dynamic index:</b> -		
	<b>Unit group:</b> -	<b>Unit selection:</b> -	<b>Function diagram:</b> -		
	<b>Min:</b>	<b>Max:</b>	<b>Factory setting:</b>		
	-	-	0000 bin		
<b>Description:</b>	Sets the configuration for the modulator.				
<b>Bit field:</b>	<b>Bit</b>	<b>Signal name</b>	<b>1 signal</b>	<b>0 signal</b>	<b>FP</b>
	00	Avg value filter for V_lim (only for Vdc_comp in modulator)	Yes	No	-
	01	DC link voltage compensation in the current control	Yes	No	-
<b>NOTICE</b>					
Bit 1 = 1 can only be set under a pulse inhibit and for r0192.14 = 1.					
<b>Note</b>					
For bit 00 = 0:					
Voltage limitation from the minimum of the DC link voltage (lower ripple in the output current, reduced output voltage).					
For bit 00 = 1:					
Voltage limitation from averaged DC link voltage (higher output voltage with increased ripple in the output current).					
The selection is only valid if the DC link compensation is not performed in the Control Unit (bit 1 = 0).					
For bit 01 = 0:					
DC link voltage compensation in the modulator.					
For bit 01 = 1:					
DC link voltage compensation in the current control.					

<b>p1820[0...n]</b>	<b>Reverse the output phase sequence / Outp_ph_seq rev</b>			
	<b>Access level:</b> 2	<b>Calculated:</b> -	<b>Data type:</b> Integer16	
	<b>Can be changed:</b> T	<b>Scaling:</b> -	<b>Dynamic index:</b> DDS, p0180	
	<b>Unit group:</b> -	<b>Unit selection:</b> -	<b>Function diagram:</b> -	
	<b>Min:</b>	<b>Max:</b>	<b>Factory setting:</b>	
	0	1	0	
<b>Description:</b>	Sets the phase sequence reversal for the motor without setpoint change.			
	If the motor does not rotate in the required direction, then the output phase sequence can be reversed using this parameter. This means that the direction of the motor is reversed without the setpoint being changed.			
<b>Value:</b>	0:	OFF		
	1:	ON		
<b>Note</b>				
This setting can only be changed when the pulses are inhibited.				

<b>r1838.0...15</b>	<b>CO/BO: Gating unit status word 1 / Gating unit ZSW1</b>				
	<b>Access level:</b> 3	<b>Calculated:</b> -	<b>Data type:</b> Unsigned16		
	<b>Can be changed:</b> -	<b>Scaling:</b> -	<b>Dynamic index:</b> -		
	<b>Unit group:</b> -	<b>Unit selection:</b> -	<b>Function diagram:</b> -		
	<b>Min:</b>	<b>Max:</b>	<b>Factory setting:</b>		
	-	-	-		
<b>Description:</b>	Display and BICO output for status word 1 of the power unit.				
<b>Bit field:</b>	<b>Bit</b>	<b>Signal name</b>	<b>1 signal</b>	<b>0 signal</b>	<b>FP</b>
	00	Fault time-critical	ON	OFF	-
	01	Gating unit mode bit 0	ON	OFF	-
	02	Pulse enable	ON	OFF	-
	03	Switch-off signal path STO_B	Inactive	Active	-

7.3 Parameter list

04	Switch-off signal path STO_A	Inactive	Active	-
05	Gating unit mode bit 1	ON	OFF	-
06	Gating unit mode bit 2	ON	OFF	-
07	Brake state	ON	OFF	-
08	Brake diagnostics	ON	OFF	-
09	Armature short-circuit braking	Active	Not active	-
10	Gating unit state bit 0	ON	OFF	-
11	Gating unit state bit 1	ON	OFF	-
12	Gating unit state bit 2	ON	OFF	-
13	Alarm status bit 0	ON	OFF	-
14	Alarm status bit 1	ON	OFF	-
15	Diagnostics 24 V	ON	OFF	-

**p1900**

**Motor data identification and rotating measurement / MotID and rot meas**

<b>Access level:</b> 2	<b>Calculated:</b> -	<b>Data type:</b> Integer16
<b>Can be changed:</b> C2(1), T	<b>Scaling:</b> -	<b>Dynamic index:</b> -
<b>Unit group:</b> -	<b>Unit selection:</b> -	<b>Function diagram:</b> -
<b>Min:</b> 0	<b>Max:</b> 12	<b>Factory setting:</b> 0

**Description:**

Sets the motor data identification and speed controller optimization.

The motor identification should first be performed with the motor stationary (p1900 = 1, 2; also refer to p1910). Based on this, additional motor and control parameters can be determined using the motor data identification with the motor rotating (p1900 = 1, 3; also refer to p1960; not for p1300 < 20).

p1900 = 0:  
Function inhibited.

p1900 = 1:  
Sets p1910 = 1 and p1960 = 0, 1 depending on p1300  
When the drive enable signals are present, a motor data identification routine is carried out at standstill with the next switch-on command. Current flows through the motor which means that it can align itself by up to a quarter of a revolution.  
With the following switch-on command, a rotating motor data identification routine is carried out - and in addition, a speed controller optimization by making measurements at different motor speeds.

p1900 = 2:  
Sets p1910 = 1 and p1960 = 0  
When the drive enable signals are present, a motor data identification routine is carried out at standstill with the next switch-on command. Current flows through the motor which means that it can align itself by up to a quarter of a revolution.

p1900 = 3:  
Sets p1960 = 0, 1 depending on p1300  
This setting should only be selected if the motor data identification was already carried out at standstill.  
When the drive enable signals are present, with the next switch-on command, a rotating motor data identification routine is carried out - and in addition, speed controller optimization by taking measurements at different motor speeds.

p1900 = 11, 12:  
The same as p1900 = 1, 2 with the difference, that after the measurement, the system immediately goes into operation. For this purpose, p1909.18 is set = p1959.13 is set = 1 .

**Value:**

- 0: Inhibited
- 1: Identifying motor data and optimizing the speed controller
- 2: Identifying motor data (at standstill)
- 3: Optimizing the speed controller (in rotating operation)
- 11: Motor data ident. and speed controller opt., switch to operation
- 12: Motor data identification (at standstill), switch to operation

**Dependency:** See also: p1300, p1910, p1960  
See also: A07980, A07981, F07983, F07984, F07985, F07986, F07988, F07990, A07991

NOTICE
<p>p1900 = 3: This setting should only be selected if the motor data identification was already carried out at standstill. To permanently accept the determined settings they must be saved in a non-volatile fashion (p0971). During the rotating measurement it is not possible to save the parameter (p0971).</p>

**Note**

The motor and control parameters of the vector control are only optimally set when both measurements are carried out (initially at standstill, and then with the motor rotating). The measurement with rotating motor is not performed for p1300 < 20 (U/f controls).

An appropriate alarm is output when the parameter is set.

The switch-on command must remain set during a measurement and after the measurement has been completed, the drive automatically resets it.

The duration of the measurements can lie between 0.3 s and several minutes. This time is, for example, influenced by the motor size and the mechanical conditions.

p1900 is automatically set to 0 after the motor data identification routine has been completed.

If a reluctance motor has been parameterized, a pole position identification is carried out during the stationary measurement. As a consequence, faults that occur can also be assigned to the pole position identification.

For U/f control (p1300), identification with speed controller optimization does not make sense (e.g. P1900 = 1).

**p1900**

CUG120X\_PN  
(PM330)

**Motor data identification and rotating measurement / MotID and rot meas**

**Access level:** 2

**Calculated:** -

**Data type:** Integer16

**Can be changed:** C2(1), T

**Scaling:** -

**Dynamic index:** -

**Unit group:** -

**Unit selection:** -

**Function diagram:** -

**Min:**

**Max:**

**Factory setting:**

0

12

2

**Description:**

Sets the motor data identification and speed controller optimization.

The motor identification should first be performed with the motor stationary (p1900 = 1, 2; also refer to p1910). Based on this, additional motor and control parameters can be determined using the motor data identification with the motor rotating (p1900 = 1, 3; also refer to p1960).

p1900 = 0:

Function inhibited.

p1900 = 1:

Sets p1910 = 1 and p1960 = 0, 1 depending on p1300

When the drive enable signals are present, a motor data identification routine is carried out at standstill with the next switch-on command. Current flows through the motor which means that it can align itself by up to a quarter of a revolution.

With the following switch-on command, a rotating motor data identification routine is carried out - and in addition, a speed controller optimization by making measurements at different motor speeds.

p1900 = 2:

Sets p1910 = 1 and p1960 = 0

When the drive enable signals are present, a motor data identification routine is carried out at standstill with the next switch-on command. Current flows through the motor which means that it can align itself by up to a quarter of a revolution.

p1900 = 3:

Sets p1960 = 0, 1 depending on p1300

This setting should only be selected if the motor data identification was already carried out at standstill.

When the drive enable signals are present, with the next switch-on command, a rotating motor data identification routine is carried out - and in addition, speed controller optimization by taking measurements at different motor speeds.

p1900 = 11, 12:

The same as p1900 = 1, 2 with the difference, that after the measurement, the system immediately goes into operation. For this purpose, p1909.18 is set = p1959.13 is set = 1 .

**Value:**

0: Inhibited



<b>p1901</b>	<b>Test pulse evaluation configuration / Test puls config</b>				
CUG120X_PN (PM330)	<b>Access level:</b> 3	<b>Calculated:</b> CALC_MOD_ALL	<b>Data type:</b> Unsigned32		
	<b>Can be changed:</b> T	<b>Scaling:</b> -	<b>Dynamic index:</b> -		
	<b>Unit group:</b> -	<b>Unit selection:</b> -	<b>Function diagram:</b> -		
	<b>Min:</b>	<b>Max:</b>	<b>Factory setting:</b>		
	-	-	0000 bin		
<b>Description:</b>	Sets the configuration for the test pulse evaluation. Bit 00: Check for conductor-to-conductor short circuit once/always when the pulses are enabled. Bit 01: Check for ground fault once/always when the pulses are enabled. Bit 02: Activation of the tests selected using bit 00 and/or bit 01 each time the pulses are enabled				
<b>Recommendation:</b>	If the ground fault test is incorrectly initiated because the motor is not at a complete standstill, then the pulse cancellation delay time (p1228) should be increased.				
<b>Bit field:</b>	<b>Bit</b>	<b>Signal name</b>	<b>1 signal</b>	<b>0 signal</b>	<b>FP</b>
	00	Phase short-circuit test pulse active	Yes	No	-
	01	Ground fault detection test pulse active	Yes	No	-
	02	Test pulse at each pulse enable	Yes	No	-
<b>Dependency:</b>	The ground fault test is only possible when the motor is stationary, and is therefore only realized when flying restart is deactivated (p1200 = 0). See also: p0287				

**Note**

If a conductor-to-conductor short-circuit is detected during the test, this is displayed in r1902.1.

If a ground fault is detected during the test, this is displayed in r1902.2.

For bit 02 = 0:

If the test was successful once after POWER ON (see r1902.0), then it is not repeated.

For bit 02 = 1:

The test is not only performed after POWER ON, but also each time the pulses are enabled.

For chassis power units, the ground fault is also determined using the summed output current (see p0287).

<b>p1909[0...n]</b>	<b>Motor data identification control word / MotID STW</b>			
	<b>Access level:</b> 3	<b>Calculated:</b> CALC_MOD_ALL	<b>Data type:</b> Unsigned32	
	<b>Can be changed:</b> T	<b>Scaling:</b> -	<b>Dynamic index:</b> MDS, p0130	
	<b>Unit group:</b> -	<b>Unit selection:</b> -	<b>Function diagram:</b> -	
	<b>Min:</b>	<b>Max:</b>	<b>Factory setting:</b>	
	-	-	0000 0000 0000 0000 0000 0000 0000 0000 bin	

**Description:** Sets the configuration for the motor data identification.

<b>Bit field:</b>	<b>Bit</b>	<b>Signal name</b>	<b>1 signal</b>	<b>0 signal</b>	<b>FP</b>
	00	Stator inductance estimate no measurement	Yes	No	-
	02	Rotor time constant estimate no measurement	Yes	No	-
	03	Leakage inductance estimate no measurement	Yes	No	-
	05	Determine Tr and Lsig evaluation in the time range	Yes	No	-
	06	Activate vibration damping	Yes	No	-
	07	Deactivate vibration detection	Yes	No	-
	11	Deactivate pulse measurement Lq Ld	Yes	No	-
	12	Deactivate rotor resistance Rr measurement	Yes	No	-
	14	Deactivate valve interlocking time measurement	Yes	No	-
	15	Determine only stator resistance, valve voltage fault, dead time	Yes	No	-
	16	Short motor identification (lower quality)	Yes	No	-
	17	Measurement without control parameter calculation	Yes	No	-

7.3 Parameter list

18	After motID direct transition into operation	Yes	No	-
19	After MotID automatically save results	Yes	No	-
20	Estimate cable resistance	Yes	No	-
21	Calibrating the output voltage measurement	Yes	No	-
22	Only identify circle	Yes	No	-
23	Deactivate circle identification	Yes	No	-
24	Circle identification with 0 and 90 degrees	Yes	No	-

**Note**

The following applies to permanent-magnet synchronous motors:

Without de-selection in bit 11, in the closed-loop control mode, the direct inductance LD and the quadrature inductance Lq are measured at a low current.

When de-selecting with bit 11 or in the U/f mode, the stator inductance is measured at half the rated motor current.

If the stator inductance is not measured but is to be estimated, then bit 0 should be set and bit 11 should be de-selected.

Bit 19 = 1:

All parameters are automatically saved after a successful motor data identification.

If a speed controller optimization run is then selected, the parameters are only saved after this measurement has been completed.

Bit 22 ... 24: only for reluctance motors

Bit 22 = 1:

Only that measurement is carried out that is required for the flying restart of a reluctance motor. The bit is reset after a successful measurement

**p1909[0...n]**

CUG120X\_PN  
(PM330)

**Motor data identification control word / MotID STW**

**Access level:** 3

**Calculated:** CALC\_MOD\_ALL **Data type:** Unsigned32

**Can be changed:** T

**Scaling:** -

**Dynamic index:** MDS, p0130

**Unit group:** -

**Unit selection:** -

**Function diagram:** -

**Min:**

**Max:**

**Factory setting:**

-

-

0000 0000 0000 0000 0000  
0000 0000 0000 bin

**Description:**

Sets the configuration for the motor data identification.

**Bit field:**

Bit	Signal name	1 signal	0 signal	FP
00	Stator inductance estimate no measurement	Yes	No	-
02	Rotor time constant estimate no measurement	Yes	No	-
03	Leakage inductance estimate no measurement	Yes	No	-
05	Determine Tr and Lsig evaluation in the time range	Yes	No	-
06	Activate vibration damping	Yes	No	-
07	Deactivate vibration detection	Yes	No	-
11	Deactivate pulse measurement Lq Ld	Yes	No	-
12	Deactivate rotor resistance Rr measurement	Yes	No	-
14	Deactivate valve interlocking time measurement	Yes	No	-
15	Determine only stator resistance, valve voltage fault, dead time	Yes	No	-
16	Short motor identification (lower quality)	Yes	No	-
17	Measurement without control parameter calculation	Yes	No	-
18	After motID direct transition into operation	Yes	No	-
19	After MotID automatically save results	Yes	No	-
20	Estimate cable resistance	Yes	No	-
21	Calibrating the output voltage measurement	Yes	No	-

**Note**

The following applies to permanent-magnet synchronous motors:

Without de-selection in bit 11, in the closed-loop control mode, the direct inductance LD and the quadrature inductance Lq are measured at a low current.

When de-selecting with bit 11 or in the U/f mode, the stator inductance is measured at half the rated motor current.

If the stator inductance is not measured but is to be estimated, then bit 0 should be set and bit 11 should be de-selected.

For bit 19 = 1:

All parameters are automatically saved after a successful motor data identification.

If a speed controller optimization run is then selected, the parameters are only saved after this measurement has been completed.

For bit 21 = 1:

The converter output voltage measurement is calibrated at the start of the motor data identification.

**p1910****Motor data identification selection / MotID selection**

**Access level:** 3

**Calculated:** -

**Data type:** Integer16

**Can be changed:** T

**Scaling:** -

**Dynamic index:** -

**Unit group:** -

**Unit selection:** -

**Function diagram:** -

**Min:**

**Max:**

**Factory setting:**

0

28

0

**Description:**

Sets the motor data identification routine.

The motor data identification routine is carried out after the next switch-on command.

p1910 = 1:

All motor data and the drive converter characteristics are identified and then transferred to the following parameters:

p0350, p0354, p0356, p0357, p0358, p0360, p1825, p1828, p1829, p1830

After this, the control parameter p0340 = 3 is automatically calculated.

p1910 = 20:

Only for internal SIEMENS use.

**Value:**

0: Inhibited

1: Complete identification (ID) and acceptance of motor data

2: Complete identification (ID) of motor data without acceptance

20: Voltage vector input

21: Voltage vector input without filter

22: Rectangular voltage vector input without filter

23: Triangular voltage vector input without filter

24: Rectangular voltage vector input with filter

25: Triangular voltage vector input with filter

26: Enter voltage vector with DTC correction

27: Enter voltage vector with AVC

28: Enter voltage vector with DTC + AVC correction

**Dependency:**

"Quick commissioning" must be carried out (p0010 = 1, p3900 > 0) before executing the motor data identification routine!

When selecting the motor data identification routine, the drive data set changeover is suppressed.

See also: p1900

See also: F07990, A07991

**NOTICE**

After the motor data identification (p1910 > 0) has been selected, alarm A07991 is output and a motor data identification routine is carried out as follows at the next switch-on command:

- current flows through the motor and a voltage is present at the drive converter output terminals.
- during the identification routine, the motor shaft can rotate through a maximum of half a revolution.
- however, no torque is generated.

**Note**

To permanently accept the determined settings they must be saved in a non-volatile fashion (p0971).

When setting p1910, the following should be observed:

1. "With acceptance" means:

The parameters specified in the description are overwritten with the identified values and therefore have an influence on the controller setting.

2. "Without acceptance" means:

The identified parameters are only displayed in the range r1912 ... r1926 (service parameters). The controller settings remain unchanged.

3. For settings 27 and 28, the AVC configuration set using p1840 is active.

The switch-on command must remain set during a measurement and after the measurement has been completed, the drive automatically resets it. The duration of the measurements can lie between 0.3 s and several minutes. This time is mainly influenced by the motor size. At the end of the motor data identification, p1910 is automatically set to 0, if only the stationary measurement is selected, then p1900 is also reset to 0, otherwise, the rotating measurement is activated.

**p1910**

CUG120X\_PN  
(PM330)

**Motor data identification selection / MotID selection**

**Access level:** 3

**Calculated:** -

**Data type:** Integer16

**Can be changed:** T

**Scaling:** -

**Dynamic index:** -

**Unit group:** -

**Unit selection:** -

**Function diagram:** -

**Min:**

**Max:**

**Factory setting:**

0

28

1

**Description:**

Sets the motor data identification routine.

The motor data identification routine is carried out after the next switch-on command.

p1910 = 1:

All motor data and the drive converter characteristics are identified and then transferred to the following parameters:

p0350, p0354, p0356, p0357, p0358, p0360, p1825, p1828, p1829, p1830

After this, the control parameter p0340 = 3 is automatically calculated.

p1910 = 20:

Only for internal SIEMENS use.

**Value:**

0: Inhibited

1: Complete identification (ID) and acceptance of motor data

2: Complete identification (ID) of motor data without acceptance

20: Voltage vector input

21: Voltage vector input without filter

22: Rectangular voltage vector input without filter

23: Triangular voltage vector input without filter

24: Rectangular voltage vector input with filter

25: Triangular voltage vector input with filter

26: Enter voltage vector with DTC correction

27: Enter voltage vector with AVC

28: Enter voltage vector with DTC + AVC correction

**Dependency:**

"Quick commissioning" must be carried out (p0010 = 1, p3900 > 0) before executing the motor data identification routine!

When selecting the motor data identification routine, the drive data set changeover is suppressed.

See also: p1900

See also: F07990, A07991

**NOTICE**

After the motor data identification (p1910 > 0) has been selected, alarm A07991 is output and a motor data identification routine is carried out as follows at the next switch-on command:

- current flows through the motor and a voltage is present at the drive converter output terminals.
- during the identification routine, the motor shaft can rotate through a maximum of half a revolution.
- however, no torque torque is generated.



**Note**

To permanently accept the determined settings they must be saved in a non-volatile fashion (p0971).

When setting p1910, the following should be observed:

1. "With acceptance" means:

The parameters specified in the description are overwritten with the identified values and therefore have an influence on the controller setting.

2. "Without acceptance" means:

The identified parameters are only displayed in the range r1912 ... r1926 (service parameters). The controller settings remain unchanged.

3. For settings 27 and 28, the AVC configuration set using p1840 is active.

The switch-on command must remain set during a measurement and after the measurement has been completed, the drive automatically resets it. The duration of the measurements can lie between 0.3 s and several minutes. This time is mainly influenced by the motor size. At the end of the motor data identification, p1910 is automatically set to 0, if only the stationary measurement is selected, then p1900 is also reset to 0, otherwise, the rotating measurement is activated.

<b>p1959[0...n]</b>	<b>Rotating measurement configuration / Rot meas config</b>				
	<b>Access level:</b> 3	<b>Calculated:</b> CALC_MOD_ALL	<b>Data type:</b> Unsigned16		
	<b>Can be changed:</b> T	<b>Scaling:</b> -	<b>Dynamic index:</b> DDS, p0180		
	<b>Unit group:</b> -	<b>Unit selection:</b> -	<b>Function diagram:</b> -		
	<b>Min:</b>	<b>Max:</b>	<b>Factory setting:</b>		
	-	-	0000 0000 0001 1110 bin		
<b>Description:</b>	Sets the configuration of the rotating measurement.				
<b>Bit field:</b>	<b>Bit</b>	<b>Signal name</b>	<b>1 signal</b>	<b>0 signal</b>	<b>FP</b>
	01	Saturation characteristic identification	Yes	No	-
	02	Moment of inertia identification	Yes	No	-
	03	Re-calculates the speed controller parameters	Yes	No	-
	04	Speed controller optimization (vibration test)	Yes	No	-
	11	Do not change the controller parameters during the measurement	Yes	No	-
	12	Measurement shortened	Yes	No	-
	13	After measurement direct transition into operation	Yes	No	-
	14	Calculate speed actual value smoothing time	Yes	No	-
<b>Dependency:</b>	See also: F07988				

**Note**

The following parameters are influenced for the individual optimization steps:

Bit 01: p0320, p0360, p0362 ... p0369

Bit 02: p0341, p0342

Bit 03: p1400.0, p1458, p1459, p1463, p1470, p1472, p1496

Bit 04: Dependent on p1960

p1960 = 1, 3: p1400.0, p1458, p1459, p1470, p1472, p1496

<b>p1959[0...n]</b>	<b>Rotating measurement configuration / Rot meas config</b>				
CUG120X_PN (PM330)	<b>Access level:</b> 3	<b>Calculated:</b> CALC_MOD_ALL	<b>Data type:</b> Unsigned16		
	<b>Can be changed:</b> T	<b>Scaling:</b> -	<b>Dynamic index:</b> DDS, p0180		
	<b>Unit group:</b> -	<b>Unit selection:</b> -	<b>Function diagram:</b> -		
	<b>Min:</b>	<b>Max:</b>	<b>Factory setting:</b>		
	-	-	0001 0000 0001 1110 bin		
<b>Description:</b>	Sets the configuration of the rotating measurement.				
<b>Bit field:</b>	<b>Bit</b>	<b>Signal name</b>	<b>1 signal</b>	<b>0 signal</b>	<b>FP</b>
	01	Saturation characteristic identification	Yes	No	-
	02	Moment of inertia identification	Yes	No	-

7.3 Parameter list

03	Re-calculates the speed controller parameters	Yes	No	-
04	Speed controller optimization (vibration test)	Yes	No	-
11	Do not change the controller parameters during the measurement	Yes	No	-
12	Measurement shortened	Yes	No	-
13	After measurement direct transition into operation	Yes	No	-
14	Calculate speed actual value smoothing time	Yes	No	-

**Dependency:** See also: F07988

**Note**

The following parameters are influenced for the individual optimization steps:

Bit 01: p0320, p0360, p0362 ... p0369

Bit 02: p0341, p0342

Bit 03: p1400.0, p1458, p1459, p1463, p1470, p1472, p1496

Bit 04: Dependent on p1960

p1960 = 1, 3: p1400.0, p1458, p1459, p1470, p1472, p1496

For bit 12 = 1:

The selection only has an effect on the measurement p1960 = 1. For the shortened measurement, the magnetizing current and moment of inertia are determined with a somewhat lower accuracy.

**p1960**

**Rotating measurement selection / Rot meas sel**

**Access level:** 3

**Calculated:** -

**Data type:** Integer16

**Can be changed:** T

**Scaling:** -

**Dynamic index:** -

**Unit group:** -

**Unit selection:** -

**Function diagram:** -

**Min:**

**Max:**

**Factory setting:**

0

3

0

**Description:**

Sets the rotating measurement.

The rotating measurement is carried out after the next switch-on command.

The setting possibilities of the parameter depend on the open-loop/closed-loop control mode (p1300).

p1300 < 20 (U/f open-loop control):

It is not possible to select rotating measurement or speed controller optimization.

p1300 = 20, 22 (encoderless operation):

Only rotating measurement or speed controller optimization can be selected in the encoderless mode.

**Value:**

0: Inhibited

1: Rotating measurement in encoderless operation

3: Speed controller optimization in encoderless operation

**Dependency:**

Before the rotating measurement is carried out, the motor data identification routine (p1900, p1910, r3925) should have already been done.

When selecting the rotating measurement, the drive data set changeover is suppressed.

See also: p1300, p1900, p1959, p1967, r1968

<b>! DANGER</b>
For drives with a mechanical system that limits the distance moved, it must be ensured that this is not reached during the rotating measurement. If this is not the case, then it is not permissible that the measurement is carried out.

<b>NOTICE</b>
To permanently accept the determined settings they must be saved in a non-volatile fashion (p0971). During the rotating measurement it is not possible to save the parameter (p0971).

**Note**

When the rotating measurement is activated, it is not possible to save the parameters (p0971).

Parameter changes are automatically made for the rotating measurement (e.g. p1120); this is the reason that up to the end of the measurement, and if no faults are present, no manual changes should be made.

The ramp-up and ramp-down times (p1120, p1121) are limited, for the rotating measurement, to 900 s.

<b>p1961</b>	<b>Saturation characteristic speed to determine / Sat_char n determ</b>		
	<b>Access level:</b> 3	<b>Calculated:</b> -	<b>Data type:</b> FloatingPoint32
	<b>Can be changed:</b> T, U	<b>Scaling:</b> -	<b>Dynamic index:</b> -
	<b>Unit group:</b> -	<b>Unit selection:</b> -	<b>Function diagram:</b> -
	<b>Min:</b> 26 [%]	<b>Max:</b> 75 [%]	<b>Factory setting:</b> 40 [%]
<b>Description:</b>	Sets the speed to determine the saturation characteristic. The percentage value is referred to p0310 (rated motor frequency).		
<b>Dependency:</b>	See also: p0310, p1959 See also: F07983		
	<b>Note</b> The saturation characteristics should be determined at an operating point with the lowest possible load.		
<b>p1961</b>	<b>Saturation characteristic speed to determine / Sat_char n determ</b>		
CUG120X_PN (PM330)	<b>Access level:</b> 3	<b>Calculated:</b> -	<b>Data type:</b> FloatingPoint32
	<b>Can be changed:</b> T, U	<b>Scaling:</b> -	<b>Dynamic index:</b> -
	<b>Unit group:</b> -	<b>Unit selection:</b> -	<b>Function diagram:</b> -
	<b>Min:</b> 26 [%]	<b>Max:</b> 75 [%]	<b>Factory setting:</b> 30 [%]
<b>Description:</b>	Sets the speed to determine the saturation characteristic. The percentage value is referred to p0310 (rated motor frequency).		
<b>Dependency:</b>	See also: p0310, p1959 See also: F07983		
	<b>Note</b> The saturation characteristics should be determined at an operating point with the lowest possible load.		
<b>p1965</b>	<b>Speed_ctrl_opt speed / n_opt speed</b>		
	<b>Access level:</b> 3	<b>Calculated:</b> -	<b>Data type:</b> FloatingPoint32
	<b>Can be changed:</b> T, U	<b>Scaling:</b> -	<b>Dynamic index:</b> -
	<b>Unit group:</b> -	<b>Unit selection:</b> -	<b>Function diagram:</b> -
	<b>Min:</b> 10 [%]	<b>Max:</b> 75 [%]	<b>Factory setting:</b> 40 [%]
<b>Description:</b>	Sets the speed for the identification of the moment of inertia and the vibration test. Induction motor: The percentage value is referred to p0310 (rated motor frequency). Synchronous motor: The percentage value is referred to the minimum from p0310 (rated motor frequency) and p1082 (maximum speed).		
<b>Dependency:</b>	See also: p0310, p1959 See also: F07984, F07985		
	<b>Note</b> In order to calculate the inertia, sudden speed changes are carried out - the specified value corresponds to the lower speed setpoint. This value is increased by 20 % for the upper speed value. The q leakage inductance (refer to p1959.5) is determined at zero speed and at 50 % of p1965 - however, with a maximum output frequency of 15 Hz and at a minimum of 10% of the rated motor speed.		

<b>p1967</b>	<b>Speed_ctrl_opt dynamic factor / n_opt dyn_factor</b>		
	<b>Access level:</b> 3	<b>Calculated:</b> CALC_MOD_ALL	<b>Data type:</b> FloatingPoint32
	<b>Can be changed:</b> T, U	<b>Scaling:</b> -	<b>Dynamic index:</b> -
	<b>Unit group:</b> -	<b>Unit selection:</b> -	<b>Function diagram:</b> -
	<b>Min:</b> 1 [%]	<b>Max:</b> 400 [%]	<b>Factory setting:</b> 100 [%]
<b>Description:</b>	Sets the dynamic response factor for speed controller optimization. After optimization, the dynamic response achieved is displayed in r1968.		
<b>Dependency:</b>	See also: p1959, r1968 See also: F07985		
	<b>Note</b> For a rotating measurement, this parameter can be used to optimize the speed controller. p1967 = 100 % --> speed controller optimization according to a symmetric optimum. p1967 > 100 % --> optimization with a higher dynamic response (Kp higher, Tn lower). If the actual dynamic response (see r1968) is significantly reduced with respect to the required dynamic response (p1967), then this can be as a result of mechanical load oscillations. If, in spite of this load behavior, a higher dynamic response is required, then the oscillation test (p1959.4 = 0) should be deactivated and the measurement repeated.		
<b>r1968</b>	<b>Speed_ctrl_opt dynamic factor actual / n_opt dyn_fact act</b>		
	<b>Access level:</b> 3	<b>Calculated:</b> -	<b>Data type:</b> FloatingPoint32
	<b>Can be changed:</b> -	<b>Scaling:</b> -	<b>Dynamic index:</b> -
	<b>Unit group:</b> -	<b>Unit selection:</b> -	<b>Function diagram:</b> -
	<b>Min:</b> - [%]	<b>Max:</b> - [%]	<b>Factory setting:</b> - [%]
<b>Description:</b>	Displays the dynamic factor which is actually achieved for the vibration test		
<b>Dependency:</b>	See also: p1959, p1967 See also: F07985		
	<b>Note</b> This dynamic factor only refers to the control mode of the speed controller set in p1960.		
<b>p1980[0...n]</b>	<b>PolID technique / PolID technique</b>		
	<b>Access level:</b> 3	<b>Calculated:</b> CALC_MOD_REG	<b>Data type:</b> Integer16
	<b>Can be changed:</b> T, U	<b>Scaling:</b> -	<b>Dynamic index:</b> MDS, p0130
	<b>Unit group:</b> -	<b>Unit selection:</b> -	<b>Function diagram:</b> -
	<b>Min:</b> 1	<b>Max:</b> 10	<b>Factory setting:</b> 4
<b>Description:</b>	Sets the pole position identification technique. p1980 = 1, 8: The current magnitude is set using p0329. p1980 = 4, 6: The current magnitude of the first measurement section is set using p0325, the second using p0329. p1980 = 10: The rated motor current is impressed to align. The current magnitudes are limited to the rated power unit values.		
<b>Value:</b>	1: Voltage pulsing 1st harmonics 4: Voltage pulsing 2-stage 6: Voltage pulsing 2-stage inverse 8: Voltage pulsing 2nd harmonic, inverse 10: DC current injection		
<b>Dependency:</b>	See also: p1780 See also: F07969		

**Note**

Voltage pulse technique (p1980 = 1, 4, 8) cannot be applied for operation with sine-wave output filters (p0230).

**r1992.0...15****CO/BO: PolID diagnostics / PolID diag****Access level:** 3**Calculated:** -**Data type:** Unsigned16**Can be changed:** -**Scaling:** -**Dynamic index:** -**Unit group:** -**Unit selection:** -**Function diagram:** -**Min:****Max:****Factory setting:**

-

-

-

**Description:**

Display and BICO output for the diagnostics information of the pole position identification (polID)

**Bit field:**

Bit	Signal name	1 signal	0 signal	FP
00	Critical encoder fault occurred	Yes	No	-
02	Encoder parking active	Yes	No	-
05	Encoder fault Class 1	Yes	No	-
06	Encoder fault Class 2	Yes	No	-
07	Pole position identification for encoder carried out	Yes	No	-
08	Fine synchronization carried out	Yes	No	-
09	Coarse synchronization carried out	Yes	No	-
10	Commutation information available	Yes	No	-
11	Speed information available	Yes	No	-
12	Position information available	Yes	No	-
15	Zero mark passed	Yes	No	-

**Dependency:**

See also: p0325, p0329, p1980

**Note**

The data of p1992 are updated in a 4 ms cycle.

Fast changes of the encoder status word bits can be better investigated using p7830 and following.

PolID: Pole position identification

**p1998[0...n]****PolID circle center point / PolID circ center****Access level:** 3**Calculated:** CALC\_MOD\_CON **Data type:** FloatingPoint32**Can be changed:** T, U**Scaling:** -**Dynamic index:** DDS, p0180**Unit group:** -**Unit selection:** -**Function diagram:** -**Min:****Max:****Factory setting:**

0.0000 [A]

10000.0000 [A]

0.0000 [A]

**Description:**

Current offset determined to measure the speed (RESM)

**Dependency:**

See also: p1980, r1992

**p2000****Reference speed reference frequency / n\_ref f\_ref****Access level:** 2**Calculated:** CALC\_MOD\_ALL **Data type:** FloatingPoint32**Can be changed:** T**Scaling:** -**Dynamic index:** -**Unit group:** -**Unit selection:** -**Function diagram:** -**Min:****Max:****Factory setting:**

6.00 [rpm]

210000.00 [rpm]

1500.00 [rpm]

**Description:**

Sets the reference quantity for speed and frequency.

All speeds or frequencies specified as relative value are referred to this reference quantity.

The reference quantity corresponds to 100% or 4000 hex (word) or 4000 0000 hex (double word).

The following applies: Reference frequency (in Hz) = reference speed (in ((rpm) / 60) x pole pair number)

7.3 Parameter list

**Dependency:** This parameter is only updated during the automatic calculation (p0340 = 1, p3900 > 0) if motor commissioning was carried out beforehand for drive data set zero. This means that the parameter is not locked against overwriting using p0573 = 1.

See also: p2001, p2002, p2003, r2004, r3996

**NOTICE**  
When the reference speed / reference frequency is changed, short-term communication interruptions may occur.

**Note**

If a BICO interconnection is established between different physical quantities, then the particular reference quantities are used as internal conversion factor.

Example 1:

The signal of an analog input (e.g. r0755[0]) is connected to a speed setpoint (e.g. p1070[0]). The actual percentage input value is cyclically converted into the absolute speed setpoint using the reference speed (p2000).

Example 2:

The setpoint from PROFIBUS (r2050[1]) is connected to a speed setpoint (e.g. p1070[0]). The actual input value is cyclically converted into a percentage value via the pre-specified scaling 4000 hex. This percentage value is converted to the absolute speed setpoint via reference speed (p2000).

**p2001**

**Reference voltage / Reference voltage**

<b>Access level:</b> 3	<b>Calculated:</b> CALC_MOD_ALL	<b>Data type:</b> FloatingPoint32
<b>Can be changed:</b> T	<b>Scaling:</b> -	<b>Dynamic index:</b> -
<b>Unit group:</b> -	<b>Unit selection:</b> -	<b>Function diagram:</b> -
<b>Min:</b> 10 [Vrms]	<b>Max:</b> 100000 [Vrms]	<b>Factory setting:</b> 1000 [Vrms]

**Description:**

Sets the reference quantity for voltages.

All voltages specified as relative value are referred to this reference quantity. This also applies for direct voltage values (= rms value) like the DC link voltage.

The reference quantity corresponds to 100% or 4000 hex (word) or 4000 0000 hex (double word).

Note:

This reference quantity also applies to direct voltage values. It is not interpreted as rms value, but as DC voltage value.

**Dependency:**

p2001 is only updated during automatic calculation (p0340 = 1, p3900 > 0) if motor commissioning has been carried out first for drive data set zero and as a result overwriting of the parameter has not been blocked by setting p0573 = 1.

See also: r3996

**p2002**

**Reference current / I\_ref**

<b>Access level:</b> 3	<b>Calculated:</b> CALC_MOD_ALL	<b>Data type:</b> FloatingPoint32
<b>Can be changed:</b> T	<b>Scaling:</b> -	<b>Dynamic index:</b> -
<b>Unit group:</b> -	<b>Unit selection:</b> -	<b>Function diagram:</b> -
<b>Min:</b> 0.10 [Arms]	<b>Max:</b> 100000.00 [Arms]	<b>Factory setting:</b> 100.00 [Arms]

**Description:**

Sets the reference quantity for currents.

All currents specified as relative value are referred to this reference quantity.

The reference quantity corresponds to 100% or 4000 hex (word) or 4000 0000 hex (double word).

**Dependency:**

This parameter is only updated during the automatic calculation (p0340 = 1, p3900 > 0) if motor commissioning was carried out beforehand for drive data set zero. This means that the parameter is not locked against overwriting using p0573 = 1.

See also: r3996

NOTICE
<p>If various DDS are used with different motor data, then the reference quantities remain the same as these are not changed over with the DDS. The resulting conversion factor must be taken into account.</p> <p>Example:</p> <p>p2002 = 100 A Reference quantity 100 A corresponds to 100 %</p> <p>p0305[0] = 100 A Rated motor current 100 A for MDS0 in DDS0 --&gt; 100 % corresponds to 100 % of the rated motor current</p> <p>p0305[1] = 50 A Rated motor current 50 A for MDS1 in DDS1 --&gt; 100 % corresponds to 200 % of the rated motor current</p> <p>When the reference current is changed, short-term communication interruptions may occur.</p>

**Note**

Pre-assigned value is p0640.

If a BICO interconnection is established between different physical quantities, then the particular reference quantities are used as internal conversion factor.

For infeed units, the rated line current, which is obtained from the rated power and parameterized rated line supply voltage ( $p2002 = r0206 / p0210 / 1.73$ ) is pre-assigned as the reference quantity.

Example:

The actual value of a phase current (r0069[0]) is connected to a test socket (e.g. p0771[0]). The actual current value is cyclically converted into a percentage of the reference current (p2002) and output according to the parameterized scaling.

**p2003****Reference torque / M\_ref**

**Access level:** 3

**Can be changed:** T

**Unit group:** 7\_2

**Min:**

0.01 [Nm]

**Calculated:** CALC\_MOD\_ALL **Data type:** FloatingPoint32

**Scaling:** -

**Unit selection:** p0505

**Max:**

20000000.00 [Nm]

**Dynamic index:** -

**Function diagram:** -

**Factory setting:**

1.00 [Nm]

**Description:**

Sets the reference quantity for torque.

All torques specified as relative value are referred to this reference quantity.

The reference quantity corresponds to 100% or 4000 hex (word) or 4000 0000 hex (double word).

**Dependency:**

This parameter is only updated during the automatic calculation (p0340 = 1, p3900 > 0) if motor commissioning was carried out beforehand for drive data set zero. This means that the parameter is not locked against overwriting using p0573 = 1.

See also: r3996

NOTICE
<p>When the reference torque is changed, short-term communication interruptions may occur.</p>

**Note**

Preassigned value is  $2 * p0333$ .

If a BICO interconnection is established between different physical quantities, then the particular reference quantities are used as internal conversion factor.

Example:

The actual value of the total torque (r0079) is connected to a test socket (e.g. p0771[0]). The actual torque is cyclically converted into a percentage of the reference torque (p2003) and output according to the parameterized scaling.

**r2004****Reference power / P\_ref**

**Access level:** 3

**Can be changed:** -

**Unit group:** 14\_10

**Min:**

- [kW]

**Calculated:** -

**Scaling:** -

**Unit selection:** p0505

**Max:**

- [kW]

**Data type:** FloatingPoint32

**Dynamic index:** -

**Function diagram:** -

**Factory setting:**

- [kW]

7.3 Parameter list

**Description:** Displays the reference quantity for power.  
 All power ratings specified as relative value are referred to this reference quantity.  
 The reference quantity corresponds to 100% or 4000 hex (word) or 4000 0000 hex (double word).

**Dependency:** This value is calculated as follows:  
 Infeed: Calculated from voltage times current.  
 Closed-loop control: Calculated from torque times speed.  
 See also: p2000, p2001, p2002, p2003

---

**Note**  
 If a BICO interconnection is established between different physical quantities, then the particular reference quantities are used as internal conversion factor.  
 The reference power is calculated as follows:  
 -  $2 * \text{Pi} * \text{reference speed} / 60 * \text{reference torque}$  (motor)  
 -  $\text{reference voltage} * \text{reference current} * \text{root}(3)$  (infeed)

---



---

**p2006**      **Reference temperature / Ref temp**

<b>Access level:</b> 3	<b>Calculated:</b> CALC_MOD_ALL	<b>Data type:</b> FloatingPoint32
<b>Can be changed:</b> T	<b>Scaling:</b> -	<b>Dynamic index:</b> -
<b>Unit group:</b> 21_1	<b>Unit selection:</b> p0505	<b>Function diagram:</b> -
<b>Min:</b> 50.00 [°C]	<b>Max:</b> 300.00 [°C]	<b>Factory setting:</b> 100.00 [°C]

**Description:** Sets the reference quantity for temperature.  
 All temperatures specified as relative value are referred to this reference quantity.  
 The reference quantity corresponds to 100% or 4000 hex (word) or 4000 0000 hex (double word).

---

**p2010**      **Comm IF baud rate / Comm baud**

<b>Access level:</b> 3	<b>Calculated:</b> -	<b>Data type:</b> Integer16
<b>Can be changed:</b> T	<b>Scaling:</b> -	<b>Dynamic index:</b> -
<b>Unit group:</b> -	<b>Unit selection:</b> -	<b>Function diagram:</b> -
<b>Min:</b> 6	<b>Max:</b> 12	<b>Factory setting:</b> 12

**Description:** Sets the baud rate for the commissioning interface (USS, RS232).

**Value:**

6:	9600 baud
7:	19200 baud
8:	38400 baud
9:	57600 baud
10:	76800 baud
11:	93750 baud
12:	115200 baud

---

**Note**  
 COMM-IF: Commissioning interface  
 The parameter is not influenced by setting the factory setting.

---



---

**p2011**      **Comm IF address / Comm add**

<b>Access level:</b> 3	<b>Calculated:</b> -	<b>Data type:</b> Unsigned16
<b>Can be changed:</b> T	<b>Scaling:</b> -	<b>Dynamic index:</b> -
<b>Unit group:</b> -	<b>Unit selection:</b> -	<b>Function diagram:</b> -
<b>Min:</b> 0	<b>Max:</b> 31	<b>Factory setting:</b> 2

**Description:** Sets the address for the commissioning interface (USS, RS232).



**Note**

The parameter is not influenced by setting the factory setting.

<b>p2016[0...3]</b>	<b>CI: Comm IF USS PZD send word / Comm USS send word</b>				
	<b>Access level:</b> 3	<b>Calculated:</b> -	<b>Data type:</b> Unsigned32 / Integer16		
	<b>Can be changed:</b> T, U	<b>Scaling:</b> 4000H	<b>Dynamic index:</b> -		
	<b>Unit group:</b> -	<b>Unit selection:</b> -	<b>Function diagram:</b> -		
	<b>Min:</b> -	<b>Max:</b> -	<b>Factory setting:</b> 0		
<b>Description:</b>	Selects the PZD (actual values) to be sent via the commissioning interface USS. The actual values are displayed on an intelligent operator panel (IOP).				
<b>Index:</b>	[0] = PZD 1 [1] = PZD 2 [2] = PZD 3 [3] = PZD 4				
<b>p2030</b>	<b>Field bus interface protocol selection / Field bus protocol</b>				
	<b>Access level:</b> 1	<b>Calculated:</b> -	<b>Data type:</b> Integer16		
	<b>Can be changed:</b> T	<b>Scaling:</b> -	<b>Dynamic index:</b> -		
	<b>Unit group:</b> -	<b>Unit selection:</b> -	<b>Function diagram:</b> 9310		
	<b>Min:</b> 0	<b>Max:</b> 10	<b>Factory setting:</b> 7		
<b>Description:</b>	Sets the communication protocol for the field bus interface.				
<b>Value:</b>	0: No protocol 7: PROFINET 10: EtherNet/IP				
	<b>Note</b>				
	Changes only become effective after POWER ON. The parameter is not influenced by setting the factory setting.				
<b>r2032</b>	<b>Master control control word effective / PcCtrl STW eff</b>				
	<b>Access level:</b> 3	<b>Calculated:</b> -	<b>Data type:</b> Unsigned16		
	<b>Can be changed:</b> -	<b>Scaling:</b> -	<b>Dynamic index:</b> -		
	<b>Unit group:</b> -	<b>Unit selection:</b> -	<b>Function diagram:</b> -		
	<b>Min:</b> -	<b>Max:</b> -	<b>Factory setting:</b> -		
<b>Description:</b>	Displays the effective control word 1 (STW1) of the drive for the master control.				
<b>Bit field:</b>	<b>Bit</b>	<b>Signal name</b>	<b>1 signal</b>	<b>0 signal</b>	<b>FP</b>
	00	ON/OFF1	Yes	No	-
	01	OC / OFF2	Yes	No	-
	02	OC / OFF3	Yes	No	-
	03	Enable operation	Yes	No	-
	04	Enable ramp-function generator	Yes	No	-
	05	Start ramp-function generator	Yes	No	-
	06	Enable speed setpoint	Yes	No	-
	07	Acknowledge fault	Yes	No	-
	08	Jog bit 0	Yes	No	3030
	09	Jog bit 1	Yes	No	3030

7.3 Parameter list

10 Master control by PLC Yes No -

**NOTICE**  
The master control only influences control word 1 and speed setpoint 1. Other control word/setpoints can be transferred from another automation device.

**Note**  
OC: Operating condition

**p2037 PROFIdrive STW1.10 = 0 mode / PD STW1.10=0**

<b>Access level:</b> 3	<b>Calculated:</b> -	<b>Data type:</b> Integer16
<b>Can be changed:</b> T	<b>Scaling:</b> -	<b>Dynamic index:</b> -
<b>Unit group:</b> -	<b>Unit selection:</b> -	<b>Function diagram:</b> -
<b>Min:</b> 0	<b>Max:</b> 2	<b>Factory setting:</b> 0

**Description:** Sets the processing mode for PROFIdrive STW1.10 "master control by PLC".  
Generally, control world 1 is received with the first receive word (PZD1) (this is in conformance to the PROFIdrive profile). The behavior of STW1.10 = 0 corresponds to that of the PROFIdrive profile. For other applications that deviate from this, the behavior can be adapted using this particular parameter.

**Value:**  
0: Freeze setpoints and continue to process sign-of-life  
1: Freeze setpoints and sign-of-life  
2: Do not freeze setpoints

**Recommendation:** Do not change the setting p2037 = 0.

**Note**  
If the STW1 is not transferred according to the PROFIdrive with PZD1 (with bit 10 "master control by PLC"), then p2037 should be set to 2.

**p2038 PROFIdrive STW/ZSW interface mode / PD STW/ZSW IF mode**

<b>Access level:</b> 3	<b>Calculated:</b> -	<b>Data type:</b> Integer16
<b>Can be changed:</b> T	<b>Scaling:</b> -	<b>Dynamic index:</b> -
<b>Unit group:</b> -	<b>Unit selection:</b> -	<b>Function diagram:</b> -
<b>Min:</b> 0	<b>Max:</b> 2	<b>Factory setting:</b> 0

**Description:** Sets the interface mode of the PROFIdrive control words and status words.  
When selecting a telegram via p0922 (p2079), this parameter influences the device-specific assignment of the bits in the control and status words.

**Value:**  
0: SINAMICS  
2: VIK-NAMUR

**Dependency:** See also: p0922, p2079

**NOTICE**  
The parameter may be protected as a result of p0922 or p2079 and cannot be changed.

**Note**  
- For p0922 (p2079) = 1, 350 ... 999, p2038 is automatically set to 0.  
- For p0922 (p2079) = 20, p2038 is automatically set to 2.  
It is not then possible to change p2038.

<b>r2043.0...2</b>	<b>BO: PROFIdrive PZD state / PD PZD state</b>			
	<b>Access level:</b> 3	<b>Calculated:</b> -	<b>Data type:</b> Unsigned8	
	<b>Can be changed:</b> -	<b>Scaling:</b> -	<b>Dynamic index:</b> -	
	<b>Unit group:</b> -	<b>Unit selection:</b> -	<b>Function diagram:</b> 2410	
	<b>Min:</b>	<b>Max:</b>	<b>Factory setting:</b>	
	-	-	-	
<b>Description:</b>	Displays the PROFIdrive PZD state.			
<b>Bit field:</b>	<b>Bit</b>	<b>Signal name</b>	<b>1 signal</b>	<b>0 signal</b>
	00	Setpoint failure	Yes	No
	02	Fieldbus operation	Yes	No
<b>Dependency:</b>	See also: p2044			
	<b>Note</b>			
	When using the "setpoint failure" signal, the bus can be monitored and an application-specific response triggered when the setpoint fails.			

<b>p2044</b>	<b>PROFIdrive fault delay / PD fault delay</b>			
	<b>Access level:</b> 3	<b>Calculated:</b> -	<b>Data type:</b> FloatingPoint32	
	<b>Can be changed:</b> T, U	<b>Scaling:</b> -	<b>Dynamic index:</b> -	
	<b>Unit group:</b> -	<b>Unit selection:</b> -	<b>Function diagram:</b> 2410	
	<b>Min:</b>	<b>Max:</b>	<b>Factory setting:</b>	
	0 [s]	100 [s]	0 [s]	
<b>Description:</b>	Sets the delay time to initiate fault F01910 after a setpoint failure. The time until the fault is initiated can be used by the application. This means that it is possible to respond to the failure while the drive is still operational (e.g. emergency retraction).			
<b>Dependency:</b>	See also: r2043 See also: F01910			

<b>r2050[0...11]</b>	<b>CO: PROFIdrive PZD receive word / PZD recv word</b>			
	<b>Access level:</b> 3	<b>Calculated:</b> -	<b>Data type:</b> Integer16	
	<b>Can be changed:</b> -	<b>Scaling:</b> 4000H	<b>Dynamic index:</b> -	
	<b>Unit group:</b> -	<b>Unit selection:</b> -	<b>Function diagram:</b> 2440, 2468, 9360	
	<b>Min:</b>	<b>Max:</b>	<b>Factory setting:</b>	
	-	-	-	
<b>Description:</b>	Connector output to interconnect PZD (setpoints) with word format received from the fieldbus controller.			
<b>Index:</b>	[0] = PZD 1 [1] = PZD 2 [2] = PZD 3 [3] = PZD 4 [4] = PZD 5 [5] = PZD 6 [6] = PZD 7 [7] = PZD 8 [8] = PZD 9 [9] = PZD 10 [10] = PZD 11 [11] = PZD 12			

**NOTICE**

Where there is a multiple interconnection of a connector output, all the connector inputs must either have Integer or FloatingPoint data types. A BICO interconnection for a single PZD can only take place either on r2050 or r2060.

<b>p2051[0...16]</b>	<b>CI: PROFIdrive PZD send word / PZD send word</b>		
	<b>Access level:</b> 3	<b>Calculated:</b> -	<b>Data type:</b> Unsigned32 / Integer16
	<b>Can be changed:</b> T, U	<b>Scaling:</b> 4000H	<b>Dynamic index:</b> -
	<b>Unit group:</b> -	<b>Unit selection:</b> -	<b>Function diagram:</b> 2450, 2470, 9370
<b>Min:</b>	<b>Max:</b>	<b>Factory setting:</b>	
-	-	[0] 2089[0] [1] 63[0] [2...16] 0	

**Description:** Selects the PZD (actual values) with word format to be sent to the fieldbus controller.

**Index:**

[0] = PZD 1  
 [1] = PZD 2  
 [2] = PZD 3  
 [3] = PZD 4  
 [4] = PZD 5  
 [5] = PZD 6  
 [6] = PZD 7  
 [7] = PZD 8  
 [8] = PZD 9  
 [9] = PZD 10  
 [10] = PZD 11  
 [11] = PZD 12  
 [12] = PZD 13  
 [13] = PZD 14  
 [14] = PZD 15  
 [15] = PZD 16  
 [16] = PZD 17

**NOTICE**

The parameter may be protected as a result of p0922 or p2079 and cannot be changed.

<b>r2053[0...16]</b>	<b>PROFIdrive diagnostics send PZD word / Diag send word</b>		
	<b>Access level:</b> 3	<b>Calculated:</b> -	<b>Data type:</b> Unsigned16
	<b>Can be changed:</b> -	<b>Scaling:</b> -	<b>Dynamic index:</b> -
	<b>Unit group:</b> -	<b>Unit selection:</b> -	<b>Function diagram:</b> 2450, 2470, 9370
<b>Min:</b>	<b>Max:</b>	<b>Factory setting:</b>	
-	-	-	

**Description:** Displays the PZD (actual values) with word format sent to the fieldbus controller.

**Index:**

[0] = PZD 1  
 [1] = PZD 2  
 [2] = PZD 3  
 [3] = PZD 4  
 [4] = PZD 5  
 [5] = PZD 6  
 [6] = PZD 7  
 [7] = PZD 8  
 [8] = PZD 9  
 [9] = PZD 10  
 [10] = PZD 11  
 [11] = PZD 12  
 [12] = PZD 13  
 [13] = PZD 14  
 [14] = PZD 15  
 [15] = PZD 16  
 [16] = PZD 17

<b>Bit field:</b>	<b>Bit</b>	<b>Signal name</b>	<b>1 signal</b>	<b>0 signal</b>	<b>FP</b>
	00	Bit 0	ON	OFF	-
	01	Bit 1	ON	OFF	-
	02	Bit 2	ON	OFF	-
	03	Bit 3	ON	OFF	-
	04	Bit 4	ON	OFF	-
	05	Bit 5	ON	OFF	-
	06	Bit 6	ON	OFF	-
	07	Bit 7	ON	OFF	-
	08	Bit 8	ON	OFF	-
	09	Bit 9	ON	OFF	-
	10	Bit 10	ON	OFF	-
	11	Bit 11	ON	OFF	-
	12	Bit 12	ON	OFF	-
	13	Bit 13	ON	OFF	-
	14	Bit 14	ON	OFF	-
	15	Bit 15	ON	OFF	-

---

<b>r2060[0...10]</b>	<b>CO: PROFIdrive PZD receive double word / PZD recv DW</b>		
	<b>Access level:</b> 3	<b>Calculated:</b> -	<b>Data type:</b> Integer32
	<b>Can be changed:</b> -	<b>Scaling:</b> 4000H	<b>Dynamic index:</b> -
	<b>Unit group:</b> -	<b>Unit selection:</b> -	<b>Function diagram:</b> 2440, 2468
	<b>Min:</b>	<b>Max:</b>	<b>Factory setting:</b>
	-	-	-
<b>Description:</b>	Connector output to interconnect PZD (setpoints) with double word format received from the fieldbus controller.		

7.3 Parameter list

**Index:**  
[0] = PZD 1 + 2  
[1] = PZD 2 + 3  
[2] = PZD 3 + 4  
[3] = PZD 4 + 5  
[4] = PZD 5 + 6  
[5] = PZD 6 + 7  
[6] = PZD 7 + 8  
[7] = PZD 8 + 9  
[8] = PZD 9 + 10  
[9] = PZD 10 + 11  
[10] = PZD 11 + 12

**Dependency:** See also: r2050

<b>NOTICE</b> Where there is a multiple interconnection of a connector output, all the connector inputs must either have Integer or FloatingPoint data types. A BICO interconnection for a single PZD can only take place either on r2050 or r2060.
---

**p2061[0...15]**

**CI: PROFIdrive PZD send double word / PZD send DW**

<b>Access level:</b> 3	<b>Calculated:</b> -	<b>Data type:</b> Unsigned32 / Integer32
<b>Can be changed:</b> T, U	<b>Scaling:</b> 4000H	<b>Dynamic index:</b> -
<b>Unit group:</b> -	<b>Unit selection:</b> -	<b>Function diagram:</b> 2470
<b>Min:</b> -	<b>Max:</b> -	<b>Factory setting:</b> 0

**Description:** Selects the PZD (actual values) with double word format to be sent to the fieldbus controller.

**Index:**  
[0] = PZD 1 + 2  
[1] = PZD 2 + 3  
[2] = PZD 3 + 4  
[3] = PZD 4 + 5  
[4] = PZD 5 + 6  
[5] = PZD 6 + 7  
[6] = PZD 7 + 8  
[7] = PZD 8 + 9  
[8] = PZD 9 + 10  
[9] = PZD 10 + 11  
[10] = PZD 11 + 12  
[11] = PZD 12 + 13  
[12] = PZD 13 + 14  
[13] = PZD 14 + 15  
[14] = PZD 15 + 16  
[15] = PZD 16 + 17

**Dependency:** See also: p2051

<b>NOTICE</b> A BICO interconnection for a single PZD can only take place either on p2051 or p2061. The parameter may be protected as a result of p0922 or p2079 and cannot be changed.
---

<b>r2063[0...15]</b>	<b>PROFIdrive diagnostics PZD send double word / Diag send DW</b>	<b>Access level:</b> 3	<b>Calculated:</b> -	<b>Data type:</b> Unsigned32
		<b>Can be changed:</b> -	<b>Scaling:</b> -	<b>Dynamic index:</b> -
		<b>Unit group:</b> -	<b>Unit selection:</b> -	<b>Function diagram:</b> 2470
		<b>Min:</b>	<b>Max:</b>	<b>Factory setting:</b>
		-	-	-

**Description:** Displays the PZD (actual values) with double word format sent to the fieldbus controller.

**Index:**

- [0] = PZD 1 + 2
- [1] = PZD 2 + 3
- [2] = PZD 3 + 4
- [3] = PZD 4 + 5
- [4] = PZD 5 + 6
- [5] = PZD 6 + 7
- [6] = PZD 7 + 8
- [7] = PZD 8 + 9
- [8] = PZD 9 + 10
- [9] = PZD 10 + 11
- [10] = PZD 11 + 12
- [11] = PZD 12 + 13
- [12] = PZD 13 + 14
- [13] = PZD 14 + 15
- [14] = PZD 15 + 16
- [15] = PZD 16 + 17

<b>Bit field:</b>	<b>Bit</b>	<b>Signal name</b>	<b>1 signal</b>	<b>0 signal</b>	<b>FP</b>
	00	Bit 0	ON	OFF	-
	01	Bit 1	ON	OFF	-
	02	Bit 2	ON	OFF	-
	03	Bit 3	ON	OFF	-
	04	Bit 4	ON	OFF	-
	05	Bit 5	ON	OFF	-
	06	Bit 6	ON	OFF	-
	07	Bit 7	ON	OFF	-
	08	Bit 8	ON	OFF	-
	09	Bit 9	ON	OFF	-
	10	Bit 10	ON	OFF	-
	11	Bit 11	ON	OFF	-
	12	Bit 12	ON	OFF	-
	13	Bit 13	ON	OFF	-
	14	Bit 14	ON	OFF	-
	15	Bit 15	ON	OFF	-
	16	Bit 16	ON	OFF	-
	17	Bit 17	ON	OFF	-
	18	Bit 18	ON	OFF	-
	19	Bit 19	ON	OFF	-
	20	Bit 20	ON	OFF	-
	21	Bit 21	ON	OFF	-
	22	Bit 22	ON	OFF	-
	23	Bit 23	ON	OFF	-
	24	Bit 24	ON	OFF	-
	25	Bit 25	ON	OFF	-

7.3 Parameter list

26	Bit 26	ON	OFF	-
27	Bit 27	ON	OFF	-
28	Bit 28	ON	OFF	-
29	Bit 29	ON	OFF	-
30	Bit 30	ON	OFF	-
31	Bit 31	ON	OFF	-

<b>NOTICE</b>
A maximum of 4 indices of the "trace" function can be used.

---

**r2067[0...1]**      **PZD maximum interconnected / PZDmaxIntercon**

<b>Access level:</b> 3	<b>Calculated:</b> -	<b>Data type:</b> Unsigned16
<b>Can be changed:</b> -	<b>Scaling:</b> -	<b>Dynamic index:</b> -
<b>Unit group:</b> -	<b>Unit selection:</b> -	<b>Function diagram:</b> -
<b>Min:</b> -	<b>Max:</b> -	<b>Factory setting:</b> -

**Description:**      Display for the maximum interconnected PZD in the receive/send direction  
 Index 0: receive (r2050, r2060)  
 Index 1: send (p2051, p2061)

---

**p2079**      **PROFdrive PZD telegram selection extended / PZD telegr ext**

<b>Access level:</b> 3	<b>Calculated:</b> -	<b>Data type:</b> Integer16
<b>Can be changed:</b> T	<b>Scaling:</b> -	<b>Dynamic index:</b> -
<b>Unit group:</b> -	<b>Unit selection:</b> -	<b>Function diagram:</b> -
<b>Min:</b> 1	<b>Max:</b> 999	<b>Factory setting:</b> 1

**Description:**      Sets the send and receive telegram.  
 Contrary to p0922, a telegram can be selected using p2079 and subsequently expanded.

**Value:**

1:	Standard telegram 1, PZD-2/2
20:	Standard telegram 20, PZD-2/6
350:	SIEMENS telegram 350, PZD-4/4
352:	SIEMENS telegram 352, PZD-6/6
353:	SIEMENS telegram 353, PZD-2/2, PKW-4/4
354:	SIEMENS telegram 354, PZD-6/6, PKW-4/4
999:	Free telegram configuration with BICO

**Dependency:**      See also: p0922

---

**Note**

For p0922 < 999 the following applies:  
 p2079 has the same value and is inhibited. All of the interconnections and extensions contained in the telegram are inhibited.

For p0922 = 999 the following applies:  
 p2079 can be freely set. If p2079 is also set to 999, then all of the interconnections can be set.

For p0922 = 999 and p2079 < 999 the following applies:  
 The interconnections contained in the telegram are inhibited. However, the telegram can be extended.

---



<b>p2080[0...15]</b>	<b>BI: Binector-connector converter status word 1 / Bin/con ZSW1</b>		
	<b>Access level:</b> 3	<b>Calculated:</b> -	<b>Data type:</b> Unsigned32 / Binary
	<b>Can be changed:</b> T, U	<b>Scaling:</b> -	<b>Dynamic index:</b> -
	<b>Unit group:</b> -	<b>Unit selection:</b> -	<b>Function diagram:</b> 2472
	<b>Min:</b> -	<b>Max:</b> -	<b>Factory setting:</b>
			[0] 899.0
			[1] 899.1
			[2] 899.2
			[3] 2139.3
			[4] 899.4
			[5] 899.5
			[6] 899.6
			[7] 2139.7
			[8] 2197.7
			[9] 899.9
			[10] 2199.1
			[11] 1407.7
			[12] 0
			[13] 2135.14
			[14] 2197.3
			[15] 2135.15

**Description:** Selects bits to be sent to the PROFIdrive controller.  
The individual bits are combined to form status word 1.

**Index:**

- [0] = Bit 0
- [1] = Bit 1
- [2] = Bit 2
- [3] = Bit 3
- [4] = Bit 4
- [5] = Bit 5
- [6] = Bit 6
- [7] = Bit 7
- [8] = Bit 8
- [9] = Bit 9
- [10] = Bit 10
- [11] = Bit 11
- [12] = Bit 12
- [13] = Bit 13
- [14] = Bit 14
- [15] = Bit 15

**Dependency:** See also: p2088, r2089

<b>NOTICE</b>
---------------

The parameter may be protected as a result of p0922 or p2079 and cannot be changed.
---

<b>p2081[0...15]</b>	<b>BI: Binector-connector converter status word 2 / Bin/con ZSW2</b>		
	<b>Access level:</b> 3	<b>Calculated:</b> -	<b>Data type:</b> Unsigned32 / Binary
	<b>Can be changed:</b> T, U	<b>Scaling:</b> -	<b>Dynamic index:</b> -
	<b>Unit group:</b> -	<b>Unit selection:</b> -	<b>Function diagram:</b> 2472
	<b>Min:</b> -	<b>Max:</b> -	<b>Factory setting:</b>
			0

7.3 Parameter list

**Description:** Selects bits to be sent to the PROFIdrive controller.  
The individual bits are combined to form status word 2.

**Index:** [0] = Bit 0  
[1] = Bit 1  
[2] = Bit 2  
[3] = Bit 3  
[4] = Bit 4  
[5] = Bit 5  
[6] = Bit 6  
[7] = Bit 7  
[8] = Bit 8  
[9] = Bit 9  
[10] = Bit 10  
[11] = Bit 11  
[12] = Bit 12  
[13] = Bit 13  
[14] = Bit 14  
[15] = Bit 15

**Dependency:** See also: p2088, r2089

**NOTICE**  
The parameter may be protected as a result of p0922 or p2079 and cannot be changed.

**p2082[0...15]**      **BI: Binector-connector converter status word 3 / Bin/con ZSW3**

<b>Access level:</b> 3	<b>Calculated:</b> -	<b>Data type:</b> Unsigned32 / Binary
<b>Can be changed:</b> T, U	<b>Scaling:</b> -	<b>Dynamic index:</b> -
<b>Unit group:</b> -	<b>Unit selection:</b> -	<b>Function diagram:</b> 2472
<b>Min:</b> -	<b>Max:</b> -	<b>Factory setting:</b> 0

**Description:** Selects bits to be sent to the PROFIdrive controller.  
The individual bits are combined to form free status word 3.

**Index:** [0] = Bit 0  
[1] = Bit 1  
[2] = Bit 2  
[3] = Bit 3  
[4] = Bit 4  
[5] = Bit 5  
[6] = Bit 6  
[7] = Bit 7  
[8] = Bit 8  
[9] = Bit 9  
[10] = Bit 10  
[11] = Bit 11  
[12] = Bit 12  
[13] = Bit 13  
[14] = Bit 14  
[15] = Bit 15

**Dependency:** See also: p2088, r2089

**NOTICE**  
The parameter may be protected as a result of p0922 or p2079 and cannot be changed.

---

<b>p2083[0...15]</b>	<b>BI: Binector-connector converter status word 4 / Bin/con ZSW4</b>		
	<b>Access level:</b> 3	<b>Calculated:</b> -	<b>Data type:</b> Unsigned32 / Binary
	<b>Can be changed:</b> T, U	<b>Scaling:</b> -	<b>Dynamic index:</b> -
	<b>Unit group:</b> -	<b>Unit selection:</b> -	<b>Function diagram:</b> 2472
	<b>Min:</b>	<b>Max:</b>	<b>Factory setting:</b>
	-	-	0

**Description:** Selects bits to be sent to the PROFIdrive controller.  
The individual bits are combined to form free status word 4.

**Index:**

- [0] = Bit 0
- [1] = Bit 1
- [2] = Bit 2
- [3] = Bit 3
- [4] = Bit 4
- [5] = Bit 5
- [6] = Bit 6
- [7] = Bit 7
- [8] = Bit 8
- [9] = Bit 9
- [10] = Bit 10
- [11] = Bit 11
- [12] = Bit 12
- [13] = Bit 13
- [14] = Bit 14
- [15] = Bit 15

**Dependency:** See also: p2088, r2089

---

<b>p2084[0...15]</b>	<b>BI: Binector-connector converter status word 5 / Bin/con ZSW5</b>		
	<b>Access level:</b> 3	<b>Calculated:</b> -	<b>Data type:</b> Unsigned32 / Binary
	<b>Can be changed:</b> T, U	<b>Scaling:</b> -	<b>Dynamic index:</b> -
	<b>Unit group:</b> -	<b>Unit selection:</b> -	<b>Function diagram:</b> 2472
	<b>Min:</b>	<b>Max:</b>	<b>Factory setting:</b>
	-	-	0

**Description:** Selects bits to be sent to the PROFIdrive controller.  
The individual bits are combined to form free status word 5.

**Index:**

- [0] = Bit 0
- [1] = Bit 1
- [2] = Bit 2
- [3] = Bit 3
- [4] = Bit 4
- [5] = Bit 5
- [6] = Bit 6
- [7] = Bit 7
- [8] = Bit 8
- [9] = Bit 9
- [10] = Bit 10
- [11] = Bit 11
- [12] = Bit 12
- [13] = Bit 13
- [14] = Bit 14
- [15] = Bit 15

**Dependency:** See also: p2088, r2089

7.3 Parameter list

**p2088[0..4]**      **Invert binector-connector converter status word / Bin/con ZSW inv**

<b>Access level:</b> 3	<b>Calculated:</b> -	<b>Data type:</b> Unsigned16
<b>Can be changed:</b> T, U	<b>Scaling:</b> -	<b>Dynamic index:</b> -
<b>Unit group:</b> -	<b>Unit selection:</b> -	<b>Function diagram:</b> 2472
<b>Min:</b>	<b>Max:</b>	<b>Factory setting:</b>
-	-	[0] 1010 1000 0000 0000 bin
		[1...4] 0000 0000 0000 0000 bin

**Description:** Setting to invert the individual binector inputs of the binector-connector converter.

**Index:**  
 [0] = Status word 1  
 [1] = Status word 2  
 [2] = Free status word 3  
 [3] = Free status word 4  
 [4] = Free status word 5

<b>Bit field:</b>	<b>Bit</b>	<b>Signal name</b>	<b>1 signal</b>	<b>0 signal</b>	<b>FP</b>
	00	Bit 0	Inverted	Not inverted	-
	01	Bit 1	Inverted	Not inverted	-
	02	Bit 2	Inverted	Not inverted	-
	03	Bit 3	Inverted	Not inverted	-
	04	Bit 4	Inverted	Not inverted	-
	05	Bit 5	Inverted	Not inverted	-
	06	Bit 6	Inverted	Not inverted	-
	07	Bit 7	Inverted	Not inverted	-
	08	Bit 8	Inverted	Not inverted	-
	09	Bit 9	Inverted	Not inverted	-
	10	Bit 10	Inverted	Not inverted	-
	11	Bit 11	Inverted	Not inverted	-
	12	Bit 12	Inverted	Not inverted	-
	13	Bit 13	Inverted	Not inverted	-
	14	Bit 14	Inverted	Not inverted	-
	15	Bit 15	Inverted	Not inverted	-

**Dependency:** See also: p2080, p2081, p2082, p2083, r2089

**r2089[0...4]**      **CO: Send binector-connector converter status word / Bin/con ZSW send**

<b>Access level:</b> 3	<b>Calculated:</b> -	<b>Data type:</b> Unsigned16
<b>Can be changed:</b> -	<b>Scaling:</b> -	<b>Dynamic index:</b> -
<b>Unit group:</b> -	<b>Unit selection:</b> -	<b>Function diagram:</b> 2472
<b>Min:</b>	<b>Max:</b>	<b>Factory setting:</b>
-	-	-

**Description:** Connector output to interconnect the status words to a PZD send word.

**Index:**  
 [0] = Status word 1  
 [1] = Status word 2  
 [2] = Free status word 3  
 [3] = Free status word 4  
 [4] = Free status word 5

<b>Bit field:</b>	<b>Bit</b>	<b>Signal name</b>	<b>1 signal</b>	<b>0 signal</b>	<b>FP</b>
	00	Bit 0	ON	OFF	-
	01	Bit 1	ON	OFF	-
	02	Bit 2	ON	OFF	-
	03	Bit 3	ON	OFF	-

04	Bit 4	ON	OFF	-
05	Bit 5	ON	OFF	-
06	Bit 6	ON	OFF	-
07	Bit 7	ON	OFF	-
08	Bit 8	ON	OFF	-
09	Bit 9	ON	OFF	-
10	Bit 10	ON	OFF	-
11	Bit 11	ON	OFF	-
12	Bit 12	ON	OFF	-
13	Bit 13	ON	OFF	-
14	Bit 14	ON	OFF	-
15	Bit 15	ON	OFF	-

**Dependency:** See also: p2051, p2080, p2081, p2082, p2083

**Note**

r2089 together with p2080 to p2084 forms five binector-connector converters.

**r2090.0...15 BO: PROFIdrive PZD1 receive bit-serial / PZD1 recv bitw**

**Access level:** 3

**Calculated:** -

**Data type:** Unsigned16

**Can be changed:** -

**Scaling:** -

**Dynamic index:** -

**Unit group:** -

**Unit selection:** -

**Function diagram:** 2468, 9204, 9206, 9360

**Min:**

**Max:**

**Factory setting:**

-

-

-

**Description:**

Binector output for bit-serial interconnection of PZD1 (normally control word 1) received from the PROFIdrive controller.

**Bit field:**

Bit	Signal name	1 signal	0 signal	FP
00	Bit 0	ON	OFF	-
01	Bit 1	ON	OFF	-
02	Bit 2	ON	OFF	-
03	Bit 3	ON	OFF	-
04	Bit 4	ON	OFF	-
05	Bit 5	ON	OFF	-
06	Bit 6	ON	OFF	-
07	Bit 7	ON	OFF	-
08	Bit 8	ON	OFF	-
09	Bit 9	ON	OFF	-
10	Bit 10	ON	OFF	-
11	Bit 11	ON	OFF	-
12	Bit 12	ON	OFF	-
13	Bit 13	ON	OFF	-
14	Bit 14	ON	OFF	-
15	Bit 15	ON	OFF	-

<b>r2091.0...15</b>	<b>BO: PROFIdrive PZD2 receive bit-serial / PZD2 recv bitw</b>				
<b>Access level:</b> 3	<b>Calculated:</b> -	<b>Data type:</b> Unsigned16			
<b>Can be changed:</b> -	<b>Scaling:</b> -	<b>Dynamic index:</b> -			
<b>Unit group:</b> -	<b>Unit selection:</b> -	<b>Function diagram:</b> 2468, 9204, 9206			
<b>Min:</b> -	<b>Max:</b> -	<b>Factory setting:</b> -			
<b>Description:</b>	Binector output for bit-serial interconnection of PZD2 received from the PROFIdrive controller.				
<b>Bit field:</b>	<b>Bit</b>	<b>Signal name</b>	<b>1 signal</b>	<b>0 signal</b>	<b>FP</b>
	00	Bit 0	ON	OFF	-
	01	Bit 1	ON	OFF	-
	02	Bit 2	ON	OFF	-
	03	Bit 3	ON	OFF	-
	04	Bit 4	ON	OFF	-
	05	Bit 5	ON	OFF	-
	06	Bit 6	ON	OFF	-
	07	Bit 7	ON	OFF	-
	08	Bit 8	ON	OFF	-
	09	Bit 9	ON	OFF	-
	10	Bit 10	ON	OFF	-
	11	Bit 11	ON	OFF	-
	12	Bit 12	ON	OFF	-
	13	Bit 13	ON	OFF	-
	14	Bit 14	ON	OFF	-
	15	Bit 15	ON	OFF	-

<b>r2092.0...15</b>	<b>BO: PROFIdrive PZD3 receive bit-serial / PZD3 recv bitw</b>				
<b>Access level:</b> 3	<b>Calculated:</b> -	<b>Data type:</b> Unsigned16			
<b>Can be changed:</b> -	<b>Scaling:</b> -	<b>Dynamic index:</b> -			
<b>Unit group:</b> -	<b>Unit selection:</b> -	<b>Function diagram:</b> 2468, 9204, 9206			
<b>Min:</b> -	<b>Max:</b> -	<b>Factory setting:</b> -			
<b>Description:</b>	Binector output for bit-serial interconnection of PZD3 received from the PROFIdrive controller.				
<b>Bit field:</b>	<b>Bit</b>	<b>Signal name</b>	<b>1 signal</b>	<b>0 signal</b>	<b>FP</b>
	00	Bit 0	ON	OFF	-
	01	Bit 1	ON	OFF	-
	02	Bit 2	ON	OFF	-
	03	Bit 3	ON	OFF	-
	04	Bit 4	ON	OFF	-
	05	Bit 5	ON	OFF	-
	06	Bit 6	ON	OFF	-
	07	Bit 7	ON	OFF	-
	08	Bit 8	ON	OFF	-
	09	Bit 9	ON	OFF	-
	10	Bit 10	ON	OFF	-
	11	Bit 11	ON	OFF	-
	12	Bit 12	ON	OFF	-
	13	Bit 13	ON	OFF	-

14	Bit 14	ON	OFF	-
15	Bit 15	ON	OFF	-

---

<b>r2093.0...15</b>	<b>BO: PROFIdrive PZD4 receive bit-serial / PZD4 rcv bitw</b>				
	<b>Access level:</b> 3	<b>Calculated:</b> -	<b>Data type:</b> Unsigned16		
	<b>Can be changed:</b> -	<b>Scaling:</b> -	<b>Dynamic index:</b> -		
	<b>Unit group:</b> -	<b>Unit selection:</b> -	<b>Function diagram:</b> 2468, 9204, 9206		
	<b>Min:</b> -	<b>Max:</b> -	<b>Factory setting:</b> -		
<b>Description:</b>	Binector output for bit-serial interconnection of PZD4 (normally control word 2) received from the PROFIdrive controller.				
<b>Bit field:</b>	<b>Bit</b>	<b>Signal name</b>	<b>1 signal</b>	<b>0 signal</b>	<b>FP</b>
	00	Bit 0	ON	OFF	-
	01	Bit 1	ON	OFF	-
	02	Bit 2	ON	OFF	-
	03	Bit 3	ON	OFF	-
	04	Bit 4	ON	OFF	-
	05	Bit 5	ON	OFF	-
	06	Bit 6	ON	OFF	-
	07	Bit 7	ON	OFF	-
	08	Bit 8	ON	OFF	-
	09	Bit 9	ON	OFF	-
	10	Bit 10	ON	OFF	-
	11	Bit 11	ON	OFF	-
	12	Bit 12	ON	OFF	-
	13	Bit 13	ON	OFF	-
	14	Bit 14	ON	OFF	-
	15	Bit 15	ON	OFF	-

---

<b>r2094.0...15</b>	<b>BO: Connector-binector converter binector output / Con/bin outp</b>				
	<b>Access level:</b> 3	<b>Calculated:</b> -	<b>Data type:</b> Unsigned16		
	<b>Can be changed:</b> -	<b>Scaling:</b> -	<b>Dynamic index:</b> -		
	<b>Unit group:</b> -	<b>Unit selection:</b> -	<b>Function diagram:</b> 2468, 9360		
	<b>Min:</b> -	<b>Max:</b> -	<b>Factory setting:</b> -		
<b>Description:</b>	Binector output for bit-serial onward interconnection of a PZD word received from the PROFIdrive controller. The PZD is selected via p2099[0].				
<b>Bit field:</b>	<b>Bit</b>	<b>Signal name</b>	<b>1 signal</b>	<b>0 signal</b>	<b>FP</b>
	00	Bit 0	ON	OFF	-
	01	Bit 1	ON	OFF	-
	02	Bit 2	ON	OFF	-
	03	Bit 3	ON	OFF	-
	04	Bit 4	ON	OFF	-
	05	Bit 5	ON	OFF	-
	06	Bit 6	ON	OFF	-
	07	Bit 7	ON	OFF	-
	08	Bit 8	ON	OFF	-
	09	Bit 9	ON	OFF	-

7.3 Parameter list

10	Bit 10	ON	OFF	-
11	Bit 11	ON	OFF	-
12	Bit 12	ON	OFF	-
13	Bit 13	ON	OFF	-
14	Bit 14	ON	OFF	-
15	Bit 15	ON	OFF	-

Dependency: See also: p2099

**r2095.0...15**

**BO: Connector-binector converter binector output / Con/bin outp**

<b>Access level:</b> 3	<b>Calculated:</b> -	<b>Data type:</b> Unsigned16
<b>Can be changed:</b> -	<b>Scaling:</b> -	<b>Dynamic index:</b> -
<b>Unit group:</b> -	<b>Unit selection:</b> -	<b>Function diagram:</b> 2468, 9360
<b>Min:</b> -	<b>Max:</b> -	<b>Factory setting:</b> -

**Description:** Binector output for bit-serial interconnection of a PZD word received from the PROFIdrive controller. The PZD is selected via p2099[1].

Bit field:	Bit	Signal name	1 signal	0 signal	FP
	00	Bit 0	ON	OFF	-
	01	Bit 1	ON	OFF	-
	02	Bit 2	ON	OFF	-
	03	Bit 3	ON	OFF	-
	04	Bit 4	ON	OFF	-
	05	Bit 5	ON	OFF	-
	06	Bit 6	ON	OFF	-
	07	Bit 7	ON	OFF	-
	08	Bit 8	ON	OFF	-
	09	Bit 9	ON	OFF	-
	10	Bit 10	ON	OFF	-
	11	Bit 11	ON	OFF	-
	12	Bit 12	ON	OFF	-
	13	Bit 13	ON	OFF	-
	14	Bit 14	ON	OFF	-
	15	Bit 15	ON	OFF	-

Dependency: See also: p2099

**p2098[0...1]**

**Inverter connector-binector converter binector output / Con/bin outp inv**

<b>Access level:</b> 3	<b>Calculated:</b> -	<b>Data type:</b> Unsigned16
<b>Can be changed:</b> T, U	<b>Scaling:</b> -	<b>Dynamic index:</b> -
<b>Unit group:</b> -	<b>Unit selection:</b> -	<b>Function diagram:</b> 2468, 9360
<b>Min:</b> -	<b>Max:</b> -	<b>Factory setting:</b> 0000 0000 0000 0000 bin

**Description:** Setting to invert the individual binector outputs of the connector-binector converter. Using p2098[0], the signals of connector input p2099[0] are influenced. Using p2098[1], the signals of connector input p2099[1] are influenced.

Bit field:	Bit	Signal name	1 signal	0 signal	FP
	00	Bit 0	Inverted	Not inverted	-
	01	Bit 1	Inverted	Not inverted	-
	02	Bit 2	Inverted	Not inverted	-
	03	Bit 3	Inverted	Not inverted	-



04	Bit 4	Inverted	Not inverted	-
05	Bit 5	Inverted	Not inverted	-
06	Bit 6	Inverted	Not inverted	-
07	Bit 7	Inverted	Not inverted	-
08	Bit 8	Inverted	Not inverted	-
09	Bit 9	Inverted	Not inverted	-
10	Bit 10	Inverted	Not inverted	-
11	Bit 11	Inverted	Not inverted	-
12	Bit 12	Inverted	Not inverted	-
13	Bit 13	Inverted	Not inverted	-
14	Bit 14	Inverted	Not inverted	-
15	Bit 15	Inverted	Not inverted	-

**Dependency:** See also: r2094, r2095, p2099

---

### p2099[0...1] CI: Connector-binector converter signal source / Con/bin S\_src

<b>Access level:</b> 3	<b>Calculated:</b> -	<b>Data type:</b> Unsigned32 / Integer16
<b>Can be changed:</b> T, U	<b>Scaling:</b> -	<b>Dynamic index:</b> -
<b>Unit group:</b> -	<b>Unit selection:</b> -	<b>Function diagram:</b> 2468, 9360
<b>Min:</b> -	<b>Max:</b> -	<b>Factory setting:</b> 0

**Description:** Sets the signal source for the connector-binector converter.  
A PZD receive word can be selected as signal source. The signals are available to be serially passed-on (interconnection).

**Dependency:** See also: r2094, r2095

---

#### Note

From the signal source set via the connector input, the corresponding lower 16 bits are converted. p2099[0...1] together with r2094.0...15 and r2095.0...15 forms two connector-binector converters:  
Connector input p2099[0] to binector output in r2094.0...15  
Connector input p2099[1] to binector output in r2095.0...15

---

### p2100[0...19] Change fault response fault number / Chng resp F\_no

<b>Access level:</b> 3	<b>Calculated:</b> -	<b>Data type:</b> Unsigned16
<b>Can be changed:</b> T, U	<b>Scaling:</b> -	<b>Dynamic index:</b> -
<b>Unit group:</b> -	<b>Unit selection:</b> -	<b>Function diagram:</b> 8050, 8075
<b>Min:</b> 0	<b>Max:</b> 65535	<b>Factory setting:</b> 0

**Description:** Selects the faults for which the fault response should be changed

**Dependency:** The fault is selected and the required response is set under the same index.

See also: p2101

---

#### Note

Re-parameterization is also possible if a fault is present. The change only becomes effective after the fault has been resolved.

<b>p2101[0...19]</b>	<b>Change fault response response / Chng resp resp</b>		
	<b>Access level:</b> 3	<b>Calculated:</b> -	<b>Data type:</b> Integer16
	<b>Can be changed:</b> T, U	<b>Scaling:</b> -	<b>Dynamic index:</b> -
	<b>Unit group:</b> -	<b>Unit selection:</b> -	<b>Function diagram:</b> 8050, 8075
	<b>Min:</b> 0	<b>Max:</b> 6	<b>Factory setting:</b> 0
<b>Description:</b>	Sets the fault response for the selected fault.		
<b>Value:</b>	0: NONE 1: OFF1 2: OFF2 3: OFF3 5: STOP2 6: Internal armature short-circuit / DC braking		
<b>Dependency:</b>	The fault is selected and the required response is set under the same index. See also: p2100		

**NOTICE**

For the following cases, it is not possible to re-parameterize the fault response to a fault:

- fault number does not exist (exception value = 0).
- Message type is not "fault" (F).
- fault response is not permissible for the set fault number.

**Note**

Re-parameterization is also possible if a fault is present. The change only becomes effective after the fault has been resolved.

The fault response can only be changed for faults with the appropriate identification.

Example:  
 F12345 and fault response = NONE (OFF1, OFF2)  
 --> The fault response NONE can be changed to OFF1 or OFF2.

For value = 1 (OFF1):  
 Braking along the ramp-function generator down ramp followed by a pulse inhibit.

For value = 2 (OFF2):  
 Internal/external pulse inhibit.

For value = 3 (OFF3):  
 Braking along the OFF3 down ramp followed by a pulse inhibit.

For value = 5 (STOP2):  
 n\_set = 0

For value = 6 (armature short-circuit, internal/DC braking):  
 This value can only be set for all drive data sets when p1231 = 4.

a) DC braking is not possible for synchronous motors.  
 b) DC braking is possible for induction motors.

<b>p2103[0...n]</b>	<b>BI: 1st acknowledge faults / 1st acknowledge</b>		
	<b>Access level:</b> 3	<b>Calculated:</b> -	<b>Data type:</b> Unsigned32 / Binary
	<b>Can be changed:</b> T, U	<b>Scaling:</b> -	<b>Dynamic index:</b> CDS, p0170
	<b>Unit group:</b> -	<b>Unit selection:</b> -	<b>Function diagram:</b> 2441, 2442, 2443, 2447, 2475, 2546, 9220, 9677, 9678
	<b>Min:</b> -	<b>Max:</b> -	<b>Factory setting:</b> [0] 2090.7 [1] 722.2 [2] 2090.7 [3] 2090.7
<b>Description:</b>	Sets the first signal source to acknowledge faults.		

<b>NOTICE</b>
The parameter may be protected as a result of p0922 or p2079 and cannot be changed.

**Note**

A fault acknowledgment is triggered with a 0/1 signal.

<b>p2104[0...n]</b>	<b>BI: 2nd acknowledge faults / 2nd acknowledge</b>		
	<b>Access level:</b> 3	<b>Calculated:</b> -	<b>Data type:</b> Unsigned32 / Binary
	<b>Can be changed:</b> T, U	<b>Scaling:</b> -	<b>Dynamic index:</b> CDS, p0170
	<b>Unit group:</b> -	<b>Unit selection:</b> -	<b>Function diagram:</b> 2546, 8060
	<b>Min:</b>	<b>Max:</b>	<b>Factory setting:</b>
	-	-	[0] 722.5
			[1] 722.5
			[2] 0
			[3] 0

**Description:** Sets the second signal source to acknowledge faults.

**Note**

A fault acknowledgment is triggered with a 0/1 signal.

<b>p2105[0...n]</b>	<b>BI: 3rd acknowledge faults / 3rd acknowledge</b>		
	<b>Access level:</b> 3	<b>Calculated:</b> -	<b>Data type:</b> Unsigned32 / Binary
	<b>Can be changed:</b> T, U	<b>Scaling:</b> -	<b>Dynamic index:</b> CDS, p0170
	<b>Unit group:</b> -	<b>Unit selection:</b> -	<b>Function diagram:</b> 2546, 8060
	<b>Min:</b>	<b>Max:</b>	<b>Factory setting:</b>
	-	-	0

**Description:** Sets the third signal source to acknowledge faults.

**Note**

A fault acknowledgment is triggered with a 0/1 signal.

<b>p2106[0...n]</b>	<b>BI: External fault 1 / External fault 1</b>		
	<b>Access level:</b> 3	<b>Calculated:</b> -	<b>Data type:</b> Unsigned32 / Binary
	<b>Can be changed:</b> T, U	<b>Scaling:</b> -	<b>Dynamic index:</b> CDS, p0170
	<b>Unit group:</b> -	<b>Unit selection:</b> -	<b>Function diagram:</b> 2546
	<b>Min:</b>	<b>Max:</b>	<b>Factory setting:</b>
	-	-	1

**Description:** Sets the signal source for external fault 1.

**Dependency:** See also: F07860

**Note**

An external fault is triggered with a 1/0 signal.

<b>p2107[0...n]</b>	<b>BI: External fault 2 / External fault 2</b>		
	<b>Access level:</b> 3	<b>Calculated:</b> -	<b>Data type:</b> Unsigned32 / Binary
	<b>Can be changed:</b> T, U	<b>Scaling:</b> -	<b>Dynamic index:</b> CDS, p0170
	<b>Unit group:</b> -	<b>Unit selection:</b> -	<b>Function diagram:</b> 2546
	<b>Min:</b>	<b>Max:</b>	<b>Factory setting:</b>
	-	-	1

**Description:** Sets the signal source for external fault 2.

**Dependency:** See also: F07861

7.3 Parameter list

**Note**

An external fault is triggered with a 1/0 signal.

**p2108[0...n]**

**BI: External fault 3 / External fault 3**

**Access level:** 3

**Calculated:** -

**Data type:** Unsigned32 / Binary

**Can be changed:** T, U

**Scaling:** -

**Dynamic index:** CDS, p0170

**Unit group:** -

**Unit selection:** -

**Function diagram:** 2546

**Min:**

**Max:**

**Factory setting:**

-

-

1

**Description:**

Sets the signal source for external fault 3.

External fault 3 is initiated by the following AND logic operation:

- BI: p2108 negated

- BI: p3111

- BI: p3112 negated

**Dependency:**

See also: p3110, p3111, p3112

See also: F07862

**Note**

An external fault is triggered with a 1/0 signal.

**p2108[0...n]**

**BI: External fault 3 / External fault 3**

CUG120X\_PN  
(PM330)

**Access level:** 3

**Calculated:** -

**Data type:** Unsigned32 / Binary

**Can be changed:** T, U

**Scaling:** -

**Dynamic index:** CDS, p0170

**Unit group:** -

**Unit selection:** -

**Function diagram:** 2546

**Min:**

**Max:**

**Factory setting:**

-

-

4022.1

**Description:**

Sets the signal source for external fault 3.

External fault 3 is initiated by the following AND logic operation:

- BI: p2108 negated

- BI: p3111

- BI: p3112 negated

**Dependency:**

See also: p3110, p3111, p3112

See also: F07862

**Note**

An external fault is triggered with a 1/0 signal.

**r2109[0...63]**

**Fault time removed in milliseconds / t\_fit resolved ms**

**Access level:** 3

**Calculated:** -

**Data type:** Unsigned32

**Can be changed:** -

**Scaling:** -

**Dynamic index:** -

**Unit group:** -

**Unit selection:** -

**Function diagram:** 8050, 8060

**Min:**

**Max:**

**Factory setting:**

- [ms]

- [ms]

- [ms]

**Description:**

Displays the system runtime in milliseconds when the fault was removed.

**Dependency:**

See also: r0945, r0947, r0948, r0949, r2130, r2133, r2136, p8400

**NOTICE**

The time comprises r2136 (days) and r2109 (milliseconds).

**Note**

The buffer parameters are cyclically updated in the background (refer to status signal in r2139).

The structure of the fault buffer and the assignment of the indices is shown in r0945.

<b>r2110[0...63]</b>	<b>Alarm number / Alarm number</b> Access level: 2 Can be changed: - Unit group: - Min: -	Calculated: - Scaling: - Unit selection: - Max: -	Data type: Unsigned16 Dynamic index: - Function diagram: 8065 Factory setting: -
<b>Description:</b>	This parameter is identical to r2122.		
<b>p2111</b>	<b>Alarm counter / Alarm counter</b> Access level: 3 Can be changed: T, U Unit group: - Min: 0	Calculated: - Scaling: - Unit selection: - Max: 65535	Data type: Unsigned16 Dynamic index: - Function diagram: 8050, 8065 Factory setting: 0
<b>Description:</b>	Number of alarms that have occurred after the last reset.		
<b>Dependency:</b>	When p2111 is set to 0, the following is initiated: - all of the alarms of the alarm buffer that have gone [0...7] are transferred into the alarm history [8...63]. - the alarm buffer [0...7] is deleted. See also: r2110, r2122, r2123, r2124, r2125		
	<b>Note</b> The parameter is reset to 0 at POWER ON.		
<b>p2112[0...n]</b>	<b>BI: External alarm 1 / External alarm 1</b> Access level: 3 Can be changed: T, U Unit group: - Min: -	Calculated: - Scaling: - Unit selection: - Max: -	Data type: Unsigned32 / Binary Dynamic index: CDS, p0170 Function diagram: 2546 Factory setting: 1
<b>Description:</b>	Sets the signal source for external alarm 1.		
<b>Dependency:</b>	See also: A07850		
	<b>Note</b> An external alarm is triggered with a 1/0 signal.		
<b>r2114[0...1]</b>	<b>System runtime total / Sys runtime tot</b> Access level: 3 Can be changed: - Unit group: - Min: -	Calculated: - Scaling: - Unit selection: - Max: -	Data type: Unsigned32 Dynamic index: - Function diagram: - Factory setting: -
<b>Description:</b>	Displays the total system runtime for the drive unit. The time comprises r2114[0] (milliseconds) and r2114[1] (days). After r2114[0] has reached a value of 86.400.000 ms (24 hours) this value is reset and r2114[1] is incremented.		
<b>Index:</b>	[0] = Milliseconds [1] = Days		
<b>Dependency:</b>	See also: r0948, r2109, r2123, r2125, r2130, r2136, r2145, r2146		
	<b>Note</b> When the electronic power supply is switched out, the counter values are saved. After the drive unit is switched on, the counter continues to run with the last value that was saved.		

<b>p2116[0...n]</b>	<b>BI: External alarm 2 / External alarm 2</b>		
	<b>Access level:</b> 3	<b>Calculated:</b> -	<b>Data type:</b> Unsigned32 / Binary
	<b>Can be changed:</b> T, U	<b>Scaling:</b> -	<b>Dynamic index:</b> CDS, p0170
	<b>Unit group:</b> -	<b>Unit selection:</b> -	<b>Function diagram:</b> 2546
	<b>Min:</b>	<b>Max:</b>	<b>Factory setting:</b>
	-	-	1
<b>Description:</b>	Sets the signal source for external alarm 2.		
<b>Dependency:</b>	See also: A07851		
	<b>Note</b>		
	An external alarm is triggered with a 1/0 signal.		
<b>p2117[0...n]</b>	<b>BI: External alarm 3 / External alarm 3</b>		
	<b>Access level:</b> 3	<b>Calculated:</b> -	<b>Data type:</b> Unsigned32 / Binary
	<b>Can be changed:</b> T, U	<b>Scaling:</b> -	<b>Dynamic index:</b> CDS, p0170
	<b>Unit group:</b> -	<b>Unit selection:</b> -	<b>Function diagram:</b> 2546
	<b>Min:</b>	<b>Max:</b>	<b>Factory setting:</b>
	-	-	1
<b>Description:</b>	Sets the signal source for external alarm 3.		
<b>Dependency:</b>	See also: A07852		
	<b>Note</b>		
	An external alarm is triggered with a 1/0 signal.		
<b>p2117[0...n]</b> CUG120X_PN (PM330)	<b>BI: External alarm 3 / External alarm 3</b>		
	<b>Access level:</b> 3	<b>Calculated:</b> -	<b>Data type:</b> Unsigned32 / Binary
	<b>Can be changed:</b> T, U	<b>Scaling:</b> -	<b>Dynamic index:</b> CDS, p0170
	<b>Unit group:</b> -	<b>Unit selection:</b> -	<b>Function diagram:</b> 2546
	<b>Min:</b>	<b>Max:</b>	<b>Factory setting:</b>
	-	-	4022.0
<b>Description:</b>	Sets the signal source for external alarm 3.		
<b>Dependency:</b>	See also: A07852		
	<b>Note</b>		
	An external alarm is triggered with a 1/0 signal.		
<b>p2118[0...19]</b>	<b>Change message type message number / Chng type msg_no</b>		
	<b>Access level:</b> 3	<b>Calculated:</b> -	<b>Data type:</b> Unsigned16
	<b>Can be changed:</b> T, U	<b>Scaling:</b> -	<b>Dynamic index:</b> -
	<b>Unit group:</b> -	<b>Unit selection:</b> -	<b>Function diagram:</b> 8050, 8075
	<b>Min:</b>	<b>Max:</b>	<b>Factory setting:</b>
	0	65535	0
<b>Description:</b>	Selects faults or alarms for which the message type should be changed.		
<b>Dependency:</b>	Selects the fault or alarm selection and sets the required type of message realized under the same index. See also: p2119		
	<b>Note</b>		
	Re-parameterization is also possible if a message is present. The change only becomes effective after the message has gone.		

<b>p2119[0...19]</b>	<b>Change message type type / Change type type</b>		
	<b>Access level:</b> 3	<b>Calculated:</b> -	<b>Data type:</b> Integer16
	<b>Can be changed:</b> T, U	<b>Scaling:</b> -	<b>Dynamic index:</b> -
	<b>Unit group:</b> -	<b>Unit selection:</b> -	<b>Function diagram:</b> 8050, 8075
	<b>Min:</b> 1	<b>Max:</b> 3	<b>Factory setting:</b> 1
<b>Description:</b>	Sets the message type for the selected fault or alarm.		
<b>Value:</b>	1:           Fault (F) 2:           Alarm (A) 3:           No message (N)		
<b>Dependency:</b>	Selects the fault or alarm selection and sets the required type of message realized under the same index. See also: p2118		
	<b>Note</b> Re-parameterization is also possible if a message is present. The change only becomes effective after the message has gone. The message type can only be changed for messages with the appropriate identification (exception, value = 0). Example: F12345(A) --> Fault F12345 can be changed to alarm A12345. In this case, the message number that may be possibly entered in p2100[0...19] and p2126[0...19] is automatically removed.		

<b>r2121</b>	<b>CO: Counter alarm buffer changes / Alrm buff changed</b>		
	<b>Access level:</b> 3	<b>Calculated:</b> -	<b>Data type:</b> Unsigned16
	<b>Can be changed:</b> -	<b>Scaling:</b> -	<b>Dynamic index:</b> -
	<b>Unit group:</b> -	<b>Unit selection:</b> -	<b>Function diagram:</b> 8065
	<b>Min:</b> -	<b>Max:</b> -	<b>Factory setting:</b> -
<b>Description:</b>	This counter is incremented every time the alarm buffer changes.		
<b>Dependency:</b>	See also: r2110, r2122, r2123, r2124, r2125		

<b>r2122[0...63]</b>	<b>Alarm code / Alarm code</b>		
	<b>Access level:</b> 2	<b>Calculated:</b> -	<b>Data type:</b> Unsigned16
	<b>Can be changed:</b> -	<b>Scaling:</b> -	<b>Dynamic index:</b> -
	<b>Unit group:</b> -	<b>Unit selection:</b> -	<b>Function diagram:</b> 8050, 8065
	<b>Min:</b> -	<b>Max:</b> -	<b>Factory setting:</b> -
<b>Description:</b>	Displays the number of alarms that have occurred.		
<b>Dependency:</b>	See also: r2110, r2123, r2124, r2125, r2134, r2145, r2146, r3121, r3123		

**NOTICE**

The properties of the alarm buffer should be taken from the corresponding product documentation.

**Note**

The buffer parameters are cyclically updated in the background (refer to status signal in r2139).

Alarm buffer structure (general principle):

r2122[0], r2124[0], r2123[0], r2125[0] --> alarm 1 (the oldest)

...

r2122[7], r2124[7], r2123[7], r2125[7] --> Alarm 8 (the latest)

When the alarm buffer is full, the alarms that have gone are entered into the alarm history:

r2122[8], r2124[8], r2123[8], r2125[8] --> Alarm 1 (the latest)

...

r2122[63], r2124[63], r2123[63], r2125[63] --> alarm 56 (the oldest)

7.3 Parameter list

**r2123[0...63]**      **Alarm time received in milliseconds / t\_alarm recv ms**

<b>Access level:</b> 3	<b>Calculated:</b> -	<b>Data type:</b> Unsigned32
<b>Can be changed:</b> -	<b>Scaling:</b> -	<b>Dynamic index:</b> -
<b>Unit group:</b> -	<b>Unit selection:</b> -	<b>Function diagram:</b> 8050, 8065
<b>Min:</b> - [ms]	<b>Max:</b> - [ms]	<b>Factory setting:</b> - [ms]

**Description:** Displays the system runtime in milliseconds when the alarm occurred.

**Dependency:** See also: r2110, r2122, r2124, r2125, r2134, r2145, r2146, p8400

<b>NOTICE</b>
The time comprises r2145 (days) and r2123 (milliseconds).

**Note**  
The buffer parameters are cyclically updated in the background (refer to status signal in r2139).  
The structure of the alarm buffer and the assignment of the indices is shown in r2122.

**r2124[0...63]**      **Alarm value / Alarm value**

<b>Access level:</b> 3	<b>Calculated:</b> -	<b>Data type:</b> Integer32
<b>Can be changed:</b> -	<b>Scaling:</b> -	<b>Dynamic index:</b> -
<b>Unit group:</b> -	<b>Unit selection:</b> -	<b>Function diagram:</b> 8050, 8065
<b>Min:</b> -	<b>Max:</b> -	<b>Factory setting:</b> -

**Description:** Displays additional information about the active alarm (as integer number).

**Dependency:** See also: r2110, r2122, r2123, r2125, r2134, r2145, r2146, r3121, r3123

**Note**  
The buffer parameters are cyclically updated in the background (refer to status signal in r2139).  
The structure of the alarm buffer and the assignment of the indices is shown in r2122.

**r2125[0...63]**      **Alarm time removed in milliseconds / t\_alarm res ms**

<b>Access level:</b> 3	<b>Calculated:</b> -	<b>Data type:</b> Unsigned32
<b>Can be changed:</b> -	<b>Scaling:</b> -	<b>Dynamic index:</b> -
<b>Unit group:</b> -	<b>Unit selection:</b> -	<b>Function diagram:</b> 8050, 8065
<b>Min:</b> - [ms]	<b>Max:</b> - [ms]	<b>Factory setting:</b> - [ms]

**Description:** Displays the system runtime in milliseconds when the alarm was cleared.

**Dependency:** See also: r2110, r2122, r2123, r2124, r2134, r2145, r2146, p8400

<b>NOTICE</b>
The time comprises r2146 (days) and r2125 (milliseconds).

**Note**  
The buffer parameters are cyclically updated in the background (refer to status signal in r2139).  
The structure of the alarm buffer and the assignment of the indices is shown in r2122.

**p2126[0...19]**      **Change acknowledge mode fault number / Chng ackn F\_no**

<b>Access level:</b> 3	<b>Calculated:</b> -	<b>Data type:</b> Unsigned16
<b>Can be changed:</b> T, U	<b>Scaling:</b> -	<b>Dynamic index:</b> -
<b>Unit group:</b> -	<b>Unit selection:</b> -	<b>Function diagram:</b> 8050, 8075
<b>Min:</b> 0	<b>Max:</b> 65535	<b>Factory setting:</b> 0

**Description:** Selects the faults for which the acknowledge mode is to be changed



**Dependency:** Selects the faults and sets the required acknowledge mode realized under the same index  
See also: p2127

**Note**

Re-parameterization is also possible if a fault is present. The change only becomes effective after the fault has been resolved.

---

**p2127[0...19]      Change acknowledge mode mode / Chng ackn mode**

<b>Access level:</b> 3	<b>Calculated:</b> -	<b>Data type:</b> Integer16
<b>Can be changed:</b> T, U	<b>Scaling:</b> -	<b>Dynamic index:</b> -
<b>Unit group:</b> -	<b>Unit selection:</b> -	<b>Function diagram:</b> 8050, 8075
<b>Min:</b> 1	<b>Max:</b> 2	<b>Factory setting:</b> 1

**Description:** Sets the acknowledge mode for selected fault.

**Value:**  
1: Acknowledgment only using POWER ON  
2: Ack IMMEDIATELY after the fault cause has been removed

**Dependency:** Selects the faults and sets the required acknowledge mode realized under the same index  
See also: p2126

**NOTICE**

It is not possible to re-parameterize the acknowledge mode for a fault in the following cases:  
- fault number does not exist (exception value = 0).  
- Message type is not "fault" (F).  
- Acknowledge mode is not permissible for the set fault number.

**Note**

Re-parameterization is also possible if a fault is present. The change only becomes effective after the fault has been resolved.

The acknowledge mode can only be changed for faults with the appropriate identification.

Example:

F12345 and acknowledge mode = IMMEDIATELY (POWER ON)

--> The acknowledge mode can be changed from IMMEDIATELY to POWER ON.

---

**p2128[0...15]      Faults/alarms trigger selection / F/A trigger sel**

<b>Access level:</b> 3	<b>Calculated:</b> -	<b>Data type:</b> Unsigned16
<b>Can be changed:</b> T, U	<b>Scaling:</b> -	<b>Dynamic index:</b> -
<b>Unit group:</b> -	<b>Unit selection:</b> -	<b>Function diagram:</b> 8050, 8070
<b>Min:</b> 0	<b>Max:</b> 65535	<b>Factory setting:</b> 0

**Description:** Sets the faults/alarms for which a trigger signal should be generated in r2129.0...15.

**Dependency:** If the fault/alarm set in p2128[0...15] occurs, then the particular binector output r2129.0...15 is set.  
See also: r2129

---

**r2129.0...15      CO/BO: Faults/alarms trigger word / F/A trigger word**

<b>Access level:</b> 3	<b>Calculated:</b> -	<b>Data type:</b> Unsigned16
<b>Can be changed:</b> -	<b>Scaling:</b> -	<b>Dynamic index:</b> -
<b>Unit group:</b> -	<b>Unit selection:</b> -	<b>Function diagram:</b> 8070
<b>Min:</b> -	<b>Max:</b> -	<b>Factory setting:</b> -

**Description:** Display and BICO output for the trigger signals of the faults/alarms set in p2128[0...15].

<b>Bit field:</b>	<b>Bit</b>	<b>Signal name</b>	<b>1 signal</b>	<b>0 signal</b>	<b>FP</b>
	00	Trigger signal p2128[0]	ON	OFF	-

Parameters

7.3 Parameter list

01	Trigger signal p2128[1]	ON	OFF	-
02	Trigger signal p2128[2]	ON	OFF	-
03	Trigger signal p2128[3]	ON	OFF	-
04	Trigger signal p2128[4]	ON	OFF	-
05	Trigger signal p2128[5]	ON	OFF	-
06	Trigger signal p2128[6]	ON	OFF	-
07	Trigger signal p2128[7]	ON	OFF	-
08	Trigger signal p2128[8]	ON	OFF	-
09	Trigger signal p2128[9]	ON	OFF	-
10	Trigger signal p2128[10]	ON	OFF	-
11	Trigger signal p2128[11]	ON	OFF	-
12	Trigger signal p2128[12]	ON	OFF	-
13	Trigger signal p2128[13]	ON	OFF	-
14	Trigger signal p2128[14]	ON	OFF	-
15	Trigger signal p2128[15]	ON	OFF	-

**Dependency:** If the fault/alarm set in p2128[0...15] occurs, then the particular binector output r2129.0...15 is set.  
See also: p2128

**Note**

CO: r2129 = 0 --> None of the selected messages has occurred.  
CO: r2129 > 0 --> At least one of the selected messages has occurred.

**r2130[0...63] Fault time received in days / t\_fault recv days**

<b>Access level:</b> 3	<b>Calculated:</b> -	<b>Data type:</b> Unsigned16
<b>Can be changed:</b> -	<b>Scaling:</b> -	<b>Dynamic index:</b> -
<b>Unit group:</b> -	<b>Unit selection:</b> -	<b>Function diagram:</b> 8060
<b>Min:</b> -	<b>Max:</b> -	<b>Factory setting:</b> -

**Description:** Displays the system runtime in days when the fault occurred.

**Dependency:** See also: r0945, r0947, r0948, r0949, r2109, r2133, r2136, p8401

**NOTICE**

The time comprises r2130 (days) and r0948 (milliseconds).  
The value displayed in r2130 refers to January 1, 1970

**Note**

The buffer parameters are cyclically updated in the background (refer to status signal in r2139).

**r2131 CO: Actual fault code / Act fault code**

<b>Access level:</b> 2	<b>Calculated:</b> -	<b>Data type:</b> Unsigned16
<b>Can be changed:</b> -	<b>Scaling:</b> -	<b>Dynamic index:</b> -
<b>Unit group:</b> -	<b>Unit selection:</b> -	<b>Function diagram:</b> 8060
<b>Min:</b> -	<b>Max:</b> -	<b>Factory setting:</b> -

**Description:** Displays the code of the oldest active fault.

**Dependency:** See also: r3131, r3132

**Note**

0: No fault present.

<b>r2132</b>	<b>CO: Actual alarm code / Actual alarm code</b>				
	<b>Access level:</b> 2	<b>Calculated:</b> -	<b>Data type:</b> Unsigned16		
	<b>Can be changed:</b> -	<b>Scaling:</b> -	<b>Dynamic index:</b> -		
	<b>Unit group:</b> -	<b>Unit selection:</b> -	<b>Function diagram:</b> 8065		
	<b>Min:</b>	<b>Max:</b>	<b>Factory setting:</b>		
	-	-	-		
<b>Description:</b>	Displays the code of the last alarm that occurred.				
	<b>Note</b>				
	0: No alarm present.				
<b>r2133[0...63]</b>	<b>Fault value for float values / Fault val float</b>				
	<b>Access level:</b> 3	<b>Calculated:</b> -	<b>Data type:</b> FloatingPoint32		
	<b>Can be changed:</b> -	<b>Scaling:</b> -	<b>Dynamic index:</b> -		
	<b>Unit group:</b> -	<b>Unit selection:</b> -	<b>Function diagram:</b> 8060		
	<b>Min:</b>	<b>Max:</b>	<b>Factory setting:</b>		
	-	-	-		
<b>Description:</b>	Displays additional information about the fault that occurred for float values.				
<b>Dependency:</b>	See also: r0945, r0947, r0948, r0949, r2109, r2130, r2136				
	<b>Note</b>				
	The buffer parameters are cyclically updated in the background (refer to status signal in r2139).				
<b>r2134[0...63]</b>	<b>Alarm value for float values / Alarm value float</b>				
	<b>Access level:</b> 3	<b>Calculated:</b> -	<b>Data type:</b> FloatingPoint32		
	<b>Can be changed:</b> -	<b>Scaling:</b> -	<b>Dynamic index:</b> -		
	<b>Unit group:</b> -	<b>Unit selection:</b> -	<b>Function diagram:</b> 8065		
	<b>Min:</b>	<b>Max:</b>	<b>Factory setting:</b>		
	-	-	-		
<b>Description:</b>	Displays additional information about the active alarm for float values.				
<b>Dependency:</b>	See also: r2110, r2122, r2123, r2124, r2125, r2145, r2146, r3121, r3123				
	<b>Note</b>				
	The buffer parameters are cyclically updated in the background (refer to status signal in r2139).				
<b>r2135.12...15</b>	<b>CO/BO: Status word faults/alarms 2 / ZSW fault/alarm 2</b>				
	<b>Access level:</b> 2	<b>Calculated:</b> -	<b>Data type:</b> Unsigned16		
	<b>Can be changed:</b> -	<b>Scaling:</b> -	<b>Dynamic index:</b> -		
	<b>Unit group:</b> -	<b>Unit selection:</b> -	<b>Function diagram:</b> 2548		
	<b>Min:</b>	<b>Max:</b>	<b>Factory setting:</b>		
	-	-	-		
<b>Description:</b>	Display and BICO output for the second status word of faults and alarms.				
<b>Bit field:</b>	<b>Bit</b>	<b>Signal name</b>	<b>1 signal</b>	<b>0 signal</b>	<b>FP</b>
	12	Fault motor overtemperature	Yes	No	8016
	13	Fault power unit thermal overload	Yes	No	8021
	14	Alarm motor overtemperature	Yes	No	8016
	15	Alarm power unit thermal overload	Yes	No	8021

7.3 Parameter list

**r2136[0...63]**      **Fault time removed in days / t\_ft resolv days**

<b>Access level:</b> 3	<b>Calculated:</b> -	<b>Data type:</b> Unsigned16
<b>Can be changed:</b> -	<b>Scaling:</b> -	<b>Dynamic index:</b> -
<b>Unit group:</b> -	<b>Unit selection:</b> -	<b>Function diagram:</b> 8060
<b>Min:</b>	<b>Max:</b>	<b>Factory setting:</b>
-	-	-

**Description:** Displays the system runtime in days when the fault was removed.  
**Dependency:** See also: r0945, r0947, r0948, r0949, r2109, r2130, r2133, p8401

**NOTICE**  
 The time comprises r2136 (days) and r2109 (milliseconds).

**Note**  
 The buffer parameters are cyclically updated in the background (refer to status signal in r2139).

**r2138.7...15**      **CO/BO: Control word faults/alarms / STW fault/alarm**

<b>Access level:</b> 2	<b>Calculated:</b> -	<b>Data type:</b> Unsigned16
<b>Can be changed:</b> -	<b>Scaling:</b> -	<b>Dynamic index:</b> -
<b>Unit group:</b> -	<b>Unit selection:</b> -	<b>Function diagram:</b> 2546
<b>Min:</b>	<b>Max:</b>	<b>Factory setting:</b>
-	-	-

**Description:** Display and BICO output for the control word of faults and alarms.

<b>Bit field:</b>	<b>Bit</b>	<b>Signal name</b>	<b>1 signal</b>	<b>0 signal</b>	<b>FP</b>
	07	Acknowledge fault	Yes	No	8060
	10	External alarm 1 (A07850) effective	Yes	No	8065
	11	External alarm 2 (A07851) effective	Yes	No	8065
	12	External alarm 3 (A07852) effective	Yes	No	8065
	13	External fault 1 (F07860) effective	Yes	No	8060
	14	External fault 2 (F07861) effective	Yes	No	8060
	15	External fault 3 (F07862) effective	Yes	No	8060

**Dependency:** See also: p2103, p2104, p2105, p2106, p2107, p2108, p2112, p2116, p2117, p3110, p3111, p3112

**r2139.0...15**      **CO/BO: Status word faults/alarms 1 / ZSW fault/alarm 1**

<b>Access level:</b> 2	<b>Calculated:</b> -	<b>Data type:</b> Unsigned16
<b>Can be changed:</b> -	<b>Scaling:</b> -	<b>Dynamic index:</b> -
<b>Unit group:</b> -	<b>Unit selection:</b> -	<b>Function diagram:</b> 2548
<b>Min:</b>	<b>Max:</b>	<b>Factory setting:</b>
-	-	-

**Description:** Display and BICO output for status word 1 of faults and alarms.

<b>Bit field:</b>	<b>Bit</b>	<b>Signal name</b>	<b>1 signal</b>	<b>0 signal</b>	<b>FP</b>
	00	Being acknowledged	Yes	No	-
	01	Acknowledgment required	Yes	No	-
	03	Fault present	Yes	No	8060
	06	Internal message 1 present	Yes	No	-
	07	Alarm present	Yes	No	8065
	08	Internal message 2 present	Yes	No	-
	11	Alarm class bit 0	High	Low	-
	12	Alarm class bit 1	High	Low	-
	13	Maintenance required	Yes	No	-
	14	Maintenance urgently required	Yes	No	-

15	Fault gone/can be acknowledged	Yes	No	-
----	--------------------------------	-----	----	---

---

**Note**

For bit 03, 07:  
These bits are set if at least one fault/alarm occurs. Data is entered into the fault/alarm buffer with delay. This is the reason that the fault/alarm buffer should only be read if, after "fault present" or "alarm present" has occurred, a change in the buffer was also detected (r0944, r9744, r2121).

For bit 06, 08:  
These status bits are used for internal diagnostic purposes only.

For bits 11, 12:  
These status bits are used for the classification of internal alarm classes and are intended for diagnostic purposes only on certain automation systems with integrated SINAMICS functionality.

---

<b>p2140[0...n]</b>	<b>Hysteresis speed 2 / n_hysteresis 2</b>			
	<b>Access level:</b> 3	<b>Calculated:</b> CALC_MOD_LIM_REF	<b>Data type:</b> FloatingPoint32	
	<b>Can be changed:</b> T, U	<b>Scaling:</b> -	<b>Dynamic index:</b> DDS, p0180	
	<b>Unit group:</b> 3_1	<b>Unit selection:</b> p0505	<b>Function diagram:</b> 8010	
	<b>Min:</b> 0.00 [rpm]	<b>Max:</b> 300.00 [rpm]	<b>Factory setting:</b> 90.00 [rpm]	
<b>Description:</b>	Sets the hysteresis speed (bandwidth) for the following signals: " n_act  <= speed threshold value 2" (BO: r2197.1) " n_act  > speed threshold value 2" (BO: r2197.2)			
<b>Dependency:</b>	See also: p2155, r2197			

---

<b>p2141[0...n]</b>	<b>Speed threshold 1 / n_thresh val 1</b>			
	<b>Access level:</b> 3	<b>Calculated:</b> CALC_MOD_LIM_REF	<b>Data type:</b> FloatingPoint32	
	<b>Can be changed:</b> T, U	<b>Scaling:</b> -	<b>Dynamic index:</b> DDS, p0180	
	<b>Unit group:</b> 3_1	<b>Unit selection:</b> p0505	<b>Function diagram:</b> 8010	
	<b>Min:</b> 0.00 [rpm]	<b>Max:</b> 210000.00 [rpm]	<b>Factory setting:</b> 5.00 [rpm]	
<b>Description:</b>	Sets the speed threshold value for the signal "f or n comparison value reached or exceeded" (BO: r2199.1).			
<b>Dependency:</b>	See also: p2142, r2199			

---

<b>p2142[0...n]</b>	<b>Hysteresis speed 1 / n_hysteresis 1</b>			
	<b>Access level:</b> 3	<b>Calculated:</b> CALC_MOD_LIM_REF	<b>Data type:</b> FloatingPoint32	
	<b>Can be changed:</b> T, U	<b>Scaling:</b> -	<b>Dynamic index:</b> DDS, p0180	
	<b>Unit group:</b> 3_1	<b>Unit selection:</b> p0505	<b>Function diagram:</b> 8010	
	<b>Min:</b> 0.00 [rpm]	<b>Max:</b> 300.00 [rpm]	<b>Factory setting:</b> 2.00 [rpm]	
<b>Description:</b>	Sets the hysteresis speed (bandwidth) for the signal "f or n / v comparison value reached or exceeded" (BO: r2199.1).			
<b>Dependency:</b>	See also: p2141, r2199			

---

<b>p2144[0...n]</b>	<b>BI: Motor stall monitoring enable (negated) / Mot stall enab neg</b>			
	<b>Access level:</b> 3	<b>Calculated:</b> -	<b>Data type:</b> Unsigned32 / Binary	
	<b>Can be changed:</b> T, U	<b>Scaling:</b> -	<b>Dynamic index:</b> CDS, p0170	
	<b>Unit group:</b> -	<b>Unit selection:</b> -	<b>Function diagram:</b> 8012	
	<b>Min:</b> -	<b>Max:</b> -	<b>Factory setting:</b> 0	
<b>Description:</b>	Sets the signal source for the negated enable (0 = enable) of the motor stall monitoring.			

## Parameters

### 7.3 Parameter list

**Dependency:** See also: p2163, p2164, p2166, r2197, r2198  
See also: F07900

---

**Note**

When interconnecting the enable signal with r2197.7 then the stall signal is suppressed if there is no speed setpoint - actual value deviation.

---

---

**r2145[0...63]**     **Alarm time received in days / t\_alarm rcv days**

<b>Access level:</b> 3	<b>Calculated:</b> -	<b>Data type:</b> Unsigned16
<b>Can be changed:</b> -	<b>Scaling:</b> -	<b>Dynamic index:</b> -
<b>Unit group:</b> -	<b>Unit selection:</b> -	<b>Function diagram:</b> 8065
<b>Min:</b> -	<b>Max:</b> -	<b>Factory setting:</b> -

**Description:** Displays the system runtime in days when the alarm occurred.

**Dependency:** See also: r2110, r2122, r2123, r2124, r2125, r2134, r2146, p8401

---

**NOTICE**

The time comprises r2145 (days) and r2123 (milliseconds).

---

**Note**

The buffer parameters are cyclically updated in the background (refer to status signal in r2139).

---

---

**r2146[0...63]**     **Alarm time removed in days / t\_alarm res days**

<b>Access level:</b> 3	<b>Calculated:</b> -	<b>Data type:</b> Unsigned16
<b>Can be changed:</b> -	<b>Scaling:</b> -	<b>Dynamic index:</b> -
<b>Unit group:</b> -	<b>Unit selection:</b> -	<b>Function diagram:</b> 8065
<b>Min:</b> -	<b>Max:</b> -	<b>Factory setting:</b> -

**Description:** Displays the system runtime in days when the alarm was cleared.

**Dependency:** See also: r2110, r2122, r2123, r2124, r2125, r2134, r2145, p8401

---

**NOTICE**

The time comprises r2146 (days) and r2125 (milliseconds).

---

**Note**

The buffer parameters are cyclically updated in the background (refer to status signal in r2139).

---

---

**p2148[0...n]**     **BI: RFG active / RFG active**

<b>Access level:</b> 3	<b>Calculated:</b> CALC_MOD_LIM_REF	<b>Data type:</b> Unsigned32 / Binary
<b>Can be changed:</b> T, U	<b>Scaling:</b> -	<b>Dynamic index:</b> CDS, p0170
<b>Unit group:</b> -	<b>Unit selection:</b> -	<b>Function diagram:</b> 8011
<b>Min:</b> -	<b>Max:</b> -	<b>Factory setting:</b> 0

**Description:** Sets the signal source for the signal "ramp-function generator active" for the following signals/messages:  
"Speed setpoint - actual value deviation within tolerance t\_on" (BO: r2199.4)  
"Ramp-up/ramp-down completed" (BO: r2199.5)

---

**NOTICE**

The parameter may be protected as a result of p0922 or p2079 and cannot be changed.

---

**Note**

The binector input is automatically interconnected to r1199.2 as a default setting.

---

<b>p2149[0...n]</b>	<b>Monitoring configuration / Monit config</b>			
	<b>Access level:</b> 3	<b>Calculated:</b> -	<b>Data type:</b> Unsigned16	
	<b>Can be changed:</b> T, U	<b>Scaling:</b> -	<b>Dynamic index:</b> DDS, p0180	
	<b>Unit group:</b> -	<b>Unit selection:</b> -	<b>Function diagram:</b> -	
	<b>Min:</b> -	<b>Max:</b> -	<b>Factory setting:</b> 0000 1001 bin	
<b>Description:</b>	Sets the configuration for messages and monitoring functions.			
<b>Bit field:</b>	<b>Bit</b>	<b>Signal name</b>	<b>1 signal</b>	<b>0 signal</b>
	00	Enable alarm A07903	Yes	No
	01	Load monitoring only in the 1st quadrant	Yes	No
	03	n_act > p2155 own hysteresis	Yes	No
	05	Stall monitoring for encoderless speed control	Yes	No
<b>Dependency:</b>	See also: r2197 See also: A07903			
	<b>Note</b>			
	For bit 00: Alarm A07903 is output when the bit is set with r2197.7 = 0 (n_set <> n_act).			
	For bit 01: When the bit is set, the load monitoring is only executed in the 1st quadrant as a result of the positive characteristic parameters (p2182 ... p2190).			
	For bit 03: When the bit is set, r2197.1 and r2197.2 are determined using separate hysteresis functions.			
	For bit 05: When this bit is set, a change to open-loop speed controlled operation is only possible when the motor is stationary.			

<b>p2150[0...n]</b>	<b>Hysteresis speed 3 / n_hysteresis 3</b>			
	<b>Access level:</b> 3	<b>Calculated:</b> CALC_MOD_LIM_REF	<b>Data type:</b> FloatingPoint32	
	<b>Can be changed:</b> T, U	<b>Scaling:</b> -	<b>Dynamic index:</b> DDS, p0180	
	<b>Unit group:</b> 3_1	<b>Unit selection:</b> p0505	<b>Function diagram:</b> 8010, 8011, 8022	
	<b>Min:</b> 0.00 [rpm]	<b>Max:</b> 300.00 [rpm]	<b>Factory setting:</b> 2.00 [rpm]	
<b>Description:</b>	Sets the hysteresis speed (bandwidth) for the following signals: " n_act  < speed threshold value 3" (BO: r2199.0) "n_set >= 0" (BO: r2198.5) "n_act >= 0" (BO: r2197.3)			
<b>Dependency:</b>	See also: p2161, r2197, r2199			

<b>p2151[0...n]</b>	<b>Cl: Speed setpoint for messages/signals / n_set for msg</b>			
	<b>Access level:</b> 3	<b>Calculated:</b> -	<b>Data type:</b> Unsigned32 / FloatingPoint32	
	<b>Can be changed:</b> T	<b>Scaling:</b> p2000	<b>Dynamic index:</b> CDS, p0170	
	<b>Unit group:</b> -	<b>Unit selection:</b> -	<b>Function diagram:</b> 8011	
	<b>Min:</b> -	<b>Max:</b> -	<b>Factory setting:</b> 1170[0]	
<b>Description:</b>	Sets the signal source for the speed setpoint for the following messages: "Speed setpoint - actual value deviation within tolerance t_off" (BO: r2197.7) "Ramp-up/ramp-down completed" (BO: r2199.5) " n_set  < p2161" (BO: r2198.4) "n_set > 0" (BO: r2198.5)			

## 7.3 Parameter list

**Dependency:** See also: r2197, r2198, r2199

---

<b>p2153[0...n]</b>	<b>Speed actual value filter time constant / n_act_filt T</b>		
	<b>Access level:</b> 3	<b>Calculated:</b> -	<b>Data type:</b> FloatingPoint32
	<b>Can be changed:</b> T, U	<b>Scaling:</b> -	<b>Dynamic index:</b> DDS, p0180
	<b>Unit group:</b> -	<b>Unit selection:</b> -	<b>Function diagram:</b> 8010
	<b>Min:</b> 0 [ms]	<b>Max:</b> 1000000 [ms]	<b>Factory setting:</b> 0 [ms]
<b>Description:</b>	Sets the time constant of the PT1 element to smooth the speed / velocity actual value. The smoothed actual speed/velocity is compared with the threshold values and is only used for messages and signals.		
<b>Dependency:</b>	See also: r2169		

---

<b>p2155[0...n]</b>	<b>Speed threshold 2 / n_thresh val 2</b>		
	<b>Access level:</b> 3	<b>Calculated:</b> CALC_MOD_LIM_REF	<b>Data type:</b> FloatingPoint32
	<b>Can be changed:</b> T, U	<b>Scaling:</b> -	<b>Dynamic index:</b> DDS, p0180
	<b>Unit group:</b> 3_1	<b>Unit selection:</b> p0505	<b>Function diagram:</b> 8010
	<b>Min:</b> 0.00 [rpm]	<b>Max:</b> 210000.00 [rpm]	<b>Factory setting:</b> 900.00 [rpm]
<b>Description:</b>	Sets the speed threshold value for the following messages: " n_act  <= speed threshold value 2" (BO: r2197.1) " n_act  > speed threshold value 2" (BO: r2197.2)		
<b>Dependency:</b>	See also: p2140, r2197		

---

<b>p2156[0...n]</b>	<b>On delay comparison value reached / t_on cmpr val rchd</b>		
	<b>Access level:</b> 3	<b>Calculated:</b> -	<b>Data type:</b> FloatingPoint32
	<b>Can be changed:</b> T, U	<b>Scaling:</b> -	<b>Dynamic index:</b> DDS, p0180
	<b>Unit group:</b> -	<b>Unit selection:</b> -	<b>Function diagram:</b> 8010
	<b>Min:</b> 0.0 [ms]	<b>Max:</b> 10000.0 [ms]	<b>Factory setting:</b> 0.0 [ms]
<b>Description:</b>	Sets the switch-in delay time for the signal "comparison value reached" (BO: r2199.1).		
<b>Dependency:</b>	See also: p2141, p2142, r2199		

---

<b>p2161[0...n]</b>	<b>Speed threshold 3 / n_thresh val 3</b>		
	<b>Access level:</b> 3	<b>Calculated:</b> CALC_MOD_LIM_REF	<b>Data type:</b> FloatingPoint32
	<b>Can be changed:</b> T, U	<b>Scaling:</b> -	<b>Dynamic index:</b> DDS, p0180
	<b>Unit group:</b> 3_1	<b>Unit selection:</b> p0505	<b>Function diagram:</b> 8010, 8011
	<b>Min:</b> 0.00 [rpm]	<b>Max:</b> 210000.00 [rpm]	<b>Factory setting:</b> 5.00 [rpm]
<b>Description:</b>	Sets the speed threshold value for the signal " n_act  < speed threshold value 3" (BO: r2199.0).		
<b>Dependency:</b>	See also: p2150, r2199		



<b>p2162[0...n]</b>	<b>Hysteresis speed <math>n_{act} &gt; n_{max}</math> / Hyst <math>n_{act} &gt; n_{max}</math></b>		
	<b>Access level:</b> 3	<b>Calculated:</b> CALC_MOD_LIM_REF	<b>Data type:</b> FloatingPoint32
	<b>Can be changed:</b> T, U	<b>Scaling:</b> -	<b>Dynamic index:</b> DDS, p0180
	<b>Unit group:</b> 3_1	<b>Unit selection:</b> p0505	<b>Function diagram:</b> 8010
	<b>Min:</b> 0.00 [rpm]	<b>Max:</b> 60000.00 [rpm]	<b>Factory setting:</b> 0.00 [rpm]
<b>Description:</b>	Sets the hysteresis speed (bandwidth) for the signal " $n_{act} > n_{max}$ " (BO: r2197.6).		
<b>Dependency:</b>	See also: r1084, r1087, r2197		
	<b>NOTICE</b>		
	For p0322 = 0, the following applies: $p2162 \leq 0.1 * p0311$		
	For p0322 > 0, the following applies: $p2162 \leq 1.02 * p0322 - p1082$		
	If one of the conditions is violated, p2162 is appropriately and automatically reduced when exiting the commissioning mode.		
	<b>Note</b>		
	For a negative speed limit (r1087) the hysteresis is effective below the limit value and for a positive speed limit (r1084) above the limit value.		
	If significant overshoot occurs in the maximum speed range (e.g. due to load shedding), you are advised to increase the dynamic response of the speed controller (if possible). If this is insufficient, the hysteresis p2162 can only be increased by more than 10% of the rated speed when the maximum speed (p0322) of the motor is sufficiently greater than the speed limit p1082.		
<b>p2163[0...n]</b>	<b>Speed threshold 4 / <math>n_{thresh}</math> val 4</b>		
	<b>Access level:</b> 3	<b>Calculated:</b> CALC_MOD_LIM_REF	<b>Data type:</b> FloatingPoint32
	<b>Can be changed:</b> T, U	<b>Scaling:</b> -	<b>Dynamic index:</b> DDS, p0180
	<b>Unit group:</b> 3_1	<b>Unit selection:</b> p0505	<b>Function diagram:</b> 8011
	<b>Min:</b> 0.00 [rpm]	<b>Max:</b> 210000.00 [rpm]	<b>Factory setting:</b> 90.00 [rpm]
<b>Description:</b>	Sets the speed threshold value for the "speed setpoint - actual value deviation in tolerance $t_{off}$ " signal/message (BO: r2197.7).		
<b>Dependency:</b>	See also: p2164, p2166, r2197		
<b>p2164[0...n]</b>	<b>Hysteresis speed 4 / <math>n_{hysteresis}</math> 4</b>		
	<b>Access level:</b> 3	<b>Calculated:</b> CALC_MOD_LIM_REF	<b>Data type:</b> FloatingPoint32
	<b>Can be changed:</b> T, U	<b>Scaling:</b> -	<b>Dynamic index:</b> DDS, p0180
	<b>Unit group:</b> 3_1	<b>Unit selection:</b> p0505	<b>Function diagram:</b> 8011
	<b>Min:</b> 0.00 [rpm]	<b>Max:</b> 200.00 [rpm]	<b>Factory setting:</b> 2.00 [rpm]
<b>Description:</b>	Sets the hysteresis speed (bandwidth) for the "speed setpoint - actual value deviation in tolerance $t_{off}$ " signal/message (BO: r2197.7).		
<b>Dependency:</b>	See also: p2163, p2166, r2197		
<b>p2165[0...n]</b>	<b>Load monitoring stall monitoring upper threshold / Stall_mon up thr</b>		
	<b>Access level:</b> 3	<b>Calculated:</b> -	<b>Data type:</b> FloatingPoint32
	<b>Can be changed:</b> T, U	<b>Scaling:</b> -	<b>Dynamic index:</b> DDS, p0180
	<b>Unit group:</b> 3_1	<b>Unit selection:</b> p0505	<b>Function diagram:</b> 8013
	<b>Min:</b> 0.00 [rpm]	<b>Max:</b> 210000.00 [rpm]	<b>Factory setting:</b> 0.00 [rpm]

## 7.3 Parameter list

<b>Description:</b>	Sets the upper speed threshold of the stall monitoring of the pump or fan. The lower limit is formed by the speed threshold 1 of the load monitoring (p2182). The stall monitoring is active between p2182 and p2165.
<b>Dependency:</b>	The following applies: p2182 < p2165 See also: p2181, p2182, p2193 See also: A07891, F07894, A07926
<hr/>	
<b>Note</b>	
For p2165 = 0 or p2165 < p2182, the following applies: There is no special stall monitoring for the pump/fan, but only the remaining load monitoring functions (e.g. leakage monitoring for a pump) for the pump or fan are active.	
<hr/>	

<b>p2166[0...n]</b>	<b>Off delay <math>n_{act} = n_{set} / t_{del\_off} n_i = n_{so}</math></b>		
	<b>Access level:</b> 3	<b>Calculated:</b> -	<b>Data type:</b> FloatingPoint32
	<b>Can be changed:</b> T, U	<b>Scaling:</b> -	<b>Dynamic index:</b> DDS, p0180
	<b>Unit group:</b> -	<b>Unit selection:</b> -	<b>Function diagram:</b> 8011
	<b>Min:</b> 0.0 [ms]	<b>Max:</b> 10000.0 [ms]	<b>Factory setting:</b> 200.0 [ms]
<b>Description:</b>	Sets the switch-off delay time for the "speed setpoint - actual value deviation in tolerance t_off" signal/message (BO: r2197.7).		
<b>Dependency:</b>	See also: p2163, p2164, r2197		
<hr/>			

<b>p2167[0...n]</b>	<b>Switch-on delay <math>n_{act} = n_{set} / t_{on} n_{act} = n_{set}</math></b>		
	<b>Access level:</b> 3	<b>Calculated:</b> -	<b>Data type:</b> FloatingPoint32
	<b>Can be changed:</b> T, U	<b>Scaling:</b> -	<b>Dynamic index:</b> DDS, p0180
	<b>Unit group:</b> -	<b>Unit selection:</b> -	<b>Function diagram:</b> 8011
	<b>Min:</b> 0.0 [ms]	<b>Max:</b> 10000.0 [ms]	<b>Factory setting:</b> 200.0 [ms]
<b>Description:</b>	Sets the switch-on delay for the "speed setpoint - actual value deviation in tolerance t_on" signal/message (BO: r2199.4).		
<hr/>			

<b>p2168[0...n]</b>	<b>Load monitoring stall monitoring torque threshold / Stall_mon M_thresh</b>		
	<b>Access level:</b> 3	<b>Calculated:</b> -	<b>Data type:</b> FloatingPoint32
	<b>Can be changed:</b> T, U	<b>Scaling:</b> -	<b>Dynamic index:</b> DDS, p0180
	<b>Unit group:</b> 7_1	<b>Unit selection:</b> p0505	<b>Function diagram:</b> 8013
	<b>Min:</b> 0.00 [Nm]	<b>Max:</b> 20000000.00 [Nm]	<b>Factory setting:</b> 10000000.00 [Nm]
<b>Description:</b>	Sets the torque threshold of the stall monitoring of the pump or fan. If, in the monitored speed range from p2182 to p2165, the torque exceeds this threshold, then this is evaluated as either the motor having stalled or heavy-duty starting.		
<b>Dependency:</b>	For pumps, the following applies (p2193 = 4): - the leakage characteristic must lie below the torque threshold for the stall monitoring - the torque threshold for dry running operation must lie below the torque threshold for stall monitoring For fans, the following applies (p2193 = 5): - the torque threshold for the stall monitoring must lie above the torque threshold to identify belt breakage (p2191). See also: p2165, p2181, p2191, p2193 See also: A07891, F07894, A07926		
<hr/>			

**Note**

The following applies for p2168 = 0:  
The special stall monitoring for pump/fan is deactivated.  
Then, only the remaining load monitoring functions (e.g. the leakage monitoring for a pump) for pump or fan are realized.

<b>r2169</b>	<b>CO: Actual speed smoothed signals / n_act smth message</b>		
	<b>Access level:</b> 2	<b>Calculated:</b> -	<b>Data type:</b> FloatingPoint32
	<b>Can be changed:</b> -	<b>Scaling:</b> p2000	<b>Dynamic index:</b> -
	<b>Unit group:</b> 3_1	<b>Unit selection:</b> p0505	<b>Function diagram:</b> 8010
	<b>Min:</b> - [rpm]	<b>Max:</b> - [rpm]	<b>Factory setting:</b> - [rpm]
<b>Description:</b>	Display and connector output of the smoothed speed actual value for messages.		
<b>Dependency:</b>	See also: p2153		
<b>p2170[0...n]</b>	<b>Current threshold value / I_thres</b>		
	<b>Access level:</b> 3	<b>Calculated:</b> CALC_MOD_LIM_REF	<b>Data type:</b> FloatingPoint32
	<b>Can be changed:</b> T, U	<b>Scaling:</b> p2002	<b>Dynamic index:</b> DDS, p0180
	<b>Unit group:</b> 6_2	<b>Unit selection:</b> p0505	<b>Function diagram:</b> 8022
	<b>Min:</b> 0.00 [Arms]	<b>Max:</b> 10000.00 [Arms]	<b>Factory setting:</b> 0.00 [Arms]
<b>Description:</b>	Sets the absolute current threshold for the messages. "I_act >= I_threshold p2170" (BO: r2197.8) "I_act < I_threshold p2170" (BO: r2198.8)		
<b>Dependency:</b>	See also: p2171		
<b>p2171[0...n]</b>	<b>Current threshold value reached delay time / I_thres rch t_del</b>		
	<b>Access level:</b> 3	<b>Calculated:</b> -	<b>Data type:</b> Unsigned16
	<b>Can be changed:</b> T, U	<b>Scaling:</b> -	<b>Dynamic index:</b> DDS, p0180
	<b>Unit group:</b> -	<b>Unit selection:</b> -	<b>Function diagram:</b> 8022
	<b>Min:</b> 0 [ms]	<b>Max:</b> 10000 [ms]	<b>Factory setting:</b> 10 [ms]
<b>Description:</b>	Sets the delay time for the comparison of the current actual value (r0068) with the current threshold value (p2170).		
<b>Dependency:</b>	See also: p2170		
<b>p2172[0...n]</b>	<b>DC link voltage threshold value / Vdc thresh val</b>		
	<b>Access level:</b> 3	<b>Calculated:</b> -	<b>Data type:</b> FloatingPoint32
	<b>Can be changed:</b> T, U	<b>Scaling:</b> p2001	<b>Dynamic index:</b> DDS, p0180
	<b>Unit group:</b> 5_2	<b>Unit selection:</b> p0505	<b>Function diagram:</b> -
	<b>Min:</b> 0 [V]	<b>Max:</b> 2000 [V]	<b>Factory setting:</b> 800 [V]
<b>Description:</b>	Sets the DC link voltage threshold value for the following messages: "Vdc_act <= Vdc_threshold p2172" (BO: r2197.9) "Vdc_act > Vdc_threshold p2172" (BO: r2197.10)		
<b>Dependency:</b>	See also: p2173		
<b>p2173[0...n]</b>	<b>DC link voltage comparison delay time / t_del Vdc</b>		
	<b>Access level:</b> 3	<b>Calculated:</b> -	<b>Data type:</b> Unsigned16
	<b>Can be changed:</b> T, U	<b>Scaling:</b> -	<b>Dynamic index:</b> DDS, p0180
	<b>Unit group:</b> -	<b>Unit selection:</b> -	<b>Function diagram:</b> -
	<b>Min:</b> 0 [ms]	<b>Max:</b> 10000 [ms]	<b>Factory setting:</b> 10 [ms]
<b>Description:</b>	Sets the delay time for the comparison of the DC link voltage r0070 with the threshold value p2172.		
<b>Dependency:</b>	See also: p2172		

---

<b>p2175[0...n]</b>	<b>Motor blocked speed threshold / Mot lock n_thresh</b>		
	<b>Access level:</b> 3	<b>Calculated:</b> CALC_MOD_LIM_REF	<b>Data type:</b> FloatingPoint32
	<b>Can be changed:</b> T, U	<b>Scaling:</b> -	<b>Dynamic index:</b> DDS, p0180
	<b>Unit group:</b> 3_1	<b>Unit selection:</b> p0505	<b>Function diagram:</b> 8012
	<b>Min:</b> 0.00 [rpm]	<b>Max:</b> 210000.00 [rpm]	<b>Factory setting:</b> 120.00 [rpm]
<b>Description:</b>	Sets the speed threshold for the message "Motor blocked" (BO: r2198.6).		
<b>Dependency:</b>	See also: p0500, p2177, r2198 See also: F07900		

---

**Note**

The following applies for sensorless vector control for induction motors:

At low speeds in open-loop speed controlled operation (see p1755, p1756), a blocked motor cannot be detected.

---

<b>p2177[0...n]</b>	<b>Motor blocked delay time / Mot lock t_del</b>		
	<b>Access level:</b> 3	<b>Calculated:</b> CALC_MOD_LIM_REF	<b>Data type:</b> FloatingPoint32
	<b>Can be changed:</b> T, U	<b>Scaling:</b> -	<b>Dynamic index:</b> DDS, p0180
	<b>Unit group:</b> -	<b>Unit selection:</b> -	<b>Function diagram:</b> 8012
	<b>Min:</b> 0.000 [s]	<b>Max:</b> 65.000 [s]	<b>Factory setting:</b> 3.000 [s]
<b>Description:</b>	Sets the delay time for the message "Motor blocked" (BO: r2198.6).		
<b>Dependency:</b>	See also: p0500, p2175, r2198 See also: F07900		

---

**Note**

The following applies for sensorless vector control:

At low speeds a locked motor can only be detected if no change is made to open-loop speed controlled operation. If this is the case, the value in p2177 must be reduced accordingly (p2177 < p1758) before time p2177 has elapsed in order to detect the locked state reliably.

As countermeasure, it is generally also possible to set p1750.6. This is only not permitted if the drive is slowly reversed by the load at the torque limit (speed below p1755 for longer than p1758).

---

<b>p2178[0...n]</b>	<b>Motor stalled delay time / Mot stall t_del</b>		
	<b>Access level:</b> 3	<b>Calculated:</b> CALC_MOD_REG	<b>Data type:</b> FloatingPoint32
	<b>Can be changed:</b> T, U	<b>Scaling:</b> -	<b>Dynamic index:</b> DDS, p0180
	<b>Unit group:</b> -	<b>Unit selection:</b> -	<b>Function diagram:</b> 8012
	<b>Min:</b> 0.000 [s]	<b>Max:</b> 10.000 [s]	<b>Factory setting:</b> 0.010 [s]
<b>Description:</b>	Sets the delay time for the message "Motor stalled" (BO: r2198.7).		
<b>Dependency:</b>	See also: r2198		

---

**Note**

In the open-loop speed controlled operating range (see p1755, p1756), vector control stall monitoring depends on threshold p1745.

At higher speeds, the difference between flux setpoint r0083 and flux actual value r0084 is monitored.

---

<b>p2179[0...n]</b>	<b>Output load identification current limit / Outp_Id iden l_lim</b>		
	<b>Access level:</b> 3	<b>Calculated:</b> CALC_MOD_LIM_REF	<b>Data type:</b> FloatingPoint32
	<b>Can be changed:</b> T, U	<b>Scaling:</b> p2002	<b>Dynamic index:</b> DDS, p0180
	<b>Unit group:</b> 6_2	<b>Unit selection:</b> p0505	<b>Function diagram:</b> 8022
	<b>Min:</b> 0.00 [Arms]	<b>Max:</b> 1000.00 [Arms]	<b>Factory setting:</b> 0.00 [Arms]
<b>Description:</b>	Sets the current limit for output load identification. A missing output load is displayed using the "Output load not available" message (r2197.11 = 1). This message is output with a delay time (p2180).		
<b>Dependency:</b>	See also: p2180		
	<b>NOTICE</b>		
	For synchronous motors the output current can be almost zero under no load conditions.		
	<b>Note</b> Missing output load is signaled in the following cases: - the motor is not connected. - a phase failure has occurred.		
<b>p2180[0...n]</b>	<b>Output load detection delay time / Out_load det t_del</b>		
	<b>Access level:</b> 3	<b>Calculated:</b> -	<b>Data type:</b> Unsigned16
	<b>Can be changed:</b> T, U	<b>Scaling:</b> -	<b>Dynamic index:</b> DDS, p0180
	<b>Unit group:</b> -	<b>Unit selection:</b> -	<b>Function diagram:</b> 8022
	<b>Min:</b> 0 [ms]	<b>Max:</b> 10000 [ms]	<b>Factory setting:</b> 2000 [ms]
<b>Description:</b>	Sets the delay time for the message "output load not available" (r2197.11 = 1).		
<b>Dependency:</b>	See also: p2179		
<b>p2181[0...n]</b>	<b>Load monitoring response / Load monit resp</b>		
	<b>Access level:</b> 3	<b>Calculated:</b> -	<b>Data type:</b> Integer16
	<b>Can be changed:</b> T, U	<b>Scaling:</b> -	<b>Dynamic index:</b> DDS, p0180
	<b>Unit group:</b> -	<b>Unit selection:</b> -	<b>Function diagram:</b> 8013
	<b>Min:</b> 0	<b>Max:</b> 8	<b>Factory setting:</b> 0
<b>Description:</b>	Sets the response when evaluating the load monitoring.		
<b>Value:</b>	0: Load monitoring disabled 1: A07920 for torque/speed too low 2: A07921 for torque/speed too high 3: A07922 for torque/speed out of tolerance 4: F07923 for torque/speed too low 5: F07924 for torque/speed too high 6: F07925 for torque/speed out of tolerance 7: Pump/fan load monitoring as alarm 8: Pump/fan load monitoring as fault		
<b>Dependency:</b>	See also: p2182, p2183, p2184, p2185, p2186, p2187, p2188, p2189, p2190, p2192, p2193, r2198, p3230, p3231 See also: A07891, A07892, A07893, F07894, F07895, F07896, F07898, A07920, A07921, A07922, F07923, F07924, F07925		

**Note**

The response to the faults F07923 ... F07925 can be set.  
 This parameter setting has no effect on the generation of fault F07936.  
 p2181 = 7, 8 can only be combined with p2193 = 4, 5.

<b>p2182[0...n]</b>	<b>Load monitoring speed threshold value 1 / n_thresh 1</b>		
	<b>Access level:</b> 3	<b>Calculated:</b> -	<b>Data type:</b> FloatingPoint32
	<b>Can be changed:</b> T, U	<b>Scaling:</b> -	<b>Dynamic index:</b> DDS, p0180
	<b>Unit group:</b> 3_1	<b>Unit selection:</b> p0505	<b>Function diagram:</b> 8013
	<b>Min:</b> 0.00 [rpm]	<b>Max:</b> 210000.00 [rpm]	<b>Factory setting:</b> 150.00 [rpm]
<b>Description:</b>	Sets the speed/torque envelope curve for load monitoring. The envelope curve (upper and lower envelope curve) is defined as follows based on 3 speed thresholds: p2182 (n_threshold 1) --> p2185 (M_threshold 1, upper), p2186 (M_threshold 1, lower) p2183 (n_threshold 2) --> p2187 (M_threshold 2, upper), p2188 (M_threshold 2, lower) p2184 (n_threshold 3) --> p2189 (M_threshold 3, upper), p2190 (M_threshold 3, lower)		
<b>Dependency:</b>	The following applies: p2182 < p2183 < p2184 See also: p2183, p2184, p2185, p2186 See also: A07926		
	<b>Note</b>		
	In order that the load monitoring can reliably respond, the speed threshold p2182 should always be set lower than the minimum motor speed to be monitored.		

<b>p2183[0...n]</b>	<b>Load monitoring speed threshold value 2 / n_thresh 2</b>		
	<b>Access level:</b> 3	<b>Calculated:</b> -	<b>Data type:</b> FloatingPoint32
	<b>Can be changed:</b> T, U	<b>Scaling:</b> -	<b>Dynamic index:</b> DDS, p0180
	<b>Unit group:</b> 3_1	<b>Unit selection:</b> p0505	<b>Function diagram:</b> 8013
	<b>Min:</b> 0.00 [rpm]	<b>Max:</b> 210000.00 [rpm]	<b>Factory setting:</b> 900.00 [rpm]
<b>Description:</b>	Sets the speed/torque envelope curve for load monitoring. The envelope curve (upper and lower envelope curve) is defined as follows based on 3 speed thresholds: p2182 (n_threshold 1) --> p2185 (M_threshold 1, upper), p2186 (M_threshold 1, lower) p2183 (n_threshold 2) --> p2187 (M_threshold 2, upper), p2188 (M_threshold 2, lower) p2184 (n_threshold 3) --> p2189 (M_threshold 3, upper), p2190 (M_threshold 3, lower)		
<b>Dependency:</b>	The following applies: p2182 < p2183 < p2184 See also: p2182, p2184, p2187, p2188 See also: A07926		

<b>p2184[0...n]</b>	<b>Load monitoring speed threshold value 3 / n_thresh 3</b>		
	<b>Access level:</b> 3	<b>Calculated:</b> -	<b>Data type:</b> FloatingPoint32
	<b>Can be changed:</b> T, U	<b>Scaling:</b> -	<b>Dynamic index:</b> DDS, p0180
	<b>Unit group:</b> 3_1	<b>Unit selection:</b> p0505	<b>Function diagram:</b> 8013
	<b>Min:</b> 0.00 [rpm]	<b>Max:</b> 210000.00 [rpm]	<b>Factory setting:</b> 1500.00 [rpm]
<b>Description:</b>	Sets the speed/torque envelope curve for load monitoring. The envelope curve (upper and lower envelope curve) is defined as follows based on 3 speed thresholds: p2182 (n_threshold 1) --> p2185 (M_threshold 1, upper), p2186 (M_threshold 1, lower) p2183 (n_threshold 2) --> p2187 (M_threshold 2, upper), p2188 (M_threshold 2, lower) p2184 (n_threshold 3) --> p2189 (M_threshold 3, upper), p2190 (M_threshold 3, lower)		

**Dependency:** The following applies: p2182 < p2183 < p2184  
 See also: p2182, p2183, p2189, p2190  
 See also: A07926

**Note**

In order that the load monitoring can reliably respond, the speed threshold p2184 should always be set higher than the maximum motor speed to be monitored.

**p2185[0...n] Load monitoring torque threshold 1 upper / M\_thresh 1 upper****Access level:** 3**Calculated:** -**Data type:** FloatingPoint32**Can be changed:** T, U**Scaling:** -**Dynamic index:** DDS, p0180**Unit group:** 7\_1**Unit selection:** p0505**Function diagram:** 8013**Min:****Max:****Factory setting:**

0.00 [Nm]

20000000.00 [Nm]

10000000.00 [Nm]

**Description:** Sets the speed/torque envelope curve for load monitoring.

**Dependency:** The following applies: p2185 > p2186  
 See also: p2182, p2186  
 See also: A07926

**Note**

The upper envelope curve is defined by p2185, p2187 and p2189.

**p2186[0...n] Load monitoring torque threshold 1 lower / M\_thresh 1 lower****Access level:** 3**Calculated:** -**Data type:** FloatingPoint32**Can be changed:** T, U**Scaling:** -**Dynamic index:** DDS, p0180**Unit group:** 7\_1**Unit selection:** p0505**Function diagram:** 8013**Min:****Max:****Factory setting:**

0.00 [Nm]

20000000.00 [Nm]

0.00 [Nm]

**Description:** Sets the speed/torque envelope curve for load monitoring.

**Dependency:** The following applies: p2186 < p2185  
 See also: p2182, p2185  
 See also: A07926

**Note**

The lower envelope curve is defined by p2186, p2188 and p2190.

**p2187[0...n] Load monitoring torque threshold 2 upper / M\_thresh 2 upper****Access level:** 3**Calculated:** -**Data type:** FloatingPoint32**Can be changed:** T, U**Scaling:** -**Dynamic index:** DDS, p0180**Unit group:** 7\_1**Unit selection:** p0505**Function diagram:** 8013**Min:****Max:****Factory setting:**

0.00 [Nm]

20000000.00 [Nm]

10000000.00 [Nm]

**Description:** Sets the speed/torque envelope curve for load monitoring.

**Dependency:** The following applies: p2187 > p2188  
 See also: p2183, p2188  
 See also: A07926

**Note**

The upper envelope curve is defined by p2185, p2187 and p2189.

<b>p2188[0...n]</b>	<b>Load monitoring torque threshold 2 lower / M_thresh 2 lower</b>		
	<b>Access level:</b> 3	<b>Calculated:</b> -	<b>Data type:</b> FloatingPoint32
	<b>Can be changed:</b> T, U	<b>Scaling:</b> -	<b>Dynamic index:</b> DDS, p0180
	<b>Unit group:</b> 7_1	<b>Unit selection:</b> p0505	<b>Function diagram:</b> 8013
	<b>Min:</b> 0.00 [Nm]	<b>Max:</b> 20000000.00 [Nm]	<b>Factory setting:</b> 0.00 [Nm]
<b>Description:</b>	Sets the speed/torque envelope curve for load monitoring.		
<b>Dependency:</b>	The following applies: p2188 < p2187 See also: p2183, p2187 See also: A07926		
	<b>Note</b> The lower envelope curve is defined by p2186, p2188 and p2190.		
<b>p2189[0...n]</b>	<b>Load monitoring torque threshold 3 upper / M_thresh 3 upper</b>		
	<b>Access level:</b> 3	<b>Calculated:</b> -	<b>Data type:</b> FloatingPoint32
	<b>Can be changed:</b> T, U	<b>Scaling:</b> -	<b>Dynamic index:</b> DDS, p0180
	<b>Unit group:</b> 7_1	<b>Unit selection:</b> p0505	<b>Function diagram:</b> 8013
	<b>Min:</b> 0.00 [Nm]	<b>Max:</b> 20000000.00 [Nm]	<b>Factory setting:</b> 10000000.00 [Nm]
<b>Description:</b>	Sets the speed/torque envelope curve for load monitoring.		
<b>Dependency:</b>	The following applies: p2189 > p2190 See also: p2184, p2190 See also: A07926		
	<b>Note</b> The upper envelope curve is defined by p2185, p2187 and p2189.		
<b>p2190[0...n]</b>	<b>Load monitoring torque threshold 3 lower / M_thresh 3 lower</b>		
	<b>Access level:</b> 3	<b>Calculated:</b> -	<b>Data type:</b> FloatingPoint32
	<b>Can be changed:</b> T, U	<b>Scaling:</b> -	<b>Dynamic index:</b> DDS, p0180
	<b>Unit group:</b> 7_1	<b>Unit selection:</b> p0505	<b>Function diagram:</b> 8013
	<b>Min:</b> 0.00 [Nm]	<b>Max:</b> 20000000.00 [Nm]	<b>Factory setting:</b> 0.00 [Nm]
<b>Description:</b>	Sets the speed/torque envelope curve for load monitoring.		
<b>Dependency:</b>	The following applies: p2190 < p2189 See also: p2184, p2189 See also: A07926		
	<b>Note</b> The lower envelope curve is defined by p2186, p2188 and p2190.		
<b>p2191[0...n]</b>	<b>Load monitoring torque threshold no load / M_thresh no load</b>		
	<b>Access level:</b> 3	<b>Calculated:</b> -	<b>Data type:</b> FloatingPoint32
	<b>Can be changed:</b> T, U	<b>Scaling:</b> -	<b>Dynamic index:</b> DDS, p0180
	<b>Unit group:</b> 7_1	<b>Unit selection:</b> p0505	<b>Function diagram:</b> 8013
	<b>Min:</b> 0.00 [Nm]	<b>Max:</b> 20000000.00 [Nm]	<b>Factory setting:</b> 0.00 [Nm]
<b>Description:</b>	Setting of the torque threshold to identify dry running operation for pumps or belt breakage for fans.		



**Dependency:** The following applies: p2191 < p2168 if p2168 <> 0  
 See also: p2181, p2182, p2184, p2193  
 See also: A07892, F07895, A07926

**Note**

For the setting p2191 = 0, the monitoring for dry running operation or belt breakage is deactivated.  
 Pre-assignment: p2191 = 5 % of the rated motor torque (p0333).

---

**p2192[0...n]**      **Load monitoring delay time / Load monit t\_del**

<b>Access level:</b> 3	<b>Calculated:</b> -	<b>Data type:</b> FloatingPoint32
<b>Can be changed:</b> T, U	<b>Scaling:</b> -	<b>Dynamic index:</b> DDS, p0180
<b>Unit group:</b> -	<b>Unit selection:</b> -	<b>Function diagram:</b> 8013
<b>Min:</b> 0.00 [s]	<b>Max:</b> 65.00 [s]	<b>Factory setting:</b> 10.00 [s]

**Description:** Sets the delay time to evaluate the load monitoring.

---

**p2193[0...n]**      **Load monitoring configuration / Load monit config**

<b>Access level:</b> 3	<b>Calculated:</b> -	<b>Data type:</b> Integer16
<b>Can be changed:</b> T, U	<b>Scaling:</b> -	<b>Dynamic index:</b> DDS, p0180
<b>Unit group:</b> -	<b>Unit selection:</b> -	<b>Function diagram:</b> 8013
<b>Min:</b> 0	<b>Max:</b> 5	<b>Factory setting:</b> 1

**Description:** Sets the load monitoring configuration.

**Value:**

0:	Monitoring switched out
1:	Monitoring torque and load drop
2:	Monitoring speed and load drop
3:	Monitoring load drop
4:	Monitoring pump and load failure
5:	Monitoring fan and load failure

**Dependency:** See also: p2182, p2183, p2184, p2185, p2186, p2187, p2188, p2189, p2190, p2192, r2198, p3230, p3231, p3232  
 See also: A07891, A07892, A07893, F07894, F07895, F07896, F07898, A07920, A07921, A07922, F07923, F07924, F07925, F07936

**Note**

p2193 = 4, 5 can only be combined with p2181 = 7, 8.

---

**r2197.0...13**      **CO/BO: Status word monitoring 1 / ZSW monitor 1**

<b>Access level:</b> 3	<b>Calculated:</b> -	<b>Data type:</b> Unsigned16
<b>Can be changed:</b> -	<b>Scaling:</b> -	<b>Dynamic index:</b> -
<b>Unit group:</b> -	<b>Unit selection:</b> -	<b>Function diagram:</b> 2534
<b>Min:</b> -	<b>Max:</b> -	<b>Factory setting:</b> -

**Description:** Display and BICO output for the first status word of the monitoring functions.

<b>Bit field:</b>	<b>Bit</b>	<b>Signal name</b>	<b>1 signal</b>	<b>0 signal</b>	<b>FP</b>
	00	n_act  <= n_min p1080	Yes	No	8022
	01	n_act  <= speed threshold value 2 p2155	Yes	No	8010
	02	n_act  > speed threshold value 2 p2155	Yes	No	8010
	03	n_act >= 0	Yes	No	8011
	04	n_act  >= n_set	Yes	No	8022
	05	n_act  <= n_standstill p1226	Yes	No	8022
	06	n_act  > n_max	Yes	No	8010

7.3 Parameter list

07	Speed setpoint - actual value deviation in tolerance t_off	Yes	No	8011
08	I_act >= I_threshold value p2170	Yes	No	8022
09	Vdc_act <= Vdc_threshold value p2172	Yes	No	8022
10	Vdc_act > Vdc_threshold value p2172	Yes	No	8022
11	Output load is not present	Yes	No	8022
13	n_act  > n_max (F07901)	Yes	No	-

**NOTICE**  
 For bit 06:  
 When the overspeed is reached, this bit is set and F07901 output immediately following this. The bit is canceled again as soon as the next pulse inhibit is present.

**Note**

For bit 00:  
 The threshold value is set in p1080 and the hysteresis in p2150.  
 For bit 01, 02:  
 The threshold value is set in p2155 and the hysteresis in p2140.  
 For bit 03:  
 1 signal direction of rotation positive.  
 0 signal: direction of rotation negative.  
 The hysteresis is set in p2150.  
 For bit 04:  
 The threshold value is set in r1119 and the hysteresis in p2150.  
 For bit 05:  
 The threshold value is set in p1226 and the delay time in p1228.  
 For bit 06:  
 The hysteresis is set in p2162.  
 For bit 07:  
 The threshold value is set in p2163 and the hysteresis is set in p2164.  
 For bit 08:  
 The threshold value is set in p2170 and the delay time in p2171.  
 For bit 09, 10:  
 The threshold value is set in p2172 and the delay time in p2173.  
 For bit 11:  
 The threshold value is set in p2179 and the delay time in p2180.  
 For bit 13:  
 Only for internal Siemens use.

r2198.4...12

**CO/BO: Status word monitoring 2 / ZSW monitor 2**

<b>Access level:</b> 3	<b>Calculated:</b> -	<b>Data type:</b> Unsigned16
<b>Can be changed:</b> -	<b>Scaling:</b> -	<b>Dynamic index:</b> -
<b>Unit group:</b> -	<b>Unit selection:</b> -	<b>Function diagram:</b> 2536
<b>Min:</b>	<b>Max:</b>	<b>Factory setting:</b>
-	-	-

**Description:**

Display and BICO output for the second status word of the monitoring functions.

**Bit field:**

Bit	Signal name	1 signal	0 signal	FP
04	n_set  < p2161	Yes	No	8011
05	n_set > 0	Yes	No	8011
06	Motor blocked	Yes	No	8012
07	Motor stalled	Yes	No	8012
08	I_act  < I_threshold value p2170	Yes	No	8022
11	Load in the alarm range	Yes	No	8013
12	Load in the fault range	Yes	No	8013

**Note**

For bit 12:

This bit is reset after the fault cause disappears, even if the fault itself is still present.

**r2199.0...5****CO/BO: Status word monitoring 3 / ZSW monitor 3****Access level:** 3**Calculated:** -**Data type:** Unsigned16**Can be changed:** -**Scaling:** -**Dynamic index:** -**Unit group:** -**Unit selection:** -**Function diagram:** 2537**Min:****Max:****Factory setting:**

-

-

-

**Description:**

Display and BICO output for the third status word of the monitoring functions.

**Bit field:**

Bit	Signal name	1 signal	0 signal	FP
00	n_act  < speed threshold value 3	Yes	No	8010
01	f or n comparison value reached or exceeded	Yes	No	8010
04	Speed setpoint - actual value deviation in tolerance t_on	Yes	No	8011
05	Ramp-up/ramp-down completed	Yes	No	8011

**Note**

For bit 00:

The speed threshold value 3 is set in p2161.

For bit 01:

The comparison value is set in p2141. We recommend setting the hysteresis (p2142) for canceling the bit to a value lower than that in p2141. Otherwise, the bit is not reset.

**p2200[0...n]****BI: Technology controller enable / Tec\_ctrl enable****Access level:** 2**Calculated:** -**Data type:** Unsigned32 / Binary**Can be changed:** T**Scaling:** -**Dynamic index:** CDS, p0180**Unit group:** -**Unit selection:** -**Function diagram:** 7958**Min:****Max:****Factory setting:**

-

-

0

**Description:**

Sets the signal source to switch in/switch out the technology controller.

The technology controller is switched in with a 1 signal.

**p2201[0...n]****CO: Technology controller fixed value 1 / Tec\_ctrl fix val1****Access level:** 2**Calculated:** -**Data type:** FloatingPoint32**Can be changed:** T, U**Scaling:** PERCENT**Dynamic index:** DDS, p0180**Unit group:** 9\_1**Unit selection:** p0595**Function diagram:** 7950, 7951**Min:****Max:****Factory setting:**

-200.00 [%]

200.00 [%]

10.00 [%]

**Description:**

Sets the value for fixed value 1 of the technology controller.

**Dependency:**

See also: p2220, p2221, p2222, p2223, r2224, r2229

**NOTICE**

A BICO interconnection to a parameter that belongs to a drive data set always acts on the effective data set.

**p2202[0...n]****CO: Technology controller fixed value 2 / Tec\_ctr fix val 2****Access level:** 2**Calculated:** -**Data type:** FloatingPoint32**Can be changed:** T, U**Scaling:** PERCENT**Dynamic index:** DDS, p0180**Unit group:** 9\_1**Unit selection:** p0595**Function diagram:** 7950, 7951**Min:****Max:****Factory setting:**

-200.00 [%]

200.00 [%]

20.00 [%]

## Parameters

### 7.3 Parameter list

**Description:** Sets the value for fixed value 2 of the technology controller.

**Dependency:** See also: p2220, p2221, p2222, p2223, r2224, r2229

<b>NOTICE</b>
---------------

A BICO interconnection to a parameter that belongs to a drive data set always acts on the effective data set.
---

---

#### p2203[0...n] CO: Technology controller fixed value 3 / Tec\_ctr fix val 3

**Access level:** 2

**Calculated:** -

**Data type:** FloatingPoint32

**Can be changed:** T, U

**Scaling:** PERCENT

**Dynamic index:** DDS, p0180

**Unit group:** 9\_1

**Unit selection:** p0595

**Function diagram:** 7950, 7951

**Min:**

**Max:**

**Factory setting:**

-200.00 [%]

200.00 [%]

30.00 [%]

**Description:** Sets the value for fixed value 3 of the technology controller.

**Dependency:** See also: p2220, p2221, p2222, p2223, r2224, r2229

<b>NOTICE</b>
---------------

A BICO interconnection to a parameter that belongs to a drive data set always acts on the effective data set.
---

---

#### p2204[0...n] CO: Technology controller fixed value 4 / Tec\_ctr fix val 4

**Access level:** 2

**Calculated:** -

**Data type:** FloatingPoint32

**Can be changed:** T, U

**Scaling:** PERCENT

**Dynamic index:** DDS, p0180

**Unit group:** 9\_1

**Unit selection:** p0595

**Function diagram:** 7950, 7951

**Min:**

**Max:**

**Factory setting:**

-200.00 [%]

200.00 [%]

40.00 [%]

**Description:** Sets the value for fixed value 4 of the technology controller.

**Dependency:** See also: p2220, p2221, p2222, p2223, r2224, r2229

<b>NOTICE</b>
---------------

A BICO interconnection to a parameter that belongs to a drive data set always acts on the effective data set.
---

---

#### p2205[0...n] CO: Technology controller fixed value 5 / Tec\_ctr fix val 5

**Access level:** 2

**Calculated:** -

**Data type:** FloatingPoint32

**Can be changed:** T, U

**Scaling:** PERCENT

**Dynamic index:** DDS, p0180

**Unit group:** 9\_1

**Unit selection:** p0595

**Function diagram:** 7950

**Min:**

**Max:**

**Factory setting:**

-200.00 [%]

200.00 [%]

50.00 [%]

**Description:** Sets the value for fixed value 5 of the technology controller.

**Dependency:** See also: p2220, p2221, p2222, p2223, r2224, r2229

<b>NOTICE</b>
---------------

A BICO interconnection to a parameter that belongs to a drive data set always acts on the effective data set.
---

---

#### p2206[0...n] CO: Technology controller fixed value 6 / Tec\_ctr fix val 6

**Access level:** 2

**Calculated:** -

**Data type:** FloatingPoint32

**Can be changed:** T, U

**Scaling:** PERCENT

**Dynamic index:** DDS, p0180

**Unit group:** 9\_1

**Unit selection:** p0595

**Function diagram:** 7950

**Min:**

**Max:**

**Factory setting:**

-200.00 [%]

200.00 [%]

60.00 [%]

**Description:** Sets the value for fixed value 6 of the technology controller.

**Dependency:** See also: p2220, p2221, p2222, p2223, r2224, r2229

<b>NOTICE</b>
A BICO interconnection to a parameter that belongs to a drive data set always acts on the effective data set.

<b>p2207[0...n]</b>	<b>CO: Technology controller fixed value 7 / Tec_ctr fix val 7</b>		
	<b>Access level:</b> 2	<b>Calculated:</b> -	<b>Data type:</b> FloatingPoint32
	<b>Can be changed:</b> T, U	<b>Scaling:</b> PERCENT	<b>Dynamic index:</b> DDS, p0180
	<b>Unit group:</b> 9_1	<b>Unit selection:</b> p0595	<b>Function diagram:</b> 7950
	<b>Min:</b> -200.00 [%]	<b>Max:</b> 200.00 [%]	<b>Factory setting:</b> 70.00 [%]
<b>Description:</b>	Sets the value for fixed value 7 of the technology controller.		
<b>Dependency:</b>	See also: p2220, p2221, p2222, p2223, r2224, r2229		

<b>NOTICE</b>
A BICO interconnection to a parameter that belongs to a drive data set always acts on the effective data set.

<b>p2208[0...n]</b>	<b>CO: Technology controller fixed value 8 / Tec_ctr fix val 8</b>		
	<b>Access level:</b> 2	<b>Calculated:</b> -	<b>Data type:</b> FloatingPoint32
	<b>Can be changed:</b> T, U	<b>Scaling:</b> PERCENT	<b>Dynamic index:</b> DDS, p0180
	<b>Unit group:</b> 9_1	<b>Unit selection:</b> p0595	<b>Function diagram:</b> 7950
	<b>Min:</b> -200.00 [%]	<b>Max:</b> 200.00 [%]	<b>Factory setting:</b> 80.00 [%]
<b>Description:</b>	Sets the value for fixed value 8 of the technology controller.		
<b>Dependency:</b>	See also: p2220, p2221, p2222, p2223, r2224, r2229		

<b>NOTICE</b>
A BICO interconnection to a parameter that belongs to a drive data set always acts on the effective data set.

<b>p2209[0...n]</b>	<b>CO: Technology controller fixed value 9 / Tec_ctr fix val 9</b>		
	<b>Access level:</b> 2	<b>Calculated:</b> -	<b>Data type:</b> FloatingPoint32
	<b>Can be changed:</b> T, U	<b>Scaling:</b> PERCENT	<b>Dynamic index:</b> DDS, p0180
	<b>Unit group:</b> 9_1	<b>Unit selection:</b> p0595	<b>Function diagram:</b> 7950
	<b>Min:</b> -200.00 [%]	<b>Max:</b> 200.00 [%]	<b>Factory setting:</b> 90.00 [%]
<b>Description:</b>	Sets the value for fixed value 9 of the technology controller.		
<b>Dependency:</b>	See also: p2220, p2221, p2222, p2223, r2224, r2229		

<b>NOTICE</b>
A BICO interconnection to a parameter that belongs to a drive data set always acts on the effective data set.

<b>p2210[0...n]</b>	<b>CO: Technology controller fixed value 10 / Tec_ctr fix val 10</b>		
	<b>Access level:</b> 2	<b>Calculated:</b> -	<b>Data type:</b> FloatingPoint32
	<b>Can be changed:</b> T, U	<b>Scaling:</b> PERCENT	<b>Dynamic index:</b> DDS, p0180
	<b>Unit group:</b> 9_1	<b>Unit selection:</b> p0595	<b>Function diagram:</b> 7950
	<b>Min:</b> -200.00 [%]	<b>Max:</b> 200.00 [%]	<b>Factory setting:</b> 100.00 [%]
<b>Description:</b>	Sets the value for fixed value 10 of the technology controller.		
<b>Dependency:</b>	See also: p2220, p2221, p2222, p2223, r2224, r2229		

<b>NOTICE</b>
A BICO interconnection to a parameter that belongs to a drive data set always acts on the effective data set.

7.3 Parameter list

**p2211[0...n]**      **CO: Technology controller fixed value 11 / Tec\_ctr fix val 11**

<b>Access level:</b> 2	<b>Calculated:</b> -	<b>Data type:</b> FloatingPoint32
<b>Can be changed:</b> T, U	<b>Scaling:</b> PERCENT	<b>Dynamic index:</b> DDS, p0180
<b>Unit group:</b> 9_1	<b>Unit selection:</b> p0595	<b>Function diagram:</b> 7950
<b>Min:</b> -200.00 [%]	<b>Max:</b> 200.00 [%]	<b>Factory setting:</b> 110.00 [%]

**Description:** Sets the value for fixed value 11 of the technology controller.

**Dependency:** See also: p2220, p2221, p2222, p2223, r2224, r2229

<b>NOTICE</b>
A BICO interconnection to a parameter that belongs to a drive data set always acts on the effective data set.

**p2212[0...n]**      **CO: Technology controller fixed value 12 / Tec\_ctr fix val 12**

<b>Access level:</b> 2	<b>Calculated:</b> -	<b>Data type:</b> FloatingPoint32
<b>Can be changed:</b> T, U	<b>Scaling:</b> PERCENT	<b>Dynamic index:</b> DDS, p0180
<b>Unit group:</b> 9_1	<b>Unit selection:</b> p0595	<b>Function diagram:</b> 7950
<b>Min:</b> -200.00 [%]	<b>Max:</b> 200.00 [%]	<b>Factory setting:</b> 120.00 [%]

**Description:** Sets the value for fixed value 12 of the technology controller.

**Dependency:** See also: p2220, p2221, p2222, p2223, r2224, r2229

<b>NOTICE</b>
A BICO interconnection to a parameter that belongs to a drive data set always acts on the effective data set.

**p2213[0...n]**      **CO: Technology controller fixed value 13 / Tec\_ctr fix val 13**

<b>Access level:</b> 2	<b>Calculated:</b> -	<b>Data type:</b> FloatingPoint32
<b>Can be changed:</b> T, U	<b>Scaling:</b> PERCENT	<b>Dynamic index:</b> DDS, p0180
<b>Unit group:</b> 9_1	<b>Unit selection:</b> p0595	<b>Function diagram:</b> 7950
<b>Min:</b> -200.00 [%]	<b>Max:</b> 200.00 [%]	<b>Factory setting:</b> 130.00 [%]

**Description:** Sets the value for fixed value 13 of the technology controller.

**Dependency:** See also: p2220, p2221, p2222, p2223, r2224, r2229

<b>NOTICE</b>
A BICO interconnection to a parameter that belongs to a drive data set always acts on the effective data set.

**p2214[0...n]**      **CO: Technology controller fixed value 14 / Tec\_ctr fix val 14**

<b>Access level:</b> 2	<b>Calculated:</b> -	<b>Data type:</b> FloatingPoint32
<b>Can be changed:</b> T, U	<b>Scaling:</b> PERCENT	<b>Dynamic index:</b> DDS, p0180
<b>Unit group:</b> 9_1	<b>Unit selection:</b> p0595	<b>Function diagram:</b> 7950
<b>Min:</b> -200.00 [%]	<b>Max:</b> 200.00 [%]	<b>Factory setting:</b> 140.00 [%]

**Description:** Sets the value for fixed value 14 of the technology controller.

**Dependency:** See also: p2220, p2221, p2222, p2223, r2224, r2229

<b>NOTICE</b>
A BICO interconnection to a parameter that belongs to a drive data set always acts on the effective data set.

<b>p2215[0...n]</b>	<b>CO: Technology controller fixed value 15 / Tec_ctr fix val 15</b>		
	<b>Access level:</b> 2	<b>Calculated:</b> -	<b>Data type:</b> FloatingPoint32
<b>Description:</b>	<b>Can be changed:</b> T, U	<b>Scaling:</b> PERCENT	<b>Dynamic index:</b> DDS, p0180
	<b>Unit group:</b> 9_1	<b>Unit selection:</b> p0595	<b>Function diagram:</b> 7950
<b>Dependency:</b>	<b>Min:</b>	<b>Max:</b>	<b>Factory setting:</b>
	-200.00 [%]	200.00 [%]	150.00 [%]
<b>NOTICE</b>			
A BICO interconnection to a parameter that belongs to a drive data set always acts on the effective data set.			

<b>p2216[0...n]</b>	<b>Technology controller fixed value selection method / Tec_ctr FixVal sel</b>		
	<b>Access level:</b> 2	<b>Calculated:</b> -	<b>Data type:</b> Integer16
<b>Description:</b>	<b>Can be changed:</b> T	<b>Scaling:</b> -	<b>Dynamic index:</b> DDS, p0180
	<b>Unit group:</b> -	<b>Unit selection:</b> -	<b>Function diagram:</b> 7950, 7951
<b>Value:</b>	<b>Min:</b>	<b>Max:</b>	<b>Factory setting:</b>
	1	2	1
<b>Description:</b> Sets the method to select the fixed setpoints.			
<b>Value:</b> 1: Direct selection			
2: Binary selection			

<b>p2220[0...n]</b>	<b>BI: Technology controller fixed value selection bit 0 / Tec_ctrl sel bit 0</b>		
	<b>Access level:</b> 3	<b>Calculated:</b> -	<b>Data type:</b> Unsigned32 / Binary
<b>Description:</b>	<b>Can be changed:</b> T	<b>Scaling:</b> -	<b>Dynamic index:</b> CDS, p0170
	<b>Unit group:</b> -	<b>Unit selection:</b> -	<b>Function diagram:</b> 7950, 7951
<b>Dependency:</b>	<b>Min:</b>	<b>Max:</b>	<b>Factory setting:</b>
	-	-	0
<b>Description:</b> Sets the signal source to select a fixed value of the technology controller.			
<b>Dependency:</b> See also: p2221, p2222, p2223			

<b>p2221[0...n]</b>	<b>BI: Technology controller fixed value selection bit 1 / Tec_ctrl sel bit 1</b>		
	<b>Access level:</b> 3	<b>Calculated:</b> -	<b>Data type:</b> Unsigned32 / Binary
<b>Description:</b>	<b>Can be changed:</b> T	<b>Scaling:</b> -	<b>Dynamic index:</b> CDS, p0170
	<b>Unit group:</b> -	<b>Unit selection:</b> -	<b>Function diagram:</b> 7950, 7951
<b>Dependency:</b>	<b>Min:</b>	<b>Max:</b>	<b>Factory setting:</b>
	-	-	0
<b>Description:</b> Sets the signal source to select a fixed value of the technology controller.			
<b>Dependency:</b> See also: p2220, p2222, p2223			

<b>p2222[0...n]</b>	<b>BI: Technology controller fixed value selection bit 2 / Tec_ctrl sel bit 2</b>		
	<b>Access level:</b> 3	<b>Calculated:</b> -	<b>Data type:</b> Unsigned32 / Binary
<b>Description:</b>	<b>Can be changed:</b> T	<b>Scaling:</b> -	<b>Dynamic index:</b> CDS, p0170
	<b>Unit group:</b> -	<b>Unit selection:</b> -	<b>Function diagram:</b> 7950, 7951
<b>Dependency:</b>	<b>Min:</b>	<b>Max:</b>	<b>Factory setting:</b>
	-	-	0
<b>Description:</b> Sets the signal source to select a fixed value of the technology controller.			
<b>Dependency:</b> See also: p2220, p2221, p2223			





<b>Dependency:</b>	04 Ramp-function generator always active See also: r2231, p2240	Yes	No	-
<b>Note</b>				
For bit 00:				
0: The setpoint for the motorized potentiometer is not saved and after ON is entered using p2240.				
1: The setpoint for the motorized potentiometer is saved and after ON is entered using r2231. In order to save in a non-volatile fashion, bit 03 should be set to 1.				
For bit 02:				
0: Without initial rounding-off				
1: With initial rounding-off.				
The selected ramp-up/down time is correspondingly exceeded. The initial rounding-off is a sensitive way of specifying small changes (progressive reaction when keys are pressed). The jerk for initial rounding is independent of the ramp-up time and only depends on the selected maximum value (p2237).				
It is calculated as follows:				
$r = 0.0001 \times \max(p2237,  p2238 ) [\%] / 0.13^2 [s^2]$				
The jerk is effective until the maximum acceleration is reached ( $a_{max} = p2237 [\%] / p2247 [s]$ or $a_{max} = p2238 [\%] / p2248 [s]$ ), after which the drive continues to run linearly with constant acceleration.				
The higher the maximum acceleration (the lower that p2247 is), the longer the ramp-up time increases with respect to the set ramp-up time.				
For bit 03:				
0: Non-volatile data save deactivated.				
1. The setpoint for the motorized potentiometer is saved in a non-volatile fashion (for p2230.0 = 1).				
For bit 04:				
When the bit is set, the ramp-function generator is computed independent of the pulse enable. The actual output value of the motorized potentiometer is always in r2250.				

<b>r2231</b>	<b>Technology controller motorized potentiometer setpoint memory / Tec_ctrl mop mem</b>		
	<b>Access level:</b> 3	<b>Calculated:</b> -	<b>Data type:</b> FloatingPoint32
	<b>Can be changed:</b> -	<b>Scaling:</b> -	<b>Dynamic index:</b> -
	<b>Unit group:</b> 9_1	<b>Unit selection:</b> p0595	<b>Function diagram:</b> 7954
	<b>Min:</b> - [%]	<b>Max:</b> - [%]	<b>Factory setting:</b> - [%]
<b>Description:</b>	Displays the setpoint memory for the motorized potentiometer of the technology controller. For p2230.0 = 1, the last setpoint that was saved is entered after ON.		
<b>Dependency:</b>	See also: p2230		

<b>p2235[0...n]</b>	<b>BI: Technology controller motorized potentiometer raise setpoint / Tec_ctrl mop raise</b>		
	<b>Access level:</b> 3	<b>Calculated:</b> -	<b>Data type:</b> Unsigned32 / Binary
	<b>Can be changed:</b> T	<b>Scaling:</b> -	<b>Dynamic index:</b> CDS, p0170
	<b>Unit group:</b> -	<b>Unit selection:</b> -	<b>Function diagram:</b> 7954
	<b>Min:</b> -	<b>Max:</b> -	<b>Factory setting:</b> 0
<b>Description:</b>	Sets the signal source to continually increase the setpoint for the motorized potentiometer of the technology controller. The setpoint change (CO: r2250) depends on the set ramp-up time (p2247) and the duration of the signal that is present (BI: p2235).		
<b>Dependency:</b>	See also: p2236		

<b>p2236[0...n]</b>	<b>BI: Technology controller motorized potentiometer lower setpoint / Tec_ctrl mop lower</b>		
	<b>Access level:</b> 3	<b>Calculated:</b> -	<b>Data type:</b> Unsigned32 / Binary
	<b>Can be changed:</b> T	<b>Scaling:</b> -	<b>Dynamic index:</b> CDS, p0170
	<b>Unit group:</b> -	<b>Unit selection:</b> -	<b>Function diagram:</b> 7954
	<b>Min:</b> -	<b>Max:</b> -	<b>Factory setting:</b> 0
<b>Description:</b>	Sets the signal source to continually reduce the setpoint for the motorized potentiometer of the technology controller. The setpoint change (CO: r2250) depends on the set ramp-down time (p2248) and the duration of the signal that is present (BI: p2236).		
<b>Dependency:</b>	See also: p2235		
<b>p2237[0...n]</b>	<b>Technology controller motorized potentiometer maximum value / Tec_ctrl mop max</b>		
	<b>Access level:</b> 3	<b>Calculated:</b> -	<b>Data type:</b> FloatingPoint32
	<b>Can be changed:</b> T, U	<b>Scaling:</b> -	<b>Dynamic index:</b> DDS, p0180
	<b>Unit group:</b> 9_1	<b>Unit selection:</b> p0595	<b>Function diagram:</b> 7954
	<b>Min:</b> -200.00 [%]	<b>Max:</b> 200.00 [%]	<b>Factory setting:</b> 100.00 [%]
<b>Description:</b>	Sets the maximum value for the motorized potentiometer of the technology controller.		
<b>Dependency:</b>	See also: p2238		
<b>p2238[0...n]</b>	<b>Technology controller motorized potentiometer minimum value / Tec_ctrl mop min</b>		
	<b>Access level:</b> 2	<b>Calculated:</b> -	<b>Data type:</b> FloatingPoint32
	<b>Can be changed:</b> T, U	<b>Scaling:</b> -	<b>Dynamic index:</b> DDS, p0180
	<b>Unit group:</b> 9_1	<b>Unit selection:</b> p0595	<b>Function diagram:</b> 7954
	<b>Min:</b> -200.00 [%]	<b>Max:</b> 200.00 [%]	<b>Factory setting:</b> -100.00 [%]
<b>Description:</b>	Sets the minimum value for the motorized potentiometer of the technology controller.		
<b>Dependency:</b>	See also: p2237		
<b>p2240[0...n]</b>	<b>Technology controller motorized potentiometer starting value / Tec_ctrl mop start</b>		
	<b>Access level:</b> 2	<b>Calculated:</b> -	<b>Data type:</b> FloatingPoint32
	<b>Can be changed:</b> T, U	<b>Scaling:</b> -	<b>Dynamic index:</b> DDS, p0180
	<b>Unit group:</b> 9_1	<b>Unit selection:</b> p0595	<b>Function diagram:</b> 7954
	<b>Min:</b> -200.00 [%]	<b>Max:</b> 200.00 [%]	<b>Factory setting:</b> 0.00 [%]
<b>Description:</b>	Sets the starting value for the motorized potentiometer of the technology controller. For p2230.0 = 0, this setpoint is entered after ON.		
<b>Dependency:</b>	See also: p2230		
<b>r2245</b>	<b>CO: Technology controller mot. potentiometer setpoint before RFG / Tec_ctr mop befRFG</b>		
	<b>Access level:</b> 2	<b>Calculated:</b> -	<b>Data type:</b> FloatingPoint32
	<b>Can be changed:</b> -	<b>Scaling:</b> PERCENT	<b>Dynamic index:</b> -
	<b>Unit group:</b> 9_1	<b>Unit selection:</b> p0595	<b>Function diagram:</b> 7954
	<b>Min:</b> - [%]	<b>Max:</b> - [%]	<b>Factory setting:</b> - [%]
<b>Description:</b>	Sets the effective setpoint in front of the internal motorized potentiometer ramp-function generator of the technology controller.		
<b>Dependency:</b>	See also: r2250		

<b>p2247[0...n]</b>	<b>Technology controller motorized potentiometer ramp-up time / Tec_ctr mop t_r-up</b>		
	<b>Access level:</b> 2	<b>Calculated:</b> -	<b>Data type:</b> FloatingPoint32
	<b>Can be changed:</b> T, U	<b>Scaling:</b> -	<b>Dynamic index:</b> DDS, p0180
	<b>Unit group:</b> -	<b>Unit selection:</b> -	<b>Function diagram:</b> 7954
	<b>Min:</b> 0.0 [s]	<b>Max:</b> 1000.0 [s]	<b>Factory setting:</b> 10.0 [s]
<b>Description:</b>	Sets the ramp-up time for the internal ramp-function generator for the motorized potentiometer of the technology controller.		
<b>Dependency:</b>	See also: p2248		
	<b>Note</b>		
	The time is referred to 100 %.		
	When the initial rounding-off is activated (p2230.2 = 1) the ramp-up is correspondingly extended.		
<b>p2248[0...n]</b>	<b>Technology controller motorized potentiometer ramp-down time / Tec_ctrMop t_rdown</b>		
	<b>Access level:</b> 2	<b>Calculated:</b> -	<b>Data type:</b> FloatingPoint32
	<b>Can be changed:</b> T, U	<b>Scaling:</b> -	<b>Dynamic index:</b> DDS, p0180
	<b>Unit group:</b> -	<b>Unit selection:</b> -	<b>Function diagram:</b> 7954
	<b>Min:</b> 0.0 [s]	<b>Max:</b> 1000.0 [s]	<b>Factory setting:</b> 10.0 [s]
<b>Description:</b>	Sets the ramp-down time for the internal ramp-function generator for the motorized potentiometer of the technology controller.		
<b>Dependency:</b>	See also: p2247		
	<b>Note</b>		
	The time is referred to 100 %.		
	When the initial rounding-off is activated (p2230.2 = 1) the ramp-down is correspondingly extended.		
<b>r2250</b>	<b>CO: Technology controller motorized potentiometer setpoint after RFG / Tec_ctr mop aftRFG</b>		
	<b>Access level:</b> 2	<b>Calculated:</b> -	<b>Data type:</b> FloatingPoint32
	<b>Can be changed:</b> -	<b>Scaling:</b> PERCENT	<b>Dynamic index:</b> -
	<b>Unit group:</b> 9_1	<b>Unit selection:</b> p0595	<b>Function diagram:</b> 7954
	<b>Min:</b> - [%]	<b>Max:</b> - [%]	<b>Factory setting:</b> - [%]
<b>Description:</b>	Displays the effective setpoint after the internal ramp-function generator for the motorized potentiometer of the technology controller.		
<b>Dependency:</b>	See also: r2245		
<b>p2251</b>	<b>Technology controller mode / Tec_ctrl mode</b>		
	<b>Access level:</b> 3	<b>Calculated:</b> -	<b>Data type:</b> Integer16
	<b>Can be changed:</b> T	<b>Scaling:</b> -	<b>Dynamic index:</b> -
	<b>Unit group:</b> -	<b>Unit selection:</b> -	<b>Function diagram:</b> 7958
	<b>Min:</b> 0	<b>Max:</b> 0	<b>Factory setting:</b> 0
<b>Description:</b>	Sets the mode for using the technology controller output.		
<b>Value:</b>	0: Technology controller as main speed setpoint		
<b>Dependency:</b>	p2251 = 0 is only effective if the enable signal of the technology controller is interconnected (p2200 > 0).		

<b>p2252</b>	<b>Technology controller configuration / Tec_ctrl config</b>		
	<b>Access level:</b> 3	<b>Calculated:</b> CALC_MOD_ALL	<b>Data type:</b> Unsigned16
	<b>Can be changed:</b> T, U	<b>Scaling:</b> -	<b>Dynamic index:</b> -
	<b>Unit group:</b> -	<b>Unit selection:</b> -	<b>Function diagram:</b> -
	<b>Min:</b> -	<b>Max:</b> -	<b>Factory setting:</b> 0000 0000 0000 0000 bin

**Description:** Sets the configuration of the technology controller.

<b>Bit field:</b>	<b>Bit</b>	<b>Signal name</b>	<b>1 signal</b>	<b>0 signal</b>	<b>FP</b>
	04	Ramp-up/ramp-down function generator bypass	Deactivated	Activated	-
	05	Integrator active for skip speeds	Yes	No	-
	06	Internal controller limit not displayed	Yes	No	-
	07	Activate Kp adaptation	Yes	No	7958
	08	Activate Tn adaptation	Yes	No	7958

**Dependency:** For bit 04 = 0:  
The setting is only effective when the PID controller is deactivated.

<b>⚠ CAUTION</b>
For bit 04 = 1: The PID controller can oscillate if the ramp-up and ramp-down times of the speed setpoint channel are not taken into account when setting controller parameters p2280 and p2285.

**Note**

For bit 04 = 0:  
The ramp-function generator in the speed setpoint channel is bypassed when the technology controller is operational. As a consequence, ramp times p1120, p1121 are not taken into consideration when configuring the controller.

For bit 04 = 1:  
The ramp-function generator in the speed setpoint channel is not bypassed when the technology controller is operational. As a consequence, the ramp-up and ramp-down times (p1120, p1121) remain effective, and must be taken into account as controlled system variables when setting the PID controller parameters (p2280, p2285). The enable ramps of the PID controller are ensured in this setting by p1120, p1121 as well as rounding functions p1130 and p1131. The ramp-up/ramp-down time of the PID controller limiting p2293 must be set appropriately shorter, as otherwise this has an impact on the speed setpoint channel.

For bit 05 = 0:  
The integral component of the PID controller is held if a skip band or the minimum speed range is passed through in the speed set point channel. This prevents the speed from oscillating between the edges of the skip band.

For bit 05 = 1:  
The setting is only effective if a skip band is no longer active. The integral component of the PID controller is not held in the range of the skip speeds. The skip band is passed through even for small system deviations and low controller gain factors. In so doing, the controller integral time must be selected large enough so that no undesirable speed oscillations occur between the skip band edges. The influence of a minimum speed p1080 on the integration behavior can be reduced by raising the lower PID controller limit to  $p1080 / p2000 * 100\%$ .

For bit 06 = 1:  
In r2349, bit 10 and bit 11 are not displayed when reaching internal limits (e.g. for OFF1/3).

<b>p2253[0...n]</b>	<b>CI: Technology controller setpoint 1 / Tec_ctrl setp 1</b>		
	<b>Access level:</b> 2	<b>Calculated:</b> -	<b>Data type:</b> Unsigned32 / FloatingPoint32
	<b>Can be changed:</b> T, U	<b>Scaling:</b> PERCENT	<b>Dynamic index:</b> CDS, p0170
	<b>Unit group:</b> -	<b>Unit selection:</b> -	<b>Function diagram:</b> 7958
	<b>Min:</b> -	<b>Max:</b> -	<b>Factory setting:</b> 0

**Description:** Sets the signal source for the setpoint 1 of the technology controller.

**Dependency:** See also: p2254, p2255

---

<b>p2254[0...n]</b>	<b>CI: Technology controller setpoint 2 / Tec_ctrl setp 2</b>		
	<b>Access level:</b> 3	<b>Calculated:</b> -	<b>Data type:</b> Unsigned32 / FloatingPoint32
	<b>Can be changed:</b> T, U	<b>Scaling:</b> PERCENT	<b>Dynamic index:</b> CDS, p0170
	<b>Unit group:</b> -	<b>Unit selection:</b> -	<b>Function diagram:</b> 7958
	<b>Min:</b> -	<b>Max:</b> -	<b>Factory setting:</b> 0

**Description:** Sets the signal source for the setpoint 2 of the technology controller.

**Dependency:** See also: p2253, p2256

---

<b>p2255</b>	<b>Technology controller setpoint 1 scaling / Tec_ctrl set1 scal</b>		
	<b>Access level:</b> 3	<b>Calculated:</b> -	<b>Data type:</b> FloatingPoint32
	<b>Can be changed:</b> T, U	<b>Scaling:</b> -	<b>Dynamic index:</b> -
	<b>Unit group:</b> -	<b>Unit selection:</b> -	<b>Function diagram:</b> 7958
	<b>Min:</b> 0.00 [%]	<b>Max:</b> 100.00 [%]	<b>Factory setting:</b> 100.00 [%]

**Description:** Sets the scaling for the setpoint 1 of the technology controller.

**Dependency:** See also: p2253

---

<b>p2256</b>	<b>Technology controller setpoint 2 scaling / Tec_ctrl set2 scal</b>		
	<b>Access level:</b> 3	<b>Calculated:</b> -	<b>Data type:</b> FloatingPoint32
	<b>Can be changed:</b> T, U	<b>Scaling:</b> -	<b>Dynamic index:</b> -
	<b>Unit group:</b> -	<b>Unit selection:</b> -	<b>Function diagram:</b> 7958
	<b>Min:</b> 0.00 [%]	<b>Max:</b> 100.00 [%]	<b>Factory setting:</b> 100.00 [%]

**Description:** Sets the scaling for the setpoint 2 of the technology controller.

**Dependency:** See also: p2254

---

<b>p2257</b>	<b>Technology controller ramp-up time / Tec_ctrl t_ramp-up</b>		
	<b>Access level:</b> 2	<b>Calculated:</b> -	<b>Data type:</b> FloatingPoint32
	<b>Can be changed:</b> T, U	<b>Scaling:</b> -	<b>Dynamic index:</b> -
	<b>Unit group:</b> -	<b>Unit selection:</b> -	<b>Function diagram:</b> 7958
	<b>Min:</b> 0.00 [s]	<b>Max:</b> 650.00 [s]	<b>Factory setting:</b> 1.00 [s]

**Description:** Sets the ramp-up time of the technology controller.

**Dependency:** See also: p2258

**Note**

The ramp-up time is referred to 100 %.

---

<b>p2258</b>	<b>Technology controller ramp-down time / Tec_ctrl t_ramp-dn</b>		
	<b>Access level:</b> 2	<b>Calculated:</b> -	<b>Data type:</b> FloatingPoint32
	<b>Can be changed:</b> T, U	<b>Scaling:</b> -	<b>Dynamic index:</b> -
	<b>Unit group:</b> -	<b>Unit selection:</b> -	<b>Function diagram:</b> 7958
	<b>Min:</b> 0.00 [s]	<b>Max:</b> 650.00 [s]	<b>Factory setting:</b> 1.00 [s]

**Description:** Sets the ramp-down time of the technology controller.

## 7.3 Parameter list

**Dependency:** See also: p2257

**Note**

The ramp-down time is referred to 100 %.

---

**r2260**      **CO: Technology controller setpoint after ramp-function generator / Tec\_ctr set aftRFG**

<b>Access level:</b> 2	<b>Calculated:</b> -	<b>Data type:</b> FloatingPoint32
<b>Can be changed:</b> -	<b>Scaling:</b> PERCENT	<b>Dynamic index:</b> -
<b>Unit group:</b> 9_1	<b>Unit selection:</b> p0595	<b>Function diagram:</b> 7958
<b>Min:</b> - [%]	<b>Max:</b> - [%]	<b>Factory setting:</b> - [%]

**Description:** Sets the setpoint after the ramp-function generator of the technology controller.

---

**p2261**      **Technology controller setpoint filter time constant / Tec\_ctrl set T**

<b>Access level:</b> 3	<b>Calculated:</b> -	<b>Data type:</b> FloatingPoint32
<b>Can be changed:</b> T, U	<b>Scaling:</b> -	<b>Dynamic index:</b> -
<b>Unit group:</b> -	<b>Unit selection:</b> -	<b>Function diagram:</b> 7958
<b>Min:</b> 0.000 [s]	<b>Max:</b> 60.000 [s]	<b>Factory setting:</b> 0.000 [s]

**Description:** Sets the time constant for the setpoint filter (PT1) of the technology controller.

---

**r2262**      **CO: Technology controller setpoint after filter / Tec\_ctr set aftFit**

<b>Access level:</b> 3	<b>Calculated:</b> -	<b>Data type:</b> FloatingPoint32
<b>Can be changed:</b> -	<b>Scaling:</b> PERCENT	<b>Dynamic index:</b> -
<b>Unit group:</b> 9_1	<b>Unit selection:</b> p0595	<b>Function diagram:</b> 7958
<b>Min:</b> - [%]	<b>Max:</b> - [%]	<b>Factory setting:</b> - [%]

**Description:** Display and connector output for the smoothed setpoint after the setpoint filter (PT1) of the technology controller.

---

**p2263**      **Technology controller type / Tec\_ctrl type**

<b>Access level:</b> 3	<b>Calculated:</b> -	<b>Data type:</b> Integer16
<b>Can be changed:</b> T	<b>Scaling:</b> -	<b>Dynamic index:</b> -
<b>Unit group:</b> -	<b>Unit selection:</b> -	<b>Function diagram:</b> 7958
<b>Min:</b> 0	<b>Max:</b> 1	<b>Factory setting:</b> 0

**Description:** Sets the type of technology controller.

**Value:**  
0:            D component in the actual value signal  
1:            D component in system deviation

---

**p2264[0...n]**      **CI: Technology controller actual value / Tec\_ctrl act val**

<b>Access level:</b> 2	<b>Calculated:</b> -	<b>Data type:</b> Unsigned32 / FloatingPoint32
<b>Can be changed:</b> T, U	<b>Scaling:</b> PERCENT	<b>Dynamic index:</b> CDS, p0170
<b>Unit group:</b> -	<b>Unit selection:</b> -	<b>Function diagram:</b> 7958
<b>Min:</b> -	<b>Max:</b> -	<b>Factory setting:</b> 0

**Description:** Sets the signal source for the actual value of the technology controller.

<b>p2265</b>	<b>Technology controller actual value filter time constant / Tec_ctrl act T</b>		
	<b>Access level:</b> 2	<b>Calculated:</b> -	<b>Data type:</b> FloatingPoint32
	<b>Can be changed:</b> T, U	<b>Scaling:</b> -	<b>Dynamic index:</b> -
	<b>Unit group:</b> -	<b>Unit selection:</b> -	<b>Function diagram:</b> 7958
	<b>Min:</b> 0.000 [s]	<b>Max:</b> 60.000 [s]	<b>Factory setting:</b> 0.000 [s]
<b>Description:</b>	Sets the time constant for the actual value filter (PT1) of the technology controller.		

<b>r2266</b>	<b>CO: Technology controller actual value after filter / Tec_ctr act aftFit</b>		
	<b>Access level:</b> 3	<b>Calculated:</b> -	<b>Data type:</b> FloatingPoint32
	<b>Can be changed:</b> -	<b>Scaling:</b> PERCENT	<b>Dynamic index:</b> -
	<b>Unit group:</b> 9_1	<b>Unit selection:</b> p0595	<b>Function diagram:</b> 7958
	<b>Min:</b> - [%]	<b>Max:</b> - [%]	<b>Factory setting:</b> - [%]
<b>Description:</b>	Display and connector output for the smoothed actual value after the filter (PT1) of the technology controller.		

<b>p2267</b>	<b>Technology controller upper limit actual value / Tec_ctrl u_lim act</b>		
	<b>Access level:</b> 3	<b>Calculated:</b> -	<b>Data type:</b> FloatingPoint32
	<b>Can be changed:</b> T, U	<b>Scaling:</b> PERCENT	<b>Dynamic index:</b> -
	<b>Unit group:</b> 9_1	<b>Unit selection:</b> p0595	<b>Function diagram:</b> 7958
	<b>Min:</b> -200.00 [%]	<b>Max:</b> 200.00 [%]	<b>Factory setting:</b> 100.00 [%]
<b>Description:</b>	Sets the upper limit for the actual value signal of the technology controller.		
<b>Dependency:</b>	See also: p2264, p2265, p2271 See also: F07426		

**NOTICE**

If the actual value exceeds this upper limit, this results in fault F07426.

<b>p2268</b>	<b>Technology controller lower limit actual value / Tec_ctrl l_lim act</b>		
	<b>Access level:</b> 3	<b>Calculated:</b> -	<b>Data type:</b> FloatingPoint32
	<b>Can be changed:</b> T, U	<b>Scaling:</b> PERCENT	<b>Dynamic index:</b> -
	<b>Unit group:</b> 9_1	<b>Unit selection:</b> p0595	<b>Function diagram:</b> 7958
	<b>Min:</b> -200.00 [%]	<b>Max:</b> 200.00 [%]	<b>Factory setting:</b> -100.00 [%]
<b>Description:</b>	Sets the lower limit for the actual value signal of the technology controller.		
<b>Dependency:</b>	See also: p2264, p2265, p2271 See also: F07426		

**NOTICE**

If the actual value falls below this lower limit, this results in fault F07426.

<b>p2269</b>	<b>Technology controller gain actual value / Tech_ctrl gain act</b>		
	<b>Access level:</b> 3	<b>Calculated:</b> -	<b>Data type:</b> FloatingPoint32
	<b>Can be changed:</b> T, U	<b>Scaling:</b> -	<b>Dynamic index:</b> -
	<b>Unit group:</b> -	<b>Unit selection:</b> -	<b>Function diagram:</b> 7958
	<b>Min:</b> 0.00 [%]	<b>Max:</b> 500.00 [%]	<b>Factory setting:</b> 100.00 [%]
<b>Description:</b>	Sets the scaling factor for the actual value of the technology controller.		
<b>Dependency:</b>	See also: p2264, p2265, p2267, p2268, p2271		

**Note**

For 100%, the actual value is not changed.

**p2270**      **Technology controller actual value function / Tec\_ctr ActVal fct**

<b>Access level:</b> 3	<b>Calculated:</b> -	<b>Data type:</b> Integer16
<b>Can be changed:</b> T, U	<b>Scaling:</b> -	<b>Dynamic index:</b> -
<b>Unit group:</b> -	<b>Unit selection:</b> -	<b>Function diagram:</b> 7958
<b>Min:</b> 0	<b>Max:</b> 3	<b>Factory setting:</b> 0

**Description:** Setting to use an arithmetic function for the actual value signal of the technology controller.

**Value:**

0:	Output (y) = input (x)
1:	Root function (root from x)
2:	Square function (x * x)
3:	Cube function (x * x * x)

**Dependency:** See also: p2264, p2265, p2267, p2268, p2269, p2271

**p2271**      **Technology controller actual value inversion (sensor type) / Tech\_ctrl act inv**

<b>Access level:</b> 3	<b>Calculated:</b> -	<b>Data type:</b> Integer16
<b>Can be changed:</b> T	<b>Scaling:</b> -	<b>Dynamic index:</b> -
<b>Unit group:</b> -	<b>Unit selection:</b> -	<b>Function diagram:</b> 7958
<b>Min:</b> 0	<b>Max:</b> 1	<b>Factory setting:</b> 0

**Description:** Setting to invert the actual value signal of the technology controller.  
The inversion depends on the sensor type for the actual value signal.

**Value:**

0:	No inversion
1:	Inversion actual value signal

**⚠ CAUTION**

If the actual value inversion is incorrectly selected, then the closed-loop control with the technology controller can become unstable and can oscillate!

**Note**

The correct setting can be determined as follows:

- inhibit the technology controller (p2200 = 0).
- increase the motor speed and in so doing, measure the actual value signal of the technology controller.
- > If the actual value increases as the motor speed increases, then p2271 should be set to 0 (no inversion).
- > If the actual value decreases as the motor speed increases, then p2271 should be set to 1 (the actual value signal is inverted).

**r2272**      **CO: Technology controller actual value scaled / Tech\_ctrl act scal**

<b>Access level:</b> 2	<b>Calculated:</b> -	<b>Data type:</b> FloatingPoint32
<b>Can be changed:</b> -	<b>Scaling:</b> PERCENT	<b>Dynamic index:</b> -
<b>Unit group:</b> 9_1	<b>Unit selection:</b> p0595	<b>Function diagram:</b> 7958
<b>Min:</b> - [%]	<b>Max:</b> - [%]	<b>Factory setting:</b> - [%]

**Description:** Display and connector output for the scaled actual value signal of the technology controller.

**Dependency:** See also: p2264, p2265, r2266, p2267, p2268, p2269, p2270, p2271



<b>r2273</b>	<b>CO: Technology controller system deviation / Tec_ctrl sys_dev</b>		
	<b>Access level:</b> 2	<b>Calculated:</b> -	<b>Data type:</b> FloatingPoint32
<b>Description:</b> <b>Dependency:</b>	<b>Can be changed:</b> -	<b>Scaling:</b> PERCENT	<b>Dynamic index:</b> -
	<b>Unit group:</b> 9_1	<b>Unit selection:</b> p0595	<b>Function diagram:</b> 7958
	<b>Min:</b> - [%]	<b>Max:</b> - [%]	<b>Factory setting:</b> - [%]
	Displays the system deviation between the setpoint and actual value of the technology controller.		
	See also: p2263		

<b>p2274</b>	<b>Technology controller differentiation time constant / Tec_ctrl D comp T</b>		
	<b>Access level:</b> 2	<b>Calculated:</b> -	<b>Data type:</b> FloatingPoint32
<b>Description:</b>	<b>Can be changed:</b> T, U	<b>Scaling:</b> -	<b>Dynamic index:</b> -
	<b>Unit group:</b> -	<b>Unit selection:</b> -	<b>Function diagram:</b> 7958
	<b>Min:</b> 0.000 [s]	<b>Max:</b> 60.000 [s]	<b>Factory setting:</b> 0.000 [s]
	Sets the time constant for the differentiation (D component) of the technology controller.		
	<b>Note</b> p2274 = 0: Differentiation is disabled.		

<b>p2280</b>	<b>Technology controller proportional gain / Tec_ctrl Kp</b>		
	<b>Access level:</b> 2	<b>Calculated:</b> -	<b>Data type:</b> FloatingPoint32
<b>Description:</b>	<b>Can be changed:</b> T, U	<b>Scaling:</b> -	<b>Dynamic index:</b> -
	<b>Unit group:</b> -	<b>Unit selection:</b> -	<b>Function diagram:</b> 7958
	<b>Min:</b> 0.000	<b>Max:</b> 1000.000	<b>Factory setting:</b> 0.500
	Sets the proportional gain (P component) of the technology controller.		
	<b>Note</b> p2280 = 0: The proportional gain is disabled.		

<b>p2285</b>	<b>Technology controller integral time / Tec_ctrl Tn</b>			
	<b>Access level:</b> 2	<b>Calculated:</b> -	<b>Data type:</b> FloatingPoint32	
<b>Description:</b>	<b>Can be changed:</b> T, U	<b>Scaling:</b> -	<b>Dynamic index:</b> -	
	<b>Unit group:</b> -	<b>Unit selection:</b> -	<b>Function diagram:</b> 7958	
	<b>Min:</b> 0.000 [s]	<b>Max:</b> 10000.000 [s]	<b>Factory setting:</b> 10.000 [s]	
	Sets the integral time (I component, integrating time constant) of the technology controller.			
	<table border="1"> <tr> <td><b>NOTICE</b></td> </tr> <tr> <td>The following applies for p2251 = 0: If the output of the technology controller lies within the range of a suppression (skip) bandwidth (p1091 ... p1094, p1101) or below the minimum speed (p1080), the integral component of the controller is held so that the controller temporarily works as a P controller. This is necessary in order to prevent the controller from behaving in an unstable manner, as the ramp-function generator switches to the parameterized up and down ramps (p1120, p1121) at the same time in order to avoid setpoint steps. This state can be exited or avoided by changing the controller setpoint or by using the start speed (= minimum speed).</td> </tr> </table>			<b>NOTICE</b>
<b>NOTICE</b>				
The following applies for p2251 = 0: If the output of the technology controller lies within the range of a suppression (skip) bandwidth (p1091 ... p1094, p1101) or below the minimum speed (p1080), the integral component of the controller is held so that the controller temporarily works as a P controller. This is necessary in order to prevent the controller from behaving in an unstable manner, as the ramp-function generator switches to the parameterized up and down ramps (p1120, p1121) at the same time in order to avoid setpoint steps. This state can be exited or avoided by changing the controller setpoint or by using the start speed (= minimum speed).				
<b>Note</b> When the controller output reaches the limit, the I component of the controller is held. p2285 = 0: The integral time is disabled and the I component of the controller is reset.				

7.3 Parameter list

---

**p2286[0...n]**      **BI: Hold technology controller integrator / Tec\_ctr integ hold**

<b>Access level:</b> 3	<b>Calculated:</b> -	<b>Data type:</b> Unsigned32 / Binary
<b>Can be changed:</b> T	<b>Scaling:</b> -	<b>Dynamic index:</b> CDS, p0170
<b>Unit group:</b> -	<b>Unit selection:</b> -	<b>Function diagram:</b> 7958
<b>Min:</b>	<b>Max:</b>	<b>Factory setting:</b>
-	-	56.13

**Description:**      Sets the signal source to hold the integrator for the technology controller.

---

**p2289[0...n]**      **CI: Technology controller precontrol signal / Tec\_ctr prectr\_sig**

<b>Access level:</b> 3	<b>Calculated:</b> -	<b>Data type:</b> Unsigned32 / FloatingPoint32
<b>Can be changed:</b> T, U	<b>Scaling:</b> PERCENT	<b>Dynamic index:</b> CDS, p0170
<b>Unit group:</b> -	<b>Unit selection:</b> -	<b>Function diagram:</b> 7958
<b>Min:</b>	<b>Max:</b>	<b>Factory setting:</b>
-	-	0

**Description:**      Sets the signal source for the precontrol signal of the technology controller.

---

**p2290[0...n]**      **BI: Technology controller limiting enable / Tec\_ctrl lim enab**

<b>Access level:</b> 2	<b>Calculated:</b> -	<b>Data type:</b> Unsigned32 / Binary
<b>Can be changed:</b> T	<b>Scaling:</b> -	<b>Dynamic index:</b> CDS, p0170
<b>Unit group:</b> -	<b>Unit selection:</b> -	<b>Function diagram:</b> 7958
<b>Min:</b>	<b>Max:</b>	<b>Factory setting:</b>
-	-	1

**Description:**      Sets the signal source to enable the technology controller output.  
 The technology controller output is enabled with a 1 signal.  
 The technology controller output is held with a 0 signal.

---

**p2291**              **CO: Technology controller maximum limiting / Tec\_ctrl max\_lim**

<b>Access level:</b> 3	<b>Calculated:</b> -	<b>Data type:</b> FloatingPoint32
<b>Can be changed:</b> T, U	<b>Scaling:</b> PERCENT	<b>Dynamic index:</b> -
<b>Unit group:</b> -	<b>Unit selection:</b> -	<b>Function diagram:</b> 7958
<b>Min:</b>	<b>Max:</b>	<b>Factory setting:</b>
-200.00 [%]	200.00 [%]	100.00 [%]

**Description:**      Sets the maximum limit of the technology controller.  
**Dependency:**      See also: p2292

 <b>CAUTION</b>
The maximum limit must always be greater than the minimum limit (p2291 > p2292).

---

**p2292**              **CO: Technology controller minimum limiting / Tec\_ctrl min\_lim**

<b>Access level:</b> 3	<b>Calculated:</b> -	<b>Data type:</b> FloatingPoint32
<b>Can be changed:</b> T, U	<b>Scaling:</b> PERCENT	<b>Dynamic index:</b> -
<b>Unit group:</b> -	<b>Unit selection:</b> -	<b>Function diagram:</b> 7958
<b>Min:</b>	<b>Max:</b>	<b>Factory setting:</b>
-200.00 [%]	200.00 [%]	0.00 [%]

**Description:**      Sets the minimum limit of the technology controller.  
**Dependency:**      See also: p2291

 <b>CAUTION</b>
The maximum limit must always be greater than the minimum limit (p2291 > p2292).

<b>p2293</b>	<b>Technology controller ramp-up/ramp-down time / Tec_ctr t_RU/RD</b>	<b>Access level:</b> 3 <b>Can be changed:</b> T, U <b>Unit group:</b> - <b>Min:</b> 0.00 [s]	<b>Calculated:</b> - <b>Scaling:</b> - <b>Unit selection:</b> - <b>Max:</b> 100.00 [s]	<b>Data type:</b> FloatingPoint32 <b>Dynamic index:</b> - <b>Function diagram:</b> 7958 <b>Factory setting:</b> 1.00 [s]
<b>Description:</b>	Sets the ramping time for the output signal of the technology controller.			
<b>Dependency:</b>	See also: p2291, p2292			
	<b>Note</b> The time refers to the set maximum and minimum limits (p2291, p2292).			
<b>r2294</b>	<b>CO: Technology controller output signal / Tec_ctrl outp_sig</b>	<b>Access level:</b> 2 <b>Can be changed:</b> - <b>Unit group:</b> - <b>Min:</b> - [%]	<b>Calculated:</b> - <b>Scaling:</b> PERCENT <b>Unit selection:</b> - <b>Max:</b> - [%]	<b>Data type:</b> FloatingPoint32 <b>Dynamic index:</b> - <b>Function diagram:</b> 7958 <b>Factory setting:</b> - [%]
<b>Description:</b>	Display and connector output for the output signal of the technology controller.			
<b>Dependency:</b>	See also: p2295			
<b>p2295</b>	<b>CO: Technology controller output scaling / Tec_ctrl outp scal</b>	<b>Access level:</b> 3 <b>Can be changed:</b> T, U <b>Unit group:</b> - <b>Min:</b> -100.00 [%]	<b>Calculated:</b> - <b>Scaling:</b> PERCENT <b>Unit selection:</b> - <b>Max:</b> 100.00 [%]	<b>Data type:</b> FloatingPoint32 <b>Dynamic index:</b> - <b>Function diagram:</b> 7958 <b>Factory setting:</b> 100.00 [%]
<b>Description:</b>	Sets the scaling for the output signal of the technology controller.			
<b>p2296[0...n]</b>	<b>CI: Technology controller output scaling / Tec_ctrl outp scal</b>	<b>Access level:</b> 3 <b>Can be changed:</b> T, U <b>Unit group:</b> - <b>Min:</b> -	<b>Calculated:</b> - <b>Scaling:</b> PERCENT <b>Unit selection:</b> - <b>Max:</b> -	<b>Data type:</b> Unsigned32 / FloatingPoint32 <b>Dynamic index:</b> CDS, p0170 <b>Function diagram:</b> 7958 <b>Factory setting:</b> 2295[0]
<b>Description:</b>	Sets the signal source for the scaling value of the technology controller.			
<b>Dependency:</b>	See also: p2295			
<b>p2297[0...n]</b>	<b>CI: Technology controller maximum limit signal source / Tec_ctrMaxLimS_src</b>	<b>Access level:</b> 3 <b>Can be changed:</b> T, U <b>Unit group:</b> - <b>Min:</b> -	<b>Calculated:</b> - <b>Scaling:</b> PERCENT <b>Unit selection:</b> - <b>Max:</b> -	<b>Data type:</b> Unsigned32 / FloatingPoint32 <b>Dynamic index:</b> CDS, p0170 <b>Function diagram:</b> 7958 <b>Factory setting:</b> 1084[0]
<b>Description:</b>	Sets the signal source for the maximum limiting of the technology controller.			
<b>Dependency:</b>	See also: p2291			

**Note**

In order that the output of the technology controller does not exceed the maximum speed limit, its upper limit p2297 should be connected to the actual maximum speed r1084.

<b>p2298[0...n]</b>	<b>CI: Technology controller minimum limit signal source / Tec_ctrl min_l s_s</b>		
	<b>Access level:</b> 3	<b>Calculated:</b> -	<b>Data type:</b> Unsigned32 / FloatingPoint32
	<b>Can be changed:</b> T, U	<b>Scaling:</b> PERCENT	<b>Dynamic index:</b> CDS, p0170
	<b>Unit group:</b> -	<b>Unit selection:</b> -	<b>Function diagram:</b> 7958
	<b>Min:</b> -	<b>Max:</b> -	<b>Factory setting:</b> 2292[0]
<b>Description:</b>	Sets the signal source for the minimum limiting of the technology controller.		
<b>Dependency:</b>	See also: p2292		

**Note**

If the technology controller is rotated in a negative direction in mode p2251 = 0, its lower limit p2298 should be connected to the actual minimum speed r1087.

<b>p2299[0...n]</b>	<b>CI: Technology controller limit offset / Tech_ctrl lim offs</b>		
	<b>Access level:</b> 3	<b>Calculated:</b> -	<b>Data type:</b> Unsigned32 / FloatingPoint32
	<b>Can be changed:</b> T, U	<b>Scaling:</b> PERCENT	<b>Dynamic index:</b> CDS, p0170
	<b>Unit group:</b> -	<b>Unit selection:</b> -	<b>Function diagram:</b> 7958
	<b>Min:</b> -	<b>Max:</b> -	<b>Factory setting:</b> 0
<b>Description:</b>	Sets the signal source for the offset of the output limiting of the technology controller.		

<b>p2302</b>	<b>Technology controller output signal starting value / Tec_ctr start val</b>		
	<b>Access level:</b> 3	<b>Calculated:</b> -	<b>Data type:</b> FloatingPoint32
	<b>Can be changed:</b> T, U	<b>Scaling:</b> -	<b>Dynamic index:</b> -
	<b>Unit group:</b> -	<b>Unit selection:</b> -	<b>Function diagram:</b> 7958
	<b>Min:</b> 0.00 [%]	<b>Max:</b> 200.00 [%]	<b>Factory setting:</b> 0.00 [%]
<b>Description:</b>	Sets the start value for the output of the technology controller. If the drive is switched on and the technology controller is already enabled (see p2200, r0056.3), then its output signal r2294 first goes to the start value p2302, before the controller starts to operate.		
<b>Dependency:</b>	The starting value is only effective in the mode "technology controller as main speed setpoint" (p2251 = 0). If the technology controller is first enabled when the drive is switched on, a start speed remains ineffective, and the controller output starts with the actual setpoint speed of the ramp-function generator.		

**Note**

If the technology controller operates on the speed/setpoint channel (p2251 = 0), then the starting value is interpreted as the starting speed and when operation is enabled, is connected to the output of the technology controller (r2294).  
If fault F07426 "technology controller actual value limited" occurs while ramping up to the starting value and if the associated reaction has been set to "NONE" (see p2100, p2101), the starting value is kept as the speed setpoint instead of a switch to closed-loop control operation.

<b>p2306</b>	<b>Technology controller system deviation inversion / Tec_ctr SysDev inv</b>		
	<b>Access level:</b> 3	<b>Calculated:</b> -	<b>Data type:</b> Integer16
	<b>Can be changed:</b> T	<b>Scaling:</b> -	<b>Dynamic index:</b> -
	<b>Unit group:</b> -	<b>Unit selection:</b> -	<b>Function diagram:</b> 7958
	<b>Min:</b> 0	<b>Max:</b> 1	<b>Factory setting:</b> 0
<b>Description:</b>	Setting to invert the system deviation of the technology controller. The setting depends on the type of control loop.		
<b>Value:</b>	0: No inversion 1: Inversion		

**⚠ CAUTION**

If the actual value inversion is incorrectly selected, then the closed-loop control with the technology controller can become unstable and can oscillate!

**Note**

The correct setting can be determined as follows:

- inhibit the technology controller (p2200 = 0).
- increase the motor speed and in so doing, measure the actual value signal (of the technology controller).
- if the actual value increases with increasing motor speed, then the inversion should be switched out.
- if the actual value decreases with increasing motor speed, then the inversion should be set.

If value = 0:

The drive reduces the output speed when the actual value rises (e.g. for heating fans, intake pump, compressor).

If value = 1:

The drive increases the output speed when the actual value increases (e.g. for cooling fans, discharge pumps).

<b>p2310</b>	<b>CI: Technology controller Kp adaptation input value signal source / Kp adapt inp s_src</b>		
	<b>Access level:</b> 2	<b>Calculated:</b> -	<b>Data type:</b> Unsigned32 / FloatingPoint32
	<b>Can be changed:</b> T	<b>Scaling:</b> PERCENT	<b>Dynamic index:</b> -
	<b>Unit group:</b> -	<b>Unit selection:</b> -	<b>Function diagram:</b> 7959
	<b>Min:</b> -	<b>Max:</b> -	<b>Factory setting:</b> 0
<b>Description:</b>	Sets the signal source for the input value of the adaptation of proportional gain Kp for the technology controller.		
<b>Dependency:</b>	See also: p2252, p2311, p2312, p2313, p2314, p2315, r2316		

<b>p2311</b>	<b>Technology controller Kp adaptation lower value / Kp adapt lower val</b>		
	<b>Access level:</b> 2	<b>Calculated:</b> -	<b>Data type:</b> FloatingPoint32
	<b>Can be changed:</b> T, U	<b>Scaling:</b> -	<b>Dynamic index:</b> -
	<b>Unit group:</b> -	<b>Unit selection:</b> -	<b>Function diagram:</b> 7959
	<b>Min:</b> 0.000	<b>Max:</b> 1000.000	<b>Factory setting:</b> 1.000
<b>Description:</b>	Sets the lower value for the adaptation of proportional gain Kp for the technology controller.		
<b>Dependency:</b>	See also: p2310, p2312, p2313, p2314, p2315, r2316		

**⚠ CAUTION**

The upper value must be set higher than the lower value (p2312 > p2311).

**Note**

Kp adaptation is activated with p2252.7 = 1.

7.3 Parameter list

**p2312**      **Technology controller Kp adaptation upper value / Kp adapt upper val**

<b>Access level:</b> 2	<b>Calculated:</b> -	<b>Data type:</b> FloatingPoint32
<b>Can be changed:</b> T, U	<b>Scaling:</b> -	<b>Dynamic index:</b> -
<b>Unit group:</b> -	<b>Unit selection:</b> -	<b>Function diagram:</b> 7959
<b>Min:</b> 0.000	<b>Max:</b> 1000.000	<b>Factory setting:</b> 10.000

**Description:** Sets the upper value for the adaptation of proportional gain Kp for the technology controller.

**Dependency:** See also: p2310, p2311, p2313, p2314, p2315, r2316

 <b>CAUTION</b>
The upper value must be set higher than the lower value (p2312 > p2311).

**Note**  
Kp adaptation is activated with p2252.7 = 1.

**p2313**      **Technology controller Kp adaptation lower starting point / Kp adapt lower pt**

<b>Access level:</b> 2	<b>Calculated:</b> -	<b>Data type:</b> FloatingPoint32
<b>Can be changed:</b> T, U	<b>Scaling:</b> PERCENT	<b>Dynamic index:</b> -
<b>Unit group:</b> -	<b>Unit selection:</b> -	<b>Function diagram:</b> 7959
<b>Min:</b> 0.00 [%]	<b>Max:</b> 400.00 [%]	<b>Factory setting:</b> 0.00 [%]

**Description:** Sets the lower starting point for the adaptation of proportional gain Kp for the technology controller.

**Dependency:** See also: p2310, p2311, p2312, p2314, p2315, r2316

 <b>CAUTION</b>
The upper starting point must be set higher than the lower starting point (p2314 > p2313).

**Note**  
Kp adaptation is activated with p2252.7 = 1.

**p2314**      **Technology controller Kp adaptation upper starting point / Kp adapt upper pt**

<b>Access level:</b> 2	<b>Calculated:</b> -	<b>Data type:</b> FloatingPoint32
<b>Can be changed:</b> T, U	<b>Scaling:</b> PERCENT	<b>Dynamic index:</b> -
<b>Unit group:</b> -	<b>Unit selection:</b> -	<b>Function diagram:</b> 7959
<b>Min:</b> 0.00 [%]	<b>Max:</b> 400.00 [%]	<b>Factory setting:</b> 100.00 [%]

**Description:** Sets the upper activation point for the adaptation of proportional gain Kp for the technology controller.

**Dependency:** See also: p2310, p2311, p2312, p2313, p2315, r2316

 <b>CAUTION</b>
The upper starting point must be set higher than the lower starting point (p2314 > p2313).

**Note**  
Kp adaptation is activated with p2252.7 = 1.

**p2315**      **CI: Technology controller Kp adaptation scaling signal source / Kp adapt scal s\_s**

<b>Access level:</b> 3	<b>Calculated:</b> -	<b>Data type:</b> Unsigned32 / FloatingPoint32
<b>Can be changed:</b> T	<b>Scaling:</b> PERCENT	<b>Dynamic index:</b> -
<b>Unit group:</b> -	<b>Unit selection:</b> -	<b>Function diagram:</b> 7959
<b>Min:</b> -	<b>Max:</b> -	<b>Factory setting:</b> 1

**Description:** Sets the signal source to scale the results of the adaptation of the proportional gain Kp for the technology controller.

**Dependency:** See also: p2310, p2311, p2312, p2313, p2314, r2316

**Note**

Kp adaptation is activated with p2252.7 = 1.

**r2316****CO: Technology controller, Kp adaptation output / Kp adapt outp****Access level:** 2**Calculated:** -**Data type:** FloatingPoint32**Can be changed:** -**Scaling:** -**Dynamic index:** -**Unit group:** -**Unit selection:** -**Function diagram:** 7959**Min:****Max:****Factory setting:**

-

-

-

**Description:**

Display and connector output for the output signal of the adaption of proportional gain Kp for the technology controller.

**Dependency:**

See also: p2252, p2310, p2311, p2312, p2313, p2314, p2315

**p2317****CI: Technology controller Tn adaptation input value signal source / Tn adapt inp s\_src****Access level:** 2**Calculated:** -**Data type:** Unsigned32 /  
FloatingPoint32**Can be changed:** T**Scaling:** PERCENT**Dynamic index:** -**Unit group:** -**Unit selection:** -**Function diagram:** 7959**Min:****Max:****Factory setting:**

-

-

0

**Description:**

Sets the signal source for the input value of the adaptation of integral time Tn for the technology controller.

**Dependency:**

See also: p2252, p2318, p2319, p2320, p2321, r2322

**Note**

Tn adaptation is activated with p2252.8 = 1.

**p2318****Technology controller Tn adaptation lower value / Tn adapt lower val****Access level:** 2**Calculated:** -**Data type:** FloatingPoint32**Can be changed:** T, U**Scaling:** -**Dynamic index:** -**Unit group:** -**Unit selection:** -**Function diagram:** 7959**Min:****Max:****Factory setting:**

0.000 [s]

60.000 [s]

3.000 [s]

**Description:**

Sets the lower value for the adaptation of integral time Tn for the technology controller.

**Dependency:**

See also: p2317, p2319, p2320, p2321, r2322

**⚠ CAUTION**

The upper value must be set higher than the lower value (p2319 > p2318).

**Note**

Tn adaptation is activated with p2252.8 = 1.

**p2319****Technology controller Tn adaptation upper value / Tn adapt upper val****Access level:** 2**Calculated:** -**Data type:** FloatingPoint32**Can be changed:** T, U**Scaling:** -**Dynamic index:** -**Unit group:** -**Unit selection:** -**Function diagram:** 7959**Min:****Max:****Factory setting:**

0.000 [s]

60.000 [s]

10.000 [s]

**Description:**

Sets the upper value for the adaptation of integral time Tn for the technology controller.

**Dependency:**

See also: p2317, p2318, p2320, p2321, r2322

**⚠ CAUTION**

The upper value must be set higher than the lower value (p2319 > p2318).

**Note**

Tn adaptation is activated with p2252.8 = 1.

**p2320****Technology controller Tn adaptation lower starting point / Tn adapt lower pt**

<b>Access level:</b> 2	<b>Calculated:</b> -	<b>Data type:</b> FloatingPoint32
<b>Can be changed:</b> T, U	<b>Scaling:</b> PERCENT	<b>Dynamic index:</b> -
<b>Unit group:</b> -	<b>Unit selection:</b> -	<b>Function diagram:</b> 7959
<b>Min:</b> 0.00 [%]	<b>Max:</b> 400.00 [%]	<b>Factory setting:</b> 0.00 [%]

**Description:**

Sets the lower activation point for the adaptation of integral time Tn for the technology controller.

**Dependency:**

See also: p2317, p2318, p2319, p2321, r2322

**⚠ CAUTION**

The upper starting point must be set higher than the lower starting point (p2321 > p2320).

**Note**

Tn adaptation is activated with p2252.8 = 1.

**p2321****Technology controller Tn adaptation upper starting point / Tn adapt upper pt**

<b>Access level:</b> 2	<b>Calculated:</b> -	<b>Data type:</b> FloatingPoint32
<b>Can be changed:</b> T	<b>Scaling:</b> PERCENT	<b>Dynamic index:</b> -
<b>Unit group:</b> -	<b>Unit selection:</b> -	<b>Function diagram:</b> 7959
<b>Min:</b> 0.00 [%]	<b>Max:</b> 400.00 [%]	<b>Factory setting:</b> 100.00 [%]

**Description:**

Sets the upper activation point for the adaptation of integral time Tn for the technology controller.

**Dependency:**

See also: p2317, p2318, p2319, p2320, r2322

**⚠ CAUTION**

The upper starting point must be set higher than the lower starting point (p2321 > p2320).

**Note**

Tn adaptation is activated with p2252.8 = 1.

**r2322****CO: Technology controller Tn adaptation output / Tn adapt output**

<b>Access level:</b> 2	<b>Calculated:</b> -	<b>Data type:</b> FloatingPoint32
<b>Can be changed:</b> -	<b>Scaling:</b> -	<b>Dynamic index:</b> -
<b>Unit group:</b> -	<b>Unit selection:</b> -	<b>Function diagram:</b> 7959
<b>Min:</b> - [s]	<b>Max:</b> - [s]	<b>Factory setting:</b> - [s]

**Description:**

Display and connector output for the output signal of the adaption of integral time Tn for the technology controller.

**Dependency:**

See also: p2252, p2317, p2318, p2319, p2320, p2321

**Note**

Tn adaptation is activated with p2252.8 = 1.

**p2339****Techn. controller threshold value f. I comp. hold for skip speed / Tec\_ctrl thr\_skip**

<b>Access level:</b> 3	<b>Calculated:</b> -	<b>Data type:</b> FloatingPoint32
<b>Can be changed:</b> T, U	<b>Scaling:</b> PERCENT	<b>Dynamic index:</b> -
<b>Unit group:</b> 9_1	<b>Unit selection:</b> p0595	<b>Function diagram:</b> -
<b>Min:</b> 0.00 [%]	<b>Max:</b> 200.00 [%]	<b>Factory setting:</b> 2.00 [%]



**Description:** Sets the threshold value for the system deviation of the technology controller, which controls holding the controller integral component in the range of the skip speeds of the ramp-function generator.

**Recommendation:** To avoid speed setpoint steps in the range of the skip speeds, we recommend setting p2252 bit 4 = 1 (ramp-function generator bypass deactivated).

**Dependency:** The parameter has no effect for p2252 bit 5 = 1 (integrator hold deactivated).  
See also: r2273

**Note**

Only p2251 = 0:

If the output signal of the technology controller reaches a skip band in the speed setpoint channel, then the integral component of the controller is held, if at the same time, the system deviation is lower than the threshold value set here. By holding the integral component, it can be avoided that the controller oscillates in the range of the skip bands.

---

**r2344**      **CO: Technology controller last speed setpoint (smoothed) / Tec\_ctrl n\_setp\_sm**

<b>Access level:</b> 3	<b>Calculated:</b> -	<b>Data type:</b> FloatingPoint32
<b>Can be changed:</b> -	<b>Scaling:</b> PERCENT	<b>Dynamic index:</b> -
<b>Unit group:</b> -	<b>Unit selection:</b> -	<b>Function diagram:</b> 7958
<b>Min:</b> - [%]	<b>Max:</b> - [%]	<b>Factory setting:</b> - [%]

**Description:** Displays the smoothed speed setpoint of the technology controller prior to switching to operation with fault response (see p2345).

**Dependency:** See also: p2345

---

**Note**  
Smoothing time = 10 s

---

**p2345**      **Technology controller fault response / Tech\_ctrl fit resp**

<b>Access level:</b> 3	<b>Calculated:</b> -	<b>Data type:</b> Integer16
<b>Can be changed:</b> T, U	<b>Scaling:</b> -	<b>Dynamic index:</b> -
<b>Unit group:</b> -	<b>Unit selection:</b> -	<b>Function diagram:</b> 7958
<b>Min:</b> 0	<b>Max:</b> 2	<b>Factory setting:</b> 0

**Description:** Sets the response of the technology controller to the occurrence of fault F07426 (technology controller actual value limited).  
The fault response is executed if status bit 8 or 9 in the technology controller status word r2349 is set. If both status bits are zero, a switch back to technology controller operation will follow.

**Value:**

0:	Function inhibited
1:	On fault: Changeover to r2344 (or p2302)
2:	On fault: Changeover to p2215

**Dependency:** The parameterized fault response is only effective if the technology controller mode is set to p2251 = 0 (technology controller as main setpoint).  
See also: p2267, p2268, r2344  
See also: F07426

**NOTICE**

Dependent upon the application, the changing over of the setpoint when fault F07426 occurs can lead to the fault condition disappearing and the re-activation of the technology controller. This can repeat itself and cause limit oscillations. In this case, a different fault response or a different fixed setpoint 15 for the fault response p2345 = 2 should be selected.



**Note**

P2350 = 1

This is the Ziegler-Nichols standard tuning (ZN tuning). In this case, it should involve a response to a step.

P2350 = 2

For this tuning, a low overshoot is obtained (O/S). However, it should be faster than option 1.

P2350 = 3

For this tuning, a low or no overshoot is obtained. However, it is not as fast as option 2.

P2350 = 4

For this tuning, only values P and I are changed, and it should involve a dampened response.

Which option should be selected depends on the particular application. It can be generally stated that option 1 manifests a good response. However, if a faster response is required, then option 2 should be selected.

If no overshoot is desirable, then option 3 should be the preferred choice.

Option 4 should be selected for cases in which no D component is required.

The tuning technique is identical for all options.

Only the P, I and D values are calculated differently.

This parameter is set to zero after automatic tuning has been completed.

<b>p2354</b>	<b>PID autotuning monitoring time / PID tuning t_monit</b>		
	<b>Access level:</b> 3	<b>Calculated:</b> -	<b>Data type:</b> Unsigned16
	<b>Can be changed:</b> T	<b>Scaling:</b> -	<b>Dynamic index:</b> -
	<b>Unit group:</b> -	<b>Unit selection:</b> -	<b>Function diagram:</b> -
	<b>Min:</b> 60 [s]	<b>Max:</b> 65000 [s]	<b>Factory setting:</b> 240 [s]
<b>Description:</b>	Sets the monitoring time for the PID autotuning This time is started after activating PID autotuning (p2350). If, within this time, the control loop is not excited, then the automatic setting is canceled and an appropriate fault is output.		
<b>Dependency:</b>	See also: p2350 See also: F07445		
<b>p2355</b>	<b>PID autotuning offset / PID autotun.offset</b>		
	<b>Access level:</b> 3	<b>Calculated:</b> -	<b>Data type:</b> FloatingPoint32
	<b>Can be changed:</b> T	<b>Scaling:</b> -	<b>Dynamic index:</b> -
	<b>Unit group:</b> -	<b>Unit selection:</b> -	<b>Function diagram:</b> -
	<b>Min:</b> 0 [%]	<b>Max:</b> 20 [%]	<b>Factory setting:</b> 5 [%]
<b>Description:</b>	This parameter is used to set the excitation type of the PID control loop to be used.		
<b>p2370[0...n]</b>	<b>Closed-loop cascade control enable / Csc_ctrl enab</b>		
	<b>Access level:</b> 3	<b>Calculated:</b> -	<b>Data type:</b> Integer16
	<b>Can be changed:</b> T	<b>Scaling:</b> -	<b>Dynamic index:</b> DDS, p0180
	<b>Unit group:</b> -	<b>Unit selection:</b> -	<b>Function diagram:</b> -
	<b>Min:</b> 0	<b>Max:</b> 1	<b>Factory setting:</b> 0
<b>Description:</b>	Sets the signal source to switch in/switch out the closed-loop cascade control function. 1 signal: The function is switched in.		
<b>Value:</b>	0: Closed-loop cascade control inhibited 1: Closed-loop cascade control enabled		

**Note**

The technology controller must be activated (p2200) and configured (p2251 = 0) in order to use the function. Negative speed setpoints should be excluded.

**p2371****Closed-loop cascade control configuration / Csc\_ctrl config**

<b>Access level:</b> 3	<b>Calculated:</b> -	<b>Data type:</b> Integer16
<b>Can be changed:</b> T	<b>Scaling:</b> -	<b>Dynamic index:</b> -
<b>Unit group:</b> -	<b>Unit selection:</b> -	<b>Function diagram:</b> -
<b>Min:</b> 0	<b>Max:</b> 8	<b>Factory setting:</b> 0

**Description:**

Parameter for configuring the connection and disconnection of external motors to and from the line voltage.

Connecting external motors to the line voltage enables up to three additional drives to be controlled by the technology controller in addition to the main drive. The complete system, therefore, comprises one closed-loop-controlled main drive and up to three other drives, which can be controlled via contactors or motor starters. The contactors or motor starters are switched by the converter's digital outputs (see also r2379).

Switching-in motor:

If the main drive is operated at maximum speed and the deviation at the technology controller input increases further, the control will in addition connect external motors M1 through M3 to the line voltage. At the same time, the main drive is ramped down to the closed-loop cascade control switch-in/switch-out speed (p2378) via the down ramp, so that the total output power can be kept as constant as possible. During this time the technology controller is switched off.

Switching-off the motor:

If the main drive is operated at minimum speed and the deviation at the technology controller input decreases further, the control will disconnect external motors M1 through M3 from the line voltage. At the same time, the main drive is ramped up to the closed-loop cascade control switch-in/switch-out speed (p2378) via the up ramp, so that the total output power can be kept as constant as possible.

**Value:**

0:	Closed-loop cascade control inhibited
1:	M1 = 1X
2:	M1 = 1X, M2 = 1X
3:	M1 = 1X, M2 = 2X
4:	M1 = 1X, M2 = 1X, M3 = 1X
5:	M1 = 1X, M2 = 1X, M3 = 2X
6:	M1 = 1X, M2 = 2X, M3 = 2X
7:	M1 = 1X, M2 = 1X, M3 = 3X
8:	M1 = 1X, M2 = 2X, M3 = 3X

**Dependency:**

See also: p2372

**Note**

Selecting 2X means that a motor is switched in with twice the power (as opposed to 1X, which equates to the motor power at the converter).

**p2372****Closed-loop cascade control mode motor selection / Csc\_ctrl mode**

<b>Access level:</b> 3	<b>Calculated:</b> -	<b>Data type:</b> Integer16
<b>Can be changed:</b> T	<b>Scaling:</b> -	<b>Dynamic index:</b> -
<b>Unit group:</b> -	<b>Unit selection:</b> -	<b>Function diagram:</b> -
<b>Min:</b> 0	<b>Max:</b> 3	<b>Factory setting:</b> 0

**Description:**

Parameter for selecting the control mode for switching-in and switching-out external motors.

Selection 2 and 3 support selection options for automatically interchanging the motors, which are connected to the line supply.

**Value:**

0:	Fixed sequence
1:	Closed-loop cascade control after absolute operating hours
2:	Automatic replacement after continuous operating hours

3: Automatic replacement after absolute operating hours

**Note**

For p2372 = 0:

Motor selection for switching-in/switching-out follows a fixed sequence and is dependent on the closed-loop cascade control configuration (p2371).

For p2372 = 1:

Motor selection for switching-in/switching-out is derived from the operating hours counter p2380. When switching-in, the motor with the least operating hours is connected. When switching-out, the motor with the most operating hours is disconnected.

For p2372 = 2:

Motor selection for switching-in/switching-out is derived from the operating hours counter p2380. When switching-in, the motor with the least operating hours is connected. When switching-out, the motor with the most operating hours is disconnected.

In addition, those motors which have been in operation continuously for longer than the time set in p2381 are interchanged automatically.

If p2371 = 4 (selection of three identical motors), the switch is only performed between two motors, if the required input power of one single external motor is sufficient for the actual operating point.

For p2372 = 3:

Motor selection for switching-in/switching-out is derived from the operating hours counter p2380. When switching-in, the motor with the least operating hours is connected. When switching-out, the motor with the most operating hours is disconnected.

In addition, those motors which have been in operation for a total time longer than that set in p2382 are interchanged automatically.

For p2372 = 2, 3:

This automatic interchange (autochange) is only possible if the designated motor is not in operation. If all motors are in operation, the interchange will not be possible and alarm A07427 appears.

Autochange mode is only possible if p2371 = 2, 4 (motors of the same size).

<b>p2373</b>	<b>Closed-loop cascade control switch-in threshold / Csc_ctrl sw-in thr</b>		
	<b>Access level:</b> 3	<b>Calculated:</b> -	<b>Data type:</b> FloatingPoint32
	<b>Can be changed:</b> T, U	<b>Scaling:</b> PERCENT	<b>Dynamic index:</b> -
	<b>Unit group:</b> 9_1	<b>Unit selection:</b> p0595	<b>Function diagram:</b> -
	<b>Min:</b> 0.0 [%]	<b>Max:</b> 200.0 [%]	<b>Factory setting:</b> 20.0 [%]
<b>Description:</b>	Threshold value for the delayed switching-in or non-delayed switching-out of external motors connected to the line. Motor switching-in is activated if the maximum speed is reached and the wait time in p2374 has expired.		
<b>Dependency:</b>	See also: p2374		

<b>p2374</b>	<b>Closed-loop cascade control switch-in delay / Csc_ctrl t_in_del</b>		
	<b>Access level:</b> 3	<b>Calculated:</b> -	<b>Data type:</b> Unsigned16
	<b>Can be changed:</b> T, U	<b>Scaling:</b> -	<b>Dynamic index:</b> -
	<b>Unit group:</b> -	<b>Unit selection:</b> -	<b>Function diagram:</b> -
	<b>Min:</b> 0 [s]	<b>Max:</b> 650 [s]	<b>Factory setting:</b> 30 [s]
<b>Description:</b>	Additional delay time for connecting external motors to the line voltage after the system deviation of the technology controller has exceeded the threshold value p2373 and the motor has reached the maximum speed.		
<b>Dependency:</b>	See also: p2373		

**Note**

If the deviation at the technology controller input exceeds the overcontrol threshold p2376, the delay time is bypassed.

<b>p2375</b>	<b>Closed-loop cascade control switch-out delay / Csc_ctrl t_out_del</b>		
	<b>Access level:</b> 3	<b>Calculated:</b> -	<b>Data type:</b> Unsigned16
	<b>Can be changed:</b> T, U	<b>Scaling:</b> -	<b>Dynamic index:</b> -
	<b>Unit group:</b> -	<b>Unit selection:</b> -	<b>Function diagram:</b> -
	<b>Min:</b> 0 [s]	<b>Max:</b> 650 [s]	<b>Factory setting:</b> 30 [s]
<b>Description:</b>	Additional delay time for the disconnection of external motors from the line after the system deviation of the technology controller has exceeded the threshold p2373 and the motor has reached the minimum speed p1080.		
<b>Dependency:</b>	See also: p2373, p2376		
	<b>Note</b> If the deviation at the technology controller input exceeds the overcontrol threshold -p2376, the delay time is bypassed.		
<b>p2376</b>	<b>Closed-loop cascade control overcontrol threshold / Csc_ctr ovctr_thr</b>		
	<b>Access level:</b> 3	<b>Calculated:</b> -	<b>Data type:</b> FloatingPoint32
	<b>Can be changed:</b> T, U	<b>Scaling:</b> PERCENT	<b>Dynamic index:</b> -
	<b>Unit group:</b> 9_1	<b>Unit selection:</b> p0595	<b>Function diagram:</b> -
	<b>Min:</b> 0.0 [%]	<b>Max:</b> 200.0 [%]	<b>Factory setting:</b> 25.0 [%]
<b>Description:</b>	Threshold value for instantaneous switching-in or switching-out external motors.		
	<b>Note</b> If the maximum speed is reached and the deviation at the technology controller input exceeds the overcontrol threshold p2376 at the same time, the delay time p2374 is bypassed and the motor is immediately switched-in (connected). If the minimum speed is reached and the deviation at the technology controller input exceeds the overcontrol threshold -p2376 at the same time, the delay time p2375 is bypassed and the motor is immediately switched-out (disconnected).		
<b>p2377</b>	<b>Closed-loop cascade control interlocking time / Csc_ctrl t_interl</b>		
	<b>Access level:</b> 3	<b>Calculated:</b> -	<b>Data type:</b> Unsigned16
	<b>Can be changed:</b> T, U	<b>Scaling:</b> -	<b>Dynamic index:</b> -
	<b>Unit group:</b> -	<b>Unit selection:</b> -	<b>Function diagram:</b> -
	<b>Min:</b> 0 [s]	<b>Max:</b> 650 [s]	<b>Factory setting:</b> 0 [s]
<b>Description:</b>	Interlocking time during which, following the connection or disconnection of an external motor, no further motors are connected or disconnected using the closed-loop cascade control. This avoids duplicate switching operations.		
<b>p2378</b>	<b>Closed-loop cascade control switch-in/switch-out speed / Csc_ctrl n_in/out</b>		
	<b>Access level:</b> 3	<b>Calculated:</b> -	<b>Data type:</b> FloatingPoint32
	<b>Can be changed:</b> T	<b>Scaling:</b> -	<b>Dynamic index:</b> -
	<b>Unit group:</b> -	<b>Unit selection:</b> -	<b>Function diagram:</b> -
	<b>Min:</b> 0.0 [%]	<b>Max:</b> 100.0 [%]	<b>Factory setting:</b> 50.0 [%]
<b>Description:</b>	Sets the speed for the main drive, which is approached directly after an external motor has been connected or disconnected. The parameter value refers to the maximum speed (p1082).		



<b>p2383</b>	<b>Closed-loop cascade control switch-out sequence / Csc_ctr sw-out seq</b>		
	<b>Access level:</b> 3	<b>Calculated:</b> -	<b>Data type:</b> Integer16
	<b>Can be changed:</b> T	<b>Scaling:</b> -	<b>Dynamic index:</b> -
	<b>Unit group:</b> -	<b>Unit selection:</b> -	<b>Function diagram:</b> -
	<b>Min:</b> 0	<b>Max:</b> 1	<b>Factory setting:</b> 0
<b>Description:</b>	<p>Selection of the response used to stop the motors when the OFF command is sent.</p> <p>For p2383 = 1:  OFF1 disconnects the external motors from the line in the order 3 - 2 - 1. The time set in p2387 is applied as a delay time between the disconnection of each motor. The main motor is only switched off if all the external motors have already been switched off.</p> <p>In the case of OFF2 and OFF3, the external motors and the main motor are switched off immediately with the OFF command (same behavior as with p2383 = 0).</p>		
<b>Value:</b>	0: Normal stop 1: Sequential stop		
<p><b>⚠ CAUTION</b></p> <p>If p2383 = 1 and the OFF1 command is pending, the main motor will not be stopped until all external motors have been disconnected and time p2387 has elapsed. By switching off the external motors the main motor can be accelerated again.</p>			
<b>p2384</b>	<b>Closed-loop cascade control motor switch-on delay / Csc_ctr t_del_on</b>		
	<b>Access level:</b> 3	<b>Calculated:</b> -	<b>Data type:</b> FloatingPoint32
	<b>Can be changed:</b> T, U	<b>Scaling:</b> -	<b>Dynamic index:</b> -
	<b>Unit group:</b> -	<b>Unit selection:</b> -	<b>Function diagram:</b> -
	<b>Min:</b> 0.000 [s]	<b>Max:</b> 999.000 [s]	<b>Factory setting:</b> 0.000 [s]
<b>Description:</b>	<p>Delay time once the switch-in conditions have been met until the external motor is switched on.</p> <p>The activation of the corresponding status bit (r2379) for controlling the contactors or the motor starter is delayed by this time, while the main motor speed already decreases down to the switch-in speed (p2378).</p>		
<b>p2385</b>	<b>Closed-loop cascade control holding time switch-in speed / Csc_ctr t_hld_n_in</b>		
	<b>Access level:</b> 3	<b>Calculated:</b> -	<b>Data type:</b> FloatingPoint32
	<b>Can be changed:</b> T, U	<b>Scaling:</b> -	<b>Dynamic index:</b> -
	<b>Unit group:</b> -	<b>Unit selection:</b> -	<b>Function diagram:</b> -
	<b>Min:</b> 0.000 [s]	<b>Max:</b> 999.000 [s]	<b>Factory setting:</b> 0.000 [s]
<b>Description:</b>	<p>Time during which the switch-in speed (see p2378) of the main motor is maintained after an external motor has been switched-in and the main motor has been decelerated to the switch-in speed.</p>		
<b>p2386</b>	<b>Closed-loop cascade control motor switch-off delay / Csc_ctrl t_del_off</b>		
	<b>Access level:</b> 3	<b>Calculated:</b> -	<b>Data type:</b> FloatingPoint32
	<b>Can be changed:</b> T, U	<b>Scaling:</b> -	<b>Dynamic index:</b> -
	<b>Unit group:</b> -	<b>Unit selection:</b> -	<b>Function diagram:</b> -
	<b>Min:</b> 0.000 [s]	<b>Max:</b> 999.000 [s]	<b>Factory setting:</b> 0.000 [s]
<b>Description:</b>	<p>Delay time once the switch-out conditions have been met until the external motor is switched off.</p> <p>The resetting of the corresponding status bit (r2379) for controlling the contactors or the motor starter is delayed by this time, while the main motor ramps up to the switch-out speed (p2378).</p>		



<b>p2387</b>	<b>Closed-loop cascade control holding time switch-out speed / CscCtr t_hld n_out</b>		
	<b>Access level:</b> 3	<b>Calculated:</b> -	<b>Data type:</b> FloatingPoint32
	<b>Can be changed:</b> T, U	<b>Scaling:</b> -	<b>Dynamic index:</b> -
	<b>Unit group:</b> -	<b>Unit selection:</b> -	<b>Function diagram:</b> -
	<b>Min:</b> 0.000 [s]	<b>Max:</b> 999.000 [s]	<b>Factory setting:</b> 0.000 [s]
<b>Description:</b>	Time during which the switch-out speed (see p2378) of the main motor is maintained after an external motor has been switched-out and the main motor has been accelerated to the switch-out speed.		
<b>p2390[0...n]</b>	<b>Speed start of hibernation mode / Hib mode n_start</b>		
	<b>Access level:</b> 3	<b>Calculated:</b> CALC_MOD_LIM_REF	<b>Data type:</b> FloatingPoint32
	<b>Can be changed:</b> T, U	<b>Scaling:</b> p2000	<b>Dynamic index:</b> DDS, p0180
	<b>Unit group:</b> 3_1	<b>Unit selection:</b> p0505	<b>Function diagram:</b> 7038
	<b>Min:</b> 0.000 [rpm]	<b>Max:</b> 21000.000 [rpm]	<b>Factory setting:</b> 0.000 [rpm]
<b>Description:</b>	Sets the speed for the start of the "hibernation mode" function. The total speed of this activation threshold is the sum of the minimum speed p1080 and p2390. If the speed setpoint undershoots this start speed, the delay time in p2391 is started. If the restart threshold is no longer reached before the delay time expires, the hibernation mode boost speed p2395 is impressed for the time period p2394 and then the motor is brought to a standstill via the down ramp of the setpoint channel. The drive is switched off (hibernation mode active). The drive is automatically switched on again as soon as the speed setpoint exceeds the restart threshold.		
	<b>Note</b> The speed at which the hibernation mode is started is set to 4 % of the nominal speed when commissioning is completed.		
<b>p2391[0...n]</b>	<b>Hibernation mode delay time / Hib mode t_delay</b>		
	<b>Access level:</b> 3	<b>Calculated:</b> -	<b>Data type:</b> FloatingPoint32
	<b>Can be changed:</b> T, U	<b>Scaling:</b> -	<b>Dynamic index:</b> DDS, p0180
	<b>Unit group:</b> -	<b>Unit selection:</b> -	<b>Function diagram:</b> 7038
	<b>Min:</b> 0 [s]	<b>Max:</b> 3599 [s]	<b>Factory setting:</b> 120 [s]
<b>Description:</b>	Sets the delay time for the "hibernation mode" function. To ensure that the drive can be shut down (pulse inhibit), a restart condition must not occur during this time.		
<b>Dependency:</b>	See also: p2390, p2392, p2393		
<b>p2392</b>	<b>Hibernation mode restart value with technology controller / Hib start w/ tec</b>		
	<b>Access level:</b> 3	<b>Calculated:</b> CALC_MOD_LIM_REF	<b>Data type:</b> FloatingPoint32
	<b>Can be changed:</b> T, U	<b>Scaling:</b> -	<b>Dynamic index:</b> -
	<b>Unit group:</b> 9_1	<b>Unit selection:</b> p0595	<b>Function diagram:</b> 7038
	<b>Min:</b> 0.000 [%]	<b>Max:</b> 200.000 [%]	<b>Factory setting:</b> 0.000 [%]
<b>Description:</b>	Sets the motor restart time with the "Hibernation mode" function. If the hibernation mode function is active, the technology controller continues to operate and supplies a speed setpoint to the setpoint channel. Since the drive is deactivated, there is no system deviation at the input of the technology controller. As soon as this exceeds the restart value p2392, the drive is automatically switched on and the speed is controlled to $1.05 * (p1080 + p2390)$ via the up ramp of the setpoint channel.		
	<b>Note</b> The restart value is set to 5 % when commissioning is completed.		

<b>p2393[0...n]</b>	<b>Hibernation mode restart speed relative w/o techn controller / Hib start w/o tec</b>		
	<b>Access level:</b> 3	<b>Calculated:</b> CALC_MOD_LIM_REF	<b>Data type:</b> FloatingPoint32
	<b>Can be changed:</b> T, U	<b>Scaling:</b> -	<b>Dynamic index:</b> DDS, p0180
	<b>Unit group:</b> 3_1	<b>Unit selection:</b> p0505	<b>Function diagram:</b> 7038
	<b>Min:</b> 0.000 [rpm]	<b>Max:</b> 21000.000 [rpm]	<b>Factory setting:</b> 0.000 [rpm]
<b>Description:</b>	Sets the starting speed to restart the motor for the "hibernation mode" function. When the hibernation mode is active, a speed setpoint is still supplied to the setpoint channel. If the setpoint increases again and in so doing exceeds the restart speed, the drive is automatically switched on and the speed setpoint is controlled to p1080 + p2390 + p2393 via the up ramp of the setpoint channel. The restart speed is the sum of the minimum speed p1080, the hibernation start speed p2390 and the relative restart speed p2393.		
<b>Dependency:</b>	See also: p1080		
	<b>Note</b> The parameter is set to 6 % of the nominal speed when commissioning is exited.		
<b>p2394[0...n]</b>	<b>Hibernation mode boost time period / Hib mode t_boost</b>		
	<b>Access level:</b> 3	<b>Calculated:</b> -	<b>Data type:</b> FloatingPoint32
	<b>Can be changed:</b> T, U	<b>Scaling:</b> -	<b>Dynamic index:</b> DDS, p0180
	<b>Unit group:</b> -	<b>Unit selection:</b> -	<b>Function diagram:</b> 7038
	<b>Min:</b> 0 [s]	<b>Max:</b> 3599 [s]	<b>Factory setting:</b> 0 [s]
<b>Description:</b>	Sets the boost time period for the "hibernation mode" function. Before the drive is finally switched off (hibernation mode), the setpoint speed is moved to the boost speed p2395 for the time set in p2394. Depending on the application, this allows the hibernation intervals to be extended (in time).		
	<div style="border: 1px solid black; padding: 5px;"> <p><b>⚠ CAUTION</b></p> <p>The controller is not operational while the boost speed is being impressed. As a result, for example, for pump applications, it must be ensured that the tank does not overflow as a result of the additional boost. For compressors, it must be ensured that the boost speed does not result in an overpressure condition.</p> </div>		
	<b>Note</b> For p2394 = 0 s, the following applies: The boost speed is not used.		
<b>p2395[0...n]</b>	<b>Hibernation mode boost speed / Hib mode n_boost</b>		
	<b>Access level:</b> 3	<b>Calculated:</b> -	<b>Data type:</b> FloatingPoint32
	<b>Can be changed:</b> T, U	<b>Scaling:</b> p2000	<b>Dynamic index:</b> DDS, p0180
	<b>Unit group:</b> 3_1	<b>Unit selection:</b> p0505	<b>Function diagram:</b> 7038
	<b>Min:</b> 0.000 [rpm]	<b>Max:</b> 21000.000 [rpm]	<b>Factory setting:</b> 0.000 [rpm]
<b>Description:</b>	Sets the boost speed for the "hibernation mode" function. The motor is accelerated to the hibernation mode boost speed p2395 for the hibernation mode boost time period p2394 before it is brought to a standstill via the down ramp of the setpoint channel (p1121) and subsequently switched off (pulse inhibit).		
<b>Dependency:</b>	See also: p2394		
	<div style="border: 1px solid black; padding: 5px;"> <p><b>⚠ CAUTION</b></p> <p>The controller is not operational while the boost speed is being impressed. As a result, for example, for pump applications, it must be ensured that the tank does not overflow as a result of the additional boost. For compressors, it must be ensured that the boost speed does not result in an overpressure condition.</p> </div>		

<b>p2396[0...n]</b>	<b>Hibernation mode max. shutdown time / Hib t_off max</b>		
	<b>Access level:</b> 3	<b>Calculated:</b> -	<b>Data type:</b> FloatingPoint32
	<b>Can be changed:</b> T, U	<b>Scaling:</b> -	<b>Dynamic index:</b> DDS, p0180
	<b>Unit group:</b> -	<b>Unit selection:</b> -	<b>Function diagram:</b> 7038
	<b>Min:</b> 0 [s]	<b>Max:</b> 863999 [s]	<b>Factory setting:</b> 0 [s]
<b>Description:</b>	Sets the maximum shutdown time for the "Hibernation mode" function. If the drive is in the hibernation mode (pulse inhibit) then it is switched on again at the latest after the maximum switch-off time has expired. If the restart conditions are fulfilled earlier, then the drive is correspondingly switched on earlier.		
<b>⚠ DANGER</b>			
The drive automatically powers itself up at the latest after the maximum switch-off time has expired.			
<b>⚠ CAUTION</b>			
Once the maximum shutdown time has expired, the drive switches itself on automatically and accelerates to the start speed. The technology controller only becomes effective again when this speed is reached (for p2398 = 1). Depending on the application, for instance for pumps, it should be ensured that as a result of cyclic starts the tank does not overflow or for compressors, an overpressure condition does not occur.			
<b>Note</b> Automatic restart once the maximum OFF time has elapsed is deactivated by setting p2396 = 0 s.			
<b>r2397[0...1]</b>	<b>CO: Hibernation mode output speed actual / Hib n_outp act</b>		
	<b>Access level:</b> 3	<b>Calculated:</b> -	<b>Data type:</b> FloatingPoint32
	<b>Can be changed:</b> -	<b>Scaling:</b> p2000	<b>Dynamic index:</b> -
	<b>Unit group:</b> 3_1	<b>Unit selection:</b> p0505	<b>Function diagram:</b> 7038
	<b>Min:</b> - [rpm]	<b>Max:</b> - [rpm]	<b>Factory setting:</b> - [rpm]
<b>Description:</b>	Display and connector output for the actual output speed for the "hibernation mode" function.		
<b>Note</b> Zero is displayed if the boost or starting speed is not active.			
<b>p2398</b>	<b>Hibernation mode operating type / Hib mode op_type</b>		
	<b>Access level:</b> 3	<b>Calculated:</b> -	<b>Data type:</b> Integer16
	<b>Can be changed:</b> T	<b>Scaling:</b> -	<b>Dynamic index:</b> -
	<b>Unit group:</b> -	<b>Unit selection:</b> -	<b>Function diagram:</b> 7038
	<b>Min:</b> 0	<b>Max:</b> 1	<b>Factory setting:</b> 0
<b>Description:</b>	Sets the operating mode for the "Hibernation mode" function.		
<b>Value:</b>	0: Hibernation mode inhibited 1: Hibernation mode activated		
<b>Dependency:</b>	See also: p2200, p2251 See also: A07325		
<b>⚠ CAUTION</b>			
When the "hibernation mode" function is active, the motor can start again automatically.			

7.3 Parameter list

**Note**

When the "hibernation mode" function (p2398 = 1) is activated, its behavior is defined as to whether the technology controller is additionally switched in (closed-loop) or switched out (open-loop).

The technology controller is enabled via binector input p2200 and its mode is set in p2251.

p2200 = 0, p2251 = 0:

Hibernation mode operates without technology controller (open-loop)

p2200 = 1, p2251 = 0:

Hibernation mode operates with technology controller (closed-loop)

r2399.0...8

**CO/BO: Hibernation mode status words / Hib ZSW**

**Access level:** 3

**Calculated:** -

**Data type:** Unsigned32

**Can be changed:** -

**Scaling:** -

**Dynamic index:** -

**Unit group:** -

**Unit selection:** -

**Function diagram:** 7038

**Min:**

**Max:**

**Factory setting:**

-

-

-

**Description:**

Display and BICO output for the status word of the "hibernation mode" function.

**Bit field:**

Bit	Signal name	1 signal	0 signal	FP
00	Hibernation mode enabled (p2398 <> 0)	Yes	No	-
01	Hibernation mode active	Yes	No	-
02	Hibernation mode delay active	Yes	No	-
03	Hibernation boost active	Yes	No	-
04	Hibernation mode motor switched off	Yes	No	-
05	Hibernation mode switched off cyclic restart active	Yes	No	-
06	Hibernation motor motor restarts	Yes	No	-
07	Hibernation mode supplies total setpoint for ramp-fct generator	Yes	No	-
08	Hibernation mode bypasses ramp-fct generator in setpoint channel	Yes	No	-

**Dependency:**

See also: p2398

See also: A07325

p2900[0...n]

**CO: Fixed value 1 [%] / Fixed value 1 [%]**

**Access level:** 3

**Calculated:** -

**Data type:** FloatingPoint32

**Can be changed:** T, U

**Scaling:** PERCENT

**Dynamic index:** DDS, p0180

**Unit group:** -

**Unit selection:** -

**Function diagram:** 1021

**Min:**

**Max:**

**Factory setting:**

-10000.00 [%]

10000.00 [%]

0.00 [%]

**Description:**

Setting and connector output for a fixed percentage value.

**Dependency:**

See also: p2901, r2902, p2930

**NOTICE**

A BICO interconnection to a parameter that belongs to a drive data set always acts on the effective data set.

**Note**

The value can be used to interconnect a scaling function (e.g. scaling the main setpoint).

<b>p2901[0...n]</b>	<b>CO: Fixed value 2 [%] / Fixed value 2 [%]</b>		
	<b>Access level:</b> 3	<b>Calculated:</b> -	<b>Data type:</b> FloatingPoint32
	<b>Can be changed:</b> T, U	<b>Scaling:</b> PERCENT	<b>Dynamic index:</b> DDS, p0180
	<b>Unit group:</b> -	<b>Unit selection:</b> -	<b>Function diagram:</b> 1021
	<b>Min:</b> -10000.00 [%]	<b>Max:</b> 10000.00 [%]	<b>Factory setting:</b> 0.00 [%]
<b>Description:</b>	Setting and connector output for a fixed percentage value.		
<b>Dependency:</b>	See also: p2900, p2930		

**NOTICE**

A BICO interconnection to a parameter that belongs to a drive data set always acts on the effective data set.

**Note**

The value can be used to interconnect a scaling function (e.g. scaling of the supplementary setpoint)

<b>r2902[0...14]</b>	<b>CO: Fixed values [%] / Fixed values [%]</b>		
	<b>Access level:</b> 3	<b>Calculated:</b> -	<b>Data type:</b> FloatingPoint32
	<b>Can be changed:</b> -	<b>Scaling:</b> PERCENT	<b>Dynamic index:</b> -
	<b>Unit group:</b> -	<b>Unit selection:</b> -	<b>Function diagram:</b> 1021
	<b>Min:</b> - [%]	<b>Max:</b> - [%]	<b>Factory setting:</b> - [%]
<b>Description:</b>	Display and connector output for frequently used percentage values.		
<b>Index:</b>	[0] = Fixed value +0 % [1] = Fixed value +5 % [2] = Fixed value +10 % [3] = Fixed value +20 % [4] = Fixed value +50 % [5] = Fixed value +100 % [6] = Fixed value +150 % [7] = Fixed value +200 % [8] = Fixed value -5 % [9] = Fixed value -10 % [10] = Fixed value -20 % [11] = Fixed value -50 % [12] = Fixed value -100 % [13] = Fixed value -150 % [14] = Fixed value -200 %		
<b>Dependency:</b>	See also: p2900, p2901, p2930		

**Note**

The signal sources can, for example, be used to interconnect scalings.

<b>p2930[0...n]</b>	<b>CO: Fixed value M [Nm] / Fixed value M [Nm]</b>		
	<b>Access level:</b> 3	<b>Calculated:</b> -	<b>Data type:</b> FloatingPoint32
	<b>Can be changed:</b> T, U	<b>Scaling:</b> p2003	<b>Dynamic index:</b> DDS, p0180
	<b>Unit group:</b> -	<b>Unit selection:</b> -	<b>Function diagram:</b> 1021
	<b>Min:</b> -100000.00 [Nm]	<b>Max:</b> 100000.00 [Nm]	<b>Factory setting:</b> 0.00 [Nm]
<b>Description:</b>	Setting and connector output for a fixed torque value.		
<b>Dependency:</b>	See also: p2900, p2901, r2902		

7.3 Parameter list

<b>NOTICE</b>
A BICO interconnection to a parameter that belongs to a drive data set always acts on the effective data set.

**Note**  
The value can, for example, be used to interconnect a supplementary torque.

<b>r2969[0...6]</b>	<b>Flux model value display / Psi_mod val displ</b>		
	<b>Access level:</b> 3	<b>Calculated:</b> -	<b>Data type:</b> FloatingPoint32
	<b>Can be changed:</b> -	<b>Scaling:</b> -	<b>Dynamic index:</b> -
	<b>Unit group:</b> -	<b>Unit selection:</b> -	<b>Function diagram:</b> -
	<b>Min:</b>	<b>Max:</b>	<b>Factory setting:</b>
	-	-	-

**Description:** Displays the values of the direct access flux model for the synchronous reluctance motor (RESM) for diagnostic purposes.

Valid values are only displayed when the pulses are inhibited.

For index 0:

Displays the entered direct axis current id in Arms:

For index 1, 2, 3:

Displays the saturation curves of the direct axis flux psid(id, iq):

- r2969[1]: flux in Vsrms with respect to the direct axis current for iq = 0

- r2969[2]: flux in Vsrms with respect to the direct axis current for iq = 0.5 \* p2950

- r2969[3]: flux in Vsrms with respect to the direct axis current for iq = p2950

For index 4, 5, 6:

Displays the relative error of the current inversion (id(psid, iq) - id) / p2950:

- r2969[4]: error with respect to direct axis current for iq = 0

- r2969[5]: error with respect to direct axis current for iq = 0.5 \* p2950

- r2969[6]: error with respect to direct axis current for iq = p2950

**Index:**

[0]	= d-current
[1]	= d-flux iq0
[2]	= d-flux iq1
[3]	= d-flux iq2
[4]	= d-current error iq0
[5]	= d-current error iq1
[6]	= d-current error iq2

**Note**  
RESM: reluctance synchronous motor (synchronous reluctance motor)

<b>p3110</b>	<b>External fault 3 switch-on delay / Ext fault 3 t_on</b>		
	<b>Access level:</b> 3	<b>Calculated:</b> -	<b>Data type:</b> Unsigned16
	<b>Can be changed:</b> T, U	<b>Scaling:</b> -	<b>Dynamic index:</b> -
	<b>Unit group:</b> -	<b>Unit selection:</b> -	<b>Function diagram:</b> 2546
	<b>Min:</b>	<b>Max:</b>	<b>Factory setting:</b>
	0 [ms]	1000 [ms]	0 [ms]

**Description:** Sets the delay time for external fault 3.

**Dependency:** See also: p2108, p3111, p3112

See also: F07862

---

<b>p3111[0...n]</b>	<b>BI: External fault 3 enable / Ext fault 3 enab</b>		
	<b>Access level:</b> 3	<b>Calculated:</b> -	<b>Data type:</b> Unsigned32 / Binary
	<b>Can be changed:</b> T, U	<b>Scaling:</b> -	<b>Dynamic index:</b> CDS, p0170
	<b>Unit group:</b> -	<b>Unit selection:</b> -	<b>Function diagram:</b> -
	<b>Min:</b>	<b>Max:</b>	<b>Factory setting:</b>
	-	-	1

**Description:** Sets the signal source for the enable signal of external fault 3.  
External fault 3 is initiated by the following AND logic operation:

- BI: p2108 negated
- BI: p3111
- BI: p3112 negated

**Dependency:** See also: p2108, p3110, p3112  
See also: F07862

---

<b>p3112[0...n]</b>	<b>BI: External fault 3 enable negated / Ext fit 3 enab neg</b>		
	<b>Access level:</b> 3	<b>Calculated:</b> -	<b>Data type:</b> Unsigned32 / Binary
	<b>Can be changed:</b> T, U	<b>Scaling:</b> -	<b>Dynamic index:</b> CDS, p0170
	<b>Unit group:</b> -	<b>Unit selection:</b> -	<b>Function diagram:</b> -
	<b>Min:</b>	<b>Max:</b>	<b>Factory setting:</b>
	-	-	0

**Description:** Sets the signal source for the negated enable signal of external fault 3.  
External fault 3 is initiated by the following AND logic operation:

- BI: p2108 negated
- BI: p3111
- BI: p3112 negated

**Dependency:** See also: p2108, p3110, p3111  
See also: F07862

---

<b>r3113.0...15</b>	<b>CO/BO: NAMUR message bit bar / NAMUR bit bar</b>		
	<b>Access level:</b> 3	<b>Calculated:</b> -	<b>Data type:</b> Unsigned16
	<b>Can be changed:</b> -	<b>Scaling:</b> -	<b>Dynamic index:</b> -
	<b>Unit group:</b> -	<b>Unit selection:</b> -	<b>Function diagram:</b> -
	<b>Min:</b>	<b>Max:</b>	<b>Factory setting:</b>
	-	-	-

**Description:** Display and BICO output for the status of the NAMUR message bit bar.  
The faults and alarms are assigned to the appropriate signaling/message classes and influence a specific message bit.

<b>Bit field:</b>	<b>Bit</b>	<b>Signal name</b>	<b>1 signal</b>	<b>0 signal</b>	<b>FP</b>
	00	Fault converter information electronics/software error	Yes	No	-
	01	Network fault	Yes	No	-
	02	DC link overvoltage	Yes	No	-
	03	Fault drive converter power electronics	Yes	No	-
	04	Drive converter overtemperature	Yes	No	-
	05	Ground fault	Yes	No	-
	06	Motor overload	Yes	No	-
	07	Bus error	Yes	No	-
	08	External safety-relevant shutdown	Yes	No	-
	10	Error communication internal	Yes	No	-
	11	Fault infeed	Yes	No	-

7.3 Parameter list

15	Other faults	Yes	No	-
----	--------------	-----	----	---

**Note**

For bit 00:  
Hardware or software malfunction was identified. Carry out a POWER ON of the component involved. If it occurs again, contact Technical Support.

For bit 01:  
A line supply fault has occurred (phase failure, voltage level, ...). Check the line supply / fuses. Check the supply voltage. Check the wiring.

For bit 02:  
The DC link voltage has assumed an inadmissibly high value. Check the dimensioning of the system (line supply, reactor, voltages). Check the infeed settings.

For bit 03:  
An inadmissible operating state of the power electronics was identified (overcurrent, overtemperature, IGBT failure, ...). Check that the permissible load cycles are maintained. Check the ambient temperatures (fan).

For bit 04:  
The temperature in the component has exceeded the highest permissible limit. Check the ambient temperature / control cabinet cooling.

For bit 05:  
A ground fault / inter-phase short-circuit was detected in the power cables or in the motor windings. Check the power cables (connection). Check the motor.

For bit 06:  
The motor was operated outside the permissible limits (temperature, current, torque, ...). Check the load cycles and limits that have been set. Check the ambient temperature / motor cooling.

For bit 07:  
The communication to the higher-level control system (internal coupling, PROFIBUS, PROFINET, ...) is faulted or interrupted. Check the state of the higher-level control system. Check the communication connection/wiring. Check the bus configuration / clock cycles.

For bit 08:  
A safety operation monitoring function (Safety) has detected an error.

For bit 09:  
When evaluating the encoder signals (track signals, zero marks, absolute values, ...) an illegal signal state was detected. Check the encoder / state of the encoder signals. Observe the maximum frequencies.

For bit 10:  
The internal communication between the SINAMICS components is faulted or interrupted. Check the DRIVE-CLiQ wiring. Ensure an EMC-compliant design. Observe the maximum permissible quantity structure / clock cycles.

For bit 11:  
The infeed is faulted or has failed. Check the infeed and the surroundings (line supply, filter, reactors, fuses, ...). Check the closed-loop infeed control.

For bit 15:  
Group fault. Determine the precise cause of the fault using the commissioning tool.

**p3117**

**Change safety message type / Ch. SI mess type**

<b>Access level:</b> 3	<b>Calculated:</b> -	<b>Data type:</b> Unsigned32
<b>Can be changed:</b> -	<b>Scaling:</b> -	<b>Dynamic index:</b> -
<b>Unit group:</b> -	<b>Unit selection:</b> -	<b>Function diagram:</b> -
<b>Min:</b> 0	<b>Max:</b> 1	<b>Factory setting:</b> 0

**Description:**

Sets the re-parameterization of all safety messages for faults and alarms.  
The relevant message type during changeover is selected by the firmware.  
0: Safety messages are not re-parameterized  
1: Safety messages are re-parameterized

**Note**

A change only becomes effective after a POWER ON.



---

<b>r3120[0...63]</b>	<b>Component fault / Comp fault</b>		
	<b>Access level:</b> 3	<b>Calculated:</b> -	<b>Data type:</b> Integer16
	<b>Can be changed:</b> -	<b>Scaling:</b> -	<b>Dynamic index:</b> -
	<b>Unit group:</b> -	<b>Unit selection:</b> -	<b>Function diagram:</b> 8060
	<b>Min:</b> 0	<b>Max:</b> 3	<b>Factory setting:</b> -
<b>Description:</b>	Displays the component of the fault which has occurred.		
<b>Value:</b>	0: No assignment 1: Control Unit 2: Power Module 3: Motor		
<b>Dependency:</b>	See also: r0945, r0947, r0948, r0949, r2109, r2130, r2133, r2136, r3122		

**Note**

The buffer parameters are cyclically updated in the background (refer to status signal in r2139).  
The structure of the fault buffer and the assignment of the indices is shown in r0945.

---



---

<b>r3121[0...63]</b>	<b>Component alarm / Comp alarm</b>		
	<b>Access level:</b> 3	<b>Calculated:</b> -	<b>Data type:</b> Integer16
	<b>Can be changed:</b> -	<b>Scaling:</b> -	<b>Dynamic index:</b> -
	<b>Unit group:</b> -	<b>Unit selection:</b> -	<b>Function diagram:</b> 8065
	<b>Min:</b> 0	<b>Max:</b> 3	<b>Factory setting:</b> -
<b>Description:</b>	Displays the component of the alarm which has occurred.		
<b>Value:</b>	0: No assignment 1: Control Unit 2: Power Module 3: Motor		
<b>Dependency:</b>	See also: r2110, r2122, r2123, r2124, r2125, r2134, r2145, r2146, r3123		

**Note**

The buffer parameters are cyclically updated in the background (refer to status signal in r2139).  
The structure of the alarm buffer and the assignment of the indices is shown in r2122.

---



---

<b>r3122[0...63]</b>	<b>Diagnostic attribute fault / Diag_attr fault</b>				
	<b>Access level:</b> 3	<b>Calculated:</b> -	<b>Data type:</b> Unsigned32		
	<b>Can be changed:</b> -	<b>Scaling:</b> -	<b>Dynamic index:</b> -		
	<b>Unit group:</b> -	<b>Unit selection:</b> -	<b>Function diagram:</b> 8060		
	<b>Min:</b> -	<b>Max:</b> -	<b>Factory setting:</b> -		
<b>Description:</b>	Displays the diagnostic attribute of the fault which has occurred.				
<b>Bit field:</b>	<b>Bit</b>	<b>Signal name</b>	<b>1 signal</b>	<b>0 signal</b>	<b>FP</b>
	00	Hardware replacement recommended	Yes	No	-
	15	Message has gone	Yes	No	-
	16	PROFIdrive fault class bit 0	High	Low	-
	17	PROFIdrive fault class bit 1	High	Low	-
	18	PROFIdrive fault class bit 2	High	Low	-
	19	PROFIdrive fault class bit 3	High	Low	-
	20	PROFIdrive fault class bit 4	High	Low	-
<b>Dependency:</b>	See also: r0945, r0947, r0948, r0949, r2109, r2130, r2133, r2136, r3120				

7.3 Parameter list

**Note**

The buffer parameters are cyclically updated in the background (refer to status signal in r2139).

The structure of the fault buffer and the assignment of the indices is shown in r0945.

For bits 20 ... 16:

Bits 20, 19, 18, 17, 16 = 0, 0, 0, 0, 0 --> PROFIdrive message class 0: not assigned

Bits 20, 19, 18, 17, 16 = 0, 0, 0, 0, 1 --> PROFIdrive message class 1: hardware fault/software error

Bits 20, 19, 18, 17, 16 = 0, 0, 0, 1, 0 --> PROFIdrive message class 2: line fault

Bits 20, 19, 18, 17, 16 = 0, 0, 0, 1, 1 --> PROFIdrive message class 3: supply voltage fault

Bits 20, 19, 18, 17, 16 = 0, 0, 1, 0, 0 --> PROFIdrive message class 4: DC link fault

Bits 20, 19, 18, 17, 16 = 0, 0, 1, 0, 1 --> PROFIdrive message class 5: power electronics faulted

Bits 20, 19, 18, 17, 16 = 0, 0, 1, 1, 0 --> PROFIdrive message class 6: overtemperature electronic components

Bits 20, 19, 18, 17, 16 = 0, 0, 1, 1, 1 --> PROFIdrive message class 7: ground fault/phase fault detected

Bits 20, 19, 18, 17, 16 = 0, 1, 0, 0, 0 --> PROFIdrive message class 8: motor overload

Bits 20, 19, 18, 17, 16 = 0, 1, 0, 0, 1 --> PROFIdrive message class 9: communication error to the higher-level control

Bits 20, 19, 18, 17, 16 = 0, 1, 0, 1, 0 --> PROFIdrive message class 10: safe monitoring channel has identified an error

Bits 20, 19, 18, 17, 16 = 0, 1, 0, 1, 1 --> PROFIdrive message class 11: incorrect position actual value/speed actual value or not available

Bits 20, 19, 18, 17, 16 = 0, 1, 1, 0, 0 --> PROFIdrive message class 12: internal (DRIVE-CLiQ) communication error

Bits 20, 19, 18, 17, 16 = 0, 1, 1, 0, 1 --> PROFIdrive message class 13: infeed unit faulted

Bits 20, 19, 18, 17, 16 = 0, 1, 1, 1, 0 --> PROFIdrive message class 14: braking controller/Braking Module faulted

Bits 20, 19, 18, 17, 16 = 0, 1, 1, 1, 1 --> PROFIdrive message class 15: line filter faulted

Bits 20, 19, 18, 17, 16 = 1, 0, 0, 0, 0 --> PROFIdrive message class 16: external measured value/signal state outside the permissible range

Bits 20, 19, 18, 17, 16 = 1, 0, 0, 0, 1 --> PROFIdrive message class 17: application/technology function faulted

Bits 20, 19, 18, 17, 16 = 1, 0, 0, 1, 0 --> PROFIdrive message class 18: error in the parameterization/configuration/commissioning sequence

Bits 20, 19, 18, 17, 16 = 1, 0, 0, 1, 1 --> PROFIdrive message class 19: general drive fault

Bits 20, 19, 18, 17, 16 = 0, 1, 1, 0, 0 --> PROFIdrive message class 20: auxiliary unit faulted

**r3123[0...63]**

**Diagnostic attribute alarm / Diag\_attr alarm**

**Access level:** 3

**Calculated:** -

**Data type:** Unsigned32

**Can be changed:** -

**Scaling:** -

**Dynamic index:** -

**Unit group:** -

**Unit selection:** -

**Function diagram:** 8065

**Min:**

**Max:**

**Factory setting:**

-

-

-

**Description:**

Displays the diagnostic attribute of the alarm which has occurred.

**Bit field:**

Bit	Signal name	1 signal	0 signal	FP
00	Hardware replacement recommended	Yes	No	-
11	Alarm class bit 0	High	Low	-
12	Alarm class bit 1	High	Low	-
13	Maintenance required	Yes	No	-
14	Maintenance urgently required	Yes	No	-
15	Message has gone	Yes	No	-
16	PROFIdrive fault class bit 0	High	Low	-
17	PROFIdrive fault class bit 1	High	Low	-
18	PROFIdrive fault class bit 2	High	Low	-
19	PROFIdrive fault class bit 3	High	Low	-
20	PROFIdrive fault class bit 4	High	Low	-

**Dependency:**

See also: r2110, r2122, r2123, r2124, r2125, r2134, r2145, r2146, r3121

**Note**

The buffer parameters are cyclically updated in the background (refer to status signal in r2139).

The structure of the alarm buffer and the assignment of the indices is shown in r2122.

For bit 12, 11:

These status bits are used for the classification of internal alarm classes and are intended for diagnostic purposes only on certain automation systems with integrated SINAMICS functionality.

For bits 20 ... 16:

Bits 20, 19, 18, 17, 16 = 0, 0, 0, 0, 0 --> PROFIdrive message class 0: not assigned

Bits 20, 19, 18, 17, 16 = 0, 0, 0, 0, 1 --> PROFIdrive message class 1: hardware fault/software error

Bits 20, 19, 18, 17, 16 = 0, 0, 0, 1, 0 --> PROFIdrive message class 2: line fault

Bits 20, 19, 18, 17, 16 = 0, 0, 0, 1, 1 --> PROFIdrive message class 3: supply voltage fault

Bits 20, 19, 18, 17, 16 = 0, 0, 1, 0, 0 --> PROFIdrive message class 4: DC link fault

Bits 20, 19, 18, 17, 16 = 0, 0, 1, 0, 1 --> PROFIdrive message class 5: power electronics faulted

Bits 20, 19, 18, 17, 16 = 0, 0, 1, 1, 0 --> PROFIdrive message class 6: overtemperature electronic components

Bits 20, 19, 18, 17, 16 = 0, 0, 1, 1, 1 --> PROFIdrive message class 7: ground fault/phase fault detected

Bits 20, 19, 18, 17, 16 = 0, 1, 0, 0, 0 --> PROFIdrive message class 8: motor overload

Bits 20, 19, 18, 17, 16 = 0, 1, 0, 0, 1 --> PROFIdrive message class 9: communication error to the higher-level control

Bits 20, 19, 18, 17, 16 = 0, 1, 0, 1, 0 --> PROFIdrive message class 10: safe monitoring channel has identified an error

Bits 20, 19, 18, 17, 16 = 0, 1, 0, 1, 1 --> PROFIdrive message class 11: incorrect position actual value/speed actual value or not available

Bits 20, 19, 18, 17, 16 = 0, 1, 1, 0, 0 --> PROFIdrive message class 12: internal (DRIVE-CLiQ) communication error

Bits 20, 19, 18, 17, 16 = 0, 1, 1, 0, 1 --> PROFIdrive message class 13: infeed unit faulted

Bits 20, 19, 18, 17, 16 = 0, 1, 1, 1, 0 --> PROFIdrive message class 14: braking controller/Braking Module faulted

Bits 20, 19, 18, 17, 16 = 0, 1, 1, 1, 1 --> PROFIdrive message class 15: line filter faulted

Bits 20, 19, 18, 17, 16 = 1, 0, 0, 0, 0 --> PROFIdrive message class 16: external measured value/signal state outside the permissible range

Bits 20, 19, 18, 17, 16 = 1, 0, 0, 0, 1 --> PROFIdrive message class 17: application/technology function faulted

Bits 20, 19, 18, 17, 16 = 1, 0, 0, 1, 0 --> PROFIdrive message class 18: error in the parameterization/configuration/commissioning sequence

Bits 20, 19, 18, 17, 16 = 1, 0, 0, 1, 1 --> PROFIdrive message class 19: general drive fault

Bits 20, 19, 18, 17, 16 = 0, 1, 1, 0, 0 --> PROFIdrive message class 20: auxiliary unit faulted

**r3131****CO: Actual fault value / Act fault val**

**Access level:** 3

**Can be changed:** -

**Unit group:** -

**Min:**

-

**Calculated:** -

**Scaling:** -

**Unit selection:** -

**Max:**

-

**Data type:** Integer32

**Dynamic index:** -

**Function diagram:** 8060

**Factory setting:**

-

**Description:**

Displays the fault value of the oldest active fault.

**Dependency:**

See also: r2131, r3132

**r3132****CO: Actual component number / Comp\_no act**

**Access level:** 3

**Can be changed:** -

**Unit group:** -

**Min:**

-

**Calculated:** -

**Scaling:** -

**Unit selection:** -

**Max:**

-

**Data type:** Integer32

**Dynamic index:** -

**Function diagram:** 8060

**Factory setting:**

-

**Description:**

Displays the component number of the oldest fault that is still active.

**Dependency:**

See also: r2131, r3131

<b>p3230[0...n]</b>	<b>CI: Load monitoring speed actual value / Load monit n_act</b>		
	<b>Access level:</b> 3	<b>Calculated:</b> -	<b>Data type:</b> Unsigned32 / FloatingPoint32
	<b>Can be changed:</b> T	<b>Scaling:</b> p2000	<b>Dynamic index:</b> CDS, p0170
	<b>Unit group:</b> -	<b>Unit selection:</b> -	<b>Function diagram:</b> 8012, 8013
	<b>Min:</b> -	<b>Max:</b> -	<b>Factory setting:</b> 0
<b>Description:</b>	Sets the signal source for the speed actual value of the load monitoring.		
<b>Dependency:</b>	See also: r2169, p2181, p2192, p2193, p3231 See also: A07920, A07921, A07922, F07923, F07924, F07925		
	<b>Note</b> The parameter is only effective for p2193 = 2.		
<b>p3231[0...n]</b>	<b>Load monitoring speed deviation / Load monit n_dev</b>		
	<b>Access level:</b> 3	<b>Calculated:</b> -	<b>Data type:</b> FloatingPoint32
	<b>Can be changed:</b> T, U	<b>Scaling:</b> -	<b>Dynamic index:</b> DDS, p0180
	<b>Unit group:</b> 3_1	<b>Unit selection:</b> p0505	<b>Function diagram:</b> 8013
	<b>Min:</b> 0.00 [rpm]	<b>Max:</b> 210000.00 [rpm]	<b>Factory setting:</b> 150.00 [rpm]
<b>Description:</b>	Sets the permissible speed deviation during load monitoring (for p2193 = 2).		
<b>Dependency:</b>	See also: r2169, p2181, p2193, p3230 See also: A07920, A07921, A07922, F07923, F07924, F07925		
<b>p3232[0...n]</b>	<b>BI: Load monitoring failure detection / Load_moni fail_det</b>		
	<b>Access level:</b> 3	<b>Calculated:</b> -	<b>Data type:</b> Unsigned32 / Binary
	<b>Can be changed:</b> T, U	<b>Scaling:</b> -	<b>Dynamic index:</b> CDS, p0170
	<b>Unit group:</b> -	<b>Unit selection:</b> -	<b>Function diagram:</b> 8013
	<b>Min:</b> -	<b>Max:</b> -	<b>Factory setting:</b> 1
<b>Description:</b>	Sets the signal source for detecting a failure.		
<b>Dependency:</b>	See also: p2192, p2193 See also: F07936		
	<b>Note</b> Monitoring is triggered with a 0 signal, as soon as the time in p2192 has expired.		
<b>p3233[0...n]</b>	<b>Torque actual value filter time constant / M_act_filt T</b>		
	<b>Access level:</b> 3	<b>Calculated:</b> -	<b>Data type:</b> FloatingPoint32
	<b>Can be changed:</b> T, U	<b>Scaling:</b> -	<b>Dynamic index:</b> DDS, p0180
	<b>Unit group:</b> -	<b>Unit selection:</b> -	<b>Function diagram:</b> 8013
	<b>Min:</b> 0 [ms]	<b>Max:</b> 1000000 [ms]	<b>Factory setting:</b> 100 [ms]
<b>Description:</b>	Sets the time constant for the PT1 element to smooth the torque actual value. The smoothed torque actual value is compared with the threshold values and is only used for messages and signals.		

<b>r3313</b>	<b>Efficiency optimization 2 optimum flux / Optimum flux</b>		
	<b>Access level:</b> 3	<b>Calculated:</b> -	<b>Data type:</b> FloatingPoint32
<b>Description:</b> <b>Dependency:</b>	<b>Can be changed:</b> -	<b>Scaling:</b> r2004	<b>Dynamic index:</b> -
	<b>Unit group:</b> -	<b>Unit selection:</b> -	<b>Function diagram:</b> 6722, 6837
	<b>Min:</b> - [%]	<b>Max:</b> - [%]	<b>Factory setting:</b> - [%]
	Displays the calculated, optimum flux.		
	See also: p1401, p3315, p3316		
<b>Note</b>			
The function is activated via p1401.14 = 1.			

<b>p3315[0...n]</b>	<b>Efficiency optimization 2 minimum flux limit value / Min flux lim val</b>		
	<b>Access level:</b> 3	<b>Calculated:</b> -	<b>Data type:</b> FloatingPoint32
<b>Description:</b> <b>Dependency:</b>	<b>Can be changed:</b> T, U	<b>Scaling:</b> -	<b>Dynamic index:</b> DDS, p0180
	<b>Unit group:</b> -	<b>Unit selection:</b> -	<b>Function diagram:</b> 6722, 6837
	<b>Min:</b> 10.0 [%]	<b>Max:</b> 200.0 [%]	<b>Factory setting:</b> 50.0 [%]
	Sets the minimal limit value for the calculated optimum flux.		
	See also: p1401, r3313, p3316		
<b>Note</b>			
The function is activated via p1401.14 = 1.			

<b>p3316[0...n]</b>	<b>Efficiency optimization 2 maximum flux limit value / Max flux lim val</b>		
	<b>Access level:</b> 3	<b>Calculated:</b> -	<b>Data type:</b> FloatingPoint32
<b>Description:</b> <b>Dependency:</b>	<b>Can be changed:</b> T, U	<b>Scaling:</b> -	<b>Dynamic index:</b> DDS, p0180
	<b>Unit group:</b> -	<b>Unit selection:</b> -	<b>Function diagram:</b> 6722, 6837
	<b>Min:</b> 10.0 [%]	<b>Max:</b> 200.0 [%]	<b>Factory setting:</b> 110.0 [%]
	Sets the maximum limit value for the calculated optimum flux.		
	See also: p1401, r3313, p3315		
<b>Note</b>			
The function is activated via p1401.14 = 1.			

<b>p3320[0...n]</b>	<b>Fluid flow machine power point 1 / Fluid_mach P1</b>		
	<b>Access level:</b> 2	<b>Calculated:</b> -	<b>Data type:</b> FloatingPoint32
<b>Description:</b>	<b>Can be changed:</b> T, U	<b>Scaling:</b> -	<b>Dynamic index:</b> DDS, p0180
	<b>Unit group:</b> -	<b>Unit selection:</b> -	<b>Function diagram:</b> -
	<b>Min:</b> 0.00	<b>Max:</b> 100.00	<b>Factory setting:</b> 25.00
	For the energy-saving display of a fluid-flow machine, a typical flow characteristic $P = f(n)$ with 5 points along the characteristic is required.		
	This parameter specifies the power (P) of point 1 as a [%]. The characteristic comprises the following value pairs: Power (P) / speed (n) p3320 / p3321 --> point 1 (P1 / n1) p3322 / p3323 --> point 2 (P2 / n2) p3324 / p3325 --> point 3 (P3 / n3) p3326 / p3327 --> point 4 (P4 / n4) p3328 / p3329 --> point 5 (P5 / n5)		

## 7.3 Parameter list

**Dependency:** See also: r0041, p3321, p3322, p3323, p3324, p3325, p3326, p3327, p3328, p3329

**Note**

The reference value for power and speed is the rated power/rated speed.  
The energy saved is displayed in r0041.

**p3321[0...n] Fluid flow machine speed point 1 / Fluid\_mach n1**

<b>Access level:</b> 2	<b>Calculated:</b> -	<b>Data type:</b> FloatingPoint32
<b>Can be changed:</b> T, U	<b>Scaling:</b> -	<b>Dynamic index:</b> DDS, p0180
<b>Unit group:</b> -	<b>Unit selection:</b> -	<b>Function diagram:</b> -
<b>Min:</b> 0.00	<b>Max:</b> 100.00	<b>Factory setting:</b> 0.00

**Description:** For the energy-saving display of a fluid-flow machine, a typical flow characteristic  $P = f(n)$  with 5 points along the characteristic is required.

This parameter specifies the speed (n) of point 1 as a [%].

The characteristic comprises the following value pairs:

Power (P) / speed (n)

p3320 / p3321 --> point 1 (P1 / n1)

p3322 / p3323 --> point 2 (P2 / n2)

p3324 / p3325 --> point 3 (P3 / n3)

p3326 / p3327 --> point 4 (P4 / n4)

p3328 / p3329 --> point 5 (P5 / n5)

**Dependency:** See also: r0041, p3320, p3322, p3323, p3324, p3325, p3326, p3327, p3328, p3329

**Note**

The reference value for power and speed is the rated power/rated speed.  
The energy saved is displayed in r0041.

**p3322[0...n] Fluid flow machine power point 2 / Fluid\_mach P2**

<b>Access level:</b> 2	<b>Calculated:</b> -	<b>Data type:</b> FloatingPoint32
<b>Can be changed:</b> T, U	<b>Scaling:</b> -	<b>Dynamic index:</b> DDS, p0180
<b>Unit group:</b> -	<b>Unit selection:</b> -	<b>Function diagram:</b> -
<b>Min:</b> 0.00	<b>Max:</b> 100.00	<b>Factory setting:</b> 50.00

**Description:** For the energy-saving display of a fluid-flow machine, a typical flow characteristic  $P = f(n)$  with 5 points along the characteristic is required.

This parameter specifies the power (P) of point 2 as a [%].

**Dependency:** See also: r0041, p3320, p3321, p3323, p3324, p3325, p3326, p3327, p3328, p3329

**Note**

The reference value for power and speed is the rated power/rated speed.  
The energy saved is displayed in r0041.

**p3323[0...n] Fluid flow machine speed point 2 / Fluid\_mach n2**

<b>Access level:</b> 2	<b>Calculated:</b> -	<b>Data type:</b> FloatingPoint32
<b>Can be changed:</b> T, U	<b>Scaling:</b> -	<b>Dynamic index:</b> DDS, p0180
<b>Unit group:</b> -	<b>Unit selection:</b> -	<b>Function diagram:</b> -
<b>Min:</b> 0.00	<b>Max:</b> 100.00	<b>Factory setting:</b> 25.00

**Description:** For the energy-saving display of a fluid-flow machine, a typical flow characteristic  $P = f(n)$  with 5 points along the characteristic is required.

This parameter specifies the speed (n) of point 2 as a [%].

**Dependency:** See also: r0041, p3320, p3321, p3322, p3324, p3325, p3326, p3327, p3328, p3329

**Note**

The reference value for power and speed is the rated power/rated speed.  
The energy saved is displayed in r0041.

**p3324[0...n]****Fluid flow machine power point 3 / Fluid\_mach P3****Access level:** 2**Calculated:** -**Data type:** FloatingPoint32**Can be changed:** T, U**Scaling:** -**Dynamic index:** DDS, p0180**Unit group:** -**Unit selection:** -**Function diagram:** -**Min:****Max:****Factory setting:**

0.00

100.00

77.00

**Description:**

For the energy-saving display of a fluid-flow machine, a typical flow characteristic  $P = f(n)$  with 5 points along the characteristic is required.

This parameter specifies the power (P) of point 3 as a [%].

**Dependency:**

See also: r0041, p3320, p3321, p3322, p3323, p3325, p3326, p3327, p3328, p3329

**Note**

The reference value for power and speed is the rated power/rated speed.  
The energy saved is displayed in r0041.

**p3325[0...n]****Fluid flow machine speed point 3 / Fluid\_mach n3****Access level:** 2**Calculated:** -**Data type:** FloatingPoint32**Can be changed:** T, U**Scaling:** -**Dynamic index:** DDS, p0180**Unit group:** -**Unit selection:** -**Function diagram:** -**Min:****Max:****Factory setting:**

0.00

100.00

50.00

**Description:**

For the energy-saving display of a fluid-flow machine, a typical flow characteristic  $P = f(n)$  with 5 points along the characteristic is required.

This parameter specifies the speed (n) of point 3 as a [%].

**Dependency:**

See also: r0041, p3320, p3321, p3322, p3323, p3324, p3326, p3327, p3328, p3329

**Note**

The reference value for power and speed is the rated power/rated speed.  
The energy saved is displayed in r0041.

**p3326[0...n]****Fluid flow machine power point 4 / Fluid\_mach P4****Access level:** 2**Calculated:** -**Data type:** FloatingPoint32**Can be changed:** T, U**Scaling:** -**Dynamic index:** DDS, p0180**Unit group:** -**Unit selection:** -**Function diagram:** -**Min:****Max:****Factory setting:**

0.00

100.00

92.00

**Description:**

For the energy-saving display of a fluid-flow machine, a typical flow characteristic  $P = f(n)$  with 5 points along the characteristic is required.

This parameter specifies the power (P) of point 4 as a [%].

**Dependency:**

See also: r0041, p3320, p3321, p3322, p3323, p3324, p3325, p3327, p3328, p3329

**Note**

The reference value for power and speed is the rated power/rated speed.  
The energy saved is displayed in r0041.

## 7.3 Parameter list

<b>p3327[0...n]</b>	<b>Fluid flow machine speed point 4 / Fluid_mach n4</b>		
	<b>Access level:</b> 2	<b>Calculated:</b> -	<b>Data type:</b> FloatingPoint32
	<b>Can be changed:</b> T, U	<b>Scaling:</b> -	<b>Dynamic index:</b> DDS, p0180
	<b>Unit group:</b> -	<b>Unit selection:</b> -	<b>Function diagram:</b> -
	<b>Min:</b> 0.00	<b>Max:</b> 100.00	<b>Factory setting:</b> 75.00
<b>Description:</b>	For the energy-saving display of a fluid-flow machine, a typical flow characteristic $P = f(n)$ with 5 points along the characteristic is required. This parameter specifies the speed (n) of point 4 as a [%].		
<b>Dependency:</b>	See also: r0041, p3320, p3321, p3322, p3323, p3324, p3325, p3326, p3328, p3329		
	<b>Note</b> The reference value for power and speed is the rated power/rated speed. The energy saved is displayed in r0041.		
<b>p3328[0...n]</b>	<b>Fluid flow machine power point 5 / Fluid_mach P5</b>		
	<b>Access level:</b> 2	<b>Calculated:</b> -	<b>Data type:</b> FloatingPoint32
	<b>Can be changed:</b> T, U	<b>Scaling:</b> -	<b>Dynamic index:</b> DDS, p0180
	<b>Unit group:</b> -	<b>Unit selection:</b> -	<b>Function diagram:</b> -
	<b>Min:</b> 0.00	<b>Max:</b> 100.00	<b>Factory setting:</b> 100.00
<b>Description:</b>	For the energy-saving display of a fluid-flow machine, a typical flow characteristic $P = f(n)$ with 5 points along the characteristic is required. This parameter specifies the power (P) of point 5 as a [%].		
<b>Dependency:</b>	See also: r0041, p3320, p3321, p3322, p3323, p3324, p3325, p3326, p3327, p3329		
	<b>Note</b> The reference value for power and speed is the rated power/rated speed. The energy saved is displayed in r0041.		
<b>p3329[0...n]</b>	<b>Fluid flow machine speed point 5 / Fluid_mach n5</b>		
	<b>Access level:</b> 2	<b>Calculated:</b> -	<b>Data type:</b> FloatingPoint32
	<b>Can be changed:</b> T, U	<b>Scaling:</b> -	<b>Dynamic index:</b> DDS, p0180
	<b>Unit group:</b> -	<b>Unit selection:</b> -	<b>Function diagram:</b> -
	<b>Min:</b> 0.00	<b>Max:</b> 100.00	<b>Factory setting:</b> 100.00
<b>Description:</b>	For the energy-saving display of a fluid-flow machine, a typical flow characteristic $P = f(n)$ with 5 points along the characteristic is required. This parameter specifies the speed (n) of point 5 as a [%].		
<b>Dependency:</b>	See also: r0041, p3320, p3321, p3322, p3323, p3324, p3325, p3326, p3327, p3328		
	<b>Note</b> The reference value for power and speed is the rated power/rated speed. The energy saved is displayed in r0041.		
<b>p3330[0...n]</b>	<b>BI: 2/3 wire control command 1 / 2/3 wire cmd 1</b>		
	<b>Access level:</b> 3	<b>Calculated:</b> -	<b>Data type:</b> Unsigned32 / Binary
	<b>Can be changed:</b> T, U	<b>Scaling:</b> -	<b>Dynamic index:</b> CDS, p0170
	<b>Unit group:</b> -	<b>Unit selection:</b> -	<b>Function diagram:</b> 2272, 2273
	<b>Min:</b> -	<b>Max:</b> -	<b>Factory setting:</b> 0
<b>Description:</b>	Sets the signal source for command 1 for the two-wire control/three-wire control.		



**Dependency:** See also: p0015, p3331, p3332, r3333

**Note**

The mode of operation of this binector input is dependent on the wire control set in p0015.

**p3331[0...n]**

**BI: 2/3 wire control command 2 / 2/3 wire cmd 2**

**Access level:** 3

**Calculated:** -

**Data type:** Unsigned32 / Binary

**Can be changed:** T, U

**Scaling:** -

**Dynamic index:** CDS, p0170

**Unit group:** -

**Unit selection:** -

**Function diagram:** 2272, 2273

**Min:**

**Max:**

**Factory setting:**

-

-

0

**Description:**

Sets the signal source for command 2 for the two-wire control/three-wire control.

**Dependency:**

See also: p0015, p3330, p3332, r3333

**Note**

The mode of operation of this binector input is dependent on the wire control set in p0015.

**p3332[0...n]**

**BI: 2/3 wire control command 3 / 2/3 wire cmd 3**

**Access level:** 3

**Calculated:** -

**Data type:** Unsigned32 / Binary

**Can be changed:** T, U

**Scaling:** -

**Dynamic index:** CDS, p0170

**Unit group:** -

**Unit selection:** -

**Function diagram:** 2273

**Min:**

**Max:**

**Factory setting:**

-

-

0

**Description:**

Sets the signal source for command 3 for the two-wire control/three-wire control.

**Dependency:**

See also: p0015, p3330, p3331, r3333

**Note**

The mode of operation of this binector input is dependent on the wire control set in p0015.

**r3333.0...3**

**CO/BO: 2/3 wire control control word / 2/3 wire STW**

**Access level:** 3

**Calculated:** -

**Data type:** Unsigned32

**Can be changed:** -

**Scaling:** -

**Dynamic index:** -

**Unit group:** -

**Unit selection:** -

**Function diagram:** 2272, 2273

**Min:**

**Max:**

**Factory setting:**

-

-

-

**Description:**

Displays the control word for the two wire control/three wire control.

The control signals are dependent on the wire control set in p0015 and the signal states at the digital inputs.

**Bit field:**

Bit	Signal name	1 signal	0 signal	FP
00	ON	Yes	No	-
01	Reversing	Yes	No	-
02	ON inverted	Yes	No	-
03	Reversing inverted	Yes	No	-

**Dependency:**

See also: p0015, p3330, p3331, p3332

**p3340[0...n]**

**BI: Limit switch start / Lim switch start**

**Access level:** 3

**Calculated:** -

**Data type:** Unsigned32 / Binary

**Can be changed:** T

**Scaling:** -

**Dynamic index:** CDS, p0170

**Unit group:** -

**Unit selection:** -

**Function diagram:** -

**Min:**

**Max:**

**Factory setting:**

-

-

0

**Description:**

Sets the signal source for the start of motion dependent on the sign of the setpoint.

7.3 Parameter list

**Dependency:** See also: p3342, p3343, r3344  
See also: A07352

**p3342[0...n]**      **BI: Limit switch plus / Lim switch plus**

<b>Access level:</b> 3	<b>Calculated:</b> -	<b>Data type:</b> Unsigned32 / Binary
<b>Can be changed:</b> T	<b>Scaling:</b> -	<b>Dynamic index:</b> CDS, p0170
<b>Unit group:</b> -	<b>Unit selection:</b> -	<b>Function diagram:</b> -
<b>Min:</b>	<b>Max:</b>	<b>Factory setting:</b>
-	-	1

**Description:** Sets the signal source for the limit switch plus.  
 BI: p3342 = 1-signal:  
 Limit switch is inactive.  
 BI: p3342 = 0 signal:  
 Limit switch is active.

**Dependency:** See also: p3340, p3343, r3344

**Note**

For p1113 = 0, the drive traverses with a positive speed setpoint towards the positive limit switch – or for p1113 = 1 with a negative speed setpoint.

**p3343[0...n]**      **BI: Limit switch minus / Lim switch minus**

<b>Access level:</b> 3	<b>Calculated:</b> -	<b>Data type:</b> Unsigned32 / Binary
<b>Can be changed:</b> T	<b>Scaling:</b> -	<b>Dynamic index:</b> CDS, p0170
<b>Unit group:</b> -	<b>Unit selection:</b> -	<b>Function diagram:</b> -
<b>Min:</b>	<b>Max:</b>	<b>Factory setting:</b>
-	-	1

**Description:** Sets the signal source for the limit switch minus.  
 BI: p3343 = 1-signal:  
 Limit switch is inactive.  
 BI: p3343 = 0 signal:  
 Limit switch is active.

**Dependency:** See also: p3340, p3342, r3344

**Note**

For p1113 = 0, the drive traverses with a negative speed setpoint towards the minus limit switch – or for p1113 = 1 with a positive speed setpoint.

**r3344.0...5**      **CO/BO: Limit switch status word / Lim sw ZSW**

<b>Access level:</b> 3	<b>Calculated:</b> -	<b>Data type:</b> Unsigned16
<b>Can be changed:</b> -	<b>Scaling:</b> -	<b>Dynamic index:</b> -
<b>Unit group:</b> -	<b>Unit selection:</b> -	<b>Function diagram:</b> -
<b>Min:</b>	<b>Max:</b>	<b>Factory setting:</b>
-	-	-

**Description:** Display and BICO output for the status word of the limit switch.

<b>Bit field:</b>	<b>Bit</b>	<b>Signal name</b>	<b>1 signal</b>	<b>0 signal</b>	<b>FP</b>
	00	Limit switch ON/OFF1	Yes	No	-
	01	Limit switch OFF3	No	Yes	-
	02	Limit switch axis stationary (standstill)	Yes	No	-
	04	Plus limit switch reached	Yes	No	-
	05	Minus limit switch reached	Yes	No	-

**Dependency:** See also: p3340, p3342, p3343

**Note**

For bit 00 = 1:

The limit switch enables motion.

For example, this bit can be used for interconnection with binector input p0840 (ON/OFF1).

For bit 01 = 0:

The drive cannot be moved as a result of the limit switch function (e.g. as a result of the switching on inhibited).

For example, this bit can be used for interconnection with binector input p0848 (OFF3).

For bit 02 = 1:

The axis is at zero speed.

For bit 04 = 1:

The plus limit switch reached.

For bit 05 = 1:

The minus limit switch reached.

**p3380****Forming activation/duration / Form act/duration**

**Access level:** 3

**Calculated:** -

**Data type:** FloatingPoint32

**Can be changed:** T

**Scaling:** -

**Dynamic index:** -

**Unit group:** -

**Unit selection:** -

**Function diagram:** -

**Min:**

**Max:**

**Factory setting:**

0.0 [h]

10.0 [h]

0.0 [h]

**Description:**

Setting to activate the "DC link capacitor forming" function.

This value also defines the forming duration.

The function is deactivated with p3380 = 0.

**Recommendation:**

Recommended forming duration depending on the storage time:

1 - 2 years: p3380 = 1 hour

2 - 3 years: p3380 = 2 hours

>3 years: p3380 = 8 hours

**Dependency:**

The "DC link capacitor forming" function can only be executed when commissioning the power unit (p0010 = 2). The function is automatically deactivated (p3380 = 0) once commissioning has been exited (p0010 = 0).

Procedure when forming:

1. Activate power unit commissioning (p0010 = 2).
2. Activate forming (p3380 > 0, value, see recommendation).
3. Switch on the drive unit (p0840 = 0/1 signal).
4. Wait for forming to be completed (r3381 = 0).
5. Exit power unit commissioning (p0010 = 0).

See also: r3381, r3382

See also: F07390, A07391

**NOTICE**

If drive units are not commissioned within 2 years after their original manufacture, then the DC link capacitors must be reformed before use. If this is not done, then the units could be damaged in operation.

**Note**

The "DC link capacitor forming" function can only be activated online in the drive unit.

If switched off while forming is active, the remaining time (r3381) is lost, and forming must be repeated for the full forming time. If the forming duration is changed, then forming starts again from the beginning.

**r3381****Forming remaining time / Forming t\_remain**

**Access level:** 3

**Calculated:** -

**Data type:** FloatingPoint32

**Can be changed:** -

**Scaling:** -

**Dynamic index:** -

**Unit group:** -

**Unit selection:** -

**Function diagram:** -

**Min:**

**Max:**

**Factory setting:**

- [h]

- [h]

- [h]

7.3 Parameter list

**Description:** Displays the remaining time after activating the "DC link capacitor forming" function.  
**Dependency:** See also: p3380, r3382

**r3382**      **Forming status word / Forming ZSW**

<b>Access level:</b> 3	<b>Calculated:</b> -	<b>Data type:</b> Unsigned16
<b>Can be changed:</b> -	<b>Scaling:</b> -	<b>Dynamic index:</b> -
<b>Unit group:</b> -	<b>Unit selection:</b> -	<b>Function diagram:</b> -
<b>Min:</b>	<b>Max:</b>	<b>Factory setting:</b>
-	-	-

**Description:** Displays the status word of the "DC link capacitor forming" function.

<b>Bit field:</b>	<b>Bit</b>	<b>Signal name</b>	<b>1 signal</b>	<b>0 signal</b>	<b>FP</b>
	00	Forming activated	Yes	No	-
	01	Forming active	Yes	No	-
	02	Forming completed	Yes	No	-
	03	Forming fault	Yes	No	-

**Dependency:** See also: p3380, r3381  
See also: F07390, A07391

**Note**

For bit 00 = 1:  
The parameter for activation/duration has been set (p3380 > 0) - however, forming has still not been started (p0840 = 0 signal).

For bit 01 = 1:  
The parameter for activation/duration has been set (p3380 > 0) - however, forming has still not been started (p0840 = 0/1 signal).  
This status is displayed through alarm A07391.

The procedure can be interrupted via binector input p0840, p0844, p0848 (r3382.1 = 0) - and reactivated again using p0840.

For bit 03 = 1:  
Forming was not able to be successfully performed within the set duration.  
This status is displayed using fault F07390.

**p3855[0...n]**      **DC quantity controller configuration / Rect\_ctrl config**

<b>Access level:</b> 3	<b>Calculated:</b> CALC_MOD_LIM_REF	<b>Data type:</b> Unsigned32
<b>Can be changed:</b> T, U	<b>Scaling:</b> -	<b>Dynamic index:</b> DDS, p0180
<b>Unit group:</b> -	<b>Unit selection:</b> -	<b>Function diagram:</b> 6797, 6844, 6855
<b>Min:</b>	<b>Max:</b>	<b>Factory setting:</b>
-	-	0111 bin

**Description:** Sets the configuration for the DC quantity controller in the overmodulation range.  
There is no DC quantity control for power units that can also be connected through 1 phase to the line supply (r0204.15 = 1).

<b>Bit field:</b>	<b>Bit</b>	<b>Signal name</b>	<b>1 signal</b>	<b>0 signal</b>	<b>FP</b>
	00	DC quantity controller on	Yes	No	-
	01	Bandwidth increased	Yes	No	-
	02	7th harmonic reduced	Yes	No	-
	03	Filter active	Yes	No	-

**Dependency:** The modulator mode p1802 must enable operation in the overmodulation range. In addition, the overmodulation limit p1803 must be greater than 103 %.  
Set the modulator mode p1802 = 10, if the DC quantity control is deactivated and overmodulation is to be prevented.

<b>NOTICE</b>
Motor identification must be carried out before activating the DC quantity control in the overmodulation range.

<b>p3856[0...n]</b>	<b>Compound braking current / Compound I_brake</b>		
CUG120X_PN (Compound brake)	<b>Access level:</b> 3	<b>Calculated:</b> -	<b>Data type:</b> FloatingPoint32
	<b>Can be changed:</b> T, U	<b>Scaling:</b> PERCENT	<b>Dynamic index:</b> DDS, p0180
	<b>Unit group:</b> -	<b>Unit selection:</b> -	<b>Function diagram:</b> -
	<b>Min:</b> 0.00 [%]	<b>Max:</b> 250.00 [%]	<b>Factory setting:</b> 0.00 [%]
<b>Description:</b>	Compound braking current is used to define the amount of DC current that is produced on stopping the motor during U/f operation to further increase the DC braking function. Compound braking is a superimposition of the DC braking function with regenerative braking (net braking along the ramp) after OFF1 or OFF3. This permits braking with controlled motor frequency and minimum power input into the motor. Effective braking without using additional hardware components is obtained by optimizing the ramp down time and compound braking.		
<b>Dependency:</b>	The compound braking current is only activated if the DC link voltage exceeds the threshold value in r1282. Compound braking does not operate in the following cases: - DC braking activated (p1230, r1239). - motor is still not magnetized (e.g. for flying restart). - vector control parameterized (p1300 >= 20). - synchronous motor used (p0300 = 2xx).		

<b>NOTICE</b>
Generally, increasing the braking current improves the braking effect when stopping the motor. However, if the value is set too high, then the drive can be tripped (shut down) as a result of overcurrent or ground fault. Recommendation: $p3856 < 100 \% \times (r0209 - r0331) / p0305 / 2$ Compound braking generates a current in the motor with a ripple manifesting the rotational frequency. The higher the braking current is set, the higher the resulting ripple, especially when the Vdc_max control is simultaneously active (refer to p1280).

**Note**

The parameter value is entered relative to the rated motor current (p0305).  
Compound braking is deactivated with p3856 = 0%.

<b>p3857[0...n]</b>	<b>DC quantity controller P gain / DC_ctrl Kp</b>		
	<b>Access level:</b> 3	<b>Calculated:</b> CALC_MOD_CON	<b>Data type:</b> FloatingPoint32
	<b>Can be changed:</b> T, U	<b>Scaling:</b> -	<b>Dynamic index:</b> DDS, p0180
	<b>Unit group:</b> -	<b>Unit selection:</b> -	<b>Function diagram:</b> 6797
	<b>Min:</b> 0.000	<b>Max:</b> 100000.000	<b>Factory setting:</b> 0.000
<b>Description:</b>	Sets the proportional gain of the DC quantity controller for the overmodulation range.		
<b>p3858[0...n]</b>	<b>DC quantity controller integral time / DC_ctrl Tn</b>		
	<b>Access level:</b> 3	<b>Calculated:</b> CALC_MOD_CON	<b>Data type:</b> FloatingPoint32
	<b>Can be changed:</b> T, U	<b>Scaling:</b> -	<b>Dynamic index:</b> DDS, p0180
	<b>Unit group:</b> -	<b>Unit selection:</b> -	<b>Function diagram:</b> 6797
	<b>Min:</b> 0.00 [ms]	<b>Max:</b> 1000.00 [ms]	<b>Factory setting:</b> 2.00 [ms]
<b>Description:</b>	Sets the integral time for the DC quantity controller.		



<b>▲ WARNING</b>
For p3881 = 4: If the technology controller is used as setpoint source, then this must first be configured. p2251 must be set to 0.

**Note**

ESM: Essential Service Mode

When the essential service mode is activated, the effective speed setpoint is displayed in r1114.

For p3881 = 0:

The last known setpoint value is only transmitted safely if it was present consistently for at least 30 s prior to activating the essential service mode. If this condition is not met, fixed speed setpoint 15 (p1015) is used.

For p3881 = 6:

n\_act = 0: pulse suppression and switching on inhibited.

n\_active &gt; 0: braking along the ramp-function generator down ramp (p1121), pulse cancellation and switching on inhibited.

For p3881 = 7:

n\_act = 0: pulse suppression and switching on inhibited.

n\_act &gt; 0: immediate pulse cancellation and switching on inhibited.

<b>p3882</b>	<b>ESM setpoint source alternative / ESM setp_src alt</b>		
	<b>Access level:</b> 3	<b>Calculated:</b> -	<b>Data type:</b> Integer16
	<b>Can be changed:</b> T	<b>Scaling:</b> -	<b>Dynamic index:</b> -
	<b>Unit group:</b> -	<b>Unit selection:</b> -	<b>Function diagram:</b> 7033
	<b>Min:</b> 0	<b>Max:</b> 2	<b>Factory setting:</b> 0
<b>Description:</b>	Sets the alternative setpoint source for essential service mode (ESM). This setpoint is used when the setpoint source set in p3881 is lost.		
<b>Value:</b>	0: Last known setpoint (r1078 smoothed) 1: Fixed speed setpoint 15 (p1015) 2: Maximum speed (p1082)		
<b>Dependency:</b>	See also: p3881		

**Note**

ESM: Essential Service Mode

The alternative setpoint source is only active for p3881 = 2, 3, 4.

<b>p3883</b>	<b>BI: ESM direction of rotation signal source / ESM rot dir s s</b>		
	<b>Access level:</b> 3	<b>Calculated:</b> -	<b>Data type:</b> Unsigned32 / Binary
	<b>Can be changed:</b> T	<b>Scaling:</b> -	<b>Dynamic index:</b> -
	<b>Unit group:</b> -	<b>Unit selection:</b> -	<b>Function diagram:</b> 7033
	<b>Min:</b> -	<b>Max:</b> -	<b>Factory setting:</b> 0
<b>Description:</b>	Sets the signal source for the direction of rotation during essential service mode (ESM). p3883 = 1 signal: Direction of rotation of the setpoint, parameterized for essential service mode, is reversed. p3883 = 0 signal: Direction of rotation of the setpoint parameterized for essential service mode is kept.		

**▲ WARNING**

The direction reversal is not taken into account if p3881 = 4 is set (technology controller) and the technology controller is also active as the setpoint source.

**Note**

ESM: Essential Service Mode

7.3 Parameter list

**p3884**      **CI: ESM setpoint technology controller / ESM setp tech\_ctrl**  
**Access level:** 3      **Calculated:** -      **Data type:** Unsigned32 / FloatingPoint32  
**Can be changed:** T, U      **Scaling:** PERCENT      **Dynamic index:** -  
**Unit group:** -      **Unit selection:** -      **Function diagram:** 7033  
**Min:** -      **Max:** -      **Factory setting:** 0  
**Description:** Sets the signal source for the setpoint for p3881 = 4 (technology controller) in the essential service mode (ESM).  
**Dependency:** See also: p3881

**Note**  
 ESM: Essential Service Mode  
 For p3884 = 0:  
 The technology controller uses the setpoint from p2253.

**r3889.0...10**      **CO/BO: ESM status word / ESM ZSW**  
**Access level:** 3      **Calculated:** -      **Data type:** Unsigned32  
**Can be changed:** -      **Scaling:** -      **Dynamic index:** -  
**Unit group:** -      **Unit selection:** -      **Function diagram:** 7033  
**Min:** -      **Max:** -      **Factory setting:** -

**Description:** Display and BICO output for the status word of the essential service mode (ESM).

Bit field:	Bit	Signal name	1 signal	0 signal	FP
	00	Essential service mode (ESM) activated	Yes	No	-
	01	Direction of rotation inverted	Yes	No	-
	02	Setpoint signal lost	Yes	No	-
	03	Technology controller actual value (p2264) lost	Yes	No	-
	04	Bypass active	Yes	No	-
	05	Setpoint technology controller parameterized (p3884)	Yes	No	-
	06	Technology controller during essential service mode active	Yes	No	-
	09	Response OFF1/OFF2 activated	Yes	No	-
	10	Automatic restart interrupted (F07320)	Yes	No	-

**Note**  
 ESM: Essential Service Mode

**p3900**      **Completion of quick commissioning / Compl quick\_comm**  
**Access level:** 1      **Calculated:** -      **Data type:** Integer16  
**Can be changed:** C2(1)      **Scaling:** -      **Dynamic index:** -  
**Unit group:** -      **Unit selection:** -      **Function diagram:** -  
**Min:** 0      **Max:** 3      **Factory setting:** 0



**Description:** Exits quick commissioning (p0010 = 1) with automatic calculation of all parameters of all existing drive data sets that depend on the entries made during quick commissioning.

p3900 = 1 initially includes a parameter reset (factory setting, the same as p0970 = 1) for all parameters of the drive object; however, without overwriting the entries made during the quick commissioning.

The interconnections of PROFIBUS PZD telegram selection (p0922) and the interconnections via p15 and p1500 are re-established and all of the dependent motor, open-loop and control-loop control parameters are calculated (corresponding to p0340 = 1).

p3900 = 2 includes the restoration of the interconnections of PROFIBUS PZD telegram selection (p0922) and the interconnections via p15 and p1500 and the calculations corresponding to p0340 = 1.

p3900 = 3 only includes the calculations associated with the motor, open-loop and closed-loop control parameters corresponding to p0340 = 1.

**Value:**

0: No quick parameterization  
 1: Quick parameterization after parameter reset  
 2: Quick parameterization (only) for BICO and motor parameters  
 3: Quick parameterization for motor parameters (only)

**NOTICE**

After the value has been modified, no further parameter modifications can be made and the status is shown in r3996. Modifications can be made again when r3996 = 0.

**Note**

When the calculations have been completed, p3900 and p0010 are automatically reset to a value of zero.

When calculating motor, open-loop and closed-loop control parameters (such as for p0340 = 1) parameters associated with a selected Siemens catalog motor are not overwritten.

If a catalog motor has not been selected (p0300), then the following parameters are reset with p3900 > 0 in order to restore the situation that applied when commissioning the drive for the first time:

induction motor: p0320, p0352, p0362 ... p0369, p0604, p0605, p0626 ... p0628  
 synchronous motor: p0326, p0327, p0352, p0604, p0605

**r3925[0...n]****Identification final display / Ident final\_disp**

<b>Access level:</b> 3	<b>Calculated:</b> CALC_MOD_ALL	<b>Data type:</b> Unsigned32
<b>Can be changed:</b> -	<b>Scaling:</b> -	<b>Dynamic index:</b> DDS, p0180
<b>Unit group:</b> -	<b>Unit selection:</b> -	<b>Function diagram:</b> -
<b>Min:</b>	<b>Max:</b>	<b>Factory setting:</b>
-	-	-

**Description:** Displays the commissioning steps that have been carried out.

<b>Bit field:</b>	<b>Bit</b>	<b>Signal name</b>	<b>1 signal</b>	<b>0 signal</b>	<b>FP</b>
	00	Motor/control parameters calculated (p0340 = 1, p3900 > 0)	Yes	No	-
	02	Motor data identification carried out at standstill (p1910 = 1)	Yes	No	-
	03	Rotating measurement carried out (p1960 = 1, 2)	Yes	No	-
	08	Identified motor data are automatically backed up	Yes	No	-
	11	Automatic parameterization as Standard Drive Control	Yes	No	-
	12	Automatic parameterization as Dynamic Drive Control	Yes	No	-
	14	First motor commissioning	Yes	No	-
	15	Equivalent circuit diagram parameters changed	Yes	No	-
	18	Circle identification executed	Yes	No	-

**Note**

The individual bits are only set if the appropriate action has been initiated and successfully completed.

The identification final display is reset when changing the type plate parameters.

<b>r3927[0...n] Motor data identification control word / MotID STW</b>					
<b>Access level:</b> 3	<b>Calculated:</b> CALC_MOD_ALL	<b>Data type:</b> Unsigned32			
<b>Can be changed:</b> -	<b>Scaling:</b> -	<b>Dynamic index:</b> DDS, p0180			
<b>Unit group:</b> -	<b>Unit selection:</b> -	<b>Function diagram:</b> -			
<b>Min:</b> -	<b>Max:</b> -	<b>Factory setting:</b> -			
<b>Description:</b>	Successfully completed component of the last motor data identification carried out.				
<b>Bit field:</b>	<b>Bit</b>	<b>Signal name</b>	<b>1 signal</b>	<b>0 signal</b>	<b>FP</b>
	00	Stator inductance estimate no measurement	Yes	No	-
	02	Rotor time constant estimate no measurement	Yes	No	-
	03	Leakage inductance estimate no measurement	Yes	No	-
	05	Determine Tr and Lsig evaluation in the time range	Yes	No	-
	06	Activate vibration damping	Yes	No	-
	07	Deactivate vibration detection	Yes	No	-
	11	Deactivate pulse measurement Lq Ld	Yes	No	-
	12	Deactivate rotor resistance Rr measurement	Yes	No	-
	14	Deactivate valve interlocking time measurement	Yes	No	-
	15	Determine only stator resistance, valve voltage fault, dead time	Yes	No	-
	16	Short motor identification (lower quality)	Yes	No	-
	17	Measurement without control parameter calculation	Yes	No	-
	18	After motID direct transition into operation	Yes	No	-
	19	After MotID automatically save results	Yes	No	-
	20	Estimate cable resistance	Yes	No	-
	21	Calibrating the output voltage measurement	Yes	No	-
	22	Only identify circle	Yes	No	-
	23	Deactivate circle identification	Yes	No	-
	24	Circle identification with 0 and 90 degrees	Yes	No	-
<b>Dependency:</b>	See also: r3925				
<b>Note</b>	The parameter is a copy of p1909.				

<b>r3928[0...n] Rotating measurement configuration / Rot meas config</b>					
<b>Access level:</b> 3	<b>Calculated:</b> CALC_MOD_ALL	<b>Data type:</b> Unsigned16			
<b>Can be changed:</b> -	<b>Scaling:</b> -	<b>Dynamic index:</b> DDS, p0180			
<b>Unit group:</b> -	<b>Unit selection:</b> -	<b>Function diagram:</b> -			
<b>Min:</b> -	<b>Max:</b> -	<b>Factory setting:</b> -			
<b>Description:</b>	Successfully completed component of the last rotating measurement carried out.				
<b>Bit field:</b>	<b>Bit</b>	<b>Signal name</b>	<b>1 signal</b>	<b>0 signal</b>	<b>FP</b>
	01	Saturation characteristic identification	Yes	No	-
	02	Moment of inertia identification	Yes	No	-
	03	Re-calculates the speed controller parameters	Yes	No	-
	04	Speed controller optimization (vibration test)	Yes	No	-
	05	q leakage inductance ident. (for current controller adaptation)	Yes	No	-
	11	Do not change the controller parameters during the measurement	Yes	No	-
	12	Measurement shortened	Yes	No	-
	13	After measurement direct transition into operation	Yes	No	-

<b>Dependency:</b>	14 Calculate speed actual value smoothing time See also: r3925	Yes	No	-	
<b>Note</b> The parameter is a copy of p1959.					
<b>r3930[0...4]</b>	<b>Power unit EEPROM characteristics / PU characteristics</b>				
	<b>Access level:</b> 3	<b>Calculated:</b> -	<b>Data type:</b> Unsigned16		
	<b>Can be changed:</b> -	<b>Scaling:</b> -	<b>Dynamic index:</b> -		
	<b>Unit group:</b> -	<b>Unit selection:</b> -	<b>Function diagram:</b> -		
	<b>Min:</b> -	<b>Max:</b> -	<b>Factory setting:</b> -		
<b>Description:</b>	Displays the characteristics (A5E number and versions) of the power unit. [0]: A5E number xxxx (A5Exxxxxyyy) [1]: A5E number yyyy (A5Exxxxxyyy) [2]: File version (logistic) [3]: File version (fixed data) [4]: File version (calib data)				
<b>p3931</b>	<b>Options for electrical cabinets / Opt elec cabinet</b>				
	<b>Access level:</b> 3	<b>Calculated:</b> -	<b>Data type:</b> Unsigned32		
	<b>Can be changed:</b> T, U	<b>Scaling:</b> -	<b>Dynamic index:</b> -		
	<b>Unit group:</b> -	<b>Unit selection:</b> -	<b>Function diagram:</b> -		
	<b>Min:</b> -	<b>Max:</b> -	<b>Factory setting:</b> 0000 0000 0000 0000 bin		
<b>Description:</b>	Sets the options for the Power Module 330 (PM330).				
<b>Bit field:</b>	<b>Bit</b>	<b>Signal name</b>	<b>1 signal</b>	<b>0 signal</b>	<b>FP</b>
	00	Line filter	Yes	No	-
	01	Line Harmonics Filter	Yes	No	-
	02	du/dt filter compact Voltage Peak Limiter	Yes	No	-
	03	Motor reactor	Yes	No	-
	04	du/dt filter plus Voltage Peak Limiter	Yes	No	-
	05	w/o line reactor	Yes	No	-
	07	EmergOff button	Yes	No	-
	08	Emergency Stop category 0	Yes	No	-
	09	Emergency Stop category 1	Yes	No	-
	10	Emergency Stop category 1 24 V	Yes	No	-
	11	Braking Module (25 kW)	Yes	No	-
	12	Braking Module (50 kW)	Yes	No	-
<b>p3950</b>	<b>Service parameter / Serv par</b>				
	<b>Access level:</b> 3	<b>Calculated:</b> -	<b>Data type:</b> Unsigned16		
	<b>Can be changed:</b> C1, T, U	<b>Scaling:</b> -	<b>Dynamic index:</b> -		
	<b>Unit group:</b> -	<b>Unit selection:</b> -	<b>Function diagram:</b> -		
	<b>Min:</b> -	<b>Max:</b> -	<b>Factory setting:</b> -		
<b>Description:</b>	For service personnel only.				

7.3 Parameter list

**r3974 Drive unit status word / Drv\_unit ZSW**

<b>Access level:</b> 1	<b>Calculated:</b> -	<b>Data type:</b> Unsigned32
<b>Can be changed:</b> -	<b>Scaling:</b> -	<b>Dynamic index:</b> -
<b>Unit group:</b> -	<b>Unit selection:</b> -	<b>Function diagram:</b> -
<b>Min:</b>	<b>Max:</b>	<b>Factory setting:</b>
-	-	-

**Description:** Displays the status word for the drive unit.

<b>Bit field:</b>	<b>Bit</b>	<b>Signal name</b>	<b>1 signal</b>	<b>0 signal</b>	<b>FP</b>
	00	Software reset active	Yes	No	-
	01	Writing of parameters disabled as parameter save in progress	Yes	No	-
	02	Writing of parameters disabled as macro is running	Yes	No	-

**p3981 Acknowledge drive object faults / Ackn DO faults**

<b>Access level:</b> 3	<b>Calculated:</b> -	<b>Data type:</b> Unsigned8
<b>Can be changed:</b> T, U	<b>Scaling:</b> -	<b>Dynamic index:</b> -
<b>Unit group:</b> -	<b>Unit selection:</b> -	<b>Function diagram:</b> 8060
<b>Min:</b>	<b>Max:</b>	<b>Factory setting:</b>
0	1	0

**Description:** Setting to acknowledge all active faults of a drive object.

**NOTICE**  
Safety messages cannot be acknowledged using this parameter.

**Note**  
Parameter should be set from 0 to 1 to acknowledge.  
After acknowledgment, the parameter is automatically reset to 0.

**p3985 Master control mode selection / PcCtrl mode select**

<b>Access level:</b> 3	<b>Calculated:</b> -	<b>Data type:</b> Integer16
<b>Can be changed:</b> T, U	<b>Scaling:</b> -	<b>Dynamic index:</b> -
<b>Unit group:</b> -	<b>Unit selection:</b> -	<b>Function diagram:</b> -
<b>Min:</b>	<b>Max:</b>	<b>Factory setting:</b>
0	1	0

**Description:** Sets the mode to change over the master control / LOCAL mode.

**Value:**  
0: Change master control for STW1.0 = 0  
1: Change master control in operation

**⚠ DANGER**  
When changing the master control in operation, the drive can manifest undesirable behavior - e.g. it can accelerate up to another setpoint.

**r3986 Number of parameters / Param count**

<b>Access level:</b> 3	<b>Calculated:</b> -	<b>Data type:</b> Unsigned16
<b>Can be changed:</b> -	<b>Scaling:</b> -	<b>Dynamic index:</b> -
<b>Unit group:</b> -	<b>Unit selection:</b> -	<b>Function diagram:</b> -
<b>Min:</b>	<b>Max:</b>	<b>Factory setting:</b>
-	-	-

**Description:** Displays the number of parameters for this drive unit.  
The number comprises the device-specific and the drive-specific parameters.

---

<b>r3996[0...1]</b>	<b>Parameter write inhibit status / Par_write inhib st</b>		
	<b>Access level:</b> 3	<b>Calculated:</b> -	<b>Data type:</b> Unsigned8
	<b>Can be changed:</b> -	<b>Scaling:</b> -	<b>Dynamic index:</b> -
	<b>Unit group:</b> -	<b>Unit selection:</b> -	<b>Function diagram:</b> -
	<b>Min:</b>	<b>Max:</b>	<b>Factory setting:</b>
	-	-	-

**Description:** Displays whether writing to parameters is inhibited.  
r3996[0] = 0:  
Parameter write not inhibited.  
0 < r3996[0] < 100:  
Parameter write inhibited. The value shows how the calculations are progressing.

**Index:** [0] = Progress calculations  
[1] = Cause

**Note**

For index 1:  
Only for internal Siemens troubleshooting.

---



---

<b>r4022.0...3</b>	<b>CO/BO: PM330 digital inputs status / PM330 DI status</b>		
CUG120X_PN (PM330)	<b>Access level:</b> 3	<b>Calculated:</b> -	<b>Data type:</b> Unsigned32
	<b>Can be changed:</b> -	<b>Scaling:</b> -	<b>Dynamic index:</b> -
	<b>Unit group:</b> -	<b>Unit selection:</b> -	<b>Function diagram:</b> -
	<b>Min:</b>	<b>Max:</b>	<b>Factory setting:</b>
	-	-	-

**Description:** Displays the status of the digital inputs of the PM330 power unit.

<b>Bit field:</b>	<b>Bit</b>	<b>Signal name</b>	<b>1 signal</b>	<b>0 signal</b>	<b>FP</b>
	00	DI 0 (X9.3, external alarm)	High	Low	-
	01	DI 1 (X9.4, external fault)	High	Low	-
	02	DI 2 (X9.5, Emergency Off category 0)	High	Low	-
	03	DI 3 (X9.6, Emergency Off category 1)	High	Low	-

**Dependency:** See also: r4023

**Note**

DI: Digital Input

---



---

<b>r4023.0...3</b>	<b>CO/BO: PM330 digital inputs status inverted / PM330 DI stat inv</b>		
CUG120X_PN (PM330)	<b>Access level:</b> 3	<b>Calculated:</b> -	<b>Data type:</b> Unsigned32
	<b>Can be changed:</b> -	<b>Scaling:</b> -	<b>Dynamic index:</b> -
	<b>Unit group:</b> -	<b>Unit selection:</b> -	<b>Function diagram:</b> -
	<b>Min:</b>	<b>Max:</b>	<b>Factory setting:</b>
	-	-	-

**Description:** Displays the inverted status of the digital inputs of Power Module 330 (PM330).

<b>Bit field:</b>	<b>Bit</b>	<b>Signal name</b>	<b>1 signal</b>	<b>0 signal</b>	<b>FP</b>
	00	DI 0 (X9.3, external alarm)	High	Low	-
	01	DI 1 (X9.4, external fault)	High	Low	-
	02	DI 2 (X9.5, Emergency Off category 0)	High	Low	-
	03	DI 3 (X9.6, Emergency Off category 1)	High	Low	-

**Dependency:** See also: r4022

**Note**

DI: Digital Input

---

<b>r4047</b>		<b>PM330 digital outputs status / PM330 DO status</b>			
CUG120X_PN (PM330)	<b>Access level:</b> 3	<b>Calculated:</b> -	<b>Data type:</b> Unsigned32		
	<b>Can be changed:</b> -	<b>Scaling:</b> -	<b>Dynamic index:</b> -		
	<b>Unit group:</b> -	<b>Unit selection:</b> -	<b>Function diagram:</b> -		
	<b>Min:</b>	<b>Max:</b>	<b>Factory setting:</b>		
	-	-	-		
<b>Description:</b>	Displays the status of the digital outputs of Power Module 330 (PM330).				
<b>Bit field:</b>	<b>Bit</b>	<b>Signal name</b>	<b>1 signal</b>	<b>0 signal</b>	<b>FP</b>
	00	DO 0 (X9.8: enable signal UDC link charged)	High	Low	-
	01	DO 1 (X9.11/X9.12: main contactor control)	High	Low	-
	<b>Note</b>				
	DO: Digital Output				

<b>p4095</b>		<b>PM330 digital inputs simulation mode / PM330 DI sim_mode</b>			
CUG120X_PN (PM330)	<b>Access level:</b> 3	<b>Calculated:</b> -	<b>Data type:</b> Unsigned32		
	<b>Can be changed:</b> T, U	<b>Scaling:</b> -	<b>Dynamic index:</b> -		
	<b>Unit group:</b> -	<b>Unit selection:</b> -	<b>Function diagram:</b> -		
	<b>Min:</b>	<b>Max:</b>	<b>Factory setting:</b>		
	-	-	0000 bin		
<b>Description:</b>	Sets the simulation mode for digital inputs of the PM330 power unit.				
<b>Bit field:</b>	<b>Bit</b>	<b>Signal name</b>	<b>1 signal</b>	<b>0 signal</b>	<b>FP</b>
	00	DI 0 (X9.3, external alarm)	Simulation	Terminal eval	-
	01	DI 1 (X9.4, external fault)	Simulation	Terminal eval	-
	02	DI 2 (X9.5, Emergency Off category 0)	Simulation	Terminal eval	-
	03	DI 3 (X9.6, Emergency Off category 1)	Simulation	Terminal eval	-
<b>Dependency:</b>	The setpoint for the input signals is specified using p4096. See also: p4096				
	<b>Note</b>				
	This parameter is not saved when data is backed-up (p0971, p0977). DI: Digital Input				

<b>p4096</b>		<b>PM330 digital inputs simulation mode setpoint / PM330 DI sim setp</b>			
CUG120X_PN (PM330)	<b>Access level:</b> 3	<b>Calculated:</b> -	<b>Data type:</b> Unsigned32		
	<b>Can be changed:</b> T, U	<b>Scaling:</b> -	<b>Dynamic index:</b> -		
	<b>Unit group:</b> -	<b>Unit selection:</b> -	<b>Function diagram:</b> 2275		
	<b>Min:</b>	<b>Max:</b>	<b>Factory setting:</b>		
	-	-	0000 bin		
<b>Description:</b>	Sets the setpoint for the input signals in the digital input simulation mode of the PM330 power unit.				
<b>Bit field:</b>	<b>Bit</b>	<b>Signal name</b>	<b>1 signal</b>	<b>0 signal</b>	<b>FP</b>
	00	DI 0 (X9.3, external alarm)	High	Low	-
	01	DI 1 (X9.4, external fault)	High	Low	-
	02	DI 2 (X9.5, Emergency Off category 0)	High	Low	-
	03	DI 3 (X9.6, Emergency Off category 1)	High	Low	-
<b>Dependency:</b>	The simulation of a digital input is selected using p4095. See also: p4095				
	<b>Note</b>				
	This parameter is not saved when data is backed-up (p0971, p0977). DI: Digital Input				

<b>p5350[0...n]</b>	<b>Mot_temp_mod 1/3 boost factor at standstill / Standst boost_fact</b>		
	<b>Access level:</b> 2	<b>Calculated:</b> -	<b>Data type:</b> FloatingPoint32
	<b>Can be changed:</b> T, U	<b>Scaling:</b> -	<b>Dynamic index:</b> MDS, p0130
	<b>Unit group:</b> -	<b>Unit selection:</b> -	<b>Function diagram:</b> 8017
	<b>Min:</b> 1.0000	<b>Max:</b> 2.0000	<b>Factory setting:</b> 2.0000
<b>Description:</b>	<p>Sets the boost factor for the copper losses at standstill for motor temperature models 1 and 3.  The entered factor is active for speed <math>n = 0</math> [rpm].  This factor is linearly reduced down to 1 between speeds <math>n = 0 \dots 1</math> [rpm].  The following values are required to calculate the boost factor:  - stall current (<math>I_{L0}</math>, p0318, catalog value)  - thermal stall current (<math>I_{th0}</math>, catalog value)  The boost factor is calculated as follows:  - <math>p5350 = (I_{L0} / I_{th0})^2</math></p>		
<b>Dependency:</b>	<p>See also: p0612, p5390, p5391  See also: F07011, A07012, F07013, A07014</p>		
<b>NOTICE</b>			
<p>When selecting a catalog motor (p0301), this parameter is automatically pre-assigned and is write protected. Information in p0300 should be carefully observed when removing write protection.</p>			
<b>Note</b>			
<p>Temperature model 1 (I2t):  The following applies for firmware version &lt; 4.7 SP6 or p0612.8 = 0:  - parameter p5350 is not active. Internally, a fixed boost factor of 1.333 is used as basis for the calculation.  The following applies from firmware version 4.7 SP6 and p0612.8 = 1:  - parameter p5350 becomes active as described above.</p>			

<b>r5389.0...8</b>	<b>CO/BO: Mot_temp status word faults/alarms / Mot_temp ZSW F/A</b>				
	<b>Access level:</b> 2	<b>Calculated:</b> -	<b>Data type:</b> Unsigned16		
	<b>Can be changed:</b> -	<b>Scaling:</b> -	<b>Dynamic index:</b> -		
	<b>Unit group:</b> -	<b>Unit selection:</b> -	<b>Function diagram:</b> 8016		
	<b>Min:</b> -	<b>Max:</b> -	<b>Factory setting:</b> -		
<b>Description:</b>	Display and BICO output for faults and alarms of the motor temperature monitoring.				
<b>Bit field:</b>	<b>Bit</b>	<b>Signal name</b>	<b>1 signal</b>	<b>0 signal</b>	<b>FP</b>
	00	Motor temperature measurement fault active	Yes	No	-
	01	Motor temperature model fault active	Yes	No	-
	02	Encoder temperature measurement fault active	Yes	No	-
	04	Motor temperature measurement alarm active	Yes	No	-
	05	Motor temperature measurement alarm active	Yes	No	-
	08	Current reduction active	Yes	No	-
<b>Dependency:</b>	<p>See also: r0034, p0612, r0632  See also: F07011, A07012, A07910</p>				

7.3 Parameter list

**Note**

For bit 00, 04:

The motor temperature is measured using a temperature sensor (p0600, p0601). When the bit is set, a high temperature is identified, and a corresponding signal is additionally output.

For bit 01, 05:

The motor temperature is monitored based on a temperature model (p0612). When the bit is set, a high temperature is identified, and a corresponding signal is additionally output.

For bit 02:

The encoder temperature is measured using a temperature sensor. When the bit is set, a high temperature is identified, and a corresponding signal is additionally output.

For bit 08:

When reaching the motor temperature alarm threshold, reduction of the maximum current is set as response (p0610 = 1). When the bit is set, reduction of the maximum current is active.

p5390[0...n]

**Mot\_temp\_mod 1/3 alarm threshold / A thresh**

**Access level:** 2

**Calculated:** -

**Data type:** FloatingPoint32

**Can be changed:** T, U

**Scaling:** -

**Dynamic index:** MDS, p0130

**Unit group:** 21\_1

**Unit selection:** p0505

**Function diagram:** 8017

**Min:**

**Max:**

**Factory setting:**

0.0 [°C]

200.0 [°C]

110.0 [°C]

**Description:**

Sets the alarm threshold for monitoring the motor temperature for motor temperature models 1 and 3.

The stator winding temperature (r0632) is used to initiate the signal.

The following applies for temperature model 1 (I2t):

- only effective from firmware version 4.7 SP6 and p0612.8 = 1.
- Alarm A07012 is output after the alarm threshold is exceeded.

- when commissioning a catalog motor for the first time, the threshold value is copied from p0605 to p5390.

The following applies for temperature model 3:

- after the alarm threshold is exceeded, alarm A07012 is output and a calculated delay time (t = p5371/p5381) is started.

- if the delay time has expired and the alarm threshold has, in the meantime, not been fallen below, then fault F07011 is output.

**Dependency:**

See also: r0034, p0605, p0612, r0632, p5391

See also: F07011, A07012, F07013, A07014

**NOTICE**

When selecting a catalog motor (p0301), this parameter is automatically pre-assigned and is write protected. Information in p0300 should be carefully observed when removing write protection.

**Note**

The hysteresis is 2 K.

p5391[0...n]

**Mot\_temp\_mod 1/3 fault threshold / F thresh**

**Access level:** 2

**Calculated:** -

**Data type:** FloatingPoint32

**Can be changed:** T, U

**Scaling:** -

**Dynamic index:** MDS, p0130

**Unit group:** 21\_1

**Unit selection:** p0505

**Function diagram:** 8017

**Min:**

**Max:**

**Factory setting:**

0.0 [°C]

200.0 [°C]

120.0 [°C]

**Description:**

Sets the fault threshold for monitoring the motor temperature for motor temperature models 1 and 3.

Fault F07011 is output after the fault threshold is exceeded.

The stator winding temperature (r0632) is used to initiate the signal.

The following applies for temperature model 1 (I2t):

- only effective from firmware version 4.7 SP6 and p0612.8 = 1.

- when commissioning a catalog motor for the first time, the threshold value is copied from p0615 to p5391.



**Dependency:** See also: r0034, p0612, p0615, r0632, p5390  
See also: F07011, F07013, A07014

**NOTICE**

When selecting a catalog motor (p0301), this parameter is automatically pre-assigned and is write protected. Information in p0300 should be carefully observed when removing write protection.

**Note**

The hysteresis is 2 K.

**r5600****Pe energy-saving mode ID / Pe mode ID**

**Access level:** 3

**Calculated:** -

**Data type:** Integer16

**Can be changed:** -

**Scaling:** -

**Dynamic index:** -

**Unit group:** -

**Unit selection:** -

**Function diagram:** 2381, 2382

**Min:**

**Max:**

**Factory setting:**

0

255

-

**Description:**

Displays the PROFenergy mode ID of the effective energy-saving mode.

**Value:**

0: POWER OFF  
2: Energy-saving mode 2  
240: Operation  
255: Ready

**Note**

Pe: PROFenergy profiles

**p5602[0...1]****Pe energy-saving mode pause time minimal / Pe mod t\_pause min**

**Access level:** 3

**Calculated:** -

**Data type:** Unsigned32

**Can be changed:** T

**Scaling:** -

**Dynamic index:** -

**Unit group:** -

**Unit selection:** -

**Function diagram:** 2381

**Min:**

**Max:**

**Factory setting:**

300000 [ms]

4294967295 [ms]

[0] 300000 [ms]

[1] 480000 [ms]

**Description:**

Sets the minimum possible pause time for the energy-saving mode.

The value is the sum of the following times:

- Energy-saving mode transition time
- Operating state transition time regular
- Energy-saving mode, time of minimum stay

**Index:**

[0] = Reserved  
[1] = Mode 2

**Note**

It is not permissible that the value is less than the sum of the "energy-saving mode transition time" and the "operating state transition time" (system properties).

Pe: PROFenergy profiles

**p5606[0...1]****Pe energy-saving mode time of maximum stay / Pe t\_max\_stay**

**Access level:** 3

**Calculated:** -

**Data type:** Unsigned32

**Can be changed:** T

**Scaling:** -

**Dynamic index:** -

**Unit group:** -

**Unit selection:** -

**Function diagram:** 2381

**Min:**

**Max:**

**Factory setting:**

0 [ms]

4294967295 [ms]

4294967295 [ms]

**Description:**

Sets the time of maximum stay for the energy-saving mode.

7.3 Parameter list

**Index:** [0] = Reserved  
[1] = Mode 2

**Note**  
Pe: PROFlenergy profiles

**p5611 Pe energy-saving properties general / Pe properties gen**

<b>Access level:</b> 3	<b>Calculated:</b> -	<b>Data type:</b> Unsigned32
<b>Can be changed:</b> T	<b>Scaling:</b> -	<b>Dynamic index:</b> -
<b>Unit group:</b> -	<b>Unit selection:</b> -	<b>Function diagram:</b> 2381, 2382
<b>Min:</b> -	<b>Max:</b> -	<b>Factory setting:</b> 0000 bin

**Description:** Sets the general properties for energy-saving.

<b>Bit field:</b>	<b>Bit</b>	<b>Signal name</b>	<b>1 signal</b>	<b>0 signal</b>	<b>FP</b>
	00	Inhibit PROFlenergy control commands	Yes	No	-
	01	Drive initiates OFF1 when transitioning to energy-saving mode	Yes	No	-
	02	Trans to energy-saving mode from PROFIdrive state S3/4 poss	Yes	No	-

**Note**  
Pe: PROFlenergy profiles  
PROFIdrive state S4: operation

**p5612[0...1] Pe energy-saving properties mode-dependent / Pe properties mod**

<b>Access level:</b> 3	<b>Calculated:</b> -	<b>Data type:</b> Unsigned32
<b>Can be changed:</b> T	<b>Scaling:</b> -	<b>Dynamic index:</b> -
<b>Unit group:</b> -	<b>Unit selection:</b> -	<b>Function diagram:</b> -
<b>Min:</b> -	<b>Max:</b> -	<b>Factory setting:</b> [0] 0110 bin [1] 0000 bin

**Description:** Sets the mode-dependent properties for energy-saving.

**Index:** [0] = Reserved  
[1] = Mode 2

<b>Bit field:</b>	<b>Bit</b>	<b>Signal name</b>	<b>1 signal</b>	<b>0 signal</b>	<b>FP</b>
	00	Reserved	Yes	No	-

**Note**  
Pe: PROFlenergy profiles

**r5613.0...1 CO/BO: Pe energy-saving active/inactive / Pe save act/inact**

<b>Access level:</b> 3	<b>Calculated:</b> -	<b>Data type:</b> Unsigned8
<b>Can be changed:</b> -	<b>Scaling:</b> -	<b>Dynamic index:</b> -
<b>Unit group:</b> -	<b>Unit selection:</b> -	<b>Function diagram:</b> 2382
<b>Min:</b> -	<b>Max:</b> -	<b>Factory setting:</b> -

**Description:** Display and binector output for the state display PROFlenergy energy saving active or inactive.

<b>Bit field:</b>	<b>Bit</b>	<b>Signal name</b>	<b>1 signal</b>	<b>0 signal</b>	<b>FP</b>
	00	Pe active	Yes	No	-
	01	Pe inactive	Yes	No	-

**Note**

Bit 0 and bit 1 are inverse of one another.  
Pe: PROFInergy profiles

**p5614****BI: Pe set switching on inhibited signal source / Pe sw-on\_inh s\_src**

<b>Access level:</b> 3	<b>Calculated:</b> -	<b>Data type:</b> Unsigned32 / Binary
<b>Can be changed:</b> T	<b>Scaling:</b> -	<b>Dynamic index:</b> -
<b>Unit group:</b> -	<b>Unit selection:</b> -	<b>Function diagram:</b> 2382
<b>Min:</b>	<b>Max:</b>	<b>Factory setting:</b>
-	-	0

**Description:** Sets the signal source to set in the PROFIdrive state S1 "switching on inhibited".

**Dependency:** See also: r5613

**Note**

Pe: PROFInergy profiles

**r7758[0...19]****KHP Control Unit serial number / KHP CU ser\_no**

<b>Access level:</b> 3	<b>Calculated:</b> -	<b>Data type:</b> Unsigned8
<b>Can be changed:</b> -	<b>Scaling:</b> -	<b>Dynamic index:</b> -
<b>Unit group:</b> -	<b>Unit selection:</b> -	<b>Function diagram:</b> -
<b>Min:</b>	<b>Max:</b>	<b>Factory setting:</b>
-	-	-

**Description:** Displays the actual serial number of the Control Unit.  
The individual characters of the serial number are displayed in the ASCII code in the indices.  
For the commissioning software, the ASCII characters are displayed uncoded.

**Dependency:** See also: p7765, p7766, p7767, p7768

**NOTICE**

An ASCII table (excerpt) can be found, for example, in the chapter of parameters.

**Note**

KHP: Know-How Protection

**p7759[0...19]****KHP Control Unit reference serial number / KHP CU ref ser\_no**

<b>Access level:</b> 3	<b>Calculated:</b> -	<b>Data type:</b> Unsigned8
<b>Can be changed:</b> T	<b>Scaling:</b> -	<b>Dynamic index:</b> -
<b>Unit group:</b> -	<b>Unit selection:</b> -	<b>Function diagram:</b> -
<b>Min:</b>	<b>Max:</b>	<b>Factory setting:</b>
-	-	-

**Description:** Sets the reference serial number for the Control Unit.  
Using this parameter, if a Control Unit and/or a memory card is replaced at the end customer, the OEM can again adapt the project to the modified hardware.

**Dependency:** See also: p7765, p7766, p7767, p7768

**Note**

KHP: Know-How Protection

- the OEM may only change this parameter for the use case "Sending encrypted SINAMICS data".  
- SINAMICS only evaluates this parameter when powering up from the encrypted "Load into file system..." output or when powering up from the encrypted PS files. The evaluation is only made when know-how protection and memory card copy protection have been activated.

**r7760.0...12**      **CO/BO: Write protection/know-how protection status / Wr\_prot/KHP stat**

<b>Access level:</b> 3	<b>Calculated:</b> -	<b>Data type:</b> Unsigned16
<b>Can be changed:</b> -	<b>Scaling:</b> -	<b>Dynamic index:</b> -
<b>Unit group:</b> -	<b>Unit selection:</b> -	<b>Function diagram:</b> -
<b>Min:</b>	<b>Max:</b>	<b>Factory setting:</b>
-	-	-

**Description:** Displays the status for the write protection and know-how protection.

<b>Bit field:</b>	<b>Bit</b>	<b>Signal name</b>	<b>1 signal</b>	<b>0 signal</b>	<b>FP</b>
	00	Write protection active	Yes	No	-
	01	Know-how protection active	Yes	No	-
	02	Know-how protection temporarily withdrawn	Yes	No	-
	03	Know-how protection cannot be deactivated	Yes	No	-
	04	Extended copy protection is active	Yes	No	-
	05	Basic copy protection is active	Yes	No	-
	06	Trace and measuring functions for diagnostic purposes active	Yes	No	-
	12	Reserved Siemens	Yes	No	-

**Dependency:** See also: p7761, p7765, p7766, p7767, p7768

**Note**

KHP: Know-How Protection

For bit 00:

Write protection can be activated/deactivated via p7761 on the Control Unit.

For bit 01:

The know-how protection can be activated by entering a password (p7766 ... p7768).

For bit 02:

If it has already been activated, know-how protection can be temporarily deactivated by entering the valid password in p7766. In this case, bit 1 = 0 and bit 2 = 1 offset.

For bit 03:

Know-how protection cannot be deactivated, as p7766 is not entered in the OEM exception list (only the factory setting is possible). This bit is only set if know-how protection is active (bit 1 = 1) and p7766 has not been entered in the OEM exception list.

For bit 04:

When know-how protection has been activated, the contents of the memory card (parameter and DCC data) can be additionally protected against being used with other memory cards/Control Units. This bit is only set if know-how protection is active and p7765 bit 00 is set.

For bit 05:

When know-how protection has been activated, the contents of the memory card (parameter and DCC data) can be additionally protected against being used with other memory cards. This bit is only set if know-how protection is active and in p7765 bit 01 is set and not bit 00.

For bit 06:

When know-how protection is activated, the drive data can be traced using the device trace function. This bit is only set if know-how protection is active and in p7765.2 is set.

**p7761**      **Write protection / Write protection**

<b>Access level:</b> 3	<b>Calculated:</b> -	<b>Data type:</b> Integer16
<b>Can be changed:</b> T, U	<b>Scaling:</b> -	<b>Dynamic index:</b> -
<b>Unit group:</b> -	<b>Unit selection:</b> -	<b>Function diagram:</b> -
<b>Min:</b>	<b>Max:</b>	<b>Factory setting:</b>
0	1	0

**Description:** Setting for activating/deactivating the write protection for adjustable parameters.

**Value:**

0:	Deactivate write protection
1:	Activate write protection

**Dependency:** See also: r7760

**Note**

Parameters with the "WRITE\_NO\_LOCK" attributes are excluded from the write protection.

**p7762 Write protection multi-master fieldbus system access behavior / Fieldbus acc\_behav**

<b>Access level:</b> 3	<b>Calculated:</b> -	<b>Data type:</b> Integer16
<b>Can be changed:</b> T, U	<b>Scaling:</b> -	<b>Dynamic index:</b> -
<b>Unit group:</b> -	<b>Unit selection:</b> -	<b>Function diagram:</b> -
<b>Min:</b> 0	<b>Max:</b> 1	<b>Factory setting:</b> 0

**Description:** Sets the behavior for write protection when accessing via multi-master fieldbus systems (e.g. CAN, BACnet).

**Value:**  
0: Write access independent of p7761  
1: Write access dependent on p7761

**Dependency:** See also: r7760, p7761

**p7763 KHP OEM exception list number of indices for p7764 / KHP OEM qty p7764**

<b>Access level:</b> 3	<b>Calculated:</b> -	<b>Data type:</b> Unsigned16
<b>Can be changed:</b> T, U	<b>Scaling:</b> -	<b>Dynamic index:</b> -
<b>Unit group:</b> -	<b>Unit selection:</b> -	<b>Function diagram:</b> -
<b>Min:</b> 1	<b>Max:</b> 500	<b>Factory setting:</b> 1

**Description:** Sets the number of parameters for the OEM exception list (p7764[0...n]).  
p7764[0...n], with n = p7763 - 1

**Dependency:** See also: p7764

**Note**

KHP: Know-How Protection

Even if know-how protection is set, parameters in this list can be read and written to.

**p7764[0...n] KHP OEM exception list / KHP OEM excep list**

<b>Access level:</b> 3	<b>Calculated:</b> -	<b>Data type:</b> Unsigned16
<b>Can be changed:</b> T, U	<b>Scaling:</b> -	<b>Dynamic index:</b> p7763
<b>Unit group:</b> -	<b>Unit selection:</b> -	<b>Function diagram:</b> -
<b>Min:</b> 0	<b>Max:</b> 65535	<b>Factory setting:</b> [0] 7766 [1...499] 0

**Description:** OEM exception list (p7764[0...n]) for setting parameters that should be excluded from know-how protection.  
p7764[0...n], with n = p7763 - 1

**Dependency:** The number of indices depends on p7763.  
See also: p7763

**Note**

KHP: Know-How Protection

Even if know-how protection is set, parameters in this list can be read and written to.

**p7765 KHP configuration / KHP config**

<b>Access level:</b> 3	<b>Calculated:</b> -	<b>Data type:</b> Unsigned16
<b>Can be changed:</b> T, U	<b>Scaling:</b> -	<b>Dynamic index:</b> -
<b>Unit group:</b> -	<b>Unit selection:</b> -	<b>Function diagram:</b> -
<b>Min:</b> -	<b>Max:</b> -	<b>Factory setting:</b> 0000 bin

7.3 Parameter list

**Description:** Configuration settings for know-how protection.  
 For bit 00, 01:  
 When KHP is activated, this means that the OEM can define whether the parameters and DCC data encrypted on the memory card should be protected before using on other memory cards/Control Units.  
 For bit 02:  
 This means that the OEM can define whether it is possible or not to trace the drive data using the device trace function although KHP is activated.

**Bit field:**

Bit	Signal name	1 signal	0 signal	FP
00	Extended copy protection - linked to the memory card and CU	Yes	No	-
01	Basic copy protection - linked to the memory card	Yes	No	-
02	Permit trace and measuring functions for diagnostic purposes	Yes	No	-

**Dependency:** See also: p7766, p7767, p7768

---

**Note**  
 KHP: Know-How Protection  
 For copy protection, the serial numbers of the memory card and/or Control Unit are checked.  
 The memory card copy protection and preventing data to be traced are only effective when the know-how protection has been activated.  
 For bit 00, 01:  
 If both bits are inadvertently set to 1 (e.g. at the BOP-2), then the setting of bit 0 applies.  
 There is no copy protection if both bits are set to 0.

---

**p7766[0...29] KHP password input / KHP passw input**

<b>Access level:</b> 3	<b>Calculated:</b> -	<b>Data type:</b> Unsigned16
<b>Can be changed:</b> T, U	<b>Scaling:</b> -	<b>Dynamic index:</b> -
<b>Unit group:</b> -	<b>Unit selection:</b> -	<b>Function diagram:</b> -
<b>Min:</b> -	<b>Max:</b> -	<b>Factory setting:</b> -

**Description:** Sets the password for know-how protection.  
 Example of a password:  
 123aBc = 49 50 51 97 66 99 dec (ASCII characters)  
 [0] = character 1 (e.g. 49 dec)  
 [1] = character 2 (e.g. 50 dec)  
 ...  
 [5] = character 6 (e.g. 99 dec)  
 [29] = 0 dec (completes the entry)

**Dependency:** See also: p7767, p7768

**NOTICE**

An ASCII table (excerpt) can be found, for example, in the chapter of parameters.  
 When using the commissioning software, the password should be entered using the associated dialogs.  
 The following rules apply when entering the password:  
 - password entry must start with p7766[0].  
 - no gaps are permissible in the password.  
 - entering a password is completed when writing to p7766[29] (p7766[29] = 0 for passwords less than 30 characters).

**Note**  
 KHP: Know-How Protection  
 When reading, p7766[0...29] = 42 dec (ASCII character = "\*\*\*") is displayed.  
 Parameters with the "KHP\_WRITE\_NO\_LOCK" attribute are not involved in the know-how protection.  
 Parameters with the "KHP\_ACTIVE\_READ" attribute can be read even when know-how protection is activated.

<b>p7767[0...29]</b>	<b>KHP password new / KHP passw new</b>	<b>Access level:</b> 3	<b>Calculated:</b> -	<b>Data type:</b> Unsigned16
		<b>Can be changed:</b> T, U	<b>Scaling:</b> -	<b>Dynamic index:</b> -
		<b>Unit group:</b> -	<b>Unit selection:</b> -	<b>Function diagram:</b> -
		<b>Min:</b>	<b>Max:</b>	<b>Factory setting:</b>
		-	-	-
<b>Description:</b>	Sets the new password for know-how protection.			
<b>Dependency:</b>	See also: p7766, p7768			
	<b>Note</b>			
	KHP: Know-How Protection			
	When reading, p7767[0...29] = 42 dec (ASCII character = "*" ) is displayed.			
<b>p7768[0...29]</b>	<b>KHP password confirmation / KHP passw confirm</b>	<b>Access level:</b> 3	<b>Calculated:</b> -	<b>Data type:</b> Unsigned16
		<b>Can be changed:</b> T, U	<b>Scaling:</b> -	<b>Dynamic index:</b> -
		<b>Unit group:</b> -	<b>Unit selection:</b> -	<b>Function diagram:</b> -
		<b>Min:</b>	<b>Max:</b>	<b>Factory setting:</b>
		-	-	-
<b>Description:</b>	Confirms the new password for know-how protection.			
<b>Dependency:</b>	See also: p7766, p7767			
	<b>Note</b>			
	KHP: Know-How Protection			
	When reading, p7768[0...29] = 42 dec (ASCII character = "*" ) is displayed.			
<b>p7769[0...20]</b>	<b>KHP memory card reference serial number / KHP mem ref ser_no</b>	<b>Access level:</b> 3	<b>Calculated:</b> -	<b>Data type:</b> Unsigned8
		<b>Can be changed:</b> T	<b>Scaling:</b> -	<b>Dynamic index:</b> -
		<b>Unit group:</b> -	<b>Unit selection:</b> -	<b>Function diagram:</b> -
		<b>Min:</b>	<b>Max:</b>	<b>Factory setting:</b>
		-	-	-
<b>Description:</b>	Sets the reference serial number for the memory card.			
	Using this parameter, if a Control Unit and/or a memory card is replaced at the end customer, the OEM can again adapt the project to the modified hardware.			
<b>Dependency:</b>	See also: p7765, p7766, p7767, p7768			
	<b>Note</b>			
	KHP: Know-How Protection			
	- the OEM may only change this parameter for the use case "Sending encrypted SINAMICS data".			
	- SINAMICS only evaluates this parameter when powering up from the encrypted "Load into file system..." output or when powering up from the encrypted PS files. The evaluation is only made when know-how protection and memory card copy protection have been activated.			
<b>p7775</b>	<b>NVRAM data backup/import/delete / NVRAM backup</b>	<b>Access level:</b> 3	<b>Calculated:</b> -	<b>Data type:</b> Integer16
		<b>Can be changed:</b> C1, T, U	<b>Scaling:</b> -	<b>Dynamic index:</b> -
		<b>Unit group:</b> -	<b>Unit selection:</b> -	<b>Function diagram:</b> -
		<b>Min:</b>	<b>Max:</b>	<b>Factory setting:</b>
		0	17	0

7.3 Parameter list

**Description:** Setting to backup/import/delete NVRAM data.  
 NVRAM data are non-volatile data in the device (e.g. fault buffer).  
 For NVRAM data actions, the following data are excluded:  
 - crash diagnostics  
 - CU operating hours counter  
 - CU temperature  
 - safety logbook

**Value:**

- 0: Inactive
- 1: NVRAM data backup to memory card
- 2: Import NVRAM data from the memory card
- 3: Delete NVRAM data in the device
- 10: Error when clearing
- 11: Error when backing up, memory card not available
- 12: Error when backing up, insufficient memory space
- 13: Error when backing up
- 14: Error when importing, memory card not available
- 15: Error when importing, checksum error
- 16: Error when importing, no NVRAM data available
- 17: Error when importing

**NOTICE**  
 For value = 2, 3:  
 These actions are only possible when pulses are inhibited.

**Note**  
 After the action has been successfully completed, the parameter is automatically set to zero.  
 The actions importing and deleting NVRAM data immediately initiate a warm restart.  
 If the procedure was not successfully completed, then an appropriate fault value is displayed (p7775 >= 10).

---

**r7843[0...20]      Memory card serial number / Mem\_card ser.no**

<b>Access level:</b> 1	<b>Calculated:</b> -	<b>Data type:</b> Unsigned8
<b>Can be changed:</b> -	<b>Scaling:</b> -	<b>Dynamic index:</b> -
<b>Unit group:</b> -	<b>Unit selection:</b> -	<b>Function diagram:</b> -
<b>Min:</b>	<b>Max:</b>	<b>Factory setting:</b>
-	-	-

**Description:** Displays the actual serial number of the memory card.  
 The individual characters of the serial number are displayed in the ASCII code in the indices.

**NOTICE**  
 An ASCII table (excerpt) can be found, for example, in the chapter of parameters.



**Note**

Example: displaying the serial number for a memory card:

```
r7843[0] = 49 dec --> ASCII characters = "1" --> serial number, character 1
r7843[1] = 49 dec --> ASCII characters = "1" --> serial number, character 2
r7843[2] = 49 dec --> ASCII characters = "1" --> serial number, character 3
r7843[3] = 57 dec --> ASCII characters = "9" --> serial number, character 4
r7843[4] = 50 dec --> ASCII characters = "2" --> serial number, character 5
r7843[5] = 51 dec --> ASCII characters = "3" --> serial number, character 6
r7843[6] = 69 dec --> ASCII characters = "E" --> serial number, character 7
r7843[7] = 0 dec --> ASCII characters = " " --> serial number, character 8
...
r7843[19] = 0 dec --> ASCII characters = " " --> serial number, character 20
r7843[20] = 0 dec
Serial number = 111923E
```

**r7844[0...2]****Memory card/device memory firmware version / Mem\_crd/dev\_mem FW**

<b>Access level:</b> 2	<b>Calculated:</b> -	<b>Data type:</b> Unsigned32
<b>Can be changed:</b> -	<b>Scaling:</b> -	<b>Dynamic index:</b> -
<b>Unit group:</b> -	<b>Unit selection:</b> -	<b>Function diagram:</b> -
<b>Min:</b>	<b>Max:</b>	<b>Factory setting:</b>
-	-	-

**Description:**

Displays the version of the firmware stored on the memory medium of the drive device.

Depending on the drive device being used, the memory medium is a memory card, or an internal non-volatile device memory.

**Index:**

[0] = Internal  
 [1] = External  
 [2] = Parameter backup

**Note**

For index 0:

Displays the internal firmware version (e.g. 04402315).

This firmware version is the version of the memory card/device memory and not the CU firmware (r0018), however, normally they have the same versions.

For index 1:

Displays the external firmware version (e.g. 04040000 -> 4.4).

For automation systems with SINAMICS Integrated this is the runtime version of the automation system.

For index 2:

Displays the internal firmware version of the parameter backup.

With this CU firmware version, the parameter backup was saved, which was used when powering up.

**r7903****Hardware sampling times still assignable / HW t\_samp free**

<b>Access level:</b> 3	<b>Calculated:</b> -	<b>Data type:</b> Unsigned16
<b>Can be changed:</b> -	<b>Scaling:</b> -	<b>Dynamic index:</b> -
<b>Unit group:</b> -	<b>Unit selection:</b> -	<b>Function diagram:</b> -
<b>Min:</b>	<b>Max:</b>	<b>Factory setting:</b>
-	-	-

**Description:**

Displays the number of hardware sampling times that can still be assigned.

These free sampling times can be used by OA applications such as DCC or FBLOCKS.

**Note**

OA: Open Architecture

<b>p8400[0...2]</b>	<b>RTC time / RTC time</b>	<b>Calculated:</b> -	<b>Data type:</b> Unsigned16
	<b>Access level:</b> 3	<b>Scaling:</b> -	<b>Dynamic index:</b> -
	<b>Can be changed:</b> T, U	<b>Unit selection:</b> -	<b>Function diagram:</b> -
	<b>Unit group:</b> -	<b>Max:</b>	<b>Factory setting:</b>
	<b>Min:</b>	59	0
	0		
<b>Description:</b>	Sets and displays the time on the real-time clock in hours, minutes, and seconds. The time is stored in the internal clock block in the drive and continues to run even if the supply voltage for the Control Unit is interrupted (for approx. 5 days).		
<b>Index:</b>	[0] = Hour (0 ... 23) [1] = Minute (0 ... 59) [2] = Second (0 ... 59)		
	<b>Note</b> The time from p8400 and p8401 is used to display the fault and alarm times. When displaying the fault time and alarm time, the switchover to daylight saving time is not taken into account. The parameter is not reset when the factory setting is restored (p0010 = 30, p0970). The time is entered and displayed in 24-hour format. RTC: Real-time clock		
<b>p8401[0...2]</b>	<b>RTC date / RTC date</b>	<b>Calculated:</b> -	<b>Data type:</b> Unsigned16
	<b>Access level:</b> 3	<b>Scaling:</b> -	<b>Dynamic index:</b> -
	<b>Can be changed:</b> T, U	<b>Unit selection:</b> -	<b>Function diagram:</b> -
	<b>Unit group:</b> -	<b>Max:</b>	<b>Factory setting:</b>
	<b>Min:</b>	9999	[0] 1
	0		[1] 1
			[2] 1970
<b>Description:</b>	Sets and displays the date on the real-time clock in year, month, and day. The date is stored in the internal clock block in the drive and continues to run even if the supply voltage for the Control Unit is interrupted (for approx. 5 days).		
<b>Recommendation:</b>	When the date is set as an index, the day should always be written last because, if a date is invalid, the day is always corrected to the last valid day in that particular month of the year.		
<b>Index:</b>	[0] = Day (1 ... 31) [1] = Month (1 ... 12) [2] = Year (YYYY)		
	<b>Note</b> The time from p8400 and p8401 is used to display the fault and alarm times. When displaying the fault time and alarm time, the switchover to daylight saving time is not taken into account. The parameter is not reset when the factory setting is restored (p0010 = 30, p0970). RTC: Real-time clock		

---

<b>p8402[0...8]</b>	<b>RTC daylight saving time setting / RTC DST</b>		
<b>Access level:</b> 3	<b>Calculated:</b> -	<b>Data type:</b> Unsigned16	
<b>Can be changed:</b> T, U	<b>Scaling:</b> -	<b>Dynamic index:</b> -	
<b>Unit group:</b> -	<b>Unit selection:</b> -	<b>Function diagram:</b> -	
<b>Min:</b> 0	<b>Max:</b> 23	<b>Factory setting:</b>	
		[0] 0	
		[1] 3	
		[2] 6	
		[3] 7	
		[4] 2	
		[5] 10	
		[6] 6	
		[7] 7	
		[8] 3	

**Description:** Setting the daylight saving time.  
The factory setting corresponds to the time change for central european summer time (CEST). You only have to set p8402[0] = 1 to activate CEST.

**Index:**  
[0] = Difference (0 ... 3 hours)  
[1] = Start of month (1 ... 12)  
[2] = Start of the week of the month (1 ... 4, 6)  
[3] = Start of weekday (1 ... 7)  
[4] = Start of hour (0 ... 23)  
[5] = End of month (1 ... 12)  
[6] = End of the week of the month (1 ... 4, 6)  
[7] = End of weekday (1 ... 7)  
[8] = End of hour (0 ... 23)

**Note**

The switchover to daylight saving time only effects the RTC and DTC parameters (p8400 ... p8433).  
When displaying the fault time and alarm time, the switchover to daylight saving time is not taken into account.  
There must be at least two months between the start and end of daylight saving time.

For index 0:

0: daylight saving time switchover deactivated  
1 ... 3: time difference

For indices 1 and 5:

1 = January, ... , 12 = December

For indices 2 and 6:

1 = from the 1st to the 7th of the month  
2 = from the 8th to the 14th of the month  
3 = from the 15th to the 21st of the month  
4 = from the 22nd to the 28th of the month  
6 = the last 7 days of the month

For indices 3 and 7:

1 = Monday, ... , 7 = Sunday

---

<b>r8403</b>	<b>RTC actual daylight saving time difference / RTC act DST</b>		
<b>Access level:</b> 3	<b>Calculated:</b> -	<b>Data type:</b> Unsigned16	
<b>Can be changed:</b> -	<b>Scaling:</b> -	<b>Dynamic index:</b> -	
<b>Unit group:</b> -	<b>Unit selection:</b> -	<b>Function diagram:</b> -	
<b>Min:</b> -	<b>Max:</b> -	<b>Factory setting:</b> -	

**Description:** Displays the actual time difference in hours for the daylight saving time

7.3 Parameter list

**Note**

The value is 0, if daylight saving time has not been defined using p8402.  
 If it is presently daylight saving time according to what is defined in p8402, then the parameter indicates the time difference between daylight saving time and normal time (p8402[0]).

<b>r8404</b>	<b>RTC weekday / RTC weekday</b>		
	<b>Access level:</b> 3	<b>Calculated:</b> -	<b>Data type:</b> Integer16
	<b>Can be changed:</b> -	<b>Scaling:</b> -	<b>Dynamic index:</b> -
	<b>Unit group:</b> -	<b>Unit selection:</b> -	<b>Function diagram:</b> -
	<b>Min:</b>	<b>Max:</b>	<b>Factory setting:</b>
	1	7	-
<b>Description:</b>	Displays the weekday on the real-time clock.		
<b>Value:</b>	1: Monday 2: Tuesday 3: Wednesday 4: Thursday 5: Friday 6: Saturday 7: Sunday		

**Note**

RTC: Real-time clock

<b>p8405</b>	<b>Activate/deactivate RTC alarm A01098 / RTC A01098 act</b>		
	<b>Access level:</b> 3	<b>Calculated:</b> -	<b>Data type:</b> Integer16
	<b>Can be changed:</b> T	<b>Scaling:</b> -	<b>Dynamic index:</b> -
	<b>Unit group:</b> -	<b>Unit selection:</b> -	<b>Function diagram:</b> -
	<b>Min:</b>	<b>Max:</b>	<b>Factory setting:</b>
	0	1	1
<b>Description:</b>	Sets whether the real-time clock outputs an alarm if the time is not synchronized (e.g. if the power supply was switched off for an extended period).		
<b>Value:</b>	0: Alarm A01098 deactivated 1: Alarm A01098 activated		
<b>Dependency:</b>	See also: A01098		

**Note**

RTC: Real-time clock

<b>p8409</b>	<b>RTC DTC activation / RTC DTC act</b>		
	<b>Access level:</b> 3	<b>Calculated:</b> -	<b>Data type:</b> Integer16
	<b>Can be changed:</b> T, U	<b>Scaling:</b> -	<b>Dynamic index:</b> -
	<b>Unit group:</b> -	<b>Unit selection:</b> -	<b>Function diagram:</b> -
	<b>Min:</b>	<b>Max:</b>	<b>Factory setting:</b>
	0	1	1

<b>Description:</b>	Sets the activation/deactivation of the parameters for timers DTC1, DTC2, DTC3. For p8409 = 0, the following applies: DTC1 parameters p8410, p8411, p8412 are inactive and can be set. Binector output r8413.0 = 0. DTC2 parameters p8420, p8421, p8422 are inactive and can be set. Binector output r8423.0 = 0. DTC3 parameters p8430, p8431, p8432 are inactive and can be set. Binector output r8433.0 = 0. For p8409 = 1, the following applies: DTC1 parameters p8410, p8411, p8412 are active and cannot be set. Binector outputs r8413 are active. DTC2 parameters p8420, p8421, p8422 are active and cannot be set. Binector outputs r8423 are active. DTC3 parameters p8430, p8431, p8432 are active and cannot be set. Binector outputs r8433 are active.
<b>Value:</b>	0: DTC inactive and can be set 1: DTC active and cannot be set
<b>Dependency:</b>	See also: p8410, p8411, p8412, r8413, p8420, p8421, p8422, r8423, p8430, p8431, p8432, r8433

**Note**

DTC: Digital Time Clock (timer)  
RTC: Real-time clock

<b>p8410[0...6]</b>	<b>RTC DTC1 weekday of activation / RTC DTC1 day act</b>	<b>Access level:</b> 3	<b>Calculated:</b> -	<b>Data type:</b> Integer16
		<b>Can be changed:</b> T	<b>Scaling:</b> -	<b>Dynamic index:</b> -
		<b>Unit group:</b> -	<b>Unit selection:</b> -	<b>Function diagram:</b> -
		<b>Min:</b> 0	<b>Max:</b> 1	<b>Factory setting:</b> 0

<b>Description:</b>	Sets the weekday on which timer 1 is activated (DTC1). The switch-on/off time is set in p8411/p8412 and the result displayed via binector output r8413.
<b>Value:</b>	0: Weekday deactivated 1: Weekday activated
<b>Index:</b>	[0] = Monday [1] = Tuesday [2] = Wednesday [3] = Thursday [4] = Friday [5] = Saturday [6] = Sunday
<b>Dependency:</b>	See also: p8409, p8411, p8412, r8413

**NOTICE**

This parameter can only be changed when p8409 = 0.

**Note**

DTC: Digital Time Clock (timer)  
RTC: Real-time clock

<b>p8411[0...1]</b>	<b>RTC DTC1 switch-on time / RTC DTC1 t_ON</b>	<b>Access level:</b> 3	<b>Calculated:</b> -	<b>Data type:</b> Unsigned16
		<b>Can be changed:</b> T	<b>Scaling:</b> -	<b>Dynamic index:</b> -
		<b>Unit group:</b> -	<b>Unit selection:</b> -	<b>Function diagram:</b> -
		<b>Min:</b> 0	<b>Max:</b> 59	<b>Factory setting:</b> 0

<b>Description:</b>	Sets the switch-on time in hours and minutes for time switch 1 (DTC1). BO: r8413 = 1 signal: The condition for the set weekday (p8410) and switch-on time has been fulfilled.
---------------------	---

7.3 Parameter list

**Index:** [0] = Hour (0 ... 23)  
 [1] = Minute (0 ... 59)

**Dependency:** See also: p8409, p8410, r8413

**NOTICE**  
 This parameter can only be changed when p8409 = 0.

**Note**  
 DTC: Digital Time Clock (timer)  
 RTC: Real-time clock

**p8412[0...1]      RTC DTC1 off time / RTC DTC1 t\_OFF**

<b>Access level:</b> 3	<b>Calculated:</b> -	<b>Data type:</b> Unsigned16
<b>Can be changed:</b> T	<b>Scaling:</b> -	<b>Dynamic index:</b> -
<b>Unit group:</b> -	<b>Unit selection:</b> -	<b>Function diagram:</b> -
<b>Min:</b> 0	<b>Max:</b> 59	<b>Factory setting:</b> 0

**Description:** Sets the switch-off time in hours and minutes for time switch 1 (DTC1).  
 BO: r8413 = 0 signal:  
 The condition for the set weekday (p8410) and switch-off time has been fulfilled.

**Index:** [0] = Hour (0 ... 23)  
 [1] = Minute (0 ... 59)

**Dependency:** See also: p8409, p8410, r8413

**NOTICE**  
 This parameter can only be changed when p8409 = 0.

**Note**  
 DTC: Digital Time Clock (timer)  
 RTC: Real-time clock

**r8413.0...1      BO: RTC DTC1 output / RTC DTC1 output**

<b>Access level:</b> 3	<b>Calculated:</b> -	<b>Data type:</b> Unsigned16
<b>Can be changed:</b> -	<b>Scaling:</b> -	<b>Dynamic index:</b> -
<b>Unit group:</b> -	<b>Unit selection:</b> -	<b>Function diagram:</b> -
<b>Min:</b> -	<b>Max:</b> -	<b>Factory setting:</b> -

**Description:** Display and binector output for the output of time switch 1 (DTC1).  
 Where a weekday is deactivated, the following applies (p8410):  
 - the binector output for this timer is inactive (r8413.0 = 0).  
 Where a weekday is activated, the following applies (p8410):  
 - the ON/OFF time setting (p8411, p8412) for this timer has an instant effect on the binector output (r8413).

Bit field:	Bit	Signal name	1 signal	0 signal	FP
	00	Timer on	Yes	No	-
	01	Timer ON negated	No	Yes	-

**Dependency:** See also: p8409, p8410, p8411, p8412

**NOTICE**  
 This parameter can only be changed when p8409 = 0.

**Note**  
 DTC: Digital Time Clock (timer)  
 RTC: Real-time clock

<b>p8420[0...6]</b>	<b>RTC DTC2 weekday of activation / RTC DTC2 day act</b>	<b>Access level:</b> 3	<b>Calculated:</b> -	<b>Data type:</b> Integer16
		<b>Can be changed:</b> T	<b>Scaling:</b> -	<b>Dynamic index:</b> -
		<b>Unit group:</b> -	<b>Unit selection:</b> -	<b>Function diagram:</b> -
		<b>Min:</b> 0	<b>Max:</b> 1	<b>Factory setting:</b> 0

**Description:** Sets the weekday on which timer 2 is activated (DTC2).  
The switch-on/off time is set in p8421/p8422 and the result displayed via binector output r8423.

**Value:**  
0: Weekday deactivated  
1: Weekday activated

**Index:**  
[0] = Monday  
[1] = Tuesday  
[2] = Wednesday  
[3] = Thursday  
[4] = Friday  
[5] = Saturday  
[6] = Sunday

**Dependency:** See also: p8409, p8421, p8422, r8423

**NOTICE**

This parameter can only be changed when p8409 = 0.

**Note**

DTC: Digital Time Clock (timer)  
RTC: Real-time clock

<b>p8421[0...1]</b>	<b>RTC DTC2 switch-on time / RTC DTC2 t_ON</b>	<b>Access level:</b> 3	<b>Calculated:</b> -	<b>Data type:</b> Unsigned16
		<b>Can be changed:</b> T	<b>Scaling:</b> -	<b>Dynamic index:</b> -
		<b>Unit group:</b> -	<b>Unit selection:</b> -	<b>Function diagram:</b> -
		<b>Min:</b> 0	<b>Max:</b> 59	<b>Factory setting:</b> 0

**Description:** Sets the switch on time in hours and minutes for time switch 2 (DTC2).  
BO: r8423 = 1 signal:  
The condition for the set weekday (p8420) and switch-on time has been fulfilled.

**Index:**  
[0] = Hour (0 ... 23)  
[1] = Minute (0 ... 59)

**Dependency:** See also: p8409, p8420, r8423

**NOTICE**

This parameter can only be changed when p8409 = 0.

**Note**

DTC: Digital Time Clock (timer)  
RTC: Real-time clock

<b>p8422[0...1]</b>	<b>RTC DTC2 off time / RTC DTC2 t_OFF</b>	<b>Access level:</b> 3	<b>Calculated:</b> -	<b>Data type:</b> Unsigned16
		<b>Can be changed:</b> T	<b>Scaling:</b> -	<b>Dynamic index:</b> -
		<b>Unit group:</b> -	<b>Unit selection:</b> -	<b>Function diagram:</b> -
		<b>Min:</b> 0	<b>Max:</b> 59	<b>Factory setting:</b> 0

7.3 Parameter list

**Description:** Sets the switch off time in hours and minutes for time switch 2 (DTC2).  
 BO: r8423 = 0 signal:  
 The condition for the set weekday (p8420) and switch-off time has been fulfilled.

**Index:** [0] = Hour (0 ... 23)  
 [1] = Minute (0 ... 59)

**Dependency:** See also: p8409, p8420, r8423

**NOTICE**  
 This parameter can only be changed when p8409 = 0.

**Note**  
 DTC: Digital Time Clock (timer)  
 RTC: Real-time clock

**r8423.0...1**      **BO: RTC DTC2 output / RTC DTC2 output**

<b>Access level:</b> 3	<b>Calculated:</b> -	<b>Data type:</b> Unsigned16
<b>Can be changed:</b> -	<b>Scaling:</b> -	<b>Dynamic index:</b> -
<b>Unit group:</b> -	<b>Unit selection:</b> -	<b>Function diagram:</b> -
<b>Min:</b>	<b>Max:</b>	<b>Factory setting:</b>
-	-	-

**Description:** Display and binector output for the output of timer 2 (DTC2).  
 Where a weekday is deactivated, the following applies (p8420):  
 - the binector output for this timer is inactive (r8423.0 = 0).  
 Where a weekday is activated, the following applies (p8420):  
 - the ON/OFF time setting (p8421, p8422) for this timer has an instant effect on the binector output (r8423).

**Bit field:**

Bit	Signal name	1 signal	0 signal	FP
00	Timer on	Yes	No	-
01	Timer ON negated	No	Yes	-

**Dependency:** See also: p8409, p8420, p8421, p8422

**NOTICE**  
 This parameter can only be changed when p8409 = 0.

**Note**  
 DTC: Digital Time Clock (timer)  
 RTC: Real-time clock

**p8430[0...6]**      **RTC DTC3 weekday of activation / RTC DTC3 day act**

<b>Access level:</b> 3	<b>Calculated:</b> -	<b>Data type:</b> Integer16
<b>Can be changed:</b> T	<b>Scaling:</b> -	<b>Dynamic index:</b> -
<b>Unit group:</b> -	<b>Unit selection:</b> -	<b>Function diagram:</b> -
<b>Min:</b>	<b>Max:</b>	<b>Factory setting:</b>
0	1	0

**Description:** Sets the weekday on which timer 3 is activated (DTC3).  
 The switch-on/off time is set in p8431/p8432 and the result displayed via binector output r8433.

**Value:**  
 0:            Weekday deactivated  
 1:            Weekday activated



**Index:** [0] = Monday  
 [1] = Tuesday  
 [2] = Wednesday  
 [3] = Thursday  
 [4] = Friday  
 [5] = Saturday  
 [6] = Sunday

**Dependency:** See also: p8409, p8431, p8432, r8433

**NOTICE**

This parameter can only be changed when p8409 = 0.

**Note**

DTC: Digital Time Clock (timer)

RTC: Real-time clock

**p8431[0...1] RTC DTC3 switch-on time / RTC DTC3 t\_ON**

<b>Access level:</b> 3	<b>Calculated:</b> -	<b>Data type:</b> Unsigned16
<b>Can be changed:</b> T	<b>Scaling:</b> -	<b>Dynamic index:</b> -
<b>Unit group:</b> -	<b>Unit selection:</b> -	<b>Function diagram:</b> -
<b>Min:</b> 0	<b>Max:</b> 59	<b>Factory setting:</b> 0

**Description:** Sets the switch on time in hours and minutes for timer 3 (DTC3).  
 BO: r8433 = 1 signal:  
 The condition for the set weekday (p8430) and switch-on time has been fulfilled.

**Index:** [0] = Hour (0 ... 23)  
 [1] = Minute (0 ... 59)

**Dependency:** See also: p8409, p8430, r8433

**NOTICE**

This parameter can only be changed when p8409 = 0.

**Note**

DTC: Digital Time Clock (timer)

RTC: Real-time clock

**p8432[0...1] RTC DTC3 off time / RTC DTC3 t\_OFF**

<b>Access level:</b> 3	<b>Calculated:</b> -	<b>Data type:</b> Unsigned16
<b>Can be changed:</b> T	<b>Scaling:</b> -	<b>Dynamic index:</b> -
<b>Unit group:</b> -	<b>Unit selection:</b> -	<b>Function diagram:</b> -
<b>Min:</b> 0	<b>Max:</b> 59	<b>Factory setting:</b> 0

**Description:** Sets the switch off time in hours and minutes for timer 3 (DTC3).  
 BO: r8433 = 0 signal:  
 The condition for the set weekday (p8430) and switch-off time has been fulfilled.

**Index:** [0] = Hour (0 ... 23)  
 [1] = Minute (0 ... 59)

**Dependency:** See also: p8409, p8430, r8433

**NOTICE**

This parameter can only be changed when p8409 = 0.

7.3 Parameter list

**Note**

DTC: Digital Time Clock (timer)  
 RTC: Real-time clock

r8433.0...1

**BO: RTC DTC3 output / RTC DTC3 output**

<b>Access level:</b> 3	<b>Calculated:</b> -	<b>Data type:</b> Unsigned16
<b>Can be changed:</b> -	<b>Scaling:</b> -	<b>Dynamic index:</b> -
<b>Unit group:</b> -	<b>Unit selection:</b> -	<b>Function diagram:</b> -
<b>Min:</b> -	<b>Max:</b> -	<b>Factory setting:</b> -

**Description:**

Display and binector output for the output of timer 3 (DTC3).  
 Where a weekday is deactivated, the following applies (p8430):  
 - the binector output for this timer is inactive (r8433.0 = 0).  
 Where a weekday is activated, the following applies (p8430):  
 - the ON/OFF time setting (p8431, p8432) for this timer has an instant effect on the binector output (r8433).

**Bit field:**

Bit	Signal name	1 signal	0 signal	FP
00	Timer on	Yes	No	-
01	Timer ON negated	No	Yes	-

**Dependency:**

See also: p8409, p8430, p8431, p8432

**NOTICE**

This parameter can only be changed when p8409 = 0.

**Note**

DTC: Digital Time Clock (timer)  
 RTC: Real-time clock

r8540.0...15

**BO: STW1 from IOP in the manual mode / STW1 IOP**

<b>Access level:</b> 3	<b>Calculated:</b> -	<b>Data type:</b> Unsigned16
<b>Can be changed:</b> -	<b>Scaling:</b> -	<b>Dynamic index:</b> -
<b>Unit group:</b> -	<b>Unit selection:</b> -	<b>Function diagram:</b> -
<b>Min:</b> -	<b>Max:</b> -	<b>Factory setting:</b> -

**Description:**

For the manual mode: the STW1 (control word 1) entered from the IOP is displayed.

**Bit field:**

Bit	Signal name	1 signal	0 signal	FP
00	ON/OFF1	Yes	No	-
01	OC / OFF2	Yes	No	-
02	OC / OFF3	Yes	No	-
03	Reserved	Yes	No	-
04	Reserved	Yes	No	-
05	Reserved	Yes	No	-
06	Reserved	Yes	No	-
07	Acknowledge fault	Yes	No	-
08	Jog bit 0	Yes	No	3030
09	Jog bit 1	Yes	No	3030
10	Reserved	Yes	No	-
11	Direction reversal (setpoint)	Yes	No	-
12	Reserved	Yes	No	-
13	Reserved	Yes	No	-
14	Reserved	Yes	No	-

15	Reserved	Yes	No	-
----	----------	-----	----	---

<b>r8541</b>	<b>CO: Speed setpoint from the IOP in the manual mode / n_set IOP</b>	<b>Access level:</b> 3	<b>Calculated:</b> -	<b>Data type:</b> FloatingPoint32
		<b>Can be changed:</b> -	<b>Scaling:</b> p2000	<b>Dynamic index:</b> -
		<b>Unit group:</b> 3_1	<b>Unit selection:</b> p0505	<b>Function diagram:</b> -
		<b>Min:</b> - [rpm]	<b>Max:</b> - [rpm]	<b>Factory setting:</b> - [rpm]
<b>Description:</b>	For the manual mode: the speed setpoint entered from the IOP is displayed.			
<b>p8542[0...15]</b>	<b>BI: Active STW1 in the BOP/IOP manual mode / STW1 act OP</b>	<b>Access level:</b> 3	<b>Calculated:</b> -	<b>Data type:</b> Unsigned32 / Binary
		<b>Can be changed:</b> T	<b>Scaling:</b> -	<b>Dynamic index:</b> -
		<b>Unit group:</b> -	<b>Unit selection:</b> -	<b>Function diagram:</b> -
		<b>Min:</b> -	<b>Max:</b> -	<b>Factory setting:</b>
				[0] 8540.0
				[1] 8540.1
				[2] 8540.2
				[3] 8540.3
				[4] 8540.4
				[5] 8540.5
				[6] 8540.6
				[7] 8540.7
				[8] 8540.8
				[9] 8540.9
				[10] 8540.10
				[11] 8540.11
				[12] 8540.12
				[13] 8540.13
				[14] 8540.14
				[15] 8540.15
<b>Description:</b>	For the manual mode: Setting of the signal sources for STW1 (control word 1).			
<b>Index:</b>	[0] = ON/OFF1 [1] = OC / OFF2 [2] = OC / OFF3 [3] = Enable operation [4] = Enable ramp-function generator [5] = Continue ramp-function generator [6] = Enable speed setpoint [7] = Acknowledge fault [8] = Jog bit 0 [9] = Jog bit 1 [10] = Master control by PLC [11] = Direction reversal (setpoint) [12] = Enable speed controller [13] = Motorized potentiometer raise [14] = Motorized potentiometer lower [15] = CDS bit 0			

<b>p8543</b>	<b>CI: Active speed setpoint in the BOP/IOP manual mode / N_act act OP</b>		
	<b>Access level:</b> 3	<b>Calculated:</b> -	<b>Data type:</b> Unsigned32 / FloatingPoint32
	<b>Can be changed:</b> T	<b>Scaling:</b> p2000	<b>Dynamic index:</b> -
	<b>Unit group:</b> -	<b>Unit selection:</b> -	<b>Function diagram:</b> -
	<b>Min:</b> -	<b>Max:</b> -	<b>Factory setting:</b> 8541[0]
<b>Description:</b>	For the manual mode: Sets the signal source for the speed setpoint.		
<b>p8552</b>	<b>IOP speed unit / IOP speed unit</b>		
	<b>Access level:</b> 3	<b>Calculated:</b> -	<b>Data type:</b> Integer16
	<b>Can be changed:</b> T	<b>Scaling:</b> -	<b>Dynamic index:</b> -
	<b>Unit group:</b> -	<b>Unit selection:</b> -	<b>Function diagram:</b> -
	<b>Min:</b> 1	<b>Max:</b> 2	<b>Factory setting:</b> 1
<b>Description:</b>	Sets the unit for displaying and entering speeds.		
<b>Value:</b>	1: Hz 2: rpm		
<b>p8558</b>	<b>BI: Select IOP manual mode / Sel IOP man mode</b>		
	<b>Access level:</b> 3	<b>Calculated:</b> -	<b>Data type:</b> Unsigned32 / Binary
	<b>Can be changed:</b> T, U	<b>Scaling:</b> -	<b>Dynamic index:</b> -
	<b>Unit group:</b> -	<b>Unit selection:</b> -	<b>Function diagram:</b> -
	<b>Min:</b> -	<b>Max:</b> -	<b>Factory setting:</b> 0
<b>r8570[0...39]</b>	<b>Macro drive object / Macro DO</b>		
	<b>Access level:</b> 1	<b>Calculated:</b> -	<b>Data type:</b> Unsigned32
	<b>Can be changed:</b> -	<b>Scaling:</b> -	<b>Dynamic index:</b> -
	<b>Unit group:</b> -	<b>Unit selection:</b> -	<b>Function diagram:</b> -
	<b>Min:</b> -	<b>Max:</b> -	<b>Factory setting:</b> -
<b>Description:</b>	Displays the macro file saved in the appropriate directory on the memory card/device memory.		
<b>Dependency:</b>	See also: p0015		
	<b>Note</b>		
	For a value = 9999999, the following applies: The read operation is still running.		
<b>r8585</b>	<b>Macro execution actual / Macro executed</b>		
	<b>Access level:</b> 3	<b>Calculated:</b> -	<b>Data type:</b> Unsigned16
	<b>Can be changed:</b> -	<b>Scaling:</b> -	<b>Dynamic index:</b> -
	<b>Unit group:</b> -	<b>Unit selection:</b> -	<b>Function diagram:</b> -
	<b>Min:</b> -	<b>Max:</b> -	<b>Factory setting:</b> -
<b>Description:</b>	Displays the macro currently being executed on the drive object.		
<b>Dependency:</b>	See also: p0015, p1000, r8570		

<b>p8805</b>	<b>Identification and maintenance 4 configuration / I&amp;M 4 config</b>		
	<b>Access level:</b> 3	<b>Calculated:</b> -	<b>Data type:</b> Integer16
	<b>Can be changed:</b> T, U	<b>Scaling:</b> -	<b>Dynamic index:</b> -
	<b>Unit group:</b> -	<b>Unit selection:</b> -	<b>Function diagram:</b> -
	<b>Min:</b> 0	<b>Max:</b> 1	<b>Factory setting:</b> 0
<b>Description:</b>	Sets the configuration for the content of identification and maintenance 4 (I&M 4, p8809).		
<b>Value:</b>	0: Standard value for I&M 4 (p8809) 1: User value for I&M 4 (p8809)		
<b>Dependency:</b>	For p8805 = 0, if the user writes at least one value in p8809[0...53], then p8805 is automatically set to = 1. When p8805 is reset = 0, then the content of the factory setting is set in p8809.		

**Note**

For p8805 = 0:  
PROFINET I&M 4 (p8809) contains the information for the SI change tracking.  
For p8805 = 1:  
PROFINET I&M 4 (p8809) contains the values written by the user.

<b>p8806[0...53]</b>	<b>Identification and Maintenance 1 / I&amp;M 1</b>		
	<b>Access level:</b> 3	<b>Calculated:</b> -	<b>Data type:</b> Unsigned8
	<b>Can be changed:</b> T, U	<b>Scaling:</b> -	<b>Dynamic index:</b> -
	<b>Unit group:</b> -	<b>Unit selection:</b> -	<b>Function diagram:</b> -
	<b>Min:</b> -	<b>Max:</b> -	<b>Factory setting:</b> -
<b>Description:</b>	Parameters for the PROFINET data set "Identification and Maintenance 1" (I&M 1). This information is known as "System identifier" and "Location identifier".		
<b>Dependency:</b>	See also: p8807, p8808		

**NOTICE**

Only characters belonging to the standard ASCII character set may be used (32 dec to 126 dec).

**Note**

An ASCII table (excerpt) can be found, for example, in the chapter of parameters.  
For p8806[0...31]:  
System identifier.  
For p8806[32...53]:  
Location identifier.

<b>p8807[0...15]</b>	<b>Identification and Maintenance 2 / I&amp;M 2</b>		
	<b>Access level:</b> 3	<b>Calculated:</b> -	<b>Data type:</b> Unsigned8
	<b>Can be changed:</b> T, U	<b>Scaling:</b> -	<b>Dynamic index:</b> -
	<b>Unit group:</b> -	<b>Unit selection:</b> -	<b>Function diagram:</b> -
	<b>Min:</b> -	<b>Max:</b> -	<b>Factory setting:</b> -
<b>Description:</b>	Parameters for the PROFINET data set "Identification and Maintenance 2" (I&M 2). This information is known as "Installation date".		
<b>Dependency:</b>	See also: p8806, p8808		

7.3 Parameter list

**Note**

An ASCII table (excerpt) can be found, for example, in the chapter of parameters.  
 For p8807[0...15]:  
 Dates of installation or first commissioning of the device with the following format options (ASCII):  
 YYYY-MM-DD  
 or  
 YYYY-MM-DD hh:mm  
 - YYYY: year  
 - MM: month 01 ... 12  
 - DD: day 01 ... 31  
 - hh: hours 00 ... 23  
 - mm: minutes 00 ... 59  
 Separators must be placed between the individual data, i.e. a hyphen '-', space ' ' and colon ':'.

<b>p8808[0...53]</b>	<b>Identification and Maintenance 3 / I&amp;M 3</b>		
	<b>Access level:</b> 3	<b>Calculated:</b> -	<b>Data type:</b> Unsigned8
	<b>Can be changed:</b> T, U	<b>Scaling:</b> -	<b>Dynamic index:</b> -
	<b>Unit group:</b> -	<b>Unit selection:</b> -	<b>Function diagram:</b> -
	<b>Min:</b>	<b>Max:</b>	<b>Factory setting:</b>
	-	-	

**Description:** Parameters for the PROFINET data set "Identification and Maintenance 3" (I&M 3).  
 This information is known as "Supplementary information".

**Dependency:** See also: p8806, p8807

**NOTICE**  
 Only characters belonging to the standard ASCII character set may be used (32 dec to 126 dec).

**Note**

An ASCII table (excerpt) can be found, for example, in the chapter of parameters.  
 For p8808[0...53]:  
 Any supplementary information and comments (ASCII).

<b>p8809[0...53]</b>	<b>Identification and Maintenance 4 / I&amp;M 4</b>		
	<b>Access level:</b> 3	<b>Calculated:</b> -	<b>Data type:</b> Unsigned8
	<b>Can be changed:</b> T, U	<b>Scaling:</b> -	<b>Dynamic index:</b> -
	<b>Unit group:</b> -	<b>Unit selection:</b> -	<b>Function diagram:</b> -
	<b>Min:</b>	<b>Max:</b>	<b>Factory setting:</b>
	0000 bin	1111 1111 bin	0000 bin

**Description:** Parameters for the PROFINET data set "Identification and Maintenance 4" (I&M 4).  
 This information is known as "Signature".

**Dependency:** This parameter is preassigned as standard (see note).  
 After writing information to p8809, p8805 is automatically set to = 1.  
 See also: p8805

**Note**

For p8805 = 0 (factory setting) the following applies:  
 Parameter p8809 contains the information described below.  
 For p8809[0...3]:  
 Contains the value from r9781[0] "SI change tracking checksum functional".  
 For p8809[4...7]:  
 Contains the value from r9782[0] "SI change tracking time stamp checksum functional".  
 For p8809[8...53]:  
 Reserved.

<b>r8859[0...7]</b>	<b>PROFINET identification data / PN ident data</b>		
	<b>Access level:</b> 3	<b>Calculated:</b> -	<b>Data type:</b> Unsigned16
	<b>Can be changed:</b> -	<b>Scaling:</b> -	<b>Dynamic index:</b> -
	<b>Unit group:</b> -	<b>Unit selection:</b> -	<b>Function diagram:</b> -
	<b>Min:</b>	<b>Max:</b>	<b>Factory setting:</b>
	-	-	-
<b>Description:</b>	Displays the PROFINET identification data		
<b>Index:</b>	[0] = Version interface structure [1] = Version interface driver [2] = Company (Siemens = 42) [3] = CB type [4] = Firmware version [5] = Firmware date (year) [6] = Firmware date (day/month) [7] = Firmware patch/hot fix		
	<b>Note</b>		
	Example:		
	r8859[0] = 100 --> version of the interface structure V1.00		
	r8859[1] = 111 --> version of the interface driver V1.11		
	r8859[2] = 42 --> SIEMENS		
	r8859[3] = 0		
	r8859[4] = 1300 --> first part, firmware version V13.00 (second part, see index 7)		
	r8859[5] = 2011 --> year 2011		
	r8859[6] = 2306 --> 23rd of June		
	r8859[7] = 1700 --> second part, firmware version (complete version: V13.00.17.00)		

<b>r8909</b>	<b>PN device ID / PN device ID</b>		
	<b>Access level:</b> 3	<b>Calculated:</b> -	<b>Data type:</b> Unsigned16
	<b>Can be changed:</b> -	<b>Scaling:</b> -	<b>Dynamic index:</b> -
	<b>Unit group:</b> -	<b>Unit selection:</b> -	<b>Function diagram:</b> -
	<b>Min:</b>	<b>Max:</b>	<b>Factory setting:</b>
	-	-	-
<b>Description:</b>	Displays the PROFINET Device ID. Every SINAMICS device type has its own PROFINET Device ID and its own PROFINET GSD.		
	<b>Note</b>		
	List of the SINAMICS Device IDs:		
	0501 hex: S120/S150		
	0504 hex: G130/G150		
	050A hex: DC MASTER		
	050C hex: MV		
	050F hex: G120P		
	0510 hex: G120C		
	0511 hex: G120 CU240E-2		
	0512 hex: G120D		
	0513 hex: G120 CU250S-2 Vector		
	0514 hex: G110M		

---

<b>p8920[0...239]</b>	<b>PN Name of Station / PN Name Stat</b>	<b>Access level:</b> 3	<b>Calculated:</b> -	<b>Data type:</b> Unsigned8
		<b>Can be changed:</b> T, U	<b>Scaling:</b> -	<b>Dynamic index:</b> -
		<b>Unit group:</b> -	<b>Unit selection:</b> -	<b>Function diagram:</b> -
		<b>Min:</b>	<b>Max:</b>	<b>Factory setting:</b>
		-	-	-

**Description:** Sets the station name for the onboard PROFINET interface on the Control Unit.  
The actual station name is displayed in r8930.

**Dependency:** See also: p8925, r8930

**Note**

An ASCII table (excerpt) can be found, for example, in the chapter of parameters.  
The interface configuration (p8920 and following) is activated with p8925.  
The parameter is not influenced by setting the factory setting.  
PN: PROFINET

---



---

<b>p8921[0...3]</b>	<b>PN IP address / PN IP addr</b>	<b>Access level:</b> 3	<b>Calculated:</b> -	<b>Data type:</b> Unsigned8
		<b>Can be changed:</b> T, U	<b>Scaling:</b> -	<b>Dynamic index:</b> -
		<b>Unit group:</b> -	<b>Unit selection:</b> -	<b>Function diagram:</b> -
		<b>Min:</b>	<b>Max:</b>	<b>Factory setting:</b>
		0	255	0

**Description:** Sets the IP address for the onboard PROFINET interface on the Control Unit.  
The actual IP address is displayed in r8931.

**Dependency:** See also: p8925, r8931

**Note**

The interface configuration (p8920 and following) is activated with p8925.  
The parameter is not influenced by setting the factory setting.

---



---

<b>p8922[0...3]</b>	<b>PN Default Gateway / PN Def Gateway</b>	<b>Access level:</b> 3	<b>Calculated:</b> -	<b>Data type:</b> Unsigned8
		<b>Can be changed:</b> T, U	<b>Scaling:</b> -	<b>Dynamic index:</b> -
		<b>Unit group:</b> -	<b>Unit selection:</b> -	<b>Function diagram:</b> -
		<b>Min:</b>	<b>Max:</b>	<b>Factory setting:</b>
		0	255	0

**Description:** Sets the default gateway for the onboard PROFINET interface on the Control Unit.  
The actual standard gateway is displayed in r8932.

**Dependency:** See also: p8925, r8932

**Note**

The interface configuration (p8920 and following) is activated with p8925.  
The parameter is not influenced by setting the factory setting.

---



---

<b>p8923[0...3]</b>	<b>PN Subnet Mask / PN Subnet Mask</b>	<b>Access level:</b> 3	<b>Calculated:</b> -	<b>Data type:</b> Unsigned8
		<b>Can be changed:</b> T, U	<b>Scaling:</b> -	<b>Dynamic index:</b> -
		<b>Unit group:</b> -	<b>Unit selection:</b> -	<b>Function diagram:</b> -
		<b>Min:</b>	<b>Max:</b>	<b>Factory setting:</b>
		0	255	0

**Description:** Sets the subnet mask for the onboard PROFINET interface on the Control Unit.  
The actual subnet mask is displayed in r8933.



**Dependency:** See also: p8925, r8933

**Note**

The interface configuration (p8920 and following) is activated with p8925.  
The parameter is not influenced by setting the factory setting.

**p8924****PN DHCP Mode / PN DHCP mode****Access level:** 3**Calculated:** -**Data type:** Integer16**Can be changed:** T, U**Scaling:** -**Dynamic index:** -**Unit group:** -**Unit selection:** -**Function diagram:** -**Min:****Max:****Factory setting:**

0

3

0

**Description:**

Sets the DHCP mode for the onboard PROFINET interface on the Control Unit.  
The actual DHCP mode is displayed in r8934.

**Value:**

0: DHCP off  
2: DHCP on, identification using MAC address  
3: DHCP on, identification via name of station

**Dependency:**

See also: p8925, r8934

**NOTICE**

When the DHCP mode is active (p8924 not equal to 0), then PROFINET communication via this interface is no longer possible!

**Note**

The interface configuration (p8920 and following) is activated with p8925.  
The active DHCP mode is displayed in parameter r8934.  
The parameter is not influenced by setting the factory setting.

**p8925****Activate PN interface configuration / PN IF config****Access level:** 3**Calculated:** -**Data type:** Integer16**Can be changed:** T, U**Scaling:** -**Dynamic index:** -**Unit group:** -**Unit selection:** -**Function diagram:** -**Min:****Max:****Factory setting:**

0

3

0

**Description:**

Setting to activate the interface configuration for the onboard PROFINET interface on the Control Unit.  
p8925 is automatically set to 0 at the end of the operation.

**Value:**

0: No function  
1: Reserved  
2: Activate and save configuration  
3: Delete configuration

**Dependency:**

See also: p8920, p8921, p8922, p8923, p8924

**NOTICE**

When the DHCP mode is active (p8924 > 0), then PROFINET communication via this interface is no longer possible!

**Note**

For p8925 = 2:  
The interface configuration (p8920 and following) is saved and activated after the next POWER ON.  
For p8925 = 3:  
The factory setting of the interface configuration is loaded after the next POWER ON.

7.3 Parameter list

---

<b>r8930[0...239]</b>	<b>PN Name of Station actual / PN Name Stat act</b>		
<b>Access level:</b> 3	<b>Calculated:</b> -	<b>Data type:</b> Unsigned8	
<b>Can be changed:</b> -	<b>Scaling:</b> -	<b>Dynamic index:</b> -	
<b>Unit group:</b> -	<b>Unit selection:</b> -	<b>Function diagram:</b> -	
<b>Min:</b>	<b>Max:</b>	<b>Factory setting:</b>	
-	-	-	

**Description:** Displays the actual station name for the onboard PROFINET interface on the Control Unit.

---

<b>r8931[0...3]</b>	<b>PN IP address actual / PN IP addr act</b>		
<b>Access level:</b> 3	<b>Calculated:</b> -	<b>Data type:</b> Unsigned8	
<b>Can be changed:</b> -	<b>Scaling:</b> -	<b>Dynamic index:</b> -	
<b>Unit group:</b> -	<b>Unit selection:</b> -	<b>Function diagram:</b> -	
<b>Min:</b>	<b>Max:</b>	<b>Factory setting:</b>	
0	255	-	

**Description:** Displays the actual IP address for the onboard PROFINET interface on the Control Unit.

---

<b>r8932[0...3]</b>	<b>PN Default Gateway actual / PN Def Gateway act</b>		
<b>Access level:</b> 3	<b>Calculated:</b> -	<b>Data type:</b> Unsigned8	
<b>Can be changed:</b> -	<b>Scaling:</b> -	<b>Dynamic index:</b> -	
<b>Unit group:</b> -	<b>Unit selection:</b> -	<b>Function diagram:</b> -	
<b>Min:</b>	<b>Max:</b>	<b>Factory setting:</b>	
0	255	-	

**Description:** Displays the actual default gateway for the onboard PROFINET interface on the Control Unit.

---

<b>r8933[0...3]</b>	<b>PN Subnet Mask actual / PN Subnet Mask act</b>		
<b>Access level:</b> 3	<b>Calculated:</b> -	<b>Data type:</b> Unsigned8	
<b>Can be changed:</b> -	<b>Scaling:</b> -	<b>Dynamic index:</b> -	
<b>Unit group:</b> -	<b>Unit selection:</b> -	<b>Function diagram:</b> -	
<b>Min:</b>	<b>Max:</b>	<b>Factory setting:</b>	
0	255	-	

**Description:** Displays the actual subnet mask for the onboard PROFINET interface on the Control Unit.

---

<b>r8934</b>	<b>PN DHCP Mode actual / PN DHCP Mode act</b>		
<b>Access level:</b> 3	<b>Calculated:</b> -	<b>Data type:</b> Integer16	
<b>Can be changed:</b> -	<b>Scaling:</b> -	<b>Dynamic index:</b> -	
<b>Unit group:</b> -	<b>Unit selection:</b> -	<b>Function diagram:</b> -	
<b>Min:</b>	<b>Max:</b>	<b>Factory setting:</b>	
0	3	-	

**Description:** Displays the actual DHCP mode for the onboard PROFINET interface on the Control Unit.

- Value:**
- 0: DHCP off
  - 2: DHCP on, identification using MAC address
  - 3: DHCP on, identification via name of station

**NOTICE**

When the DHCP mode is active (parameter value not equal to 0), PROFINET communication via this interface is no longer possible!

---

<b>r8935[0...5]</b>	<b>PN MAC address / PN MAC addr</b>		
	<b>Access level:</b> 3	<b>Calculated:</b> -	<b>Data type:</b> Unsigned8
	<b>Can be changed:</b> -	<b>Scaling:</b> -	<b>Dynamic index:</b> -
	<b>Unit group:</b> -	<b>Unit selection:</b> -	<b>Function diagram:</b> -
	<b>Min:</b> 0000 hex	<b>Max:</b> 00FF hex	<b>Factory setting:</b> -
<b>Description:</b>	Displays the MAC address for the onboard PROFINET interface on the Control Unit.		

---

<b>r8939</b>	<b>PN DAP ID / PN DAP ID</b>		
	<b>Access level:</b> 3	<b>Calculated:</b> -	<b>Data type:</b> Unsigned32
	<b>Can be changed:</b> -	<b>Scaling:</b> -	<b>Dynamic index:</b> -
	<b>Unit group:</b> -	<b>Unit selection:</b> -	<b>Function diagram:</b> -
	<b>Min:</b> -	<b>Max:</b> -	<b>Factory setting:</b> -
<b>Description:</b>	Displays the PROFINET Device Access Point ID (DAP ID) for the onboard PROFINET interface. The combination of device ID (r8909) and DAP ID uniquely identifies a PROFINET access point.		

---

**Note**

List of the SINAMICS DAP IDs:

20007 hex: CBE20 V4.5

20008 hex: CBE20 V4.6

20107 hex: CU310-2 PN V4.5

20108 hex: CU310-2 PN V4.6

20307 hex: CU320-2 PN V4.5

20308 hex: CU320-2 PN V4.6

20407 hex: CU230P-2 PN /CU240x-2 PN V4.5

20408 hex: CU230P-2 PN /CU240x-2 PN /CU250S-2 PN /G110M PN V4.6

20507 hex: CU250D-2 PN V4.5

20508 hex: CU250D-2 PN V4.6

<b>p8980</b>	<b>Ethernet/IP profile / Eth/IP profile</b>		
	<b>Access level:</b> 3	<b>Calculated:</b> -	<b>Data type:</b> Integer16
	<b>Can be changed:</b> T	<b>Scaling:</b> -	<b>Dynamic index:</b> -
	<b>Unit group:</b> -	<b>Unit selection:</b> -	<b>Function diagram:</b> 2473
	<b>Min:</b> 0	<b>Max:</b> 1	<b>Factory setting:</b> 0
<b>Description:</b>	Sets the profile for Ethernet/IP.		
<b>Value:</b>	0: SINAMICS 1: ODVA AC/DC		

---

**Note**

Changes only become effective after POWER ON.

The parameter is not influenced by setting the factory setting.

ODVA: Open DeviceNet Vendor Association

<b>p8981</b>	<b>Ethernet/IP ODVA STOP mode / Eth/IP ODVA STOP</b>		
	<b>Access level:</b> 3	<b>Calculated:</b> -	<b>Data type:</b> Integer16
	<b>Can be changed:</b> T	<b>Scaling:</b> -	<b>Dynamic index:</b> -
	<b>Unit group:</b> -	<b>Unit selection:</b> -	<b>Function diagram:</b> 2473
	<b>Min:</b> 0	<b>Max:</b> 1	<b>Factory setting:</b> 0
<b>Description:</b>	Sets the STOP mode for the Ethernet/IP ODVA profile (p8980 = 1).		

## Parameters

### 7.3 Parameter list

**Value:** 0: OFF1  
1: OFF2

**Dependency:** See also: p8980

---

**Note**

Changes only become effective after POWER ON.  
The parameter is not influenced by setting the factory setting.

---

---

**p8982****Ethernet/IP ODVA speed scaling / Eth/IP ODVA n scal**

<b>Access level:</b> 3	<b>Calculated:</b> -	<b>Data type:</b> Integer16
<b>Can be changed:</b> T	<b>Scaling:</b> -	<b>Dynamic index:</b> -
<b>Unit group:</b> -	<b>Unit selection:</b> -	<b>Function diagram:</b> -
<b>Min:</b> 123	<b>Max:</b> 133	<b>Factory setting:</b> 128

**Description:** Sets the scaling for the speed for Ethernet/IP ODVA profile (p8980 = 1).

**Value:**

123:	32
124:	16
125:	8
126:	4
127:	2
128:	1
129:	0.5
130:	0.25
131:	0.125
132:	0.0625
133:	0.03125

**Dependency:** See also: p8980

---

**Note**

Changes only become effective after POWER ON.  
The parameter is not influenced by setting the factory setting.

---

---

**p8983****Ethernet/IP ODVA torque scaling / Eth/IP ODVA M scal**

<b>Access level:</b> 3	<b>Calculated:</b> -	<b>Data type:</b> Integer16
<b>Can be changed:</b> T	<b>Scaling:</b> -	<b>Dynamic index:</b> -
<b>Unit group:</b> -	<b>Unit selection:</b> -	<b>Function diagram:</b> -
<b>Min:</b> 123	<b>Max:</b> 133	<b>Factory setting:</b> 128

**Description:** Sets the scaling for the torque for Ethernet/IP ODVA profile (p8980 = 1).

**Value:**

123:	32
124:	16
125:	8
126:	4
127:	2
128:	1
129:	0.5
130:	0.25
131:	0.125
132:	0.0625
133:	0.03125

**Dependency:** See also: p8980

**Note**

Changes only become effective after POWER ON.  
The parameter is not influenced by setting the factory setting.

<b>p8991</b>	<b>USB memory access / USB mem acc</b>		
	<b>Access level:</b> 3	<b>Calculated:</b> -	<b>Data type:</b> Integer16
	<b>Can be changed:</b> T	<b>Scaling:</b> -	<b>Dynamic index:</b> -
	<b>Unit group:</b> -	<b>Unit selection:</b> -	<b>Function diagram:</b> -
	<b>Min:</b> 1	<b>Max:</b> 2	<b>Factory setting:</b> 1
<b>Description:</b>	Selects the storage medium for access via the USB mass storage.		
<b>Value:</b>	1: Memory card 2: Flash r/w internal		

**Note**

A change only becomes effective after a POWER ON.  
The parameter is not influenced by setting the factory setting.

<b>p9400</b>	<b>Safely remove memory card / Mem_card rem</b>		
	<b>Access level:</b> 2	<b>Calculated:</b> -	<b>Data type:</b> Integer16
	<b>Can be changed:</b> T	<b>Scaling:</b> -	<b>Dynamic index:</b> -
	<b>Unit group:</b> -	<b>Unit selection:</b> -	<b>Function diagram:</b> -
	<b>Min:</b> 0	<b>Max:</b> 100	<b>Factory setting:</b> 0
<b>Description:</b>	Setting and display when memory card is "removed safely". Procedure: Setting p9400 = 2 results in a value of 3 --> The memory card can be removed safely. After removal the value sets itself to 0 automatically. Setting p9400 = 2 results in a value of 100 --> The memory card cannot be removed safely. Removal may destroy the file system on the memory card. It may be necessary to set p9400 = 2 again.		
<b>Value:</b>	0: No memory card inserted 1: Memory card inserted 2: Request "safe removal" of the memory card 3: "Safe removal" possible 100: "Safe removal" not possible due to access		
<b>Dependency:</b>	See also: r9401		

**NOTICE**

Removing the memory card without a request (p9400 = 2) and confirmation (p9400 = 3) may destroy the file system on the memory card. The memory card will then no longer work properly and must be replaced.

**Note**

The status when the memory card is being "removed safely" is shown in r9401.  
For value = 0, 1, 3, 100:  
These values can only be displayed, not set.

7.3 Parameter list

---

<b>r9401.0...3</b>	<b>CO/BO: Safely remove memory card status / Mem_card rem stat</b>		
	<b>Access level:</b> 2	<b>Calculated:</b> -	<b>Data type:</b> Unsigned16
	<b>Can be changed:</b> -	<b>Scaling:</b> -	<b>Dynamic index:</b> -
	<b>Unit group:</b> -	<b>Unit selection:</b> -	<b>Function diagram:</b> -
	<b>Min:</b>	<b>Max:</b>	<b>Factory setting:</b>
	-	-	-

**Description:** Displays the status of the memory card.

<b>Bit field:</b>	<b>Bit</b>	<b>Signal name</b>	<b>1 signal</b>	<b>0 signal</b>	<b>FP</b>
	00	Memory card inserted	Yes	No	-
	01	Memory card activated	Yes	No	-
	02	SIEMENS memory card	Yes	No	-
	03	Memory card as USB data storage medium from the PC used	Yes	No	-

**Dependency:** See also: p9400

**Note**

For bit 01, 00:  
 Bit 1/0 = 0/0: No memory card inserted (corresponds to p9400 = 0).  
 Bit 1/0 = 0/1: "Safe removal" possible (corresponds to p9400 = 3).  
 Bit 1/0 = 1/0: Status not possible.  
 Bit 1/0 = 1/1: Memory card inserted (corresponds to p9400 = 1, 2, 100).  
 For bit 02, 00:  
 Bit 2/0 = 0/0: No memory card inserted.  
 Bit 2/0 = 0/1: Memory card inserted, but not a SIEMENS memory card.  
 Bit 2/0 = 1/0: Status not possible.  
 Bit 2/0 = 1/1: SIEMENS memory card inserted.

---

<b>r9463</b>	<b>Actual macro / Actual macro</b>		
	<b>Access level:</b> 3	<b>Calculated:</b> -	<b>Data type:</b> Unsigned32
	<b>Can be changed:</b> -	<b>Scaling:</b> -	<b>Dynamic index:</b> -
	<b>Unit group:</b> -	<b>Unit selection:</b> -	<b>Function diagram:</b> -
	<b>Min:</b>	<b>Max:</b>	<b>Factory setting:</b>
	0	999999	-

**Description:** Displays the set valid macro.

**Note**

A value of 0 is displayed if a parameter set by a macro is changed.

---

<b>p9484</b>	<b>BICO interconnections search signal source / BICO S_src srch</b>		
	<b>Access level:</b> 3	<b>Calculated:</b> -	<b>Data type:</b> Unsigned32
	<b>Can be changed:</b> T, U	<b>Scaling:</b> -	<b>Dynamic index:</b> -
	<b>Unit group:</b> -	<b>Unit selection:</b> -	<b>Function diagram:</b> -
	<b>Min:</b>	<b>Max:</b>	<b>Factory setting:</b>
	0	4294967295	0

**Description:** Sets the signal source (BO/CO parameter, BICO coded) to search in the signal sinks.  
 The signal source to be searched for is set in p9484 (BICO-coded) and the search result is specified using the number (r9485) and the first index (r9486).

**Dependency:** See also: r9485, r9486

---

<b>r9485</b>	<b>BICO interconnections signal source search count / BICO S_src srchQty</b>		
	<b>Access level:</b> 3	<b>Calculated:</b> -	<b>Data type:</b> Unsigned16
	<b>Can be changed:</b> -	<b>Scaling:</b> -	<b>Dynamic index:</b> -
	<b>Unit group:</b> -	<b>Unit selection:</b> -	<b>Function diagram:</b> -
	<b>Min:</b>	<b>Max:</b>	<b>Factory setting:</b>
	-	-	-
<b>Description:</b>	Displays the number of BICO interconnections to the signal sink being searched for.		
<b>Dependency:</b>	See also: p9484, r9486		

---

**Note**

The signal source to be searched is set in p9484 (BICO-coded).

The search result is contained in r9482 and r9483 and is specified by the count (r9485) and the first index (r9486).

---

<b>r9486</b>	<b>BICO interconnections signal source search first index / BICO S_src srchIdx</b>		
	<b>Access level:</b> 3	<b>Calculated:</b> -	<b>Data type:</b> Unsigned16
	<b>Can be changed:</b> -	<b>Scaling:</b> -	<b>Dynamic index:</b> -
	<b>Unit group:</b> -	<b>Unit selection:</b> -	<b>Function diagram:</b> -
	<b>Min:</b>	<b>Max:</b>	<b>Factory setting:</b>
	-	-	-
<b>Description:</b>	Displays the first index of the signal source being searched for. The signal source to be searched for is set in p9484 (BICO-coded) and the search result is specified using the number (r9485) and the first index (r9486).		
<b>Dependency:</b>	See also: p9484, r9485		

---

**Note**

The signal source to be searched is set in p9484 (BICO-coded).

The search result is contained in r9482 and r9483 and is specified by the count (r9485) and the first index (r9486).

---

<b>r9925[0...99]</b>	<b>Firmware file incorrect / FW file incorr</b>		
	<b>Access level:</b> 3	<b>Calculated:</b> -	<b>Data type:</b> Unsigned8
	<b>Can be changed:</b> -	<b>Scaling:</b> -	<b>Dynamic index:</b> -
	<b>Unit group:</b> -	<b>Unit selection:</b> -	<b>Function diagram:</b> -
	<b>Min:</b>	<b>Max:</b>	<b>Factory setting:</b>
	-	-	-
<b>Description:</b>	Displays the directory and name of the file whose status as shipped from the factory was identified as impermissible.		
<b>Dependency:</b>	See also: r9926 See also: A01016		

---

**Note**

The directory and name of the file is displayed in the ASCII code.

---

<b>r9926</b>	<b>Firmware check status / FW check status</b>		
	<b>Access level:</b> 3	<b>Calculated:</b> -	<b>Data type:</b> Unsigned8
	<b>Can be changed:</b> -	<b>Scaling:</b> -	<b>Dynamic index:</b> -
	<b>Unit group:</b> -	<b>Unit selection:</b> -	<b>Function diagram:</b> -
	<b>Min:</b>	<b>Max:</b>	<b>Factory setting:</b>
	-	-	-
<b>Description:</b>	Displays the status when the firmware is checked when the system is booted. 0: Firmware not yet checked. 1: Check running. 2: Check successfully completed. 3: Check indicates an error.		

7.3 Parameter list

**Dependency:** See also: r9925  
See also: A01016

---

<b>p11000</b>	<b>BI: Free tec_ctrl 0 enable / Ftec0 enab</b>	<b>Access level:</b> 2	<b>Calculated:</b> -	<b>Data type:</b> Unsigned32 / Binary
		<b>Can be changed:</b> T, U	<b>Scaling:</b> -	<b>Dynamic index:</b> -
		<b>Unit group:</b> -	<b>Unit selection:</b> -	<b>Function diagram:</b> 7030
		<b>Min:</b>	<b>Max:</b>	<b>Factory setting:</b>
		-	-	0

**Description:** Sets the signal source to switch in/switch out the free technology controller 0.  
1 signal: The technology controller is switched in.  
0 signal: The technology controller is switched out.

---

<b>p11026</b>	<b>Free tec_ctrl 0 unit selection / Ftec0 unit sel</b>	<b>Access level:</b> 1	<b>Calculated:</b> -	<b>Data type:</b> Integer16
		<b>Can be changed:</b> C2(5)	<b>Scaling:</b> -	<b>Dynamic index:</b> -
		<b>Unit group:</b> -	<b>Unit selection:</b> -	<b>Function diagram:</b> -
		<b>Min:</b>	<b>Max:</b>	<b>Factory setting:</b>
		1	48	1

**Description:** Sets the unit for the parameters of the free technology controller 0.

- Value:**
- 1: %
  - 2: 1 referred no dimensions
  - 3: bar
  - 4: °C
  - 5: Pa
  - 6: ltr/s
  - 7: m³/s
  - 8: ltr/min
  - 9: m³/min
  - 10: ltr/h
  - 11: m³/h
  - 12: kg/s
  - 13: kg/min
  - 14: kg/h
  - 15: t/min
  - 16: t/h
  - 17: N
  - 18: kN
  - 19: Nm
  - 20: psi
  - 21: °F
  - 22: gallon/s
  - 23: inch³/s
  - 24: gallon/min
  - 25: inch³/min
  - 26: gallon/h
  - 27: inch³/h
  - 28: lb/s
  - 29: lb/min



30:	lb/h
31:	lbf
32:	lbf ft
33:	K
34:	rpm
35:	parts/min
36:	m/s
37:	ft <sup>3</sup> /s
38:	ft <sup>3</sup> /min
39:	BTU/min
40:	BTU/h
41:	mbar
42:	inch wg
43:	ft wg
44:	m wg
45:	% r.h.
46:	g/kg
47:	ppm
48:	kg/cm <sup>2</sup>

**Dependency:** Only units of parameters with unit group 9\_2 can be changed over using this parameter.  
See also: p11027

---

#### p11027 Free tec\_ctrl 0 unit reference quantity / Ftec0 unit ref

<b>Access level:</b> 1	<b>Calculated:</b> -	<b>Data type:</b> FloatingPoint32
<b>Can be changed:</b> T	<b>Scaling:</b> -	<b>Dynamic index:</b> -
<b>Unit group:</b> -	<b>Unit selection:</b> -	<b>Function diagram:</b> -
<b>Min:</b> 0.01	<b>Max:</b> 340.28235E36	<b>Factory setting:</b> 1.00

**Description:** Sets the reference quantity for the unit of the parameters of the free technology controller 0.  
When changing over using changeover parameter p11026 to absolute units, all of the parameters involved refer to the reference quantity.

**Dependency:** See also: p11026

---

#### p11028 Free tec\_ctrl 0 sampling time / Ftec0 t\_samp

<b>Access level:</b> 3	<b>Calculated:</b> -	<b>Data type:</b> Integer16
<b>Can be changed:</b> T	<b>Scaling:</b> -	<b>Dynamic index:</b> -
<b>Unit group:</b> -	<b>Unit selection:</b> -	<b>Function diagram:</b> 7030
<b>Min:</b> 0	<b>Max:</b> 4	<b>Factory setting:</b> 2

**Description:** Sets the sampling time for the free technology controller 0.

**Value:**

0:	Reserved
1:	128 ms
2:	256 ms
3:	512 ms
4:	1024 ms

7.3 Parameter list

---

**r11049.0...11**      **CO/BO: Free tec\_ctrl 0 status word / Ftec0 stat\_word**

<b>Access level:</b> 3	<b>Calculated:</b> -	<b>Data type:</b> Unsigned32
<b>Can be changed:</b> -	<b>Scaling:</b> -	<b>Dynamic index:</b> -
<b>Unit group:</b> -	<b>Unit selection:</b> -	<b>Function diagram:</b> 7030
<b>Min:</b>	<b>Max:</b>	<b>Factory setting:</b>
-	-	-

**Description:** Displays the status word of the free technology controller 0.

**Bit field:**

Bit	Signal name	1 signal	0 signal	FP
00	Deactivated	Yes	No	-
01	Limited	Yes	No	-
08	Actual value at the minimum	Yes	No	-
09	Actual value at the maximum	Yes	No	-
10	Output at the minimum	Yes	No	-
11	Output at the maximum	Yes	No	-

---

**p11053**      **CI: Free tec\_ctrl 0 setpoint signal source / Ftec0 setp s\_s**

<b>Access level:</b> 2	<b>Calculated:</b> -	<b>Data type:</b> Unsigned32 / FloatingPoint32
<b>Can be changed:</b> T, U	<b>Scaling:</b> PERCENT	<b>Dynamic index:</b> -
<b>Unit group:</b> -	<b>Unit selection:</b> -	<b>Function diagram:</b> 7030
<b>Min:</b>	<b>Max:</b>	<b>Factory setting:</b>
-	-	0

**Description:** Sets the signal source for the setpoint of the free technology controller 0.

---

**p11057**      **Free tec\_ctrl 0 setpoint ramp-up time / Ftec0 setp t\_r-up**

<b>Access level:</b> 2	<b>Calculated:</b> -	<b>Data type:</b> FloatingPoint32
<b>Can be changed:</b> T, U	<b>Scaling:</b> -	<b>Dynamic index:</b> -
<b>Unit group:</b> -	<b>Unit selection:</b> -	<b>Function diagram:</b> 7030
<b>Min:</b>	<b>Max:</b>	<b>Factory setting:</b>
0.00 [s]	650.00 [s]	1.00 [s]

**Description:** Sets the ramp-up time for the free technology controller 0.

**Dependency:** See also: p11058

---

**Note**  
The ramp-up time is referred to 100 %.

---

**p11058**      **Free tec\_ctrl 0 setpoint ramp-down time / Ftec0 setp t\_r-dn**

<b>Access level:</b> 2	<b>Calculated:</b> -	<b>Data type:</b> FloatingPoint32
<b>Can be changed:</b> T, U	<b>Scaling:</b> -	<b>Dynamic index:</b> -
<b>Unit group:</b> -	<b>Unit selection:</b> -	<b>Function diagram:</b> 7030
<b>Min:</b>	<b>Max:</b>	<b>Factory setting:</b>
0.00 [s]	650.00 [s]	1.00 [s]

**Description:** Sets the ramp-down time for the free technology controller 0.

**Dependency:** See also: p11057

---

**Note**  
The ramp-down time is referred to 100 %.

<b>r11060</b>	<b>CO: Free tec_ctrl 0 setpoint after ramp-function generator / Ftec0 setp aft RFG</b>		
	<b>Access level:</b> 2	<b>Calculated:</b> -	<b>Data type:</b> FloatingPoint32
	<b>Can be changed:</b> -	<b>Scaling:</b> PERCENT	<b>Dynamic index:</b> -
	<b>Unit group:</b> 9_2	<b>Unit selection:</b> p11026	<b>Function diagram:</b> 7030
	<b>Min:</b> - [%]	<b>Max:</b> - [%]	<b>Factory setting:</b> - [%]
<b>Description:</b>	Display and connector output for the setpoint after the ramp-function generator of the free technology controller 0.		

<b>p11063</b>	<b>Free tec_ctrl 0 system deviation inversion / Ftec0 sys_dev inv</b>		
	<b>Access level:</b> 3	<b>Calculated:</b> -	<b>Data type:</b> Integer16
	<b>Can be changed:</b> T	<b>Scaling:</b> -	<b>Dynamic index:</b> -
	<b>Unit group:</b> -	<b>Unit selection:</b> -	<b>Function diagram:</b> 7030
	<b>Min:</b> 0	<b>Max:</b> 1	<b>Factory setting:</b> 0
<b>Description:</b>	Sets the inversion of the system deviation of the free technology controller 0. The setting depends on the type of control loop.		
<b>Value:</b>	0: No inversion 1: Inversion		

**⚠ CAUTION**

If the actual value inversion is incorrectly selected, then the closed-loop control with the technology controller can become unstable and can oscillate!

**Note**

The correct setting can be determined as follows:

- inhibit free technology controller (p11200 = 0).
- increase the motor speed and in so doing, measure the actual value signal (of the free technology controller).
- if the actual value increases with increasing motor speed, then deactivate inversion.
- if the actual value decreases with increasing motor speed, then activate inversion.

If value = 0:

The drive reduces the output speed when the actual value rises (e.g. for heating fans, intake pump, compressor).

If value = 1:

The drive increases the output speed when the actual value increases (e.g. for cooling fans, discharge pumps).

<b>p11064</b>	<b>CI: Free tec_ctrl 0 actual value signal source / Ftec0 act v s_s</b>		
	<b>Access level:</b> 2	<b>Calculated:</b> -	<b>Data type:</b> Unsigned32 / FloatingPoint32
	<b>Can be changed:</b> T, U	<b>Scaling:</b> PERCENT	<b>Dynamic index:</b> -
	<b>Unit group:</b> -	<b>Unit selection:</b> -	<b>Function diagram:</b> 7030
	<b>Min:</b> -	<b>Max:</b> -	<b>Factory setting:</b> 0
<b>Description:</b>	Sets the signal source for the actual value of the free technology controller 0.		

<b>p11065</b>	<b>Free tec_ctrl 0 actual value smoothing time constant / Ftec0 act v T</b>		
	<b>Access level:</b> 2	<b>Calculated:</b> -	<b>Data type:</b> FloatingPoint32
	<b>Can be changed:</b> T, U	<b>Scaling:</b> -	<b>Dynamic index:</b> -
	<b>Unit group:</b> -	<b>Unit selection:</b> -	<b>Function diagram:</b> 7030
	<b>Min:</b> 0.00 [s]	<b>Max:</b> 60.00 [s]	<b>Factory setting:</b> 0.00 [s]
<b>Description:</b>	Sets the smoothing time constant (PT1) for the actual value of the free technology controller 0.		

<b>p11067</b>	<b>Free tec_ctrl 0 actual value upper limit / Ftec0 act v up lim</b>	<b>Access level:</b> 3 <b>Can be changed:</b> T, U <b>Unit group:</b> 9_2 <b>Min:</b> -200.00 [%]	<b>Calculated:</b> - <b>Scaling:</b> PERCENT <b>Unit selection:</b> p11026 <b>Max:</b> 200.00 [%]	<b>Data type:</b> FloatingPoint32 <b>Dynamic index:</b> - <b>Function diagram:</b> 7030 <b>Factory setting:</b> 100.00 [%]
<b>Description:</b>	Sets the upper limit for the actual value signal of the free technology controller 0.			
<b>Dependency:</b>	See also: p11064			
<b>p11068</b>	<b>Free tec_ctrl 0 actual value lower limit / Ftec0 act v lo lim</b>	<b>Access level:</b> 3 <b>Can be changed:</b> T, U <b>Unit group:</b> 9_2 <b>Min:</b> -200.00 [%]	<b>Calculated:</b> - <b>Scaling:</b> PERCENT <b>Unit selection:</b> p11026 <b>Max:</b> 200.00 [%]	<b>Data type:</b> FloatingPoint32 <b>Dynamic index:</b> - <b>Function diagram:</b> 7030 <b>Factory setting:</b> -100.00 [%]
<b>Description:</b>	Sets the lower limit for the actual value signal of the free technology controller 0.			
<b>Dependency:</b>	See also: p11064			
<b>p11071</b>	<b>Free tec_ctrl 0 actual value inversion / Ftec0 act v inv</b>	<b>Access level:</b> 3 <b>Can be changed:</b> T <b>Unit group:</b> - <b>Min:</b> 0	<b>Calculated:</b> - <b>Scaling:</b> - <b>Unit selection:</b> - <b>Max:</b> 1	<b>Data type:</b> Integer16 <b>Dynamic index:</b> - <b>Function diagram:</b> 7030 <b>Factory setting:</b> 0
<b>Description:</b>	Sets the inversion of the actual value signal of the free technology controller 0.			
<b>Value:</b>	0: No inversion 1: Inversion			
<b>r11072</b>	<b>CO: Free tec_ctrl 0 actual value after limiter / Ftec0 act v af lim</b>	<b>Access level:</b> 2 <b>Can be changed:</b> - <b>Unit group:</b> 9_2 <b>Min:</b> - [%]	<b>Calculated:</b> - <b>Scaling:</b> PERCENT <b>Unit selection:</b> p11026 <b>Max:</b> - [%]	<b>Data type:</b> FloatingPoint32 <b>Dynamic index:</b> - <b>Function diagram:</b> 7030 <b>Factory setting:</b> - [%]
<b>Description:</b>	Display and connector output for the actual value after the limiter of the free technology controller 0.			
<b>r11073</b>	<b>CO: Free tec_ctrl 0 system deviation / Ftec0 sys dev</b>	<b>Access level:</b> 2 <b>Can be changed:</b> - <b>Unit group:</b> 9_2 <b>Min:</b> - [%]	<b>Calculated:</b> - <b>Scaling:</b> PERCENT <b>Unit selection:</b> p11026 <b>Max:</b> - [%]	<b>Data type:</b> FloatingPoint32 <b>Dynamic index:</b> - <b>Function diagram:</b> 7030 <b>Factory setting:</b> - [%]
<b>Description:</b>	Display and connector output for the system deviation of the free technology controller 0.			

---

<b>p11074</b>	<b>Free tec_ctrl 0 differentiation time constant / Ftec0 D comp T</b>		
	<b>Access level:</b> 2	<b>Calculated:</b> -	<b>Data type:</b> FloatingPoint32
	<b>Can be changed:</b> T, U	<b>Scaling:</b> -	<b>Dynamic index:</b> -
	<b>Unit group:</b> -	<b>Unit selection:</b> -	<b>Function diagram:</b> 7030
	<b>Min:</b> 0.000 [s]	<b>Max:</b> 60.000 [s]	<b>Factory setting:</b> 0.000 [s]
<b>Description:</b>	Sets the time constant for the differentiation (D component) of the free technology controller 0.		
	<b>Note</b> Value = 0: Differentiation is deactivated.		

---

<b>p11080</b>	<b>Free tec_ctrl 0 proportional gain / Ftec0 Kp</b>		
	<b>Access level:</b> 2	<b>Calculated:</b> -	<b>Data type:</b> FloatingPoint32
	<b>Can be changed:</b> T, U	<b>Scaling:</b> -	<b>Dynamic index:</b> -
	<b>Unit group:</b> -	<b>Unit selection:</b> -	<b>Function diagram:</b> 7030
	<b>Min:</b> 0.000	<b>Max:</b> 1000.000	<b>Factory setting:</b> 1.000
<b>Description:</b>	Sets the proportional gain (P component) of the free technology controller 0.		
	<b>Note</b> Value = 0: The proportional gain is deactivated.		

---

<b>p11085</b>	<b>Free tec_ctrl 0 integral time / Ftec0 Tn</b>		
	<b>Access level:</b> 2	<b>Calculated:</b> -	<b>Data type:</b> FloatingPoint32
	<b>Can be changed:</b> T, U	<b>Scaling:</b> -	<b>Dynamic index:</b> -
	<b>Unit group:</b> -	<b>Unit selection:</b> -	<b>Function diagram:</b> 7030
	<b>Min:</b> 0.000 [s]	<b>Max:</b> 10000.000 [s]	<b>Factory setting:</b> 30.000 [s]
<b>Description:</b>	Sets the integral time (I component, integrating time constant) of the free technology controller 0.		
	<b>Note</b> Value = 0: The integral time is disabled. If the parameter is set to zero during operation, the I component retains its most recent value.		

---

<b>p11091</b>	<b>CO: Free tec_ctrl 0 limit maximum / Ftec0 lim max</b>		
	<b>Access level:</b> 3	<b>Calculated:</b> -	<b>Data type:</b> FloatingPoint32
	<b>Can be changed:</b> T, U	<b>Scaling:</b> PERCENT	<b>Dynamic index:</b> -
	<b>Unit group:</b> -	<b>Unit selection:</b> -	<b>Function diagram:</b> 7030
	<b>Min:</b> -200.00 [%]	<b>Max:</b> 200.00 [%]	<b>Factory setting:</b> 100.00 [%]
<b>Description:</b>	Sets the maximum limit of the free technology controller 0.		
<b>Dependency:</b>	See also: p11092		
	<b>Note</b> The maximum limit must always be greater than the minimum limit (p11091 > p11092).		

---

<b>p11092</b>	<b>CO: Free tec_ctrl 0 limit minimum / Ftec0 lim min</b>		
	<b>Access level:</b> 3	<b>Calculated:</b> -	<b>Data type:</b> FloatingPoint32
	<b>Can be changed:</b> T, U	<b>Scaling:</b> PERCENT	<b>Dynamic index:</b> -
	<b>Unit group:</b> -	<b>Unit selection:</b> -	<b>Function diagram:</b> 7030
	<b>Min:</b> -200.00 [%]	<b>Max:</b> 200.00 [%]	<b>Factory setting:</b> 0.00 [%]

## Parameters

### 7.3 Parameter list

**Description:** Sets the minimum limit of the free technology controller 0.

**Dependency:** See also: p11091

---

**Note**

The maximum limit must always be greater than the minimum limit (p11091 > p11092).

---

---

#### p11093 Free tec\_ctrl 0 limit ramp-up/ramp-down time / Ftec0 lim r-u/r-dn

**Access level:** 3

**Calculated:** -

**Data type:** FloatingPoint32

**Can be changed:** T, U

**Scaling:** -

**Dynamic index:** -

**Unit group:** -

**Unit selection:** -

**Function diagram:** 7030

**Min:**

**Max:**

**Factory setting:**

0.00 [s]

100.00 [s]

1.00 [s]

**Description:** Sets the ramp-up and ramp-down time for the maximum and minimum limit (p11091, p11092) of the free technology controller 0.

**Dependency:** See also: p11091, p11092

---

**Note**

The ramp-up/ramp-down times are referred to 100%.

---

---

#### r11094 CO: Free tec\_ctrl 0 output signal / Ftec0 out\_sig

**Access level:** 2

**Calculated:** -

**Data type:** FloatingPoint32

**Can be changed:** -

**Scaling:** PERCENT

**Dynamic index:** -

**Unit group:** -

**Unit selection:** -

**Function diagram:** 7030

**Min:**

**Max:**

**Factory setting:**

- [%]

- [%]

- [%]

**Description:** Display and connector output for the output signal of the free technology controller 0.

---

---

#### p11097 CI: Free tec\_ctrl 0 limit maximum signal source / Ftec0 lim max s\_s

**Access level:** 3

**Calculated:** -

**Data type:** Unsigned32 /  
FloatingPoint32

**Can be changed:** T, U

**Scaling:** PERCENT

**Dynamic index:** -

**Unit group:** -

**Unit selection:** -

**Function diagram:** 7030

**Min:**

**Max:**

**Factory setting:**

-

-

11091[0]

**Description:** Sets the signal source for the maximum limit of the free technology controller 0.

**Dependency:** See also: p11091

---

---

#### p11098 CI: Free tec\_ctrl 0 limit minimum signal source / Ftec0 lim min s\_s

**Access level:** 3

**Calculated:** -

**Data type:** Unsigned32 /  
FloatingPoint32

**Can be changed:** T, U

**Scaling:** PERCENT

**Dynamic index:** -

**Unit group:** -

**Unit selection:** -

**Function diagram:** 7030

**Min:**

**Max:**

**Factory setting:**

-

-

11092[0]

**Description:** Sets the signal source for the minimum limit of the free technology controller 0.

**Dependency:** See also: p11092

---

<b>p11099</b>	<b>Cl: Free tec_ctrl 0 limit offset signal source / Ftec0 lim offs</b>		
	<b>Access level:</b> 3	<b>Calculated:</b> -	<b>Data type:</b> Unsigned32 / FloatingPoint32
	<b>Can be changed:</b> T, U	<b>Scaling:</b> PERCENT	<b>Dynamic index:</b> -
	<b>Unit group:</b> -	<b>Unit selection:</b> -	<b>Function diagram:</b> 7030
	<b>Min:</b> -	<b>Max:</b> -	<b>Factory setting:</b> 0
<b>Description:</b>	Sets the signal source for the limit offset of the free technology controller 0.		
<b>p11100</b>	<b>Bl: Free tec_ctrl 1 enable / Ftec1 enab</b>		
	<b>Access level:</b> 2	<b>Calculated:</b> -	<b>Data type:</b> Unsigned32 / Binary
	<b>Can be changed:</b> T, U	<b>Scaling:</b> -	<b>Dynamic index:</b> -
	<b>Unit group:</b> -	<b>Unit selection:</b> -	<b>Function diagram:</b> 7030
	<b>Min:</b> -	<b>Max:</b> -	<b>Factory setting:</b> 0
<b>Description:</b>	Sets the signal source to switch in/switch out the free technology controller 1. 1 signal: The technology controller is switched in. 0 signal: The technology controller is switched out.		
<b>p11126</b>	<b>Free tec_ctrl 1 unit selection / Ftec1 unit sel</b>		
	<b>Access level:</b> 1	<b>Calculated:</b> -	<b>Data type:</b> Integer16
	<b>Can be changed:</b> C2(5)	<b>Scaling:</b> -	<b>Dynamic index:</b> -
	<b>Unit group:</b> -	<b>Unit selection:</b> -	<b>Function diagram:</b> 7030
	<b>Min:</b> 1	<b>Max:</b> 48	<b>Factory setting:</b> 1
<b>Description:</b>	Sets the unit for the parameters of the free technology controller 1.		
<b>Value:</b>	1: % 2: 1 referred no dimensions 3: bar 4: °C 5: Pa 6: ltr/s 7: m³/s 8: ltr/min 9: m³/min 10: ltr/h 11: m³/h 12: kg/s 13: kg/min 14: kg/h 15: t/min 16: t/h 17: N 18: kN 19: Nm 20: psi 21: °F 22: gallon/s 23: inch³/s		

7.3 Parameter list

- 24: gallon/min
- 25: inch<sup>3</sup>/min
- 26: gallon/h
- 27: inch<sup>3</sup>/h
- 28: lb/s
- 29: lb/min
- 30: lb/h
- 31: lbf
- 32: lbf ft
- 33: K
- 34: rpm
- 35: parts/min
- 36: m/s
- 37: ft<sup>3</sup>/s
- 38: ft<sup>3</sup>/min
- 39: BTU/min
- 40: BTU/h
- 41: mbar
- 42: inch wg
- 43: ft wg
- 44: m wg
- 45: % r.h.
- 46: g/kg
- 47: ppm
- 48: kg/cm<sup>2</sup>

**Dependency:** Only units of parameters with unit group 9\_3 can be changed over using this parameter.  
See also: p11127

**p11127**      **Free tec\_ctrl 1 unit reference quantity / Ftec1 unit ref**

<b>Access level:</b> 1	<b>Calculated:</b> -	<b>Data type:</b> FloatingPoint32
<b>Can be changed:</b> T	<b>Scaling:</b> -	<b>Dynamic index:</b> -
<b>Unit group:</b> -	<b>Unit selection:</b> -	<b>Function diagram:</b> 7030
<b>Min:</b> 0.01	<b>Max:</b> 340.28235E36	<b>Factory setting:</b> 1.00

**Description:** Sets the reference quantity for the unit of the parameters of the free technology controller 1.  
When changing over using changeover parameter p11126 to absolute units, all of the parameters involved refer to the reference quantity.

**Dependency:** See also: p11126

**p11128**      **Free tec\_ctrl 1 sampling time / Ftec1 t\_samp**

<b>Access level:</b> 3	<b>Calculated:</b> -	<b>Data type:</b> Integer16
<b>Can be changed:</b> T	<b>Scaling:</b> -	<b>Dynamic index:</b> -
<b>Unit group:</b> -	<b>Unit selection:</b> -	<b>Function diagram:</b> 7030
<b>Min:</b> 0	<b>Max:</b> 4	<b>Factory setting:</b> 2

**Description:** Sets the sampling time for the free technology controller 1.

**Value:**

- 0: Reserved
- 1: 128 ms
- 2: 256 ms



3: 512 ms  
4: 1024 ms

<b>r11149.0...11</b>	<b>CO/BO: Free tec_ctrl 1 status word / Ftec1 stat_word</b>		
	<b>Access level:</b> 3	<b>Calculated:</b> -	<b>Data type:</b> Unsigned32
	<b>Can be changed:</b> -	<b>Scaling:</b> -	<b>Dynamic index:</b> -
	<b>Unit group:</b> -	<b>Unit selection:</b> -	<b>Function diagram:</b> 7030
	<b>Min:</b> -	<b>Max:</b> -	<b>Factory setting:</b> -
<b>Description:</b>	Displays the status word of the free technology controller 1.		
<b>Bit field:</b>	<b>Bit</b>	<b>Signal name</b>	<b>1 signal</b> <b>0 signal</b> <b>FP</b>
	00	Deactivated	Yes      No      -
	01	Limited	Yes      No      -
	08	Actual value at the minimum	Yes      No      -
	09	Actual value at the maximum	Yes      No      -
	10	Output at the minimum	Yes      No      -
	11	Output at the maximum	Yes      No      -
<b>p11153</b>	<b>CI: Free tec_ctrl 1 setpoint signal source / Ftec1 setp s_s</b>		
	<b>Access level:</b> 2	<b>Calculated:</b> -	<b>Data type:</b> Unsigned32 / FloatingPoint32
	<b>Can be changed:</b> T, U	<b>Scaling:</b> PERCENT	<b>Dynamic index:</b> -
	<b>Unit group:</b> -	<b>Unit selection:</b> -	<b>Function diagram:</b> 7030
	<b>Min:</b> -	<b>Max:</b> -	<b>Factory setting:</b> 0
<b>Description:</b>	Sets the signal source for the setpoint of the free technology controller 1.		
<b>p11157</b>	<b>Free tec_ctrl 1 setpoint ramp-up time / Ftec1 setp t_r-up</b>		
	<b>Access level:</b> 2	<b>Calculated:</b> -	<b>Data type:</b> FloatingPoint32
	<b>Can be changed:</b> T, U	<b>Scaling:</b> -	<b>Dynamic index:</b> -
	<b>Unit group:</b> -	<b>Unit selection:</b> -	<b>Function diagram:</b> 7030
	<b>Min:</b> 0.00 [s]	<b>Max:</b> 650.00 [s]	<b>Factory setting:</b> 1.00 [s]
<b>Description:</b>	Sets the ramp-up time for the free technology controller 1.		
<b>Dependency:</b>	See also: p11158		
	<b>Note</b>		
	The ramp-up time is referred to 100 %.		
<b>p11158</b>	<b>Free tec_ctrl 1 setpoint ramp-down time / Ftec1 setp t_r-dn</b>		
	<b>Access level:</b> 2	<b>Calculated:</b> -	<b>Data type:</b> FloatingPoint32
	<b>Can be changed:</b> T, U	<b>Scaling:</b> -	<b>Dynamic index:</b> -
	<b>Unit group:</b> -	<b>Unit selection:</b> -	<b>Function diagram:</b> 7030
	<b>Min:</b> 0.00 [s]	<b>Max:</b> 650.00 [s]	<b>Factory setting:</b> 1.00 [s]
<b>Description:</b>	Sets the ramp-down time of the free technology controller 1.		
<b>Dependency:</b>	See also: p11157		
	<b>Note</b>		
	The ramp-down time is referred to 100 %.		

7.3 Parameter list

**r11160**      **CO: Free tec\_ctrl 1 setpoint after ramp-function generator / Ftec1 setp aft RFG**

<b>Access level:</b> 2	<b>Calculated:</b> -	<b>Data type:</b> FloatingPoint32
<b>Can be changed:</b> -	<b>Scaling:</b> PERCENT	<b>Dynamic index:</b> -
<b>Unit group:</b> 9_3	<b>Unit selection:</b> p11126	<b>Function diagram:</b> 7030
<b>Min:</b>	<b>Max:</b>	<b>Factory setting:</b>
- [%]	- [%]	- [%]

**Description:**      Display and connector output for the setpoint after the ramp-function generator of the free technology controller 1.

**p11163**      **Free tec\_ctrl 1 system deviation inversion / Ftec1 sys\_dev inv**

<b>Access level:</b> 3	<b>Calculated:</b> -	<b>Data type:</b> Integer16
<b>Can be changed:</b> T	<b>Scaling:</b> -	<b>Dynamic index:</b> -
<b>Unit group:</b> -	<b>Unit selection:</b> -	<b>Function diagram:</b> 7030
<b>Min:</b>	<b>Max:</b>	<b>Factory setting:</b>
0	1	0

**Description:**      Sets the inversion of the system deviation of the free technology controller 1.  
The setting depends on the type of control loop.

**Value:**            0:      No inversion  
                         1:      Inversion

**⚠ CAUTION**  
If the actual value inversion is incorrectly selected, then the closed-loop control with the technology controller can become unstable and can oscillate!

**Note**  
The correct setting can be determined as follows:

- inhibit free technology controller (p11200 = 0).
- increase the motor speed and in so doing, measure the actual value signal (of the free technology controller).
- if the actual value increases with increasing motor speed, then deactivate inversion.
- if the actual value decreases with increasing motor speed, then activate inversion.

If value = 0:  
The drive reduces the output speed when the actual value rises (e.g. for heating fans, intake pump, compressor).

If value = 1:  
The drive increases the output speed when the actual value increases (e.g. for cooling fans, discharge pumps).

**p11164**      **CI: Free tec\_ctrl 1 actual value signal source / Ftec1 act v s\_s**

<b>Access level:</b> 2	<b>Calculated:</b> -	<b>Data type:</b> Unsigned32 / FloatingPoint32
<b>Can be changed:</b> T, U	<b>Scaling:</b> PERCENT	<b>Dynamic index:</b> -
<b>Unit group:</b> -	<b>Unit selection:</b> -	<b>Function diagram:</b> 7030
<b>Min:</b>	<b>Max:</b>	<b>Factory setting:</b>
-	-	0

**Description:**      Sets the signal source for the actual value of the free technology controller 1.

**p11165**      **Free tec\_ctrl 1 actual value smoothing time constant / Ftec1 act v T**

<b>Access level:</b> 2	<b>Calculated:</b> -	<b>Data type:</b> FloatingPoint32
<b>Can be changed:</b> T, U	<b>Scaling:</b> -	<b>Dynamic index:</b> -
<b>Unit group:</b> -	<b>Unit selection:</b> -	<b>Function diagram:</b> 7030
<b>Min:</b>	<b>Max:</b>	<b>Factory setting:</b>
0.00 [s]	60.00 [s]	0.00 [s]

**Description:**      Sets the smoothing time constant (PT1) for the actual value of the free technology controller 1.

---

<b>p11167</b>	<b>Free tec_ctrl 1 actual value upper limit / Ftec1 act v up lim</b>		
	<b>Access level:</b> 3	<b>Calculated:</b> -	<b>Data type:</b> FloatingPoint32
	<b>Can be changed:</b> T, U	<b>Scaling:</b> PERCENT	<b>Dynamic index:</b> -
	<b>Unit group:</b> 9_3	<b>Unit selection:</b> p11126	<b>Function diagram:</b> 7030
	<b>Min:</b> -200.00 [%]	<b>Max:</b> 200.00 [%]	<b>Factory setting:</b> 100.00 [%]
<b>Description:</b>	Sets the upper limit for the actual value signal of the free technology controller 1.		
<b>Dependency:</b>	See also: p11164		

---

<b>p11168</b>	<b>Free tec_ctrl 1 actual value lower limit / Ftec1 act v lo lim</b>		
	<b>Access level:</b> 3	<b>Calculated:</b> -	<b>Data type:</b> FloatingPoint32
	<b>Can be changed:</b> T, U	<b>Scaling:</b> PERCENT	<b>Dynamic index:</b> -
	<b>Unit group:</b> 9_3	<b>Unit selection:</b> p11126	<b>Function diagram:</b> 7030
	<b>Min:</b> -200.00 [%]	<b>Max:</b> 200.00 [%]	<b>Factory setting:</b> -100.00 [%]
<b>Description:</b>	Sets the lower limit for the actual value signal of the free technology controller 1.		
<b>Dependency:</b>	See also: p11164		

---

<b>p11171</b>	<b>Free tec_ctrl 1 actual value inversion / Ftec1 act v inv</b>		
	<b>Access level:</b> 3	<b>Calculated:</b> -	<b>Data type:</b> Integer16
	<b>Can be changed:</b> T	<b>Scaling:</b> -	<b>Dynamic index:</b> -
	<b>Unit group:</b> -	<b>Unit selection:</b> -	<b>Function diagram:</b> 7030
	<b>Min:</b> 0	<b>Max:</b> 1	<b>Factory setting:</b> 0
<b>Description:</b>	Sets the inversion of the actual value signal of the free technology controller 1.		
<b>Value:</b>	0: No inversion 1: Inversion		

---

<b>r11172</b>	<b>CO: Free tec_ctrl 1 actual value after limiter / Ftec1 act v af lim</b>		
	<b>Access level:</b> 2	<b>Calculated:</b> -	<b>Data type:</b> FloatingPoint32
	<b>Can be changed:</b> -	<b>Scaling:</b> PERCENT	<b>Dynamic index:</b> -
	<b>Unit group:</b> 9_3	<b>Unit selection:</b> p11126	<b>Function diagram:</b> 7030
	<b>Min:</b> - [%]	<b>Max:</b> - [%]	<b>Factory setting:</b> - [%]
<b>Description:</b>	Display and connector output for the actual value after the limiter of the free technology controller 1.		

---

<b>r11173</b>	<b>CO: Free tec_ctrl 1 system deviation / Ftec1 sys dev</b>		
	<b>Access level:</b> 2	<b>Calculated:</b> -	<b>Data type:</b> FloatingPoint32
	<b>Can be changed:</b> -	<b>Scaling:</b> PERCENT	<b>Dynamic index:</b> -
	<b>Unit group:</b> 9_3	<b>Unit selection:</b> p11126	<b>Function diagram:</b> 7030
	<b>Min:</b> - [%]	<b>Max:</b> - [%]	<b>Factory setting:</b> - [%]
<b>Description:</b>	Display and connector output for the system deviation of the free technology controller 1.		

<b>p11174</b>	<b>Free tec_ctrl 1 differentiation time constant / Ftec1 D comp T</b>		
	<b>Access level:</b> 2	<b>Calculated:</b> -	<b>Data type:</b> FloatingPoint32
	<b>Can be changed:</b> T, U	<b>Scaling:</b> -	<b>Dynamic index:</b> -
	<b>Unit group:</b> -	<b>Unit selection:</b> -	<b>Function diagram:</b> 7030
	<b>Min:</b> 0.000 [s]	<b>Max:</b> 60.000 [s]	<b>Factory setting:</b> 0.000 [s]
<b>Description:</b>	Sets the time constant for the differentiation (D component) of the free technology controller 1.		

**Note**

Value = 0: Differentiation is deactivated.

<b>p11180</b>	<b>Free tec_ctrl 1 proportional gain / Ftec1 Kp</b>		
	<b>Access level:</b> 2	<b>Calculated:</b> -	<b>Data type:</b> FloatingPoint32
	<b>Can be changed:</b> T, U	<b>Scaling:</b> -	<b>Dynamic index:</b> -
	<b>Unit group:</b> -	<b>Unit selection:</b> -	<b>Function diagram:</b> 7030
	<b>Min:</b> 0.000	<b>Max:</b> 1000.000	<b>Factory setting:</b> 1.000
<b>Description:</b>	Sets the proportional gain (P component) of the free technology controller 1.		

**Note**

Value = 0: The proportional gain is deactivated.

<b>p11185</b>	<b>Free tec_ctrl 1 integral time / Ftec1 Tn</b>		
	<b>Access level:</b> 2	<b>Calculated:</b> -	<b>Data type:</b> FloatingPoint32
	<b>Can be changed:</b> T, U	<b>Scaling:</b> -	<b>Dynamic index:</b> -
	<b>Unit group:</b> -	<b>Unit selection:</b> -	<b>Function diagram:</b> 7030
	<b>Min:</b> 0.000 [s]	<b>Max:</b> 10000.000 [s]	<b>Factory setting:</b> 30.000 [s]
<b>Description:</b>	Sets the integral time (I component, integrating time constant) of the free technology controller 1.		

**Note**

Value = 0: The integral time is disabled.

If the parameter is set to zero during operation, the I component retains its most recent value.

<b>p11191</b>	<b>CO: Free tec_ctrl 1 limit maximum / Ftec1 lim max</b>		
	<b>Access level:</b> 3	<b>Calculated:</b> -	<b>Data type:</b> FloatingPoint32
	<b>Can be changed:</b> T, U	<b>Scaling:</b> PERCENT	<b>Dynamic index:</b> -
	<b>Unit group:</b> -	<b>Unit selection:</b> -	<b>Function diagram:</b> 7030
	<b>Min:</b> -200.00 [%]	<b>Max:</b> 200.00 [%]	<b>Factory setting:</b> 100.00 [%]
<b>Description:</b>	Sets the maximum limit of the free technology controller 1.		
<b>Dependency:</b>	See also: p11192		

**Note**

The maximum limit must always be greater than the minimum limit (p11191 &gt; p11192).

<b>p11192</b>	<b>CO: Free tec_ctrl 1 limit minimum / Ftec1 lim min</b>		
	<b>Access level:</b> 3	<b>Calculated:</b> -	<b>Data type:</b> FloatingPoint32
	<b>Can be changed:</b> T, U	<b>Scaling:</b> PERCENT	<b>Dynamic index:</b> -
	<b>Unit group:</b> -	<b>Unit selection:</b> -	<b>Function diagram:</b> 7030
	<b>Min:</b> -200.00 [%]	<b>Max:</b> 200.00 [%]	<b>Factory setting:</b> 0.00 [%]

**Description:** Sets the minimum limit of the free technology controller 1.

**Dependency:** See also: p11191

---

**Note**

The maximum limit must always be greater than the minimum limit (p11191 > p11192).

---



---

**p11193 Free tec\_ctrl 1 limit ramp-up/ramp-down time / Ftec1 lim r-u/r-dn**

**Access level:** 3

**Calculated:** -

**Data type:** FloatingPoint32

**Can be changed:** T, U

**Scaling:** -

**Dynamic index:** -

**Unit group:** -

**Unit selection:** -

**Function diagram:** 7030

**Min:**

**Max:**

**Factory setting:**

0.00 [s]

100.00 [s]

1.00 [s]

**Description:** Sets the ramp-up and ramp-down time for the maximum and minimum limit (p11191, p11192) of the free technology controller 1.

**Dependency:** See also: p11191, p11192

---

**Note**

The ramp-up/ramp-down times are referred to 100%.

---



---

**r11194 CO: Free tec\_ctrl 1 output signal / Ftec1 out\_sig**

**Access level:** 2

**Calculated:** -

**Data type:** FloatingPoint32

**Can be changed:** -

**Scaling:** PERCENT

**Dynamic index:** -

**Unit group:** -

**Unit selection:** -

**Function diagram:** 7030

**Min:**

**Max:**

**Factory setting:**

- [%]

- [%]

- [%]

**Description:** Display and connector output for the output signal of the free technology controller 1.

---



---

**p11197 Cl: Free tec\_ctrl 1 limit maximum signal source / Ftec1 lim max s\_s**

**Access level:** 3

**Calculated:** -

**Data type:** Unsigned32 /  
FloatingPoint32

**Can be changed:** T, U

**Scaling:** PERCENT

**Dynamic index:** -

**Unit group:** -

**Unit selection:** -

**Function diagram:** 7030

**Min:**

**Max:**

**Factory setting:**

-

-

11191[0]

**Description:** Sets the signal source for the maximum limit of the free technology controller 1.

**Dependency:** See also: p11191

---



---

**p11198 Cl: Free tec\_ctrl 1 limit minimum signal source / Ftec1 lim min s\_s**

**Access level:** 3

**Calculated:** -

**Data type:** Unsigned32 /  
FloatingPoint32

**Can be changed:** T, U

**Scaling:** PERCENT

**Dynamic index:** -

**Unit group:** -

**Unit selection:** -

**Function diagram:** 7030

**Min:**

**Max:**

**Factory setting:**

-

-

11192[0]

**Description:** Sets the signal source for the minimum limit of the free technology controller 1.

**Dependency:** See also: p11192

---

## 7.3 Parameter list

<b>p11199</b>	<b>CI: Free tec_ctrl 1 limit offset signal source / Ftec1 lim offs</b>		
	<b>Access level:</b> 3 <b>Can be changed:</b> T, U <b>Unit group:</b> - <b>Min:</b> -	<b>Calculated:</b> - <b>Scaling:</b> PERCENT <b>Unit selection:</b> - <b>Max:</b> -	<b>Data type:</b> Unsigned32 / FloatingPoint32 <b>Dynamic index:</b> - <b>Function diagram:</b> 7030 <b>Factory setting:</b> 0
<b>Description:</b>	Sets the signal source for the limit offset of the free technology controller 1.		
<b>p11200</b>	<b>BI: Free tec_ctrl 2 enable / Ftec2 enab</b>		
	<b>Access level:</b> 2 <b>Can be changed:</b> T, U <b>Unit group:</b> - <b>Min:</b> -	<b>Calculated:</b> - <b>Scaling:</b> - <b>Unit selection:</b> - <b>Max:</b> -	<b>Data type:</b> Unsigned32 / Binary <b>Dynamic index:</b> - <b>Function diagram:</b> 7030 <b>Factory setting:</b> 0
<b>Description:</b>	Sets the signal source to switch in/switch out the free technology controller 2. 1 signal: The technology controller is switched in. 0 signal: The technology controller is switched out.		
<b>p11226</b>	<b>Free tec_ctrl 2 unit selection / Ftec2 unit sel</b>		
	<b>Access level:</b> 1 <b>Can be changed:</b> C2(5) <b>Unit group:</b> - <b>Min:</b> 1	<b>Calculated:</b> - <b>Scaling:</b> - <b>Unit selection:</b> - <b>Max:</b> 48	<b>Data type:</b> Integer16 <b>Dynamic index:</b> - <b>Function diagram:</b> 7030 <b>Factory setting:</b> 1
<b>Description:</b>	Sets the unit for the parameters of the free technology controller 2.		
<b>Value:</b>	1: % 2: 1 referred no dimensions 3: bar 4: °C 5: Pa 6: ltr/s 7: m³/s 8: ltr/min 9: m³/min 10: ltr/h 11: m³/h 12: kg/s 13: kg/min 14: kg/h 15: t/min 16: t/h 17: N 18: kN 19: Nm 20: psi 21: °F 22: gallon/s 23: inch³/s		

24:	gallon/min
25:	inch <sup>3</sup> /min
26:	gallon/h
27:	inch <sup>3</sup> /h
28:	lb/s
29:	lb/min
30:	lb/h
31:	lbf
32:	lbf ft
33:	K
34:	rpm
35:	parts/min
36:	m/s
37:	ft <sup>3</sup> /s
38:	ft <sup>3</sup> /min
39:	BTU/min
40:	BTU/h
41:	mbar
42:	inch wg
43:	ft wg
44:	m wg
45:	% r.h.
46:	g/kg
47:	ppm
48:	kg/cm <sup>2</sup>

**Dependency:** Only units of parameters with unit group 9\_4 can be changed over using this parameter.  
See also: p11227

---

### p11227 Free tec\_ctrl 2 unit reference quantity / Ftec2 unit ref

<b>Access level:</b> 1	<b>Calculated:</b> -	<b>Data type:</b> FloatingPoint32
<b>Can be changed:</b> T	<b>Scaling:</b> -	<b>Dynamic index:</b> -
<b>Unit group:</b> -	<b>Unit selection:</b> -	<b>Function diagram:</b> 7030
<b>Min:</b> 0.01	<b>Max:</b> 340.28235E36	<b>Factory setting:</b> 1.00

**Description:** Sets the reference quantity for the unit of the parameters of the free technology controller 2.  
When changing over using changeover parameter p11226 to absolute units, all of the parameters involved refer to the reference quantity.

**Dependency:** See also: p11226

---

### p11228 Free tec\_ctrl 2 sampling time / Ftec2 t\_samp

<b>Access level:</b> 3	<b>Calculated:</b> -	<b>Data type:</b> Integer16
<b>Can be changed:</b> T	<b>Scaling:</b> -	<b>Dynamic index:</b> -
<b>Unit group:</b> -	<b>Unit selection:</b> -	<b>Function diagram:</b> 7030
<b>Min:</b> 0	<b>Max:</b> 4	<b>Factory setting:</b> 2

**Description:** Sets the sampling time for the free technology controller 2.

**Value:**

0:	Reserved
1:	128 ms
2:	256 ms





<b>r11260</b>	<b>CO: Free tec_ctrl 2 setpoint after ramp-function generator / Ftec2 setp aft RFG</b>		
	<b>Access level:</b> 2	<b>Calculated:</b> -	<b>Data type:</b> FloatingPoint32
	<b>Can be changed:</b> -	<b>Scaling:</b> PERCENT	<b>Dynamic index:</b> -
	<b>Unit group:</b> 9_4	<b>Unit selection:</b> p11226	<b>Function diagram:</b> 7030
	<b>Min:</b> - [%]	<b>Max:</b> - [%]	<b>Factory setting:</b> - [%]
<b>Description:</b>	Display and connector output for the setpoint after the ramp-function generator of the free technology controller 2.		

<b>p11263</b>	<b>Free tec_ctrl 2 system deviation inversion / Ftec2 sys_dev inv</b>		
	<b>Access level:</b> 3	<b>Calculated:</b> -	<b>Data type:</b> Integer16
	<b>Can be changed:</b> T	<b>Scaling:</b> -	<b>Dynamic index:</b> -
	<b>Unit group:</b> -	<b>Unit selection:</b> -	<b>Function diagram:</b> 7030
	<b>Min:</b> 0	<b>Max:</b> 1	<b>Factory setting:</b> 0
<b>Description:</b>	Sets the inversion of the system deviation of the free technology controller 2. The setting depends on the type of control loop.		
<b>Value:</b>	0: No inversion 1: Inversion		

**⚠ CAUTION**

If the actual value inversion is incorrectly selected, then the closed-loop control with the technology controller can become unstable and can oscillate!

**Note**

The correct setting can be determined as follows:

- inhibit free technology controller (p11200 = 0).
- increase the motor speed and in so doing, measure the actual value signal (of the free technology controller).
- if the actual value increases with increasing motor speed, then deactivate inversion.
- if the actual value decreases with increasing motor speed, then activate inversion.

If value = 0:

The drive reduces the output speed when the actual value rises (e.g. for heating fans, intake pump, compressor).

If value = 1:

The drive increases the output speed when the actual value increases (e.g. for cooling fans, discharge pumps).

<b>p11264</b>	<b>CI: Free tec_ctrl 2 actual value signal source / Ftec2 act v s_s</b>		
	<b>Access level:</b> 2	<b>Calculated:</b> -	<b>Data type:</b> Unsigned32 / FloatingPoint32
	<b>Can be changed:</b> T, U	<b>Scaling:</b> PERCENT	<b>Dynamic index:</b> -
	<b>Unit group:</b> -	<b>Unit selection:</b> -	<b>Function diagram:</b> 7030
	<b>Min:</b> -	<b>Max:</b> -	<b>Factory setting:</b> 0
<b>Description:</b>	Sets the signal source for the actual value of the free technology controller 2.		

<b>p11265</b>	<b>Free tec_ctrl 2 actual value smoothing time constant / Ftec2 act v T</b>		
	<b>Access level:</b> 2	<b>Calculated:</b> -	<b>Data type:</b> FloatingPoint32
	<b>Can be changed:</b> T, U	<b>Scaling:</b> -	<b>Dynamic index:</b> -
	<b>Unit group:</b> -	<b>Unit selection:</b> -	<b>Function diagram:</b> 7030
	<b>Min:</b> 0.00 [s]	<b>Max:</b> 60.00 [s]	<b>Factory setting:</b> 0.00 [s]
<b>Description:</b>	Sets the smoothing time constant (PT1) for the actual value of the free technology controller 2.		

<b>p11267</b>	<b>Free tec_ctrl 2 actual value upper limit / Ftec2 act v up lim</b>	<b>Access level:</b> 3 <b>Can be changed:</b> T, U <b>Unit group:</b> 9_4 <b>Min:</b> -200.00 [%]	<b>Calculated:</b> - <b>Scaling:</b> PERCENT <b>Unit selection:</b> p11226 <b>Max:</b> 200.00 [%]	<b>Data type:</b> FloatingPoint32 <b>Dynamic index:</b> - <b>Function diagram:</b> 7030 <b>Factory setting:</b> 100.00 [%]
<b>Description:</b>	Sets the upper limit for the actual value signal of the free technology controller 2.			
<b>Dependency:</b>	See also: p11264			
<b>p11268</b>	<b>Free tec_ctrl 2 actual value lower limit / Ftec2 act v lo lim</b>	<b>Access level:</b> 3 <b>Can be changed:</b> T, U <b>Unit group:</b> 9_4 <b>Min:</b> -200.00 [%]	<b>Calculated:</b> - <b>Scaling:</b> PERCENT <b>Unit selection:</b> p11226 <b>Max:</b> 200.00 [%]	<b>Data type:</b> FloatingPoint32 <b>Dynamic index:</b> - <b>Function diagram:</b> 7030 <b>Factory setting:</b> -100.00 [%]
<b>Description:</b>	Sets the lower limit for the actual value signal of the free technology controller 2.			
<b>Dependency:</b>	See also: p11264			
<b>p11271</b>	<b>Free tec_ctrl 2 actual value inversion / Ftec2 act v inv</b>	<b>Access level:</b> 3 <b>Can be changed:</b> T <b>Unit group:</b> - <b>Min:</b> 0	<b>Calculated:</b> - <b>Scaling:</b> - <b>Unit selection:</b> - <b>Max:</b> 1	<b>Data type:</b> Integer16 <b>Dynamic index:</b> - <b>Function diagram:</b> 7030 <b>Factory setting:</b> 0
<b>Description:</b>	Sets the inversion of the actual value signal of the free technology controller 2.			
<b>Value:</b>	0: No inversion 1: Inversion			
<b>r11272</b>	<b>CO: Free tec_ctrl 2 actual value after limiter / Ftec2 act v af lim</b>	<b>Access level:</b> 2 <b>Can be changed:</b> - <b>Unit group:</b> 9_4 <b>Min:</b> - [%]	<b>Calculated:</b> - <b>Scaling:</b> PERCENT <b>Unit selection:</b> p11226 <b>Max:</b> - [%]	<b>Data type:</b> FloatingPoint32 <b>Dynamic index:</b> - <b>Function diagram:</b> 7030 <b>Factory setting:</b> - [%]
<b>Description:</b>	Display and connector output for the actual value after the limiter of the free technology controller 2.			
<b>r11273</b>	<b>CO: Free tec_ctrl 2 system deviation / Ftec2 sys dev</b>	<b>Access level:</b> 2 <b>Can be changed:</b> - <b>Unit group:</b> 9_4 <b>Min:</b> - [%]	<b>Calculated:</b> - <b>Scaling:</b> PERCENT <b>Unit selection:</b> p11226 <b>Max:</b> - [%]	<b>Data type:</b> FloatingPoint32 <b>Dynamic index:</b> - <b>Function diagram:</b> 7030 <b>Factory setting:</b> - [%]
<b>Description:</b>	Display and connector output for the system deviation of the free technology controller 2.			

---

<b>p11274</b>	<b>Free tec_ctrl 2 differentiation time constant / Ftec2 D comp T</b>		
	<b>Access level:</b> 2	<b>Calculated:</b> -	<b>Data type:</b> FloatingPoint32
	<b>Can be changed:</b> T, U	<b>Scaling:</b> -	<b>Dynamic index:</b> -
	<b>Unit group:</b> -	<b>Unit selection:</b> -	<b>Function diagram:</b> 7030
	<b>Min:</b> 0.000 [s]	<b>Max:</b> 60.000 [s]	<b>Factory setting:</b> 0.000 [s]

**Description:** Sets the time constant for the differentiation (D component) of the free technology controller 2.

**Note**

Value = 0: Differentiation is deactivated.

---



---

<b>p11280</b>	<b>Free tec_ctrl 2 proportional gain / Ftec2 Kp</b>		
	<b>Access level:</b> 2	<b>Calculated:</b> -	<b>Data type:</b> FloatingPoint32
	<b>Can be changed:</b> T, U	<b>Scaling:</b> -	<b>Dynamic index:</b> -
	<b>Unit group:</b> -	<b>Unit selection:</b> -	<b>Function diagram:</b> 7030
	<b>Min:</b> 0.000	<b>Max:</b> 1000.000	<b>Factory setting:</b> 1.000

**Description:** Sets the proportional gain (P component) of the free technology controller 2.

**Note**

Value = 0: The proportional gain is deactivated.

---



---

<b>p11285</b>	<b>Free tec_ctrl 2 integral time / Ftec2 Tn</b>		
	<b>Access level:</b> 2	<b>Calculated:</b> -	<b>Data type:</b> FloatingPoint32
	<b>Can be changed:</b> T, U	<b>Scaling:</b> -	<b>Dynamic index:</b> -
	<b>Unit group:</b> -	<b>Unit selection:</b> -	<b>Function diagram:</b> 7030
	<b>Min:</b> 0.000 [s]	<b>Max:</b> 10000.000 [s]	<b>Factory setting:</b> 30.000 [s]

**Description:** Sets the integral time (I component, integrating time constant) of the free technology controller 2.

**Note**

Value = 0: The integral time is disabled.

If the parameter is set to zero during operation, the I component retains its most recent value.

---



---

<b>p11291</b>	<b>CO: Free tec_ctrl 2 limit maximum / Ftec2 lim max</b>		
	<b>Access level:</b> 3	<b>Calculated:</b> -	<b>Data type:</b> FloatingPoint32
	<b>Can be changed:</b> T, U	<b>Scaling:</b> PERCENT	<b>Dynamic index:</b> -
	<b>Unit group:</b> -	<b>Unit selection:</b> -	<b>Function diagram:</b> 7030
	<b>Min:</b> -200.00 [%]	<b>Max:</b> 200.00 [%]	<b>Factory setting:</b> 100.00 [%]

**Description:** Sets the maximum limit of the free technology controller 2.

**Dependency:** See also: p11292

**Note**

The maximum limit must always be greater than the minimum limit (p11291 > p11292).

---



---

<b>p11292</b>	<b>CO: Free tec_ctrl 2 limit minimum / Ftec2 lim min</b>		
	<b>Access level:</b> 3	<b>Calculated:</b> -	<b>Data type:</b> FloatingPoint32
	<b>Can be changed:</b> T, U	<b>Scaling:</b> PERCENT	<b>Dynamic index:</b> -
	<b>Unit group:</b> -	<b>Unit selection:</b> -	<b>Function diagram:</b> 7030
	<b>Min:</b> -200.00 [%]	<b>Max:</b> 200.00 [%]	<b>Factory setting:</b> 0.00 [%]

## Parameters

### 7.3 Parameter list

**Description:** Sets the minimum limit of the free technology controller 2.

**Dependency:** See also: p11291

---

**Note**

The maximum limit must always be greater than the minimum limit (p11291 > p11292).

---

---

#### p11293 Free tec\_ctrl 2 limit ramp-up/ramp-down time / Ftec2 lim r-u/r-dn

**Access level:** 3

**Calculated:** -

**Data type:** FloatingPoint32

**Can be changed:** T, U

**Scaling:** -

**Dynamic index:** -

**Unit group:** -

**Unit selection:** -

**Function diagram:** 7030

**Min:**

**Max:**

**Factory setting:**

0.00 [s]

100.00 [s]

1.00 [s]

**Description:** Sets the ramp-up and ramp-down time for the maximum and minimum limit (p11291, p11292) of the free technology controller 2.

**Dependency:** See also: p11291, p11292

---

**Note**

The ramp-up/ramp-down times are referred to 100%.

---

---

#### r11294 CO: Free tec\_ctrl 2 output signal / Ftec2 out\_sig

**Access level:** 2

**Calculated:** -

**Data type:** FloatingPoint32

**Can be changed:** -

**Scaling:** PERCENT

**Dynamic index:** -

**Unit group:** -

**Unit selection:** -

**Function diagram:** 7030

**Min:**

**Max:**

**Factory setting:**

- [%]

- [%]

- [%]

**Description:** Display and connector output for the output signal of the free technology controller 2.

---

---

#### p11297 CI: Free tec\_ctrl 2 limit maximum signal source / Ftec2 lim max s\_s

**Access level:** 3

**Calculated:** -

**Data type:** Unsigned32 /  
FloatingPoint32

**Can be changed:** T, U

**Scaling:** PERCENT

**Dynamic index:** -

**Unit group:** -

**Unit selection:** -

**Function diagram:** 7030

**Min:**

**Max:**

**Factory setting:**

-

-

11291[0]

**Description:** Sets the signal source for the maximum limit of the free technology controller 2.

**Dependency:** See also: p11291

---

---

#### p11298 CI: Free tec\_ctrl 2 limit minimum signal source / Ftec2 lim min s\_s

**Access level:** 3

**Calculated:** -

**Data type:** Unsigned32 /  
FloatingPoint32

**Can be changed:** T, U

**Scaling:** PERCENT

**Dynamic index:** -

**Unit group:** -

**Unit selection:** -

**Function diagram:** 7030

**Min:**

**Max:**

**Factory setting:**

-

-

11292[0]

**Description:** Sets the signal source for the minimum limit of the free technology controller 2.

**Dependency:** See also: p11292

---

<b>p11299</b>	<b>Cl: Free tec_ctrl 2 limit offset signal source / Ftec2 lim offs</b>		
	<b>Access level:</b> 3	<b>Calculated:</b> -	<b>Data type:</b> Unsigned32 / FloatingPoint32
	<b>Can be changed:</b> T, U	<b>Scaling:</b> PERCENT	<b>Dynamic index:</b> -
	<b>Unit group:</b> -	<b>Unit selection:</b> -	<b>Function diagram:</b> 7030
	<b>Min:</b> -	<b>Max:</b> -	<b>Factory setting:</b> 0
<b>Description:</b>	Sets the signal source for the limit offset of the free technology controller 2.		
<b>r29018[0...1]</b>	<b>OA version / OA ver</b>		
	<b>Access level:</b> 3	<b>Calculated:</b> -	<b>Data type:</b> Unsigned16
	<b>Can be changed:</b> -	<b>Scaling:</b> -	<b>Dynamic index:</b> -
	<b>Unit group:</b> -	<b>Unit selection:</b> -	<b>Function diagram:</b> -
	<b>Min:</b> -	<b>Max:</b> -	<b>Factory setting:</b> -
<b>Description:</b>	Displays the OA version.		
<b>Index:</b>	[0] = Firmware version [1] = Build increment number		
<b>p29520</b>	<b>Multi-pump control enable / Mpc enab</b>		
	<b>Access level:</b> 3	<b>Calculated:</b> -	<b>Data type:</b> Integer16
	<b>Can be changed:</b> T	<b>Scaling:</b> -	<b>Dynamic index:</b> -
	<b>Unit group:</b> -	<b>Unit selection:</b> -	<b>Function diagram:</b> -
	<b>Min:</b> 0	<b>Max:</b> 1	<b>Factory setting:</b> 0
<b>Description:</b>	Enables the multi-pump control function. 0: Multi-pump control inhibited 1: Multi-pump control enabled		
<b>Value:</b>	0:       disable 1:       enable		
<b>Dependency:</b>	The "Multi-pump control" function is only available for induction motors. The "Multi-pump control" function is not supported on G120X inverter variants of power rating 30kW or above.		
	<b>Note</b> when P29520=0, P29521 cant set to a !0 value. when P29520 value change from 1 to 0, P29521 value will change to 0 automatically		
<b>p29521</b>	<b>Multi-pump control motor configuration / Mpc mtr num config</b>		
	<b>Access level:</b> 3	<b>Calculated:</b> -	<b>Data type:</b> Integer16
	<b>Can be changed:</b> T	<b>Scaling:</b> -	<b>Dynamic index:</b> -
	<b>Unit group:</b> -	<b>Unit selection:</b> -	<b>Function diagram:</b> -
	<b>Min:</b> 0	<b>Max:</b> 4	<b>Factory setting:</b> 0
<b>Description:</b>	Selects the number of motors that will be used as multi-pump control.		
<b>Value:</b>	0:       NONE 1:       M1=1X 2:       M1=1X,M2=1X 3:       M1=1X,M2=1X,M3=1X 4:       M1=1X,M2=1X,M3=1X,M4=1X		

## 7.3 Parameter list

**Note**

1X means motor power that configured in P307.  
Currently multi-pump control only support that all motors should have the same power.

<b>p29522</b>	<b>Multi-pump control motor selection mode / Mpc mtr sel mode</b>	<b>Access level:</b> 3	<b>Calculated:</b> -	<b>Data type:</b> Integer16
		<b>Can be changed:</b> T	<b>Scaling:</b> -	<b>Dynamic index:</b> -
		<b>Unit group:</b> -	<b>Unit selection:</b> -	<b>Function diagram:</b> -
		<b>Min:</b> 0	<b>Max:</b> 1	<b>Factory setting:</b> 0
<b>Description:</b>	Parameter for selecting the control mode for switching-in and switching-out motors			
<b>Value:</b>	0: Fixed sequence 1: Absolute operating hours			

**Note**

For p29522=0:  
Motor selection for switching-in/switching-out follows a fixed sequence and is dependent on the multi-pump control configuration (p29521).  
For p29522=1:  
Motor selection for switching-in/switching-out is derived from the operating hours counter p29530. When switching-in, the motor with the least operating hours is connected. When switching-out, the motor with the most operating hours is disconnected.

<b>p29523</b>	<b>Multi-pump control switch-in threshold / Mpc sw_in thr</b>	<b>Access level:</b> 3	<b>Calculated:</b> -	<b>Data type:</b> FloatingPoint32
		<b>Can be changed:</b> T, U	<b>Scaling:</b> PERCENT	<b>Dynamic index:</b> -
		<b>Unit group:</b> 9_1	<b>Unit selection:</b> p0595	<b>Function diagram:</b> -
		<b>Min:</b> 0.0 [%]	<b>Max:</b> 200.0 [%]	<b>Factory setting:</b> 20.0 [%]
<b>Description:</b>	Threshold value for the delayed switching-in or switching-out of motors. Motor switching-in is activated if the maximum speed is reached and the wait time in p29524 has expired.			
<b>Dependency:</b>	refer to P29524			

<b>p29524</b>	<b>Multi-pump control switch-in delay / Mpc_ctrl t_in_del</b>	<b>Access level:</b> 3	<b>Calculated:</b> -	<b>Data type:</b> Unsigned16
		<b>Can be changed:</b> T, U	<b>Scaling:</b> -	<b>Dynamic index:</b> -
		<b>Unit group:</b> -	<b>Unit selection:</b> -	<b>Function diagram:</b> -
		<b>Min:</b> 0 [s]	<b>Max:</b> 650 [s]	<b>Factory setting:</b> 30 [s]
<b>Description:</b>	Additional delay time for staging motors after the system deviation of the technology controller has exceeded the threshold value p29523 and the motor has reached the maximum speed.			
<b>Dependency:</b>	refer to P29523			

**Note**

If the deviation at the technology controller input exceeds the overcontrol threshold p29526, the delay time is bypassed.

<b>p29525</b>	<b>Multi-pump control switch-out delay / Mpc sw_out del</b>	<b>Access level:</b> 3	<b>Calculated:</b> -	<b>Data type:</b> Unsigned16
		<b>Can be changed:</b> T, U	<b>Scaling:</b> -	<b>Dynamic index:</b> -
		<b>Unit group:</b> -	<b>Unit selection:</b> -	<b>Function diagram:</b> -
		<b>Min:</b> 0 [s]	<b>Max:</b> 650 [s]	<b>Factory setting:</b> 30 [s]

**Description:** Additional delay time for switch-out motor after the system deviation of the technology controller has exceeded the threshold p29523 and the motor has reached the speed threshold p1080+P29528.

**Dependency:** Refer to P29523,P29526

**Note**

If the deviation at the technology controller input exceeds the overcontrol threshold p29526, the delay time is bypassed. If the hibernation mode is active, ensure that p2391 is longer than p29525 to avoid false operation of hibernation.

**p29526 Multi-pump control overcontrol threshold / Mpc overctrl thr**

**Access level:** 3

**Calculated:** -

**Data type:** FloatingPoint32

**Can be changed:** T, U

**Scaling:** PERCENT

**Dynamic index:** -

**Unit group:** 9\_1

**Unit selection:** p0595

**Function diagram:** -

**Min:**

**Max:**

**Factory setting:**

0.0 [%]

200.0 [%]

25.0 [%]

**Description:** Sets the threshold value for instantaneous switching-in or switching-out motors.

**Note**

If the PID error rises above the multi-pump control overcontrol threshold p29526, the inverter skips the switch-in delay time and performs the switch-in operation immediately.

If the PID error drops below the multi-pump control overcontrol threshold -p29526, the inverter skips the switch-out delay and performs the switch-out operation immediately.

**p29527 Multi-pump control interlocking time / Mpc t\_interl**

**Access level:** 3

**Calculated:** -

**Data type:** Unsigned16

**Can be changed:** T

**Scaling:** -

**Dynamic index:** -

**Unit group:** -

**Unit selection:** -

**Function diagram:** -

**Min:**

**Max:**

**Factory setting:**

0 [s]

650 [s]

0 [s]

**Description:** Interlocking time during which, following the connection or disconnection of a motor, no further motors are connected or disconnected using the multi-control control. This avoids duplicate switching operations.

**p29528 Multi-pump control switch-out speed offset / Mpc sw\_out offset**

**Access level:** 3

**Calculated:** -

**Data type:** FloatingPoint32

**Can be changed:** T, U

**Scaling:** -

**Dynamic index:** -

**Unit group:** 3\_1

**Unit selection:** p0505

**Function diagram:** -

**Min:**

**Max:**

**Factory setting:**

0.0 [rpm]

21000.0 [rpm]

100.0 [rpm]

**Description:** Sets the speed offset which pluses p1080 as the speed threshold.

If the system deviation of the technology controller has exceeded the threshold p29523 for p29525s (or exceeded the threshold p29526) and the motor has reached the speed threshold p1080+p29528, a motor will be switched out.

**r29529.0...7 CO/BO: Multi-pump control status word / Mpc ZSW**

**Access level:** 3

**Calculated:** -

**Data type:** Unsigned32

**Can be changed:** -

**Scaling:** -

**Dynamic index:** -

**Unit group:** -

**Unit selection:** -

**Function diagram:** -

**Min:**

**Max:**

**Factory setting:**

-

-

-

**Description:** Displays the status word of the multi-pump control

Bit field:	Bit	Signal name	1 signal	0 signal	FP
	00	Start motor 1	Yes	No	-
	01	Start motor 2	Yes	No	-
	02	Start motor 3	Yes	No	-

7.3 Parameter list

03	Start motor 4	Yes	No	-
04	Switch-in/switch-out active	Yes	No	-
05	All motors active	Yes	No	-
06	Cycling not possible	Yes	No	-
07	Alarm active	Yes	No	-

**p29530[0...3] Multi-pump control absolute operating hours / Mpc op\_hrs**

<b>Access level:</b> 3	<b>Calculated:</b> -	<b>Data type:</b> FloatingPoint32
<b>Can be changed:</b> T, U	<b>Scaling:</b> -	<b>Dynamic index:</b> -
<b>Unit group:</b> -	<b>Unit selection:</b> -	<b>Function diagram:</b> -
<b>Min:</b> 0.00 [h]	<b>Max:</b> 340.28235E36 [h]	<b>Factory setting:</b> 0.00 [h]

**Description:** Displays the total operating hours for motors.  
The display can only be reset to zero.

**Index:**  
[0] = motor 1 operating hours  
[1] = motor 2 operating hours  
[2] = motor 3 operating hours  
[3] = motor 4 operating hours

---

**Note**  
Absolute operating hours means the total operating hours since the motor's initial operation.

**p29531 Multi-pump control maximum time for continuous operation / Mpc t\_max**

<b>Access level:</b> 3	<b>Calculated:</b> -	<b>Data type:</b> FloatingPoint32
<b>Can be changed:</b> T, U	<b>Scaling:</b> -	<b>Dynamic index:</b> -
<b>Unit group:</b> -	<b>Unit selection:</b> -	<b>Function diagram:</b> -
<b>Min:</b> 0.01 [h]	<b>Max:</b> 100000.00 [h]	<b>Factory setting:</b> 24.00 [h]

**Description:** Time limit for the continuous operation of motors.  
Continuous operation is measured starting from when a motor is ON and It ends when a motor is OFF.

**p29533 Multi-pump control switch-off sequence / Mpc sw\_off seq**

<b>Access level:</b> 3	<b>Calculated:</b> -	<b>Data type:</b> Integer16
<b>Can be changed:</b> T	<b>Scaling:</b> -	<b>Dynamic index:</b> -
<b>Unit group:</b> -	<b>Unit selection:</b> -	<b>Function diagram:</b> -
<b>Min:</b> 0	<b>Max:</b> 1	<b>Factory setting:</b> 0

**Description:** Selection of the response used to stop the motors when the OFF command is sent.  
For p29533 = 1:  
when OFF1:  
In this mode the motors connecting with the mains stop one at a time separated by one ramp down delay in the reverse order in which they were switched on. The inverter controlled motor stops with a normal ramp down (OFF1) which commences when the first motor connecting with the mains is switched off.  
The time set in p29537 is applied as a delay time between the disconnection of each line motor.  
Then speed-regulated motor is ramp down following OFF1 behavior.  
In the case of OFF2 and OFF3, the motors connecting to the line are switched off immediately with the OFF command(same behavior as with p29533=0).Then the inverter controlled motor is ramp down following OFF2 or OFF3 behavior.

**Value:**  
0: Halt normal  
1: Halt sequential



---

<b>p29537</b>	<b>Multi-pump control disconnection lockout time / Mpc t_disc_lockout</b>		
	<b>Access level:</b> 3	<b>Calculated:</b> -	<b>Data type:</b> FloatingPoint32
	<b>Can be changed:</b> T	<b>Scaling:</b> -	<b>Dynamic index:</b> -
	<b>Unit group:</b> -	<b>Unit selection:</b> -	<b>Function diagram:</b> -
	<b>Min:</b> 0.000 [s]	<b>Max:</b> 999.000 [s]	<b>Factory setting:</b> 0.000 [s]
<b>Description:</b>	Multi-pump control-holding time switch-out: The time set in p29537 is applied as a delay time between the disconnection of each motor.		

---

<b>r29538</b>	<b>Multi-pump control variable-speed motor / Mpc driven mtr</b>		
	<b>Access level:</b> 3	<b>Calculated:</b> -	<b>Data type:</b> Integer16
	<b>Can be changed:</b> -	<b>Scaling:</b> -	<b>Dynamic index:</b> -
	<b>Unit group:</b> -	<b>Unit selection:</b> -	<b>Function diagram:</b> -
	<b>Min:</b> -	<b>Max:</b> -	<b>Factory setting:</b> -
<b>Description:</b>	Displays the No. of the motor which is driven by drive. Valid Value : 1 - 4		

---

<b>p29539</b>	<b>Multi-pump control pump switchover enable / Mpc sw-over enab</b>		
	<b>Access level:</b> 3	<b>Calculated:</b> -	<b>Data type:</b> Integer16
	<b>Can be changed:</b> T	<b>Scaling:</b> -	<b>Dynamic index:</b> -
	<b>Unit group:</b> -	<b>Unit selection:</b> -	<b>Function diagram:</b> -
	<b>Min:</b> 0	<b>Max:</b> 1	<b>Factory setting:</b> 0
<b>Description:</b>	Enables the multi-pump control pump switchover function. 0: Pump switchover function inhibited 1: Pump switchover function enabled		
<b>Value:</b>	0:           DISABLE_CYCLING 1:           ENABLE_CYCLING		

---

**Note**

With pump switchover enabled, the inverter monitors the operation status of all running pumps. If the continuous operating hours of the pump in inverter operation exceed the threshold, the inverter switches off the pump and then switches in an idle pump to keep constant output power. If the continuous operating hours of a pump in mains operation exceed the threshold, the inverter switches off the pump, switches the inverter-controlled pump to mains operation, and switches in an idle pump to run in inverter operation to keep constant output power.

---

<b>p29540</b>	<b>Multi-pump control service mode enable / Mpc SerMode enab</b>		
	<b>Access level:</b> 3	<b>Calculated:</b> -	<b>Data type:</b> Integer16
	<b>Can be changed:</b> T	<b>Scaling:</b> -	<b>Dynamic index:</b> -
	<b>Unit group:</b> -	<b>Unit selection:</b> -	<b>Function diagram:</b> -
	<b>Min:</b> 0	<b>Max:</b> 1	<b>Factory setting:</b> 0
<b>Description:</b>	Enables the multi-pump control service mode. 0: Service mode inhibited 1: Service mode enabled		
<b>Value:</b>	0:           disable 1:           enable		

**Note**

When a pump is in service mode, the inverter locks the corresponding relay. Then you can perform troubleshooting of this pump without interrupting the operation of other pumps.

<b>p29542.0...3</b>	<b>CO/BO: Multi-pump control service mode interlock manually / Mpc ser_interl</b>		
	<b>Access level:</b> 3	<b>Calculated:</b> -	<b>Data type:</b> Unsigned32
	<b>Can be changed:</b> T, U	<b>Scaling:</b> -	<b>Dynamic index:</b> -
	<b>Unit group:</b> -	<b>Unit selection:</b> -	<b>Function diagram:</b> -
	<b>Min:</b> -	<b>Max:</b> -	<b>Factory setting:</b> 0000 bin

**Description:** Sets the service mode manually.  
When a motor fault is activated or a motor is not to run, user can set the corresponding bit to 1 to lock it.

<b>Bit field:</b>	<b>Bit</b>	<b>Signal name</b>	<b>1 signal</b>	<b>0 signal</b>	<b>FP</b>
	00	motor 1 locked	Yes	No	-
	01	motor 2 locked	Yes	No	-
	02	motor 3 locked	Yes	No	-
	03	motor 4 locked	Yes	No	-

<b>p29543[0...3]</b>	<b>BI: Multi-pump control motor under repair / Mpc mtr_und_ser</b>		
	<b>Access level:</b> 3	<b>Calculated:</b> -	<b>Data type:</b> Unsigned32 / Binary
	<b>Can be changed:</b> T, U	<b>Scaling:</b> -	<b>Dynamic index:</b> -
	<b>Unit group:</b> -	<b>Unit selection:</b> -	<b>Function diagram:</b> -
	<b>Min:</b> -	<b>Max:</b> -	<b>Factory setting:</b> [0] 29542.0 [1] 29542.1 [2] 29542.2 [3] 29542.3

**Description:** Sets the signal source(digital input or p29542) for service mode.  
The signal indicates the motor/motors which is/are under repair or locked manually.

**Index:** [0] = motor 1 under repair  
[1] = motor 2 under repair  
[2] = motor 3 under repair  
[3] = motor 4 under repair

<b>r29544</b>	<b>Multi-pump control index of motors under repair / Mpc mtr und repair</b>		
	<b>Access level:</b> 3	<b>Calculated:</b> -	<b>Data type:</b> Unsigned32
	<b>Can be changed:</b> -	<b>Scaling:</b> -	<b>Dynamic index:</b> -
	<b>Unit group:</b> -	<b>Unit selection:</b> -	<b>Function diagram:</b> -
	<b>Min:</b> -	<b>Max:</b> -	<b>Factory setting:</b> -

**Description:** Displays the motors which are interlocked/under repair.  
Value:  
r29544.0 = 1: Motor 1 is interlocked / under repair  
r29544.1 = 1: Motor 2 is interlocked / under repair  
r29544.2 = 1: Motor 3 is interlocked / under repair  
r29544.3 = 1: Motor 4 is interlocked / under repair

<b>r29545</b>	<b>CO/BO: Multi-pump control bypass command / Mpc bypass cmd</b>	<b>Access level:</b> 3	<b>Calculated:</b> -	<b>Data type:</b> Unsigned32
		<b>Can be changed:</b> -	<b>Scaling:</b> -	<b>Dynamic index:</b> -
		<b>Unit group:</b> -	<b>Unit selection:</b> -	<b>Function diagram:</b> -
		<b>Min:</b>	<b>Max:</b>	<b>Factory setting:</b>
		-	-	-
<b>Description:</b>	Displays the signal source for the control command to the bypass. It is BiCo to p1266.			
	<b>Note</b>			
	The "Bypass" function switches the motor between inverter and line operation.			
<b>p29546</b>	<b>Multi-pump control deviation threshold / Mpc devia thres</b>	<b>Access level:</b> 3	<b>Calculated:</b> -	<b>Data type:</b> FloatingPoint32
		<b>Can be changed:</b> T, U	<b>Scaling:</b> PERCENT	<b>Dynamic index:</b> -
		<b>Unit group:</b> -	<b>Unit selection:</b> -	<b>Function diagram:</b> -
		<b>Min:</b>	<b>Max:</b>	<b>Factory setting:</b>
		0.00 [%]	100.00 [%]	20.00 [%]
<b>Description:</b>	If the system deviation (p2273) at the PID technology controller exceeds the threshold (p29546) and no more motor is available, alarm A52963 occurs.			
<b>p29547[0...3]</b>	<b>Multi-pump control continuous operating hours / Mpc Conti_oper_hrs</b>	<b>Access level:</b> 3	<b>Calculated:</b> -	<b>Data type:</b> FloatingPoint32
		<b>Can be changed:</b> T, U	<b>Scaling:</b> -	<b>Dynamic index:</b> -
		<b>Unit group:</b> -	<b>Unit selection:</b> -	<b>Function diagram:</b> -
		<b>Min:</b>	<b>Max:</b>	<b>Factory setting:</b>
		0.00 [h]	1000000.00 [h]	0.00 [h]
<b>Description:</b>	Displays the continuous operating hours for the motors. The display can only be reset to zero.			
<b>Index:</b>	[0] = motor 1 operating hours [1] = motor 2 operating hours [2] = motor 3 operating hours [3] = motor 4 operating hours			
	<b>Note</b>			
	Continuous operation is measured starting from when a motor is ON. It ends when a motor is OFF.			
<b>r29549</b>	<b>CO/BO: Multi-pump control feedback signal for contactor / Mpc fdb signal</b>	<b>Access level:</b> 3	<b>Calculated:</b> -	<b>Data type:</b> Unsigned32
		<b>Can be changed:</b> -	<b>Scaling:</b> -	<b>Dynamic index:</b> -
		<b>Unit group:</b> -	<b>Unit selection:</b> -	<b>Function diagram:</b> -
		<b>Min:</b>	<b>Max:</b>	<b>Factory setting:</b>
		-	-	-
<b>Description:</b>	Bico to p1269[0] as a feedback signal			
<b>p29570[0...n]</b>	<b>Ramp-up scaling 1 / RmpUpScaling1</b>	<b>Access level:</b> 3	<b>Calculated:</b> -	<b>Data type:</b> FloatingPoint32
		<b>Can be changed:</b> T	<b>Scaling:</b> -	<b>Dynamic index:</b> DDS, p0180
		<b>Unit group:</b> -	<b>Unit selection:</b> -	<b>Function diagram:</b> -
		<b>Min:</b>	<b>Max:</b>	<b>Factory setting:</b>
		0.00 [%]	9999999.00 [%]	100.00 [%]
<b>Description:</b>	Sets the ramp-up scaling 1 for the dual ramp function [%].			

<b>p29571[0...n]</b>	<b>Threshold speed 2 / Thresh_2_Ramp</b>		
	<b>Access level:</b> 3	<b>Calculated:</b> -	<b>Data type:</b> FloatingPoint32
	<b>Can be changed:</b> T	<b>Scaling:</b> p2000	<b>Dynamic index:</b> DDS, p0180
	<b>Unit group:</b> 3_1	<b>Unit selection:</b> p0505	<b>Function diagram:</b> -
	<b>Min:</b> 0.00 [rpm]	<b>Max:</b> 210000.00 [rpm]	<b>Factory setting:</b> 30.00 [rpm]
<b>Description:</b>	Defines the threshold 2 for comparing the speed actual value with the speed threshold.		
<b>p29572[0...n]</b>	<b>Ramp-up scaling 2 / RmpUpScaling2</b>		
	<b>Access level:</b> 3	<b>Calculated:</b> -	<b>Data type:</b> FloatingPoint32
	<b>Can be changed:</b> T	<b>Scaling:</b> -	<b>Dynamic index:</b> DDS, p0180
	<b>Unit group:</b> -	<b>Unit selection:</b> -	<b>Function diagram:</b> -
	<b>Min:</b> 0.00 [%]	<b>Max:</b> 9999999.00 [%]	<b>Factory setting:</b> 100.00 [%]
<b>Description:</b>	Sets the ramp-up scaling 2 for the dual ramp function [%].		
<b>p29573[0...n]</b>	<b>Ramp-down scaling 1 / RmpDnScaling1</b>		
	<b>Access level:</b> 3	<b>Calculated:</b> -	<b>Data type:</b> FloatingPoint32
	<b>Can be changed:</b> T	<b>Scaling:</b> -	<b>Dynamic index:</b> DDS, p0180
	<b>Unit group:</b> -	<b>Unit selection:</b> -	<b>Function diagram:</b> -
	<b>Min:</b> 0.00 [%]	<b>Max:</b> 9999999.00 [%]	<b>Factory setting:</b> 100.00 [%]
<b>Description:</b>	Defines the ramp-down scaling 1 for the dual ramp function [%].		
<b>p29574[0...n]</b>	<b>Threshold speed 3 / Thresh_3_Ramp</b>		
	<b>Access level:</b> 3	<b>Calculated:</b> -	<b>Data type:</b> FloatingPoint32
	<b>Can be changed:</b> T	<b>Scaling:</b> p2000	<b>Dynamic index:</b> DDS, p0180
	<b>Unit group:</b> 3_1	<b>Unit selection:</b> p0505	<b>Function diagram:</b> -
	<b>Min:</b> 0.00 [rpm]	<b>Max:</b> 210000.00 [rpm]	<b>Factory setting:</b> 30.00 [rpm]
<b>Description:</b>	Defines the threshold 3 for comparing the speed actual value to the speed threshold.		
<b>p29575[0...n]</b>	<b>Ramp-down scaling 2 / RmpDnScaling2</b>		
	<b>Access level:</b> 3	<b>Calculated:</b> -	<b>Data type:</b> FloatingPoint32
	<b>Can be changed:</b> T	<b>Scaling:</b> -	<b>Dynamic index:</b> DDS, p0180
	<b>Unit group:</b> -	<b>Unit selection:</b> -	<b>Function diagram:</b> -
	<b>Min:</b> 0.00 [%]	<b>Max:</b> 9999999.00 [%]	<b>Factory setting:</b> 100.00 [%]
<b>Description:</b>	Sets the ramp-down scaling 2 for dual ramp function [%].		
<b>r29576</b>	<b>CO: Ramp-up scaling output / RmpUpSca</b>		
	<b>Access level:</b> 3	<b>Calculated:</b> -	<b>Data type:</b> FloatingPoint32
	<b>Can be changed:</b> -	<b>Scaling:</b> PERCENT	<b>Dynamic index:</b> -
	<b>Unit group:</b> -	<b>Unit selection:</b> -	<b>Function diagram:</b> -
	<b>Min:</b> - [%]	<b>Max:</b> - [%]	<b>Factory setting:</b> - [%]
<b>Description:</b>	Displays the actual output of the ramp-up scaling.		

<b>r29577</b>	<b>CO: Ramp-down scaling output / RmpDnSca</b>		
	<b>Access level:</b> 3	<b>Calculated:</b> -	<b>Data type:</b> FloatingPoint32
	<b>Can be changed:</b> -	<b>Scaling:</b> PERCENT	<b>Dynamic index:</b> -
	<b>Unit group:</b> -	<b>Unit selection:</b> -	<b>Function diagram:</b> -
	<b>Min:</b> - [%]	<b>Max:</b> - [%]	<b>Factory setting:</b> - [%]
<b>Description:</b>	Displays the actual output of the ramp-down scaling.		
<b>p29578[0...n]</b>	<b>CI: Ramp-up scaling input / Rup scale input</b>		
	<b>Access level:</b> 3	<b>Calculated:</b> -	<b>Data type:</b> Unsigned32 / FloatingPoint32
	<b>Can be changed:</b> T	<b>Scaling:</b> PERCENT	<b>Dynamic index:</b> CDS, p0170
	<b>Unit group:</b> -	<b>Unit selection:</b> -	<b>Function diagram:</b> -
	<b>Min:</b> -	<b>Max:</b> -	<b>Factory setting:</b> 1
<b>Description:</b>	Sets the signal source for scaling the ramp-up time of the ramp-function generator when p1138 is BICO to r29576. When the dual ramp functionality is not enabled, p29578 will function.		
<b>p29579[0...n]</b>	<b>CI: Ramp-down scaling input / Rdown scale input</b>		
	<b>Access level:</b> 3	<b>Calculated:</b> -	<b>Data type:</b> Unsigned32 / FloatingPoint32
	<b>Can be changed:</b> T	<b>Scaling:</b> PERCENT	<b>Dynamic index:</b> CDS, p0170
	<b>Unit group:</b> -	<b>Unit selection:</b> -	<b>Function diagram:</b> -
	<b>Min:</b> -	<b>Max:</b> -	<b>Factory setting:</b> 1
<b>Description:</b>	Sets the signal source for scaling the ramp-down time of the ramp-function generator when p1139 is BICO to r29577. When the dual ramp functionality is not enabled, p29579 will function.		
<b>p29580[0...n]</b>	<b>BI: Dual ramp enable / DuRamp En</b>		
	<b>Access level:</b> 3	<b>Calculated:</b> -	<b>Data type:</b> Unsigned32 / Binary
	<b>Can be changed:</b> T	<b>Scaling:</b> -	<b>Dynamic index:</b> CDS, p0170
	<b>Unit group:</b> -	<b>Unit selection:</b> -	<b>Function diagram:</b> -
	<b>Min:</b> -	<b>Max:</b> -	<b>Factory setting:</b> 0
<b>Description:</b>	Sets the signal source to enable the dual ramp function.		
<b>p29590[0...n]</b>	<b>Deragging mode / Derag mod</b>		
	<b>Access level:</b> 3	<b>Calculated:</b> -	<b>Data type:</b> Integer16
	<b>Can be changed:</b> T	<b>Scaling:</b> -	<b>Dynamic index:</b> DDS, p0180
	<b>Unit group:</b> -	<b>Unit selection:</b> -	<b>Function diagram:</b> -
	<b>Min:</b> 0	<b>Max:</b> 3	<b>Factory setting:</b> 0
<b>Description:</b>	Select the startup mode of deragging, if the condition is met with selected mode, deragging will perform when drive start to run, then switch to user setpoint automatically.		
<b>Value:</b>	0: deragging disable 1: enabled on first run after power up 2: enabled on every run 3: enabled by BI input		

## 7.3 Parameter list

**Note**

If deragging is enabled (P29590 > 0), make sure that reverse direction is not inhibited, i.e. P1110 = 0;  
If P29590=3, enable source is defined by P29591.

<b>p29591[0...n]</b>	<b>BI: Deragging enable / Derag en</b>	<b>Calculated:</b> -	<b>Data type:</b> Unsigned32 / Binary
	<b>Access level:</b> 3	<b>Scaling:</b> -	<b>Dynamic index:</b> CDS, p0170
	<b>Can be changed:</b> T	<b>Unit selection:</b> -	<b>Function diagram:</b> -
	<b>Unit group:</b> -	<b>Max:</b>	<b>Factory setting:</b>
	<b>Min:</b>	-	0
<b>Description:</b>	The source of deragging enable.		
	<b>Note</b>		
	Effective only if mode set as BI input(p29590=3).		
<b>p29592[0...n]</b>	<b>Deragging forward speed / Derag fw spd</b>	<b>Calculated:</b> -	<b>Data type:</b> FloatingPoint32
	<b>Access level:</b> 3	<b>Scaling:</b> -	<b>Dynamic index:</b> DDS, p0180
	<b>Can be changed:</b> T	<b>Unit selection:</b> p0505	<b>Function diagram:</b> -
	<b>Unit group:</b> 3_1	<b>Max:</b>	<b>Factory setting:</b>
	<b>Min:</b>	-210000.00 [rpm]	500.00 [rpm]
		210000.00 [rpm]	
<b>Description:</b>	Defines forward speed setpoint for deragging.		
	<b>Note</b>		
	The actual speed setpoint is limited by minimal(P1080) and maximum(P1082) value. If both forward speed(P29592) and the time of duration(P29596) are 0, forward rotation will not perform in each cycle.		
<b>p29593[0...n]</b>	<b>Deragging reverse speed / Derag rev spd</b>	<b>Calculated:</b> -	<b>Data type:</b> FloatingPoint32
	<b>Access level:</b> 3	<b>Scaling:</b> -	<b>Dynamic index:</b> DDS, p0180
	<b>Can be changed:</b> T	<b>Unit selection:</b> p0505	<b>Function diagram:</b> -
	<b>Unit group:</b> 3_1	<b>Max:</b>	<b>Factory setting:</b>
	<b>Min:</b>	-210000.00 [rpm]	500.00 [rpm]
		210000.00 [rpm]	
<b>Description:</b>	Defines reverse speed setpoint for deragging.		
	<b>Note</b>		
	The actual speed setpoint is limited by minimal(P1080) and maximum(P1082) value. If both reverse speed(P29593) and the time of duration(P29597) are 0, reverse rotation will not perform in each cycle.		
<b>p29594[0...n]</b>	<b>Deragging ramp up time / Derag rup</b>	<b>Calculated:</b> -	<b>Data type:</b> FloatingPoint32
	<b>Access level:</b> 3	<b>Scaling:</b> -	<b>Dynamic index:</b> DDS, p0180
	<b>Can be changed:</b> T	<b>Unit selection:</b> -	<b>Function diagram:</b> -
	<b>Unit group:</b> -	<b>Max:</b>	<b>Factory setting:</b>
	<b>Min:</b>	0.00 [s]	5.00 [s]
		1000.00 [s]	
<b>Description:</b>	Defines ramp time from 0 to forward/reverse speed setpoint for deragging.		
	<b>Note</b>		
	Too short ramp up time for deragging may trigger F7902, and speed jump may occur. The minimal time is upon the inertia of motor and power stage.		

<b>p29595[0...n]</b>	<b>Deragging ramp down time / Derag rdn</b>		
	<b>Access level:</b> 3	<b>Calculated:</b> -	<b>Data type:</b> FloatingPoint32
	<b>Can be changed:</b> T	<b>Scaling:</b> -	<b>Dynamic index:</b> DDS, p0180
	<b>Unit group:</b> -	<b>Unit selection:</b> -	<b>Function diagram:</b> -
	<b>Min:</b> 0.00 [s]	<b>Max:</b> 1000.00 [s]	<b>Factory setting:</b> 5.00 [s]
<b>Description:</b>	Defines ramp time from forward/reverse speed setpoint to 0 for deragging.		
	<b>Note</b> Speed jump may occur if ramp down time is too short, and that may trigger the fault of DC-link overvoltage. The minimal time is upon the inertia of motor and power stage.		
<b>p29596[0...n]</b>	<b>Deragging forward time / Derag fw time</b>		
	<b>Access level:</b> 3	<b>Calculated:</b> -	<b>Data type:</b> FloatingPoint32
	<b>Can be changed:</b> T	<b>Scaling:</b> -	<b>Dynamic index:</b> DDS, p0180
	<b>Unit group:</b> -	<b>Unit selection:</b> -	<b>Function diagram:</b> -
	<b>Min:</b> 0.00 [s]	<b>Max:</b> 1000.00 [s]	<b>Factory setting:</b> 5.00 [s]
<b>Description:</b>	Defines the duration time at each forward speed for deragging.		
<b>p29597[0...n]</b>	<b>Deragging reverse time / Derag rev tim</b>		
	<b>Access level:</b> 3	<b>Calculated:</b> -	<b>Data type:</b> FloatingPoint32
	<b>Can be changed:</b> T	<b>Scaling:</b> -	<b>Dynamic index:</b> DDS, p0180
	<b>Unit group:</b> -	<b>Unit selection:</b> -	<b>Function diagram:</b> -
	<b>Min:</b> 0.00 [s]	<b>Max:</b> 1000.00 [s]	<b>Factory setting:</b> 5.00 [s]
<b>Description:</b>	Defines the duration time at reverse speed for deragging.		
<b>p29598[0...n]</b>	<b>Number of deragging cycles / Derag cycs</b>		
	<b>Access level:</b> 3	<b>Calculated:</b> -	<b>Data type:</b> Unsigned32
	<b>Can be changed:</b> T	<b>Scaling:</b> -	<b>Dynamic index:</b> DDS, p0180
	<b>Unit group:</b> -	<b>Unit selection:</b> -	<b>Function diagram:</b> -
	<b>Min:</b> 1	<b>Max:</b> 999	<b>Factory setting:</b> 1
<b>Description:</b>	The number of the deragging cycle is repeated		
<b>p29610[0...n]</b>	<b>Pipe filling enable / PF En</b>		
	<b>Access level:</b> 3	<b>Calculated:</b> -	<b>Data type:</b> Integer16
	<b>Can be changed:</b> T	<b>Scaling:</b> -	<b>Dynamic index:</b> DDS, p0180
	<b>Unit group:</b> -	<b>Unit selection:</b> -	<b>Function diagram:</b> -
	<b>Min:</b> 0	<b>Max:</b> 1	<b>Factory setting:</b> 0
<b>Description:</b>	Enable the pipe filling function.		
<b>Value:</b>	0: The pipe filling function is disabled 1: The pipe filling function is enabled		
	<b>Note</b> The pipe filling function allows the inverter to fill an empty pipe slowly when the inverter works for the first time after each power-up.		

## 7.3 Parameter list

<b>p29611[0...n]</b>	<b>Pipe filling mode / PF mode</b>		
	<b>Access level:</b> 3	<b>Calculated:</b> -	<b>Data type:</b> Integer16
	<b>Can be changed:</b> T	<b>Scaling:</b> -	<b>Dynamic index:</b> DDS, p0180
	<b>Unit group:</b> -	<b>Unit selection:</b> -	<b>Function diagram:</b> -
	<b>Min:</b> 0	<b>Max:</b> 1	<b>Factory setting:</b> 0
<b>Description:</b>	Selects the mode for pipe filling.		
<b>Value:</b>	0: The pipe is filled based on specified time 1: The pipe is filled based on the actual pressure feedback		
<b>p29612[0...n]</b>	<b>Pipe filling speed / PF spd</b>		
	<b>Access level:</b> 3	<b>Calculated:</b> -	<b>Data type:</b> FloatingPoint32
	<b>Can be changed:</b> T	<b>Scaling:</b> p2000	<b>Dynamic index:</b> DDS, p0180
	<b>Unit group:</b> 3_1	<b>Unit selection:</b> p0505	<b>Function diagram:</b> -
	<b>Min:</b> -210000.00 [rpm]	<b>Max:</b> 210000.00 [rpm]	<b>Factory setting:</b> 900.00 [rpm]
<b>Description:</b>	Sets the speed applied to the motor for the pipe filling.		
<b>p29613[0...n]</b>	<b>Pipe filling time / PF time</b>		
	<b>Access level:</b> 3	<b>Calculated:</b> -	<b>Data type:</b> FloatingPoint32
	<b>Can be changed:</b> T	<b>Scaling:</b> -	<b>Dynamic index:</b> DDS, p0180
	<b>Unit group:</b> -	<b>Unit selection:</b> -	<b>Function diagram:</b> -
	<b>Min:</b> 0.50 [s]	<b>Max:</b> 10000.00 [s]	<b>Factory setting:</b> 50.00 [s]
<b>Description:</b>	Sets the duration time for the pipe filling.		
<b>p29614[0...n]</b>	<b>Pipe filling threshold / PF thresh</b>		
	<b>Access level:</b> 3	<b>Calculated:</b> -	<b>Data type:</b> FloatingPoint32
	<b>Can be changed:</b> T	<b>Scaling:</b> -	<b>Dynamic index:</b> DDS, p0180
	<b>Unit group:</b> 9_1	<b>Unit selection:</b> p0595	<b>Function diagram:</b> -
	<b>Min:</b> 0.00 [%]	<b>Max:</b> 100.00 [%]	<b>Factory setting:</b> 10.00 [%]
<b>Description:</b>	Defines the threshold for stopping the pipe filling. The filling stops if the actual PID feedback reaches the threshold. It's used when p29611=1.		
<b>p29615[0...n]</b>	<b>Pipe filling monitoring time / PF mon time</b>		
	<b>Access level:</b> 3	<b>Calculated:</b> -	<b>Data type:</b> FloatingPoint32
	<b>Can be changed:</b> T	<b>Scaling:</b> -	<b>Dynamic index:</b> DDS, p0180
	<b>Unit group:</b> -	<b>Unit selection:</b> -	<b>Function diagram:</b> -
	<b>Min:</b> 0.00 [s]	<b>Max:</b> 100.00 [s]	<b>Factory setting:</b> 0.00 [s]
<b>Description:</b>	Monitors the duration time for actual pressure (r2272) >= the threshold (p29614). The pipe filling stops if the duration time is reached.		
	<b>Note</b> It is used when p29611 = 1.		



<b>p29622[0...n]</b>	<b>BI: Frost protection enable / Fro en</b>	<b>Access level:</b> 3	<b>Calculated:</b> -	<b>Data type:</b> Unsigned32 / Binary
		<b>Can be changed:</b> T, U	<b>Scaling:</b> -	<b>Dynamic index:</b> CDS, p0170
		<b>Unit group:</b> -	<b>Unit selection:</b> -	<b>Function diagram:</b> -
		<b>Min:</b>	<b>Max:</b>	<b>Factory setting:</b>
		-	-	0

**Description:** Sets the signal source to enable frost protection. If the binary input is equal to 1, then protection will be initiated. If the inverter is stopped and the protection signal becomes active, protection measure is applied as follows:

- If p29623 != 0, frost protection is activated by applying the specified speed to the motor;
- If p29623 = 0, and p29624 != 0, condensation protection is activated by applying the specified current to the motor.

**Note**

The protection function may be overridden under the following conditions:

- If the inverter is running and the protection signal becomes active, the signal is ignored.
- If the inverter is turning a motor due to active protection signal and a RUN command is received, RUN command overrides the frost protection signal.
- Issuing an OFF command while protection is active will stop the motor.

<b>p29623[0...n]</b>	<b>Frost protection speed / Fro spd</b>	<b>Access level:</b> 3	<b>Calculated:</b> -	<b>Data type:</b> FloatingPoint32
		<b>Can be changed:</b> T, U	<b>Scaling:</b> p2000	<b>Dynamic index:</b> DDS, p0180
		<b>Unit group:</b> 3_1	<b>Unit selection:</b> p0505	<b>Function diagram:</b> -
		<b>Min:</b>	<b>Max:</b>	<b>Factory setting:</b>
		-210000.000 [rpm]	210000.000 [rpm]	0.000 [rpm]

**Description:** Specifies the speed applied to the motor when frost protection is active.  
And this parameter can't be changed when the frost or condensation function is active.

**Dependency:** See also p29622.

<b>p29624[0...n]</b>	<b>Condensation protection current / Cond current</b>	<b>Access level:</b> 3	<b>Calculated:</b> -	<b>Data type:</b> FloatingPoint32
		<b>Can be changed:</b> T, U	<b>Scaling:</b> -	<b>Dynamic index:</b> DDS, p0180
		<b>Unit group:</b> -	<b>Unit selection:</b> -	<b>Function diagram:</b> -
		<b>Min:</b>	<b>Max:</b>	<b>Factory setting:</b>
		0.000 [%]	100.000 [%]	30.000 [%]

**Description:** Specifies the DC current (as a percentage of rated current) applied to the motor when condensation protection is active.

**Dependency:** See also p29622.

**Note**

The change to the current becomes effective the next time condensation protection is active.

<b>p29625[0...n]</b>	<b>Cavitation protection enable / Cavi en</b>	<b>Access level:</b> 3	<b>Calculated:</b> -	<b>Data type:</b> Integer16
		<b>Can be changed:</b> T, U	<b>Scaling:</b> -	<b>Dynamic index:</b> DDS, p0180
		<b>Unit group:</b> -	<b>Unit selection:</b> -	<b>Function diagram:</b> -
		<b>Min:</b>	<b>Max:</b>	<b>Factory setting:</b>
		0	2	0

**Description:** Enables the cavitation protection function. A fault/alarm is generated when cavitation conditions are deemed to be present.

**Value:**

- 0: The cavitation protection function is deactivated
- 1: The cavitation protection function triggers fault F52960
- 2: The cavitation protection function triggers warning A52961

<b>p29626[0...n]</b>	<b>Cavitation protection threshold / Cavi thresh</b>		
	<b>Access level:</b> 3	<b>Calculated:</b> -	<b>Data type:</b> FloatingPoint32
	<b>Can be changed:</b> T, U	<b>Scaling:</b> -	<b>Dynamic index:</b> DDS, p0180
	<b>Unit group:</b> 9_1	<b>Unit selection:</b> p0595	<b>Function diagram:</b> -
	<b>Min:</b> 0.00 [%]	<b>Max:</b> 200.00 [%]	<b>Factory setting:</b> 40.00 [%]
<b>Description:</b>	Defines the feedback threshold (as a percentage) for triggering a fault/alarm.		
<b>p29627[0...n]</b>	<b>Cavitation protection time / Cavi time</b>		
	<b>Access level:</b> 3	<b>Calculated:</b> -	<b>Data type:</b> Unsigned16
	<b>Can be changed:</b> T, U	<b>Scaling:</b> -	<b>Dynamic index:</b> DDS, p0180
	<b>Unit group:</b> -	<b>Unit selection:</b> -	<b>Function diagram:</b> -
	<b>Min:</b> 1 [s]	<b>Max:</b> 65000 [s]	<b>Factory setting:</b> 30 [s]
<b>Description:</b>	Sets the time for which cavitation conditions have to be present before a fault/alarm is triggered.		
<b>r29629</b>	<b>CO/BO: Status word: application / Stat application</b>		
	<b>Access level:</b> 3	<b>Calculated:</b> -	<b>Data type:</b> Unsigned32
	<b>Can be changed:</b> -	<b>Scaling:</b> -	<b>Dynamic index:</b> -
	<b>Unit group:</b> -	<b>Unit selection:</b> -	<b>Function diagram:</b> -
	<b>Min:</b> -	<b>Max:</b> -	<b>Factory setting:</b> -
<b>Description:</b>	Displays the status word for application: bit 0: = 1, pipe filling is active; = 0, pipe filling is not active. bit 2/1: = 0/1, condensation protection is active; = 1/1, frost protection is active; = 0/0, frost and condensation protections are not active; = 1/0, not used.		
<b>p29630</b>	<b>Keep-running operation enable / KeepRun</b>		
	<b>Access level:</b> 3	<b>Calculated:</b> -	<b>Data type:</b> Unsigned16
	<b>Can be changed:</b> T	<b>Scaling:</b> -	<b>Dynamic index:</b> -
	<b>Unit group:</b> -	<b>Unit selection:</b> -	<b>Function diagram:</b> -
	<b>Min:</b> 0	<b>Max:</b> 1	<b>Factory setting:</b> 0
<b>Description:</b>	Sets the signal source to enable inverter keep-running operation. This attempts to prevent the inverter from tripping by enabling all possible existing de-rating features and the automatic restart function.		

**Note**

p29630 = 1

Sets the following parameter values to minimize likelihood of a trip:

p0290 = 2 (inverter overload reaction: reduce pulse frequency, output current and output frequency)

p1210 = 4 (restart after line supply failure without additional start attempts)

P1211 = 10 (number of times inverter will attempt to restart)

p1240 = 2 and p1280 = 2 (configuration of Vdc controller: Vdc\_max controller and kinetic buffering (KIB) enabled)

p29630 = 0

Resets the parameters to their default values:

p0290 = 2 (inverter overload reaction: reduce pulse frequency, output current and output frequency)

p1210 = 0 (automatic restart function: trip reset after power on, p1211 disabled)

p1211 = 3 (number of times inverter will attempt to restart)

p1240 = 1 and p1280 = 1(configuration of Vdc controller: Vdc\_max controller enabled)

<b>p29631[0...4]</b>	<b>Flow meter pump power / FlowM_power</b>			
	<b>Access level:</b> 3	<b>Calculated:</b> -	<b>Data type:</b> FloatingPoint32	
	<b>Can be changed:</b> T, U	<b>Scaling:</b> -	<b>Dynamic index:</b> -	
	<b>Unit group:</b> -	<b>Unit selection:</b> -	<b>Function diagram:</b> -	
	<b>Min:</b> 0.00 [kW]	<b>Max:</b> 340.28235E36 [kW]	<b>Factory setting:</b> 0.00 [kW]	
<b>Description:</b>	Determines the power points for flow estimation. Five power values are put into the indexes of this parameter. These values should be spread across the full power range of the inverter. User should guarantee values in all indexes is increasing in sequence (p29631[0] <= p29631 [1] <= p29631[2] <= ...). Otherwise the calculated flow value will be 0.			
<b>p29632[0...4]</b>	<b>Flow meter pump flow / FlowM_flow</b>			
	<b>Access level:</b> 3	<b>Calculated:</b> -	<b>Data type:</b> FloatingPoint32	
	<b>Can be changed:</b> T, U	<b>Scaling:</b> -	<b>Dynamic index:</b> -	
	<b>Unit group:</b> -	<b>Unit selection:</b> -	<b>Function diagram:</b> -	
	<b>Min:</b> 0.00 [m³/h]	<b>Max:</b> 340.28235E36 [m³/h]	<b>Factory setting:</b> 0.00 [m³/h]	
<b>Description:</b>	Determines the flow for the corresponding pump power point used for flow estimation. Five corresponding flow values should be entered derived from the manufacturer's pump characteristic curve.			
<b>r29633</b>	<b>Flow meter calculated flow / FlowM_calc flow</b>			
	<b>Access level:</b> 3	<b>Calculated:</b> -	<b>Data type:</b> FloatingPoint32	
	<b>Can be changed:</b> -	<b>Scaling:</b> -	<b>Dynamic index:</b> -	
	<b>Unit group:</b> -	<b>Unit selection:</b> -	<b>Function diagram:</b> -	
	<b>Min:</b> - [m³/h]	<b>Max:</b> - [m³/h]	<b>Factory setting:</b> - [m³/h]	
<b>Description:</b>	The calculation result of flow meter.			
<b>r29640.0...18</b>	<b>CO/BO: Extended setpoint channel selection output / Setp selection</b>			
	<b>Access level:</b> 3	<b>Calculated:</b> -	<b>Data type:</b> Unsigned32	
	<b>Can be changed:</b> -	<b>Scaling:</b> -	<b>Dynamic index:</b> -	
	<b>Unit group:</b> -	<b>Unit selection:</b> -	<b>Function diagram:</b> -	
	<b>Min:</b> -	<b>Max:</b> -	<b>Factory setting:</b> -	
<b>Description:</b>	Displays the actual output of the extended setpoint channel selection.			
<b>Bit field:</b>	<b>Bit</b>	<b>Signal name</b>	<b>1 signal</b>	<b>0 signal</b> <b>FP</b>

Parameters

7.3 Parameter list

00	Extend speed setpoint selected	1	0	-
01	Frost or condensation executing	1	0	-
03	Deragging executing	1	0	-
04	Pipe filling executing	1	0	-
05	Total executing	1	0	-
06	Normal executing	1	0	-
16	Ramp up status	1	0	-
17	Ramp down status	1	0	-
18	Target setpoint reached flag	1	0	-

---

**r29641**      **CO: Extended setpoint channel setpoint output / Setp output**

<b>Access level:</b> 3	<b>Calculated:</b> -	<b>Data type:</b> FloatingPoint32
<b>Can be changed:</b> -	<b>Scaling:</b> p2000	<b>Dynamic index:</b> -
<b>Unit group:</b> 3_1	<b>Unit selection:</b> p0505	<b>Function diagram:</b> -
<b>Min:</b> - [rpm]	<b>Max:</b> - [rpm]	<b>Factory setting:</b> - [rpm]

**Description:**      Displays the actual output of the extended setpoint channel setpoint.

---

**p29642**      **BI: Ramp-function generator, accept setpoint / Total setp sel**

<b>Access level:</b> 3	<b>Calculated:</b> -	<b>Data type:</b> Unsigned32 / Binary
<b>Can be changed:</b> T	<b>Scaling:</b> -	<b>Dynamic index:</b> -
<b>Unit group:</b> -	<b>Unit selection:</b> -	<b>Function diagram:</b> -
<b>Min:</b> -	<b>Max:</b> -	<b>Factory setting:</b> 0

**Description:**      Sets the signal source for accepting the setpoint of the ramp-function generator.

---

**p29643**      **CI: Ramp-function generator setpoint input / Total Setpoint**

<b>Access level:</b> 3	<b>Calculated:</b> -	<b>Data type:</b> Unsigned32 / FloatingPoint32
<b>Can be changed:</b> T	<b>Scaling:</b> p2000	<b>Dynamic index:</b> -
<b>Unit group:</b> -	<b>Unit selection:</b> -	<b>Function diagram:</b> -
<b>Min:</b> -	<b>Max:</b> -	<b>Factory setting:</b> 0

**Description:**      Sets the signal source for inputting the setpoint of the ramp-function generator.

---

**p29650[0...n]**      **DI selection for ON/OFF2 / DI sel ON/OFF2**

<b>Access level:</b> 3	<b>Calculated:</b> -	<b>Data type:</b> Integer16
<b>Can be changed:</b> T	<b>Scaling:</b> -	<b>Dynamic index:</b> CDS, p0170
<b>Unit group:</b> -	<b>Unit selection:</b> -	<b>Function diagram:</b> -
<b>Min:</b> -1	<b>Max:</b> 5	<b>Factory setting:</b> 0

**Description:**      Defines the DI selection for ON/OFF2. After setting, configuration will be done internally(Except DP/PN variants),  
p0840[0...n] = r29659.0  
p0844[0...n] = r29659.1  
p29652[0...n] = 722.n  
You can also configure p29651[0...n] and p29652[0...n] after setting p29650[0...n].  
Similar to p0840[0...n] and p0844[0...n], p29651[0...n] and p29652[0...n] are for ON/OFF1 input and OFF2 input respectively.

**Value:**      -1:      NONE

0:	DI0
1:	DI1
2:	DI2
3:	DI3
4:	DI4
5:	DI5

**Note**

On variants with PN/DP interface , when ON/OFF2 enabled(p29650>=0), the configuration of p840 and p844 will not be updated internally. ON/OFF2 is only effective if both are configured as r29659 bit0 and bit1 respectively.

<b>p29651[0...n]</b>	<b>BI: ON/OFF1 (OFF1) / ON/OFF1 (OFF1)</b>		
	<b>Access level:</b> 3	<b>Calculated:</b> -	<b>Data type:</b> Unsigned32 / Binary
	<b>Can be changed:</b> T	<b>Scaling:</b> -	<b>Dynamic index:</b> CDS, p0170
	<b>Unit group:</b> -	<b>Unit selection:</b> -	<b>Function diagram:</b> -
	<b>Min:</b>	<b>Max:</b>	<b>Factory setting:</b>
	-	-	0

**Description:** Sets the signal source for the command "ON/OFF1 (OFF1)".

<b>p29652[0...n]</b>	<b>BI: ON/OFF2 (OFF2) / ON/OFF2 (OFF2)</b>		
	<b>Access level:</b> 3	<b>Calculated:</b> -	<b>Data type:</b> Unsigned32 / Binary
	<b>Can be changed:</b> T	<b>Scaling:</b> -	<b>Dynamic index:</b> CDS, p0170
	<b>Unit group:</b> -	<b>Unit selection:</b> -	<b>Function diagram:</b> -
	<b>Min:</b>	<b>Max:</b>	<b>Factory setting:</b>
	-	-	722.0

**Description:** Sets the signal source for the command "ON/OFF2 (OFF2)".

<b>r29659</b>	<b>CO/BO: Status word:command / Cmd stat</b>		
	<b>Access level:</b> 3	<b>Calculated:</b> -	<b>Data type:</b> Unsigned32
	<b>Can be changed:</b> -	<b>Scaling:</b> -	<b>Dynamic index:</b> -
	<b>Unit group:</b> -	<b>Unit selection:</b> -	<b>Function diagram:</b> -
	<b>Min:</b>	<b>Max:</b>	<b>Factory setting:</b>
	-	-	-

**Description:** Command status is for ON/OFF1, OFF2 which can connect to p0840, p0844.

<b>p60000</b>	<b>PROFIdrive reference speed reference frequency / PD n_ref f_ref</b>		
	<b>Access level:</b> 2	<b>Calculated:</b> CALC_MOD_ALL	<b>Data type:</b> FloatingPoint32
	<b>Can be changed:</b> T	<b>Scaling:</b> -	<b>Dynamic index:</b> -
	<b>Unit group:</b> -	<b>Unit selection:</b> -	<b>Function diagram:</b> -
	<b>Min:</b>	<b>Max:</b>	<b>Factory setting:</b>
	6.00 [rpm]	210000.00 [rpm]	1500.00 [rpm]

**Description:** Sets the reference quantity for speed and frequency.  
All speeds or frequencies specified as relative value are referred to this reference quantity.  
The reference quantity corresponds to 100% or 4000 hex (word) or 4000 0000 hex (double word).  
The following applies: reference frequency (in Hz) = reference speed (in ((rpm) / 60) x pole pair number)

**Dependency:** See also: p2000

**NOTICE**

When the reference speed / reference frequency is changed, short-term communication interruptions may occur.

7.3 Parameter list

**Note**

Parameter p60000 is an image of parameter p2000 in conformance with PROFIdrive. A change always effects both parameters.

If a BICO interconnection is established between different physical quantities, then the particular reference quantities are used as internal conversion factor.

Example:

The setpoint from PROFIBUS (r2050[1]) is connected to a speed setpoint (e.g. p1070[0]). The actual input value is cyclically converted into a percentage value via the pre-specified scaling 4000 hex. This percentage value is converted to the absolute speed setpoint using the reference speed (p60000).

The setpoint from PROFIBUS (r2060[1]) is connected to a speed setpoint (e.g. p1155[0]). The actual input value is cyclically converted into a percentage value via the pre-specified scaling 4000 0000 hex. This percentage value is converted to the absolute speed setpoint using the reference speed (p60000).

<b>r61000[0...239]</b>	<b>PROFINET Name of Station / PN Name of Station</b>		
	<b>Access level:</b> 3	<b>Calculated:</b> -	<b>Data type:</b> Unsigned8
	<b>Can be changed:</b> -	<b>Scaling:</b> -	<b>Dynamic index:</b> -
	<b>Unit group:</b> -	<b>Unit selection:</b> -	<b>Function diagram:</b> 2410
	<b>Min:</b> -	<b>Max:</b> -	<b>Factory setting:</b> -

**Description:** Displays PROFINET Name of Station.

<b>NOTICE</b>
An ASCII table (excerpt) can be found, for example, in the chapter of parameters.

<b>r61001[0...3]</b>	<b>PROFINET IP of Station / PN IP of Station</b>		
	<b>Access level:</b> 3	<b>Calculated:</b> -	<b>Data type:</b> Unsigned8
	<b>Can be changed:</b> -	<b>Scaling:</b> -	<b>Dynamic index:</b> -
	<b>Unit group:</b> -	<b>Unit selection:</b> -	<b>Function diagram:</b> 2410
	<b>Min:</b> -	<b>Max:</b> -	<b>Factory setting:</b> -

**Description:** Displays PROFINET IP of Station.

## 7.4 ASCII table

### Function description

The following table contains the characters that can be used for certain parameters, e.g. serial number, password or device name on a fieldbus.

Table 7-1 Permissible characters

Character	Decimal	Hexadecimal	Meaning
	32	20	Space
!	33	21	Exclamation mark
"	34	22	Quotation mark
#	35	23	Number sign
\$	36	24	Dollar
%	37	25	Percent
&	38	26	Ampersand
'	39	27	Apostrophe, closing single quotation mark
(	40	28	Opening parenthesis
)	41	29	Closing parenthesis
*	42	2A	Asterisk
+	43	2B	Plus
,	44	2C	Comma
-	45	2D	Hyphen, minus
.	46	2E	Period, decimal point
/	47	2F	Slash, slant
0	48	30	Digit 0
...	...	...	...
9	57	39	Digit 9
:	58	3A	Colon
;	59	3B	Semicolon
<	60	3C	Less than
=	61	3D	Equals
>	62	3E	Greater than
?	63	3F	Question mark
@	64	40	Commercial At
A	65	41	Capital Letter A
...	...	...	...
Z	90	5A	Capital letter Z
[	91	5B	Opening bracket
\	92	5C	Backslash
]	93	5D	Closing bracket
^	94	5E	Circumflex
_	95	5F	Underline

7.4 ASCII table

Character	Decimal	Hexadecimal	Meaning
'	96	60	Opening single quotation mark
a	97	61	Small letter a
...	...	...	...
z	122	7A	Small Letter z
{	123	7B	Opening brace
	124	7C	Vertical line
}	125	7D	Closing brace
~	126	7E	Tilde



# Saving the settings and series commissioning

## Overview

After commissioning, your settings are saved in the converter so that they are protected against power failure.

We recommend that you additionally back up the settings on a storage medium outside the converter. Without backup, your settings could be lost if the converter develops a defect.

The following storage media are available for your settings:

- Memory card
- Operator panel
- SINAMICS G120 Smart Access

## 8.1 Memory card

### 8.1.1 Recommended memory cards

#### Function description



Table 8-1 Memory card to back up converter settings

Scope of delivery	Article number
Memory card without firmware	6SL3054-4AG00-2AA0

#### More information

##### Using memory cards from other manufacturers

If you use a different SD memory card, then you must format it as follows:

- Insert the card into your PC's card reader.
- Command to format the card:  
format x: /fs:fat or format x: /fs:fat32 (x: Drive code of the memory card on your PC.)

##### Functional restrictions with memory cards from other manufacturers

The following functions are either not possible – or only with some restrictions – when using memory cards from other manufacturers:

- Know-how protection is only possible with one of the recommended memory cards.
- In certain circumstances, memory cards from other manufacturers do not support writing or reading data from/to the converter.

### 8.1.2 Saving setting on a memory card

#### Overview

We recommend that you insert the memory card before switching on the converter. The converter always also backs up its settings on an inserted card.

If you wish to back up the converter settings on a memory card, you have two options:

#### See also

Firmware upgrade and downgrade (Page 887)

### 8.1.2.1 Automatic backup

#### Precondition

The converter power supply has been switched off.

#### Function description

##### Procedure



1. Insert an empty memory card into the converter.
2. Switch on the power supply for the converter.

After the power supply has been switched on, the converter copies its changed settings to the memory card.

□

#### Note

##### Accidental damage to the converter firmware

If the memory card contains converter firmware, the converter may perform an operating system update the next time the supply voltage is switched on. If you switch off the supply voltage during the operating system update, the converter firmware may be incompletely loaded and damaged. The converter cannot be operated with corrupt firmware.

- Before inserting the memory card, ascertain whether it also contains converter firmware.
- Do not switch off converter power supply during an operating system update.



Firmware upgrade and downgrade (Page 887)

#### Note

##### Accidental overwrite of the converter settings

When the supply voltage is switched on, the converter automatically accepts the settings already backed up on the memory card. If you use a memory card on which settings are already backed up, you will overwrite the settings of the converter.

- To automatically backup your settings, use only a memory card that does not contain any other settings.

### 8.1.2.2 Manual backup

#### Precondition

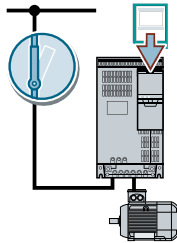

- The converter power supply has been switched on.
- No memory card is inserted in the converter.

#### Function description

##### Procedure with BOP-2

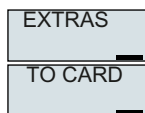

In the "OPTIONS" menu, select "TO CARD".

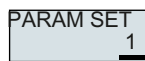

Set the number of your data backup. You can back up 99 different settings on the memory card.

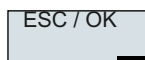

Start data transfer with OK.

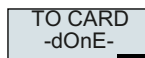
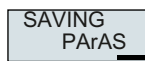

Wait until the converter has backed up the settings to the memory card.

You have backed up the settings of the converter to the memory card.



### 8.1.3 Transferring the setting from the memory card

#### 8.1.3.1 Automatic transfer

#### Precondition

The converter power supply has been switched off.

## Function description

### Procedure



1. Insert the memory card into the converter.
2. Then switch on the converter power supply.

If there is valid parameter data on the memory card, then the converter accepts the data from the memory card.

□

### 8.1.3.2 Manually transferring

#### Precondition

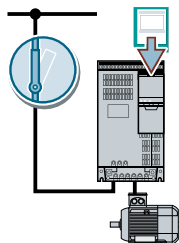

- The converter power supply has been switched on.
- No memory card is inserted in the converter.

## Function description

### Procedure with the BOP-2

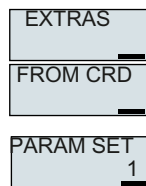

In the "OPTIONS" menu, select "FROM CRD".

Set the number of your data backup. You can back up 99 different settings on the memory card.

8.1 Memory card

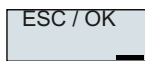

Start data transfer with OK.

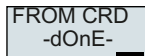

Wait until the converter has transferred the settings from the memory card.

Switch off the converter power supply.

Wait until all LEDs on the converter are dark.

Switch on the converter power supply again.

You have transferred the settings from the memory card to the converter.



8.1.4 Safely remove the memory card

<p><b>NOTICE</b></p> <p><b>Data loss from improper handling of the memory card</b></p> <p>If you remove the memory card when the converter is switched on without implementing the "safe removal" function you may destroy the file system on the memory card. The data on the memory card are lost. The memory card will only function again after formatting.</p> <ul style="list-style-type: none"> <li>• Only remove the memory card using the "safe removal" function.</li> </ul>
--

Function description

Procedure with the BOP-2

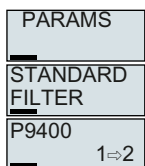

1. Set p9400 = 2.  
If a memory card is inserted, p9400 = 1.

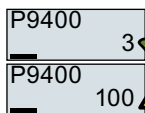

2. The converter sets p9400 = 3 or p9400 = 100.
  - p9400 = 3: You may remove the memory card from the converter.
  - p9400 = 100: You must not remove the memory card. Wait for several seconds and then set p9400 = 2 again.

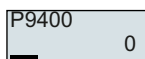

3. Remove the memory card. After removing the memory card, p9400 = 0.

You have now safely removed the memory card using BOP-2.



## 8.1.5 Message for a memory card that is not inserted

### Function description

The converter identifies that a memory card is not inserted, and signals this state. The message is deactivated in the converter factory setting.

#### Activate message

##### Procedure

1. Set  $p2118[x] = 1101$ ,  $x = 0, 1, \dots, 19$
2. Set  $p2119[x] = 2$

Message A01101 for a memory card that is not inserted is activated.

□

To cyclically signal to the higher-level control that a memory card is not inserted, connect parameter r9401 to the send data of the fieldbus interface.

#### Deactivate message

##### Procedure

1. Set  $p2118[x] = 1101$ ,  $x = 0, 1, \dots, 19$
2. Set  $p2119[x] = 3$

Message A01101 for a memory card that is not inserted is deactivated.

□

### Parameter

Parameter	Explanation	Factory setting
p2118[0 ... 19]	Change message type, message number	0
p2119[0 ... 19]	Change message type, type	0
r9401	Safely remove memory card status	-

## 8.2 Operator panel

### 8.2.1 Backup using the operator panel

#### Precondition

The converter power supply has been switched on.

#### Function description

##### Procedure

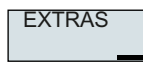

1. In the "OPTIONS" menu, select "TO BOP".

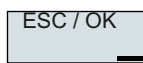
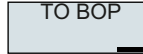

2. Start data transfer with OK.

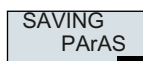

3. Wait until the converter has backed up the settings to the BOP-2.

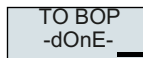
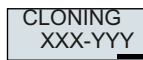
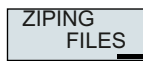

You have backed up the settings to the BOP-2.



### 8.2.2 Transfer to the converter

#### Precondition

The converter power supply has been switched on.



## Function description

### Procedure

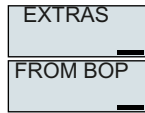

1. In the "OPTIONS" menu, select "FROM BOP".

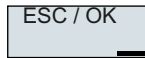

2. Start data transfer with OK.

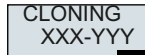

3. Wait until the converter has written the settings to the memory card.

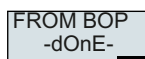
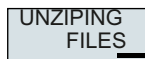

4. Switch off the converter power supply.

5. Wait until all converter LEDs are dark.

6. Switch on the converter power supply again. Your settings become active after switching on.

You have transferred the settings to the converter.



## 8.3 Other ways to back up settings

### Function description

In addition to the default setting, the converter has an internal memory for backing up three other settings.

On the memory card, you can back up 99 other settings in addition to the default setting.

 Additional information is available on the Internet: Memory options (<http://support.automation.siemens.com/WW/view/en/43512514>).

## **8.4 Series commissioning**

### **Overview**

Series commissioning is the commissioning of several identical drives.

### **Precondition**

The converter to which the settings are transferred has the same article number and the same or a higher firmware version as the source converter.

### **Function description**

#### **Procedure**

1. Commission the first converter.
2. Back up the settings of the first converter to an external storage medium.
3. Transfer the settings from the first converter to another converter via the data storage medium.

## 8.5 Write protection

### Overview

The write protection prevents unauthorized changing of the converter settings.

### Function description

Write protection is applicable for all user interfaces:

- Operator panel BOP-2 and IOP-2
- SINAMICS G120 Smart Access
- Parameter changes via fieldbus

No password is required for write protection.

### Activate and deactivate write protection

Parameter		
r7760	<b>Write protection/know-how protection status</b>	
	.00	1 signal: Write protection active
p7761	<b>Write protection</b> (factory setting: 0)	
	0:	Deactivate write protection
	1:	Activate write protection

### Parameters

Table 8-2 Parameters that can be changed with active write protection

Number	Name
p0003	Access level / Acc_level
p0010	Drive commissioning parameter filter / Drv comm par_filt
p0124[0...n]	CU detection using LED / CU detect LED
p0970	Reset drive parameters / Drive par reset
p0971	Save parameters / Sav par
p0972	Drive unit reset / Drv_unit reset
p2111	Alarm counter / Alarm counter
p3950	Service parameter / Serv par
p3981	Acknowledge drive object faults / Ackn DO faults
p3985	Master control mode selection / PcCtrl mode select
p7761	Write protection / Write protection
p8805	Identification and Maintenance 4 Configuration / I&M 4 Config
p8806[0...53]	Identification and Maintenance 1 / I&M 1
p8807[0...15]	Identification and Maintenance 2 / I&M 2
p8808[0...53]	Identification and Maintenance 3 / I&M 3
p8809[0...53]	Identification and Maintenance 4 / I&M 4

Number	Name
p9400	Safely remove memory card / Mem_card rem
p9484	BICO interconnections search signal source / BICO S_src srch

---

**Note****Write protection for multimaster fieldbus systems**

Via multimaster fieldbus systems, e.g. BACnet or Modbus RTU, in spite of write protection being activated, parameters can still be changed. So that write protection is also active when accessing via these fieldbuses, you must additionally set p7762 to 1.

---

## 8.6 Know-how protection



### Overview

Know-how protection prevents unauthorized reading of the converter settings.

To protect your converter settings against unauthorized copying, in addition to know-how protection, you can also activate copy protection.

### Precondition

Know-how protection requires a password.

Combination of know-how protection and copy protection	Is a memory card necessary?	
Know-how protection without copy protection	The converter can be operated with or without memory card.	
Know-how protection with basic copy protection Know-how protection with extended copy protection		The converter can only be operated with a SIEMENS memory card  Recommended memory cards (Page 760)

### Function description

The active know-how protection provides the following:

- With just a few exceptions, the values of all adjustable parameters p ... are invisible.
  - Several adjustable parameters can be read and changed when know-how protection is active.  
In addition, you can define an exception list of adjustable parameters, which end users may change.
  - Several adjustable parameters can be read but not changed when know-how protection is active.
- The values of monitoring parameters r ... remain visible.
- Adjustable parameters cannot be changed using commissioning tools.

- Locked functions:
  - Automatic controller optimization
  - Stationary or rotating measurement of the motor data identification
  - Deleting the alarm history and the fault history
  - Generating acceptance documents for safety functions
- Executable functions:
  - Restoring factory settings
  - Acknowledging faults
  - Displaying faults, alarms, fault history, and alarm history
  - Reading out the diagnostic buffer
  - Uploading adjustable parameters that can be changed or read when know-how protection is active.

When know-how protection is active, support can only be provided (from Technical Support) after prior agreement from the machine manufacturer (OEM).

#### Know-how protection without copy protection

You can transfer converter settings to other converters using a memory card or an Operator Panel.



#### Know-how protection with basic copy protection

After replacing a converter, to be able to operate the new converter with the settings of the replaced converter without knowing the password, the memory card must be inserted in the new converter.

#### Know-how protection with extended copy protection

It is not possible to insert and use the memory card in another converter without knowing the password.

#### Commissioning know-how protection

1. Check as to whether you must extend the exception list.
  -  List of exceptions (Page 775)
2. Activate the know-how protection.
  -  Know-how protection (Page 776)

## Parameters

Table 8-3 Parameters that can be changed with active know-how protection

Number	Name
p0003	Access level / Acc_level
p0010	Drive commissioning parameter filter / Drv comm par_filt
p0124[0...n]	CU detection using LED / CU detect LED
p0791[0...1]	CO: Fieldbus analog outputs / Fieldbus AO

8.6 Know-how protection

Number	Name
p0970	Reset drive parameters / Drive par reset
p0971	Save parameters / Sav par
p0972	Drive unit reset / Drv_unit reset
p2040	Fieldbus interface monitoring time / Fieldbus t_monit
p2111	Alarm counter / Alarm counter
p3950	Service parameter / Serv par
p3981	Acknowledge drive object faults / Ackn DO faults
p3985	Master control mode selection / PcCtrl mode select
p7761	Write protection / Write protection
p8402[0...8]	RTC daylight saving time setting / RTC DST
p8805	Identification and Maintenance 4 Configuration / I&M 4 Config
p8806[0...53]	Identification and Maintenance 1 / I&M 1
p8807[0...15]	Identification and Maintenance 2 / I&M 2
p8808[0...53]	Identification and Maintenance 3 / I&M 3
p8809[0...53]	Identification and Maintenance 4 / I&M 4
p8980	EtherNet/IP profile / Eth/IP profile
p8981	EtherNet/IP ODVA STOP mode / Eth/IP ODVA STOP
p8982	EtherNet/IP ODVA speed scaling / Eth/IP ODVA n scal
p8983	EtherNet/IP ODVA torque scaling / Eth/IP ODVA M scal
p9400	Safely remove memory card / Mem_card rem
p9484	BICO interconnections search signal source / BICO S_src srch

Table 8-4 Parameters that can be read with active know-how protection

Number	Name
p0015	Macro drive unit / Macro drv unit
p0100	IEC/NEMA Standards / IEC/NEMA Standards
p0170	Number of Command Data Sets (CDS) / CDS count
p0180	Number of Drive Data Sets (DDS) / DDS count
p0300[0...n]	Motor type selection / Mot type sel
p0304[0...n]	Rated motor voltage / Mot U_rated
p0305[0...n]	Rated motor current / Mot I_rated
p0505	Selecting the system of units / Unit sys select
p0595	Technological unit selection / Tech unit select
p0730	BI: CU signal source for terminal DO 0 / CU S_src DO 0
p0731	BI: CU signal source for terminal DO 1 / CU S_src DO 1
p0732	BI: CU signal source for terminal DO 2 / CU S_src DO 2
p0806	BI: Inhibit master control / Inhibit PcCtrl
p0870	BI: Close main contactor / Close main cont
p0922	PROFIdrive PZD telegram selection / PZD telegr_sel
p1080[0...n]	Minimum velocity / v_min
p1082[0...n]	Maximum velocity / v_max



Number	Name
p1520[0...n]	CO: Torque limit upper / M_max upper
p2000	Reference speed reference frequency / n_ref f_ref
p2001	Reference voltage / Reference voltage
p2002	Reference current / I_ref
p2003	Reference torque / M_ref
p2006	Reference temperature / Ref temp
p2030	Fieldbus interface protocol selection / Fieldbus protocol
p2038	PROFIdrive STW/ZSW interface mode / PD STW/ZSW IF mode
p2079	PROFIdrive PZD telegram selection extended / PZD telegr ext
p7763	KHP OEM exception list number of indices for p7764 / KHP OEM qty p7765
p7764[0...n]	KHP OEM exception list / KHP OEM excep list
p11026	Free tec_ctrl 0 unit selection / Ftec0 unit sel
p11126	Free tec_ctrl 1 unit selection / Ftec1 unit sel
p11226	Free tec_ctrl 2 unit selection / Ftec2 unit sel

### 8.6.1 Extending the exception list for know-how protection

In the factory setting, the exception list only includes the password for know-how protection.

Before activating know-how protection, you can additionally enter the adjustable parameters in the exception list, which must still be able to be read and changed by end users – even if know-how protection has been activated.

You do not need to change the exception list, if, with exception of the password, you do not require additional adjustable parameters in the exception list.

#### Absolute know-how protection

If you remove password p7766 from the exception list, it is no longer possible to enter or change the password for know-how protection.

You must reset the converter to the factory settings in order to be able to gain access to the converter adjustable parameters. When restoring the factory settings, you lose what you have configured in the converter, and you must recommission the converter.

#### Parameter

Parameter	Description	Factory setting
p7763	KHP OEM exception list, number of indices for p7764	1
p7764[0...p7763]	KHP OEM exception list p7766 is the password for know-how protection	[0] 7766 [1...499] 0

## 8.6.2 Activating and deactivating know-how protection

### Conditions for know-how protection

- The converter has now been commissioned.
- You have generated the exception list for know-how protection.
- To guarantee know-how protection, you must ensure that the project does not remain at the end user as a file.

### Preventing data reconstruction from the memory card

As soon as know-how protection has been activated, the converter only backs up encrypted data to the memory card.

In order to guarantee know-how protection, after activating know-how protection, we recommend that you insert a new, empty memory card. For memory cards that have already been written to, previously backed up data that was not encrypted can be reconstructed.

### Parameter

Parameter	Description	Factory setting
r7758[0...19]	KHP Control Unit serial number	---
p7759[0...19]	KHP Control Unit reference serial number	---
r7760	Write protection/know-how protection status	---
p7765	KHP configuration	0000 bin
p7766[0...29]	KHP password, input	---
p7767[0...29]	KHP password, new	---
p7768[0...29]	KHP password, confirmation	---
p7769[0...20]	KHP memory card reference serial number	---
r7843[0...20]	Memory card serial number	---





## Warnings, faults and system messages

The converter has the following diagnostic types:

- LED  
The LEDs at the front of the converter immediately inform you about the most important converter states.
- Alarms and faults  
Every alarm and every fault has a unique number.  
The converter signals alarms and faults via the following interfaces:
  - Fieldbus
  - Terminal strip with the appropriate setting
  - Interface to the BOP-2 or IOP-2 operator panel
  - Interface to SINAMICS G120 Smart Access
- Identification & maintenance data (I&M)  
If requested, the converter sends data to the higher-level control via PROFINET:
  - Converter-specific data
  - Plant-specific data

## 9.1 Operating states indicated on LEDs

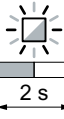
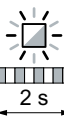
Table 9-1 Explanation of symbols for the following tables

	LED is ON
	LED is OFF
	LED flashes slowly
	LED flashes quickly
	LED flashes with variable frequency

Please contact Technical Support for LED states that are not described in the following.

Table 9-2 Basic states







RDY	Explanation
	Temporary state after the supply voltage is switched on.
	The converter is free of faults
	Commissioning or reset to factory settings
	A fault is active
	Firmware update is active
	Converter waits until the power supply is switched off and switched on again after a firmware update

Table 9-3 PROFINET fieldbus











LNK	Explanation
	Communication via PROFINET is error-free
	Device naming is active
	No communication via PROFINET









Table 9-4 Fieldbuses via RS 485 interface

BF	Explanation
	Data exchange between the converter and control system is active
	The fieldbus is active, however, the converter is not receiving any process data
	When LED RDY flashes simultaneously: Converter waits until the power supply is switched off and switched on again after a firmware update
	No fieldbus connection is available
	When LED RDY flashes simultaneously: Incorrect memory card
	Firmware update failed
	Firmware update is active

**Communication via Modbus or USS:**

If the fieldbus monitoring is deactivated with p2040 = 0, the BF-LED remains dark, independent of the communication state.

Table 9-5 PROFINET fieldbus

BF	Explanation
	Data exchange between the converter and control system is active
	Fieldbus interface is not being used
	The fieldbus is improperly configured.
	In conjunction with a synchronously flashing LED RDY: Converter waits until the power supply is switched off and switched on again after a firmware update
	No communication with higher-level controller
	In conjunction with an asynchronously flashing LED RDY: Incorrect memory card
	Firmware update failed
	Firmware update is active

## 9.2 System runtime

### Overview

By evaluating the system runtime of the converter, you can decide when you should replace components subject to wear in time before they fail - such as fans, motors and gear units.

### Function description

The system runtime is started as soon as the Control Unit power supply is switched-on. The system runtime stops when the Control Unit is switched off.

The system runtime comprises r2114[0] (milliseconds) and r2114[1] (days):

System runtime = r2114[1] × days + r2114[0] × milliseconds

If r2114[0] has reached a value of 86,400,000 ms (24 hours), r2114[0] is set to the value 0 and the value of r2114[1] is increased by 1.

### Example

Parameter	Description
r2114[0]	System runtime (ms)
r2114[1]	System runtime (days)

You cannot reset the system runtime.

### Parameters

Parameter	Description	Factory setting
r2114[0 ... 1]	Total system runtime	-

## 9.3 Identification & maintenance data (I&M)

### I&M data

The converter supports the following identification and maintenance (I&M) data.

I&M data	Format	Explanation	Associated parameters	Example for the content
I&M0	u8[64] PROFIBUS u8[54] PROFINET	Converter-specific data, read only	-	See below
I&M1	Visible String [32]	Plant/system identifier	p8806[0 ... 31]	"ak12- ne.bo2=fu1"
	Visible String [22]	Location code	p8806[32 ... 53]	"sc2+or45"
I&M2	Visible String [16]	Date	p8807[0 ... 15]	"2013-01-21 16:15"
I&M3	Visible String [54]	Any comment	p8808[0 ... 53]	-
I&M4	Octet String[54]	Check signature to track changes for Safety Integrated. This value can be changed by the user. The test signature is reset to the value generated by the machine if p8805 = 0 is used.	p8809[0 ... 53]	Values of r9781[0] and r9782[0]

When requested, the converter transfers its I&M data to a higher-level control or to a PC/PG with installed STEP 7 or TIA Portal.

### I&M0

Designation	Format	Example for the content	Valid for PRO-FINET	Valid for PRO-FIBUS
Manufacturer-specific	u8[10]	00 ... 00 hex	---	✓
MANUFACTURER_ID	u16	42d hex (=Siemens)	✓	✓
ORDER_ID	Visible String [20]	„6SL3246-0BA22-1FA0“	✓	✓
SERIAL_NUMBER	Visible String [16]	„T-R32015957“	✓	✓
HARDWARE_REVISION	u16	0001 hex	✓	✓
SOFTWARE_REVISION	char, u8[3]	„V“ 04.70.19	✓	✓
REVISION_COUNTER	u16	0000 hex	✓	✓
PROFILE_ID	u16	3A00 hex	✓	✓
PROFILE_SPECIFIC_TYPE	u16	0000 hex	✓	✓
IM_VERSION	u8[2]	01.02	✓	✓
IM_SUPPORTED	bit[16]	001E hex	✓	✓

## 9.4 Alarms, alarm buffer, and alarm history

### Overview

An alarm generally indicates that the converter may no longer be able to maintain the operation of the motor in future.

The extended diagnostics have an alarm buffer and an alarm history, in which the converter stores the most recent alarms.

### Function description

Alarms have the following properties:

- Incoming alarms have no direct influence on the converter.
- A warning disappears as soon as its cause is eliminated.
- Alarms do not have to be acknowledged.
- Alarms are displayed as follows:
  - Display via the fieldbus
  - Display on the operator panel with Axxxxx
  - Display via SINAMICS G120 Smart Access

Alarm code or alarm value describe the cause of the alarm.

### Alarm buffer

Alarm code		Alarm value		Alarm time received		Alarm time removed		
		I32	float	Days	ms			
r2122[0]	r2124[0]	r2134[0]		r2145[0]	r2123[0]	old	r2146[0]	r2125[0]
[1]	[1]	[1]		[1]	[1]	↓ new	[1]	[1]
[2]	[2]	[2]		[2]	[2]		[2]	[2]
[3]	[3]	[3]		[3]	[3]		[3]	[3]
[4]	[4]	[4]		[4]	[4]		[4]	[4]
[5]	[5]	[5]		[5]	[5]		[5]	[5]
[6]	[6]	[6]		[6]	[6]		[6]	[6]
[7]	[7]	[7]		[7]	[7]		[7]	[7]

Figure 9-1 Alarm buffer

The converter saves incoming alarms in the alarm buffer. An alarm includes an alarm code, an alarm value, and two alarm times:

- Alarm code: r2122
- Alarm value: r2124 in fixed-point format "I32", r2134 in floating-point format "Float"
- Alarm time received = r2145 + r2123
- Alarm time removed = r2146 + r2125

The converter takes its internal time calculation to save the alarm times.

 System runtime (Page 780)

Up to 8 alarms can be saved in the alarm buffer.



In the alarm buffer, the alarms are sorted according to "Alarm time received". If the alarm buffer is completely filled and an additional alarm occurs, then the converter overwrites the values with Index [7].

### Alarm history

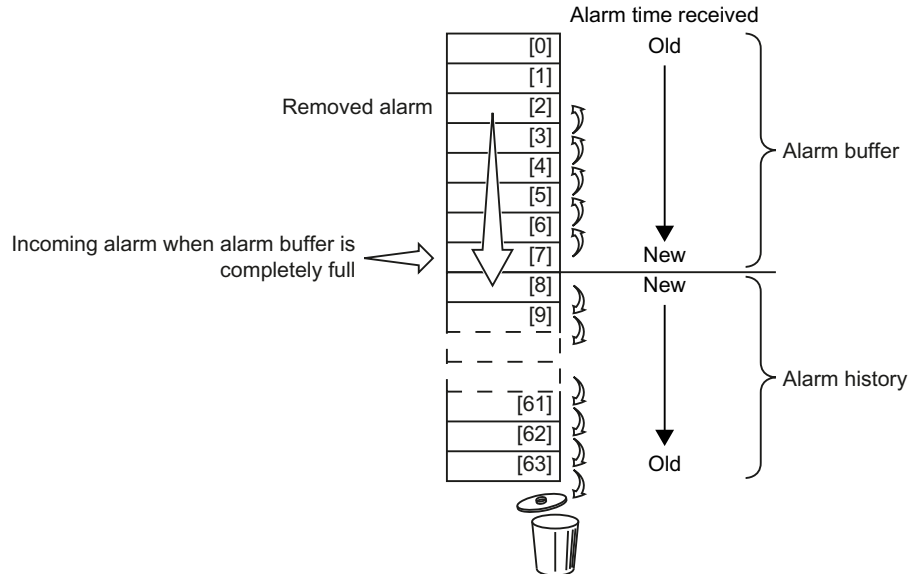

Figure 9-2 Shifting removed alarms into the alarm history

If the alarm buffer is completely filled and an additional alarm occurs, the converter shifts all removed alarms into the alarm history. The following occurs in detail:

1. To create space after position [8] in the alarm history, the converter shifts the alarms already stored in the alarm history "down" by one or more positions.  
 If the alarm history is completely full, the converter will delete the oldest alarms.
2. The converter moves the removed alarms from the alarm buffer to the now freed up positions of the alarm history.  
 Alarms that have not been removed remain in the alarm buffer.
3. The converter closes gaps in the alarm buffer that occurred when the removed alarms were shifted in the alarm history by shifting the alarms that have not been removed "up".
4. The converter saves the received alarm as the latest alarm in the alarm buffer.

The alarm history saves up to 56 alarms.

In the alarm history, alarms are sorted according to the "alarm time received". The latest alarm has Index [8].

## Parameters

Table 9-6 Parameters of the alarm buffer and the alarm history

Parameter	Description	Factory setting
p2111	Alarm counter	0
r2122[0 ... 63]	Alarm code	-

9.4 Alarms, alarm buffer, and alarm history

Parameter	Description	Factory setting
r2123[0 ... 63]	Alarm time received in milliseconds	- ms
r2124[0 ... 63]	Alarm value	-
r2125[0 ... 63]	Alarm time removed in milliseconds	- ms
r2132	CO: Actual alarm code	-
r2134[0 ... 63]	Alarm value for float values	-
r2145[0 ... 63]	Alarm time received in days	-
r2146[0 ... 63]	Alarm time removed in days	-

Table 9-7 Extended settings for alarms

Parameter	Description	Factory setting
You can change up to 20 different alarms into a fault or suppress alarms:		
p2118[0 ... 19]	Change message type, message number	0
p2119[0 ... 19]	Change message type, type	1

Further information is provided in the parameter list.

## 9.5 Faults, alarm buffer and alarm history

### Overview

A fault generally indicates that the converter can no longer maintain the operation of the motor. The extended diagnostics have a fault buffer and a fault history, in which the converter stores the most recent faults.

### Function description

Faults have the following properties:

- In general, a fault leads to the motor being switched off.
- A fault must be acknowledged.
- Faults are displayed as follows:
  - Display via the fieldbus
  - Display on the operator panel with Fxxxxx
  - Display on the converter via the LED RDY
  - Display via SINAMICS G120 Smart Access

### Fault buffer

Fault code	Fault value		Fault time received		Old	Fault time removed	
	I32	float	Days	ms		Days	ms
r0945[0]	r0949[0]	r2133[0]	r2130[0]	r0948[0]	↓ New	r2136[0]	r2109[0]
[1]	[1]	[1]	[1]	[1]		[1]	[1]
[2]	[2]	[2]	[2]	[2]		[2]	[2]
[3]	[3]	[3]	[3]	[3]		[3]	[3]
[4]	[4]	[4]	[4]	[4]		[4]	[4]
[5]	[5]	[5]	[5]	[5]		[5]	[5]
[6]	[6]	[6]	[6]	[6]		[6]	[6]
[7]	[7]	[7]	[7]	[7]		[7]	[7]

Figure 9-3 Fault buffer

The converter saves incoming faults in the fault buffer. A fault includes a fault code, a fault value, and two fault times:

- Fault code: r0945  
The fault code and fault value describe the cause of the fault.
- Fault value: r0949 in fixed-point format "I32", r2133 in floating-point format "Float"
- Fault time received = r2130 + r0948
- Fault time removed = r2136 + r2109

The converter takes its internal time calculation to save the fault times.

 System runtime (Page 780)

Up to 8 faults can be saved in the fault buffer.

In the fault buffer, the faults are sorted according to "Fault time received". If the fault buffer is completely filled and an additional fault occurs, then the converter overwrites the values with Index [7].

### Acknowledging a fault

To acknowledge a fault, you have the following options:

- Acknowledge via the fieldbus
- Acknowledge via a digital input
- Acknowledge via the operator panel
- Switch off the converter power supply and switch on again

Faults detected during the converter-internal monitoring of hardware and firmware can be acknowledged only by switching the supply voltage off and on again. The list of fault codes and alarm codes includes the note on the limitations on the acknowledgment for the corresponding fault codes.

### Fault history

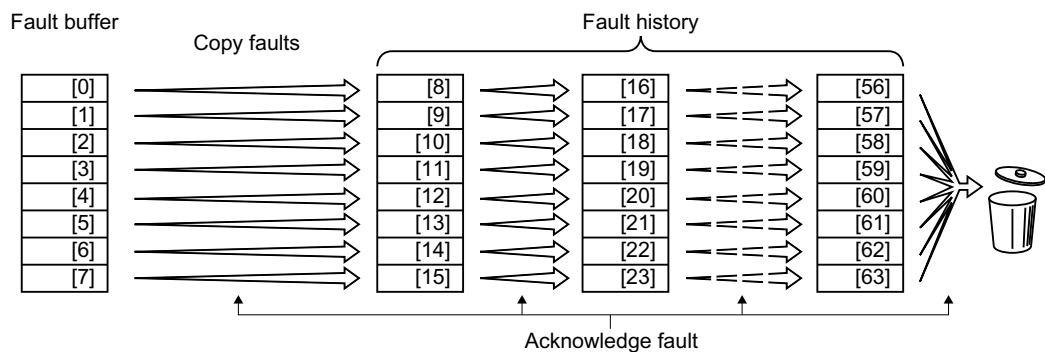

Figure 9-4 Fault history after acknowledging the faults

If at least one of the fault causes in the fault buffer has been removed and you acknowledge the faults, the following takes place:

1. The converter shifts the values previously saved in the fault history by eight indexes. The converter deletes the faults that were saved in the indexes [56 ... 63] before the acknowledgement.
2. The converter copies the contents of the fault buffer to the memory locations [8 ... 15] in the fault history.
3. The converter deletes the faults that have been removed from the fault buffer. The faults that have not been removed are now saved both in the fault buffer and in the fault history.
4. The converter writes the time of acknowledgement of the removed faults to "Fault time removed". The "Fault time removed" of the faults that have not been removed retains the value = 0.

The fault history can contain up to 56 faults.

### Deleting the fault history

To delete all faults from the fault history, set parameter p0952 = 0.

## Parameters

Table 9-8 Parameters of the fault buffer and the fault history

Parameter	Description	Factory setting
r0945[0 ... 63]	Fault code	-
r0948[0 ... 63]	Fault time received in milliseconds	- ms
r0949[0 ... 63]	Fault value	-
p0952	Fault cases counter	0
r2109[0 ... 63]	Fault time removed in milliseconds	- ms
r2130[0 ... 63]	Fault time received in days	-
r2131	CO: Actual fault code	-
r2133[0 ... 63]	Fault value for float values	-
r2136[0 ... 63]	Fault time removed in days	-

### Extended settings for faults

Parameter	Description	Factory setting
p2100[0...19]	Changing the fault reaction, fault number	0
p2101[0...19]	Changing the fault reaction, reaction	0
p2118[0 ... 19]	Change message type, message number	0
p2119[0 ... 19]	Change message type, type	1
p2126[0 ... 19]	Changing the acknowledge mode, fault number	0
p2127[0 ... 19]	Changing the acknowledge mode	1

Further information is provided in the parameter list.

## 9.6 List of fault codes and alarm codes

### 9.6.1 Overview of faults and alarms

#### Overview

A message comprises a letter followed by the relevant number.

The letters have the following meaning:

<b>A</b> . . . .	Alarm code . . . .
<b>F</b> . . . .	Fault code . . . .
<b>N</b> . . . .	No report or internal message

### 9.6.2 Fault codes and alarm codes

All objects: CUG120X\_PN

---

#### **F01000 Internal software error**

**Reaction:** OFF2

**Acknowledge:** POWER ON

**Cause:** An internal software error has occurred.  
Fault value (r0949, interpret hexadecimal):  
Only for internal Siemens troubleshooting.

**Remedy:**

- evaluate fault buffer (r0945).
- carry out a POWER ON (switch-off/switch-on) for all components.
- if required, check the data on the non-volatile memory (e.g. memory card).
- upgrade firmware to later version.
- contact Technical Support.
- replace the Control Unit.

---

#### **F01001 FloatingPoint exception**

**Reaction:** OFF2

**Acknowledge:** POWER ON

---

<b>Cause:</b>	<p>An exception occurred during an operation with the FloatingPoint data type.</p> <p>The error may be caused by the basic system or an OA application (e.g. FBLOCKS, DCC).</p> <p>Fault value (r0949, interpret hexadecimal):</p> <p>Only for internal Siemens troubleshooting.</p> <p>Note:</p> <p>Refer to r9999 for further information about this fault.</p> <p>r9999[0]: Fault number.</p> <p>r9999[1]: Program counter at the time when the exception occurred.</p> <p>r9999[2]: Cause of the FloatingPoint exception.</p> <p>Bit 0 = 1: Operation invalid</p> <p>Bit 1 = 1: Division by zero</p> <p>Bit 2 = 1: Overflow</p> <p>Bit 3 = 1: Underflow</p> <p>Bit 4 = 1: Inaccurate result</p>
<b>Remedy:</b>	<ul style="list-style-type: none"> <li>- carry out a POWER ON (switch-off/switch-on) for all components.</li> <li>- check configuration and signals of the blocks in FBLOCKS.</li> <li>- check configuration and signals of DCC charts.</li> <li>- upgrade firmware to later version.</li> <li>- contact Technical Support.</li> </ul>

---

**F01002 Internal software error**

<b>Reaction:</b>	OFF2
<b>Acknowledge:</b>	IMMEDIATELY
<b>Cause:</b>	<p>An internal software error has occurred.</p> <p>Fault value (r0949, interpret hexadecimal):</p> <p>Only for internal Siemens troubleshooting.</p>
<b>Remedy:</b>	<ul style="list-style-type: none"> <li>- carry out a POWER ON (switch-off/switch-on) for all components.</li> <li>- upgrade firmware to later version.</li> <li>- contact Technical Support.</li> </ul>

---

**F01003 Acknowledgment delay when accessing the memory**

<b>Reaction:</b>	OFF2
<b>Acknowledge:</b>	IMMEDIATELY
<b>Cause:</b>	<p>A memory area was accessed that does not return a "READY".</p> <p>Fault value (r0949, interpret hexadecimal):</p> <p>Only for internal Siemens troubleshooting.</p>
<b>Remedy:</b>	<ul style="list-style-type: none"> <li>- carry out a POWER ON (switch-off/switch-on) for all components.</li> <li>- contact Technical Support.</li> </ul>

---

**N01004 (F, A) Internal software error**

<b>Reaction:</b>	NONE
<b>Acknowledge:</b>	NONE
<b>Cause:</b>	<p>An internal software error has occurred.</p> <p>Fault value (r0949, hexadecimal):</p> <p>Only for internal Siemens troubleshooting.</p>
<b>Remedy:</b>	<ul style="list-style-type: none"> <li>- read out diagnostics parameter (r9999).</li> <li>- contact Technical Support.</li> </ul> <p>See also: r9999 (Software error internal supplementary diagnostics)</p>

---

**F01005**      **File upload/download error**

**Reaction:**      NONE

**Acknowledge:**    IMMEDIATELY

**Cause:**          The upload or download of EEPROM data was unsuccessful.  
Fault value (r0949, interpret hexadecimal):  
yyxxxx hex: yy = component number, xxxx = fault cause  
xxxx = 000B hex = 11 dec:  
Power unit component has detected a checksum error.  
xxxx = 000F hex = 15 dec:  
The selected power unit will not accept the content of the EEPROM file.  
xxxx = 0011 hex = 17 dec:  
Power unit component has detected an internal access error.  
xxxx = 0012 hex = 18 dec:  
After several communication attempts, no response from the power unit component.  
xxxx = 008B hex = 140 dec:  
EEPROM file for the power unit component not available on the memory card.  
xxxx = 008D hex = 141 dec:  
An inconsistent length of the firmware file was signaled. It is possible that the download/upload has been interrupted.  
xxxx = 0090 hex = 144 dec:  
When checking the file that was loaded, the component detected a fault (checksum). It is possible that the file on the memory card is defective.  
xxxx = 0092 hex = 146 dec:  
This SW or HW does not support the selected function.  
xxxx = 009C hex = 156 dec:  
Component with the specified component number is not available (p7828).  
xxxx = Additional values:  
Only for internal Siemens troubleshooting.

**Remedy:**          Save a suitable firmware file or EEPROM file for upload or download in folder "/ee\_sac/" on the memory card.

---

**A01009 (N)**    **CU: Control module overtemperature**

**Reaction:**      NONE

**Acknowledge:**    NONE

**Cause:**          The temperature (r0037[0]) of the control module (Control Unit) has exceeded the specified limit value.

**Remedy:**          - check the air intake for the Control Unit.  
- check the Control Unit fan.

**Note:**  
The alarm is automatically withdrawn once the limit value has been fallen below.

---

**F01010**      **Drive type unknown**

**Reaction:**      NONE

**Acknowledge:**    IMMEDIATELY

**Cause:**          An unknown drive type was found.

**Remedy:**          - replace Power Module.  
- carry out a POWER ON (switch-off/switch-on).  
- upgrade firmware to later version.  
- contact Technical Support.

---

**F01015**      **Internal software error**

**Reaction:**      OFF2

**Acknowledge:**    POWER ON



- Cause:** An internal software error has occurred.  
Fault value (r0949, interpret decimal):  
Only for internal Siemens troubleshooting.
- Remedy:** - carry out a POWER ON (switch-off/switch-on) for all components.  
- upgrade firmware to later version.  
- contact Technical Support.

---

**A01016 (F) Firmware changed****Reaction:** NONE**Acknowledge:** NONE

**Cause:** At least one firmware file in the directory was illegally changed on the non-volatile memory (memory card/device memory) with respect to the version when shipped from the factory.  
Alarm value (r2124, interpret decimal):  
0: Checksum of one file is incorrect.  
1: File missing.  
2: Too many files.  
3: Incorrect firmware version.  
4: Incorrect checksum of the back-up file.

**Remedy:** For the non-volatile memory for the firmware (memory card/device memory), restore the delivery condition.  
Note:  
The file involved can be read out using parameter r9925.  
The status of the firmware check is displayed using r9926.  
See also: r9925 (Firmware file incorrect), r9926 (Firmware check status)

---

**A01017 Component lists changed****Reaction:** NONE**Acknowledge:** NONE

**Cause:** On the memory card, one file in the directory /SIEMENS/SINAMICS/DATA or /ADDON/SINAMICS/DATA has been illegally changed with respect to that supplied from the factory. No changes are permitted in this directory.  
Alarm value (r2124, interpret decimal):  
zyx dec: x = Problem, y = Directory, z = File name  
x = 1: File does not exist.  
x = 2: Firmware version of the file does not match the software version.  
x = 3: File checksum is incorrect.  
y = 0: Directory /SIEMENS/SINAMICS/DATA/  
y = 1: Directory /ADDON/SINAMICS/DATA/  
z = 0: File MOTARM.ACX  
z = 1: File MOTSRM.ACX  
z = 2: File MOTSLM.ACX  
z = 3: File ENCDATA.ACX  
z = 4: File FILTDATA.ACX  
z = 5: File BRKDATA.ACX  
z = 6: File DAT\_BEAR.ACX  
z = 7: File CFG\_BEAR.ACX

**Remedy:** For the file on the memory card involved, restore the status originally supplied from the factory.

---

**F01018 Booting has been interrupted several times****Reaction:** NONE**Acknowledge:** POWER ON

9.6 List of fault codes and alarm codes

---

**Cause:** Module booting was interrupted several times. As a consequence, the module boots with the factory setting.  
Possible reasons for booting being interrupted:

- power supply interrupted.
- CPU crashed.
- parameterization invalid.

**Remedy:**

- carry out a POWER ON (switch-off/switch-on). After switching on, the module reboots from the valid parameterization (if available).
- restore the valid parameterization.

Examples:

- Carry out a first commissioning, save, carry out a POWER ON (switch-off/switch-on).
- Load another valid parameter backup (e.g. from the memory card), save, carry out a POWER ON (switch-off/switch-on).

Note:

If the fault situation is repeated, then this fault is again output after several interrupted boots.

---

**A01019 Writing to the removable data medium unsuccessful**

**Reaction:** NONE  
**Acknowledge:** NONE  
**Cause:** The write access to the removable data medium was unsuccessful.  
**Remedy:** Remove and check the removable data medium. Then run the data backup again.

---

**A01020 Writing to RAM disk unsuccessful**

**Reaction:** NONE  
**Acknowledge:** NONE  
**Cause:** A write access to the internal RAM disk was unsuccessful.  
**Remedy:** Adapt the file size for the system logbook to the internal RAM disk (p9930).  
See also: p9930 (System logbook activation)

---

**A01021 Removable data medium as USB data storage medium from the PC used**

**Reaction:** NONE  
**Acknowledge:** NONE  
**Cause:** The removable data medium is used as USB data storage medium from a PC  
As a consequence, the drive cannot access the removable data medium. When backing up, the configuration data cannot be saved on the removable data medium.  
Alarm value (r2124, interpret decimal):  
1: The know-how protection as well as the copy protection for the removable data medium is active. Backup is inhibited.  
2: The configuration data are only backed up in the Control Unit.  
See also: r7760 (Write protection/know-how protection status), r9401 (Safely remove memory card status)

**Remedy:** Deactivate the USB connection to the PC and back up the configuration data.  
Note:  
The alarm is automatically canceled when disconnecting the USB connection or when removing the removable data medium.  
See also: r9401 (Safely remove memory card status)

---

**F01023 Software timeout (internal)**

**Reaction:** NONE  
**Acknowledge:** IMMEDIATELY  
**Cause:** An internal software timeout has occurred.  
Fault value (r0949, interpret decimal):  
Only for internal Siemens troubleshooting.

**Remedy:**

- carry out a POWER ON (switch-off/switch-on) for all components.
- upgrade firmware to later version.
- contact Technical Support.

---

**A01028 (F) Configuration error**

**Reaction:** NONE

**Acknowledge:** NONE

**Cause:** The parameterization that was downloaded was generated with a different module type (Order No., MLFB).

**Remedy:** Save parameters in a non-volatile fashion (p0971 = 1).

---

**F01030 Sign-of-life failure for master control**

**Reaction:** OFF3 (IASC/DCBRK, NONE, OFF1, OFF2, STOP2)

**Acknowledge:** IMMEDIATELY

**Cause:** For active PC master control, no sign-of-life was received within the monitoring time.

The master control was returned to the active BICO interconnection.

**Remedy:** Set the monitoring time higher at the PC or, if required, completely disable the monitoring function.

For the commissioning software, the monitoring time is set as follows:

<Drive> -> Commissioning -> Control panel -> Button "Fetch master control" -> A window is displayed to set the monitoring time in milliseconds.

Notice:

The monitoring time should be set as short as possible. A long monitoring time means a late response when the communication fails!

---

**F01033 Units changeover: Reference parameter value invalid**

**Reaction:** NONE

**Acknowledge:** IMMEDIATELY

**Cause:** When changing over the units to the referred representation type, it is not permissible for any of the required reference parameters to be equal to 0.0

Fault value (r0949, parameter):

Reference parameter whose value is 0.0.

See also: p0505 (Selecting the system of units), p0595 (Technological unit selection)

**Remedy:** Set the value of the reference parameter to a number different than 0.0.

See also: p0304, p0305, p0310, p0596, p2000, p2001, p2002, p2003, r2004

---

**F01034 Units changeover: Calculation parameter values after reference value change unsuccessful**

**Reaction:** NONE

**Acknowledge:** IMMEDIATELY

**Cause:** The change of a reference parameter meant that for an involved parameter the selected value was not able to be re-calculated in the per unit representation. The change was rejected and the original parameter value restored.

Fault value (r0949, parameter):

Parameter whose value was not able to be re-calculated.

See also: p0304, p0305, p0310, p0596, p2000, p2001, p2002, p2003, r2004

**Remedy:**

- Select the value of the reference parameter such that the parameter involved can be calculated in the per unit representation.

- Technology unit selection (p0595) before changing the reference parameter p0596, set p0595 = 1.

---

**A01035 (F) ACX: Parameter back-up file corrupted**

**Reaction:** NONE

**Acknowledge:** NONE

9.6 List of fault codes and alarm codes

---

**Cause:** When the Control Unit is booted, no complete data set was found from the parameter back-up files. The last time that the parameterization was saved, it was not completely carried out.  
It is possible that the backup was interrupted by switching off or withdrawing the memory card.  
Alarm value (r2124, interpret hexadecimal):  
ddccbbaa hex:  
aa = 01 hex:  
Power up was realized without data backup. The drive is in the factory setting.  
aa = 02 hex:  
The last available internal backup data record was loaded. The parameterization must be checked. It is recommended that the parameterization is downloaded again.  
aa = 03 hex:  
The last available data record from the memory card was loaded. The parameterization must be checked.  
aa = 04 hex:  
An invalid data backup was loaded from the memory card into the drive. The drive is in the factory setting.  
dd, cc, bb:  
Only for internal Siemens troubleshooting.  
See also: p0971 (Save parameters)

**Remedy:** - Download the project again with the commissioning software.  
- save all parameters (p0971 = 1 or "copy RAM to ROM").  
See also: p0971 (Save parameters)

---

**F01036 (A) ACX: Parameter back-up file missing**

**Reaction:** NONE (OFF1, OFF2, OFF3)

**Acknowledge:** IMMEDIATELY

**Cause:** When downloading the device parameterization, a parameter back-up file PSxxxxyy.ACX associated with a drive object cannot be found.  
Fault value (r0949, interpret hexadecimal):  
Byte 1: yyy in the file name PSxxxxyy.ACX  
yyy = 000 --> consistency back-up file  
yyy = 001 ... 062 --> drive object number  
yyy = 099 --> PROFIBUS parameter back-up file  
Byte 2, 3, 4:  
Only for internal Siemens troubleshooting.

**Remedy:** If you have saved the project data using the commissioning software, carry out a new download for your project.  
Save using the function "Copy RAM to ROM" or with p0971 = 1.  
This means that the parameter files are again completely written into the non-volatile memory.  
**Note:**  
If the project data have not been backed up, then a new first commissioning is required.

---

**F01038 (A) ACX: Loading the parameter back-up file unsuccessful**

**Reaction:** NONE (OFF1, OFF2, OFF3)

**Acknowledge:** IMMEDIATELY

<b>Cause:</b>	<p>An error has occurred when downloading PSxxxxxyy.ACX or PTxxxxxyy.ACX files from the non-volatile memory.</p> <p>Fault value (r0949, interpret hexadecimal):</p> <p>Byte 1: yyy in the file name PSxxxxxyy.ACX</p> <p>yyy = 000 --&gt; consistency back-up file</p> <p>yyy = 001 ... 062 --&gt; drive object number</p> <p>yyy = 099 --&gt; PROFIBUS parameter back-up file</p> <p>Byte 2:</p> <p>255: Incorrect drive object type.</p> <p>254: Topology comparison unsuccessful -&gt; drive object type was not able to be identified.</p> <p>Reasons could be:</p> <ul style="list-style-type: none"> <li>- incorrect component type in the actual topology</li> <li>- Component does not exist in the actual topology.</li> <li>- Component not active.</li> </ul> <p>Additional values:</p> <p>Only for internal Siemens troubleshooting.</p> <p>Byte 4, 3:</p> <p>Only for internal Siemens troubleshooting.</p>
<b>Remedy:</b>	<ul style="list-style-type: none"> <li>- if you have saved the project data using the commissioning software, download the project again. Save using the function "Copy RAM to ROM" or with p0971 = 1. This means that the parameter files are again completely written to the non-volatile memory.</li> <li>- replace the memory card or Control Unit.</li> </ul>

---

<b>F01039 (A)</b>	<b>ACX: Writing to the parameter back-up file was unsuccessful</b>
<b>Reaction:</b>	NONE (OFF1, OFF2, OFF3)
<b>Acknowledge:</b>	IMMEDIATELY
<b>Cause:</b>	<p>Writing to at least one parameter back-up file PSxxxxyy.** in the non-volatile memory was unsuccessful.</p> <ul style="list-style-type: none"> <li>- in the directory /USER/SINAMICS/DATA/ at least one parameter back-up file PSxxxxyy.** has the "read only" file attribute and cannot be overwritten.</li> <li>- there is not sufficient free memory space available.</li> <li>- the non-volatile memory is defective and cannot be written to.</li> </ul> <p>Fault value (r0949, interpret hexadecimal):</p> <p>dcba hex</p> <p>a = yyy in the file names PSxxxxyy.**</p> <p>a = 000 --&gt; consistency back-up file</p> <p>a = 001 ... 062 --&gt; drive object number</p> <p>a = 099 --&gt; PROFIBUS parameter back-up file</p> <p>b = xxx in the file names PSxxxxyy.**</p> <p>b = 000 --&gt; data save started with p0971 = 1</p> <p>b = 010 --&gt; data save started with p0971 = 10</p> <p>b = 011 --&gt; data save started with p0971 = 11</p> <p>b = 012 --&gt; data save started with p0971 = 12</p> <p>d, c:</p> <p>Only for internal Siemens troubleshooting.</p>
<b>Remedy:</b>	<ul style="list-style-type: none"> <li>- check the file attribute of the files (PSxxxxyy.**, CAxxxxyy.**, CCxxxxyy.***) and, if required, change from "read only" to "writeable".</li> <li>- check the free memory space in the non-volatile memory. Approx. 80 kbyte of free memory space is required for every drive object in the system.</li> <li>- replace the memory card or Control Unit.</li> </ul>

---

**F01040 Save parameter settings and carry out a POWER ON**

<b>Reaction:</b>	OFF2
<b>Acknowledge:</b>	POWER ON

9.6 List of fault codes and alarm codes

**Cause:** A parameter has been changed that requires the parameters to be backed up and the Control Unit to be switched OFF and ON again.

**Remedy:**

- Save parameters (p0971).
- carry out a POWER ON (switch-off/switch-on) for the Control Unit.

---

**F01042 Parameter error during project download**

**Reaction:** OFF2 (NONE, OFF1, OFF3)

**Acknowledge:** IMMEDIATELY

**Cause:** An error was detected when downloading a project using the commissioning software (e.g. incorrect parameter value). For the specified parameter, it was detected that dynamic limits were exceeded that may possibly depend on other parameters.

Fault value (r0949, interpret hexadecimal):

ccbbaaaa hex

aaaa = Parameter

bb = Index

cc = fault cause

0: Parameter number illegal.

1: Parameter value cannot be changed.

2: Lower or upper value limit exceeded.

3: Sub-index incorrect.

4: No array, no sub-index.

5: Data type incorrect.

6: Setting not permitted (only resetting).

7: Descriptive element cannot be changed.

9: Descriptive data not available.

11: No master control.

15: No text array available.

17: Task cannot be executed due to operating state.

20: Illegal value.

21: Response too long.

22: Parameter address illegal.

23: Format illegal.

24: Number of values not consistent.

108: Unit unknown.

Additional values:

Only for internal Siemens troubleshooting.

**Remedy:**

- enter the correct value in the specified parameter.
- identify the parameter that restricts the limits of the specified parameter.

---

**F01043 Fatal error at project download**

**Reaction:** OFF2 (OFF1, OFF3)

**Acknowledge:** IMMEDIATELY

<b>Cause:</b>	<p>A fatal error was detected when downloading a project using the commissioning software.</p> <p>Fault value (r0949, interpret decimal):</p> <p>1: Device status cannot be changed to Device Download (drive object ON?).</p> <p>2: Incorrect drive object number.</p> <p>8: Maximum number of drive objects that can be generated exceeded.</p> <p>11: Error while generating a drive object (global component).</p> <p>12: Error while generating a drive object (drive component).</p> <p>13: Unknown drive object type.</p> <p>14: Drive status cannot be changed to "ready for operation" (r0947 and r0949).</p> <p>15: Drive status cannot be changed to drive download.</p> <p>16: Device status cannot be changed to "ready for operation".</p> <p>18: A new download is only possible if the factory settings are restored for the drive unit.</p> <p>20: The configuration is inconsistent.</p> <p>21: Error when accepting the download parameters.</p> <p>22: SW-internal download error.</p> <p>100: The download was canceled, because no write requests were received from the commissioning client (e.g. for communication error).</p> <p>Additional values:</p> <p>Only for internal Siemens troubleshooting.</p>
<b>Remedy:</b>	<ul style="list-style-type: none"> <li>- use the current version of the commissioning software.</li> <li>- modify the offline project and download again (e.g. compare the motor and Power Module in the offline project and on the drive).</li> <li>- change the drive state (is a drive rotating or is there a message/signal?).</li> <li>- carefully note any other messages/signals and remove their cause.</li> <li>- boot from previously saved files (switch-off/switch-on or p0970).</li> </ul>

---

**F01044 CU: Descriptive data error**

<b>Reaction:</b>	OFF2
<b>Acknowledge:</b>	POWER ON
<b>Cause:</b>	An error was detected when loading the descriptive data saved in the non-volatile memory.
<b>Remedy:</b>	Replace the memory card or Control Unit.

---

**A01045 Configuring data invalid**

<b>Reaction:</b>	NONE
<b>Acknowledge:</b>	NONE
<b>Cause:</b>	<p>An error was detected when evaluating the parameter files PSxxxxxy.ACX, PTxxxxyy.ACX, CAxxxxyy.ACX, or CCxxxxyy.ACX saved in the non-volatile memory. Because of this, under certain circumstances, several of the saved parameter values were not able to be accepted. Also see r9406 up to r9408.</p> <p>Alarm value (r2124, interpret hexadecimal):</p> <p>Only for internal Siemens troubleshooting.</p>
<b>Remedy:</b>	<ul style="list-style-type: none"> <li>- check the parameters displayed in r9406 up to r9408, and correct these if required.</li> <li>- Restore the factory setting using (p0970 = 1) and re-load the project into the drive unit.</li> </ul> <p>Then save the parameterization with p0971 = 1. This overwrites the incorrect parameter files in the non-volatile memory – and the alarm is withdrawn.</p> <p>See also: r9406 (PS file parameter number parameter not transferred), r9407 (PS file parameter index parameter not transferred), r9408 (PS file fault code parameter not transferred)</p>

---

**A01049 It is not possible to write to file**

<b>Reaction:</b>	NONE
<b>Acknowledge:</b>	NONE

9.6 List of fault codes and alarm codes

**Cause:** It is not possible to write into a write-protected file (PSxxxxx.acx). The write request was interrupted.  
Alarm value (r2124, interpret decimal):  
Drive object number.

**Remedy:** Check whether the "write protected" attribute has been set for the files in the non-volatile memory under .../USER/SINAMICS/DATA/... When required, remove write protection and save again (e.g. set p0971 to 1).

---

**F01054 CU: System limit exceeded**

**Reaction:** OFF2

**Acknowledge:** IMMEDIATELY

**Cause:** At least one system overload has been identified.

Fault value (r0949, interpret decimal):

1: Computing time load too high (r9976[1]).

5: Peak load too high (r9976[5]).

Note:

As long as this fault is present, it is not possible to save the parameters (p0971).

See also: r9976 (System utilization)

**Remedy:** For fault value = 1, 5:

- reduce the computing time load of the drive unit (r9976[1] and r9976[5]) to under 100 %.

- check the sampling times and adjust if necessary (p0115, p0799, p4099).

- deactivate function modules.

- deactivate drive objects.

- remove drive objects from the target topology.

- note the DRIVE-CLiQ topology rules and if required, change the DRIVE-CLiQ topology.

When using the Drive Control Chart (DCC) or free function blocks (FBLOCKS), the following applies:

- the computing time load of the individual run-time groups on a drive object can be read out in r21005 (DCC) or r20005 (FBLOCKS).

- if necessary, the assignment of the run-time group (p21000, p20000) can be changed in order to increase the sampling time (r21001, r20001).

- if necessary, reduce the number of cyclically calculated blocks (DCC) and/or function blocks (FBLOCKS).

---

**A01066 Buffer memory: 70% fill level reached or exceeded**

**Reaction:** NONE

**Acknowledge:** NONE

**Cause:** The non-volatile buffer memory for parameter changes is filled to at least 70%.

This can also occur if the buffer memory is active (p0014 = 1) and parameters are continually changed via a fieldbus system.

**Remedy:** If required, deactivate and clear the buffer memory (p0014 = 0).

If required, clear the buffer memory (p0014 = 2).

In the following cases, the entries in the buffer memory are transferred into the ROM and then the buffer memory is cleared:

- p0971 = 1

- switch-off/switch-on Control Unit

See also: p0014 (Buffer memory mode)

---

**A01067 Buffer memory: 100 % fill level reached**

**Reaction:** NONE

**Acknowledge:** NONE

**Cause:** The non-volatile buffer memory for parameter changes is filled to 100%.

All additional parameter changes will no longer be taken into account in the non-volatile buffer memory. However, parameter changes can still be made in the volatile memory (RAM).

This can also occur if the buffer memory is active (p0014 = 1) and parameters are continually changed via a fieldbus system.



**Remedy:** If required, deactivate and clear the buffer memory (p0014 = 0).  
 If required, clear the buffer memory (p0014 = 2).  
 In the following cases, the entries in the buffer memory are transferred into the ROM and then the buffer memory is cleared:  
 - p0971 = 1  
 - switch-off/switch-on Control Unit  
 See also: p0014 (Buffer memory mode)

---

**F01068 CU: Data memory memory overflow**

**Reaction:** OFF2  
**Acknowledge:** IMMEDIATELY  
**Cause:** The utilization for a data memory area is too large.  
 Fault value (r0949, interpret binary):  
 Bit 0 = 1: High-speed data memory 1 overloaded  
 Bit 1 = 1: High-speed data memory 2 overloaded  
 Bit 2 = 1: High-speed data memory 3 overloaded  
 Bit 3 = 1: High-speed data memory 4 overloaded

**Remedy:** - deactivate the function module.  
 - deactivate drive object.  
 - remove the drive object from the target topology.

---

**A01069 Parameter backup and device incompatible**

**Reaction:** NONE  
**Acknowledge:** NONE  
**Cause:** The parameter backup on the memory card and the drive unit do not match.  
 The module boots with the factory settings.  
 Example:

Devices A and B. are not compatible and a memory card with the parameter backup for device A is inserted in device B.  
**Remedy:** - insert a memory card with compatible parameter backup and carry out a POWER ON.  
 - insert a memory card without parameter backup and carry out a POWER ON.  
 - if required, withdraw the memory card and carry out POWER ON.  
 - save the parameters (p0971 = 1).

---

**F01072 Memory card restored from the backup copy**

**Reaction:** NONE  
**Acknowledge:** IMMEDIATELY  
**Cause:** The Control Unit was switched-off while writing to the memory card. This is why the visible partition became defective.  
 After switching on, the data from the non-visible partition (backup copy) were written to the visible partition.  
**Remedy:** Check that the firmware and parameterization is up-to-date.

---

**A01073 (N) POWER ON required for backup copy on memory card**

**Reaction:** NONE  
**Acknowledge:** NONE  
**Cause:** The parameter assignment on the visible partition of the memory card has changed.  
 In order that the backup copy on the memory card is updated on the non-visible partition, it is necessary to carry out a POWER ON or hardware reset (p0972) of the Control Unit.  
 Note:  
 It is possible that a new POWER ON is requested via this alarm (e.g. after saving with p0971 = 1).  
**Remedy:** - carry out a POWER ON (power off/on) for the Control Unit.  
 - carry out a hardware reset (RESET button, p0972).

---

**A01098**      **RTC: Date and time setting required**

**Reaction:** NONE

**Acknowledge:** NONE

**Cause:** The power supply for the Control Unit was interrupted for an extended period. The date and time displayed on the real-time clock are no longer accurate.

**Note:**

This alarm is only output when p8405 = 1 (factory setting).

See also: p8405 (Activate/deactivate RTC alarm A01098)

**Remedy:** Set the date and time on the real-time clock.

**Note:**

RTC: Real-time clock

See also: p8400 (RTC time), p8401 (RTC date)

---

**N01101 (A)**      **CU: memory card not available**

**Reaction:** NONE

**Acknowledge:** NONE

**Cause:** The memory card is not available for the drive.

**Remedy:** Insert a memory card.

---

**F01105 (A)**      **CU: Insufficient memory**

**Reaction:** OFF1

**Acknowledge:** POWER ON

**Cause:** Too many data sets are configured on this Control Unit.

Fault value (r0949, interpret decimal):

Only for internal Siemens troubleshooting.

**Remedy:** - reduce the number of data sets.

---

**F01107**      **Save to memory card unsuccessful**

**Reaction:** NONE

**Acknowledge:** IMMEDIATELY

**Cause:** A data save to the memory card was not able to be successfully carried out.

- Memory card defective

- insufficient space on memory card.

Fault value (r0949, interpret decimal):

1: The file on the RAM was not able to be opened.

2: The file on the RAM was not able to be read.

3: A new directory could not be created on the memory card.

4: A new file could not be created on the memory card.

5: A new file could not be written on the memory card.

**Remedy:** - try to save again.

- replace the memory card or Control Unit.

---

**F01112**      **CU: Power unit not permissible**

**Reaction:** NONE

**Acknowledge:** IMMEDIATELY

**Cause:** The connected power unit cannot be used together with this Control Unit.

Fault value (r0949, interpret decimal):

1: Power unit is not supported (e.g. PM340).

**Remedy:** Replace the power unit that is not permissible by a component that is permissible.

---

---

<b>F01120 (A)</b>	<b>Terminal initialization has failed</b>
<b>Reaction:</b>	OFF1 (OFF2)
<b>Acknowledge:</b>	IMMEDIATELY (POWER ON)
<b>Cause:</b>	An internal software error occurred while the terminal functions were being initialized. Fault value (r0949, interpret hexadecimal): Only for internal Siemens troubleshooting.
<b>Remedy:</b>	<ul style="list-style-type: none"><li>- carry out a POWER ON (switch-off/switch-on) for all components.</li><li>- upgrade firmware to later version.</li><li>- contact Technical Support.</li><li>- replace the Control Unit.</li></ul>

---

<b>F01152</b>	<b>CU: Invalid constellation of drive object types</b>
<b>Reaction:</b>	NONE
<b>Acknowledge:</b>	POWER ON
<b>Cause:</b>	It is not possible to simultaneously operate drive object types SERVO, VECTOR and HLA. A maximum of 2 of these drive object types can be operated on a Control Unit.
<b>Remedy:</b>	<ul style="list-style-type: none"><li>- switch off the unit.</li><li>- restrict the use of drive object types SERVO, VECTOR, HLA to a maximum of 2.</li><li>- re-commission the unit.</li></ul>

---

<b>F01205</b>	<b>CU: Time slice overflow</b>
<b>Reaction:</b>	OFF2
<b>Acknowledge:</b>	POWER ON
<b>Cause:</b>	Insufficient computation time. Fault value (r0949, interpret hexadecimal): Only for internal Siemens troubleshooting.
<b>Remedy:</b>	Contact Technical Support.

---

<b>F01250</b>	<b>CU: CU-EEPROM incorrect read-only data</b>
<b>Reaction:</b>	NONE (OFF2)
<b>Acknowledge:</b>	POWER ON
<b>Cause:</b>	Error when reading the read-only data of the EEPROM in the Control Unit. Fault value (r0949, interpret decimal): Only for internal Siemens troubleshooting.
<b>Remedy:</b>	<ul style="list-style-type: none"><li>- carry out a POWER ON.</li><li>- replace the Control Unit.</li></ul>

---

<b>A01251</b>	<b>CU: CU-EEPROM incorrect read-write data</b>
<b>Reaction:</b>	NONE
<b>Acknowledge:</b>	NONE
<b>Cause:</b>	Error when reading the read-write data of the EEPROM in the Control Unit. Alarm value (r2124, interpret decimal): Only for internal Siemens troubleshooting.
<b>Remedy:</b>	For alarm value r2124 < 256, the following applies: <ul style="list-style-type: none"><li>- carry out a POWER ON.</li><li>- replace the Control Unit.</li></ul> For alarm value r2124 >= 256, the following applies: <ul style="list-style-type: none"><li>- clear the fault memory (p0952 = 0).</li><li>- replace the Control Unit.</li></ul>

---

---

**F01257 CU: Firmware version out of date**

**Reaction:** OFF2

**Acknowledge:** POWER ON

**Cause:** The Control Unit firmware is too old.  
Fault value (r0949, interpret hexadecimal):  
bbbbbbaa hex: aa = unsupported component  
aa = 01 hex = 1 dec:  
The firmware being used does not support the Control Unit.  
aa = 02 hex = 2 dec:  
The firmware being used does not support the Control Unit.  
aa = 03 hex = 3 dec:  
The firmware being used does not support the Power Module.  
aa = 04 hex = 4 dec:  
The firmware being used does not support the Control Unit.

**Remedy:** For fault value = 1, 2, 4:  
- Upgrade the firmware of the Control Unit.  
For fault value = 3:  
- Upgrade the firmware of the Control Unit.  
- Replace the Power Module by a component that is supported.

---

**F01340 Topology: Too many components on one line**

**Reaction:** NONE

**Acknowledge:** IMMEDIATELY

**Cause:** For the selected communications clock cycle, too many DRIVE-CLiQ components are connected to one line of the Control Unit.  
Fault value (r0949, interpret hexadecimal):  
xyy hex: x = fault cause, yy = component number or connection number.  
1yy:  
The communications clock cycle of the DRIVE-CLiQ connection on the Control Unit is not sufficient for all read transfers.  
2yy:  
The communications clock cycle of the DRIVE-CLiQ connection on the Control Unit is not sufficient for all write transfers.  
3yy:  
Cyclic communication is fully utilized.  
4yy:  
The DRIVE-CLiQ cycle starts before the earliest end of the application. An additional dead time must be added to the control. Sign-of-life errors can be expected.  
The conditions of operation with a current controller sampling time of 31.25 µs have not been maintained.  
5yy:  
Internal buffer overflow for net data of a DRIVE-CLiQ connection.  
6yy:  
Internal buffer overflow for receive data of a DRIVE-CLiQ connection.  
7yy:  
Internal buffer overflow for send data of a DRIVE-CLiQ connection.  
8yy:  
The component clock cycles cannot be combined with one another  
900:  
The lowest common multiple of the clock cycles in the system is too high to be determined.  
901:  
The lowest common multiple of the clock cycles in the system cannot be generated with the hardware.

- Remedy:**
- check the DRIVE-CLiQ wiring.
  - reduce the number of components on the DRIVE-CLiQ line involved and distribute these to other DRIVE-CLiQ sockets of the Control Unit. This means that communication is uniformly distributed over several lines.
- For fault value = 1yy - 4yy in addition:
- increase the sampling times (p0112, p0115, p4099). If necessary, for DCC or FBLOCKS, change the assignment of the run-time group (p21000, p20000) so that the sampling time (r21001, r20001) is increased.
  - if necessary, reduce the number of cyclically calculated blocks (DCC) and/or function blocks (FBLOCKS).
  - reduce the function modules (r0108).
  - establish the conditions for operation with a current controller sampling time of 31.25  $\mu$ s (at the DRIVE-CLiQ line, only operate Motor Modules and Sensor Modules with this sampling time and only use a permitted Sensor Module (e.g. SMC20, this means a 3 at the last position of the order number)).
  - For an NX, the corresponding Sensor Module for a possibly existing second measuring system should be connected to a free DRIVE-CLiQ socket of the NX.
- For fault value = 8yy in addition:
- check the clock cycles settings (p0112, p0115, p4099). Clock cycles on a DRIVE-CLiQ line must be perfect integer multiples of one another. As clock cycle on a line, all clock cycles of all drive objects in the previously mentioned parameters apply, which have components on the line involved.
- For fault value = 9yy in addition:
- check the clock cycles settings (p0112, p0115, p4099). The lower the numerical value difference between two clock cycles, the higher the lowest common multiple. This behavior has a significantly stronger influence, the higher the numerical values of the clock cycles.

---

**F01505 (A) BICO: Interconnection cannot be established**

- Reaction:** NONE
- Acknowledge:** IMMEDIATELY
- Cause:** A PROFIdrive telegram has been set (p0922).  
An interconnection contained in the telegram was not able to be established.  
Fault value (r0949, interpret decimal):  
Parameter receiver that should be changed.
- Remedy:** Establish another interconnection.

---

**F01510 BICO: Signal source is not float type**

- Reaction:** NONE
- Acknowledge:** IMMEDIATELY
- Cause:** The requested connector output does not have the correct data type. This interconnection is not established.  
Fault value (r0949, interpret decimal):  
Parameter number to which an interconnection should be made (connector output).
- Remedy:** Interconnect this connector input with a connector output having a float data type.

---

**F01511 (A) BICO: Interconnection with different scalings**

- Reaction:** NONE
- Acknowledge:** IMMEDIATELY

9.6 List of fault codes and alarm codes

---

**Cause:** The requested BICO interconnection was established. However, a conversion is made between the BICO output and BICO input using the reference values.  
- the BICO output has different normalized units than the BICO input.  
- message only for interconnections within a drive object.  
Example:  
The BICO output has, as normalized unit, voltage and the BICO input has current.  
This means that the factor p2002/p2001 is calculated between the BICO output and the BICO input.  
p2002: contains the reference value for current  
p2001: contains the reference value for voltage  
Fault value (r0949, interpret decimal):  
Parameter number of the BICO input (signal sink).

**Remedy:** Not necessary.

---

**F01512 BICO: No scaling available**

**Reaction:** OFF2  
**Acknowledge:** POWER ON  
**Cause:** An attempt was made to determine a conversion factor for a scaling that does not exist.  
Fault value (r0949, interpret decimal):  
Unit (e.g. corresponding to SPEED) for which an attempt was made to determine a factor.

**Remedy:** Apply scaling or check the transfer value.

---

**F01513 (N, A) BICO: Interconnection cross DO with different scalings**

**Reaction:** NONE  
**Acknowledge:** IMMEDIATELY  
**Cause:** The requested BICO interconnection was established. However, a conversion is made between the BICO output and BICO input using the reference values.  
An interconnection is made between different drive objects and the BICO output has different normalized units than the BICO input or the normalized units are the same but the reference values are different.  
Example 1:  
BICO output with voltage normalized unit, BICO input with current normalized unit, BICO output and BICO input lie in different drive objects. This means that the factor p2002/p2001 is calculated between the BICO output and the BICO input.  
p2002: contains the reference value for current  
p2001: contains the reference value for voltage  
Example 2:  
BICO output with voltage normalized unit in drive object 1 (DO1), BICO input with voltage normalized unit in drive object 2 (DO2). The reference values for voltage (p2001) of the two drive objects have different values. This means that the factor p2001(DO1)/p2001(DO2) is calculated between the BICO output and the BICO input.  
p2001: contains the reference value for voltage, drive objects 1, 2  
Fault value (r0949, interpret decimal):  
Parameter number of the BICO input (signal sink).

**Remedy:** Not necessary.

---

**A01514 (F) BICO: Error when writing during a reconnect**

**Reaction:** NONE  
**Acknowledge:** NONE  
**Cause:** During a reconnect operation (e.g. while booting or downloading - but can also occur in normal operation) a parameter was not able to be written to.  
Example:  
When writing to BICO input with double word format (DWORD), in the second index, the memory areas overlap (e.g. p8861). The parameter is then reset to the factory setting.  
Alarm value (r2124, interpret decimal):  
Parameter number of the BICO input (signal sink).

**Remedy:** Not necessary.

---

**F01515 (A) BICO: Writing to parameter not permitted as the master control is active**

**Reaction:** NONE

**Acknowledge:** IMMEDIATELY

**Cause:** When changing the number of CDS or when copying from CDS, the master control is active.

**Remedy:** If required, return the master control and repeat the operation.

---

**A01590 (F) Drive: Motor maintenance interval expired**

**Reaction:** NONE

**Acknowledge:** NONE

**Cause:** The selected service/maintenance interval for this motor was reached.

Alarm value (r2124, interpret decimal):

Motor data set number.

See also: p0650 (Actual motor operating hours), p0651 (Motor operating hours maintenance interval)

**Remedy:** carry out service/maintenance and reset the service/maintenance interval (p0651).

---

**F01662 Error internal communications**

**Reaction:** OFF2

**Acknowledge:** POWER ON

**Cause:** A module-internal communication error has occurred.

Fault value (r0949, interpret hexadecimal):

Only for internal Siemens troubleshooting.

**Remedy:**

- carry out a POWER ON (switch-off/switch-on).
- check the electrical cabinet design and cable routing for EMC compliance
- check whether an impermissible voltage is connected at one of the digital outputs.
- check whether a digital output is loaded with an impermissible current.
- upgrade firmware to later version.
- contact Technical Support.

---

**A01900 (F) PROFIBUS: Configuration telegram error**

**Reaction:** NONE

**Acknowledge:** NONE

**Cause:** A PROFIBUS master attempts to establish a connection using an incorrect configuring telegram.

Alarm value (r2124, interpret decimal):

2: Too many PZD data words for input or output. The number of possible PZD is specified by the number of indices in r2050/p2051.

3: Uneven number of bytes for input or output.

211: Unknown parameterizing block.

Additional values:

Only for internal Siemens troubleshooting.

**Remedy:** Check the bus configuration on the master and the slave sides.

For alarm value = 2:

Check the number of data words for input and output.

For alarm value = 211:

Ensure offline version <= online version.

---

**F01910 (N, A) Fieldbus interface setpoint timeout**

**Reaction:** OFF3 (IASC/DCBRK, NONE, OFF1, OFF2, STOP2)

**Acknowledge:** IMMEDIATELY

9.6 List of fault codes and alarm codes

**Cause:** The reception of setpoints from the fieldbus interface has been interrupted.  
- bus connection interrupted.  
- communication partner switched off.  
CU230P-2 DP:  
- PROFIBUS master set into the STOP state.  
See also: p2040 (Fieldbus interface monitoring time), p2047 (PROFIBUS additional monitoring time)

**Remedy:** Ensure bus connection has been established and switch on communication partner.  
CU230P-2 BT, CU230P-2 HVAC:  
- if required, adapt p2040.  
CU230P-2 DP:  
- set the PROFIBUS master to the RUN state.  
- if the error is repeated, check the set response monitoring in the bus configuration (HW Config).  
- slave redundancy: For operation on a Y link, it must be ensured that "DP alarm mode = DPV1" is set in the slave parameterization.

---

**A01920 (F) PROFIBUS: Interruption cyclic connection**

**Reaction:** NONE  
**Acknowledge:** NONE  
**Cause:** The cyclic connection to the PROFIBUS master is interrupted.  
**Remedy:** Establish the PROFIBUS connection and activate the PROFIBUS master in the cyclic mode.  
**Note:**  
If there is no communication to a higher-level control system, then p2030 should be set = 0 to suppress this message.  
See also: p2030 (Field bus interface protocol selection)

---

**A01945 PROFIBUS: Connection to the Publisher failed**

**Reaction:** NONE  
**Acknowledge:** NONE  
**Cause:** For PROFIBUS peer-to-peer data transfer, the connection to at least one Publisher has failed.  
Alarm value (r2124, interpret binary):  
Bit 0 = 1: Publisher with address in r2077[0], connection failed.  
...  
Bit 15 = 1: Publisher with address in r2077[15], connection failed.  
**Remedy:** Check the PROFIBUS cables.  
See also: r2077 (PROFIBUS diagnostics peer-to-peer data transfer addresses)

---

**F01946 (A) PROFIBUS: Connection to the Publisher aborted**

**Reaction:** OFF1 (NONE, OFF2, OFF3)  
**Acknowledge:** IMMEDIATELY (POWER ON)  
**Cause:** The connection to at least one Publisher for PROFIBUS peer-to-peer data transfer in cyclic operation has been aborted.  
Fault value (r0949, interpret binary):  
Bit 0 = 1: Publisher with address in r2077[0], connection aborted.  
...  
Bit 15 = 1: Publisher with address in r2077[15], connection aborted.  
**Remedy:** - check the PROFIBUS cables.  
- check the state of the Publisher that has the aborted connection.  
See also: r2077 (PROFIBUS diagnostics peer-to-peer data transfer addresses)

---

**A02150 OA: Application cannot be loaded**

**Reaction:** NONE  
**Acknowledge:** NONE



**Cause:** The system was not able to load an OA application.  
Alarm value (r2124, interpret hexadecimal):  
16:  
The interface version in the DCB user library is not compatible to the DCC standard library that has been loaded.  
Only for internal Siemens troubleshooting.

**Remedy:** - carry out a POWER ON (switch-off/switch-on) for all components.  
- upgrade firmware to later version.  
- contact Technical Support.  
For alarm value = 16:  
Load a compatible DCB user library (compatible to the interface of the DCC standard library).  
Note:  
OA: Open Architecture  
DCB: Drive Control Block  
DCC: Drive Control Chart  
See also: r4950, r4955, p4956, r4957

---

**F02151 (A) OA: Internal software error**

**Reaction:** OFF2 (NONE, OFF1, OFF3)

**Acknowledge:** IMMEDIATELY (POWER ON)

**Cause:** An internal software error has occurred within an OA application.  
Fault value (r0949, interpret hexadecimal):  
Only for internal Siemens troubleshooting.

**Remedy:** - carry out a POWER ON (switch-off/switch-on) for all components.  
- upgrade firmware to later version.  
- contact Technical Support.  
- replace the Control Unit.  
Note:  
OA: Open Architecture  
See also: r4950, r4955, p4956, r4957

---

**F02152 (A) OA: Insufficient memory**

**Reaction:** OFF1

**Acknowledge:** IMMEDIATELY (POWER ON)

**Cause:** Too many functions have been configured on this Control Unit (e.g. too many drives, function modules, data sets, OA applications, blocks, etc.).  
Fault value (r0949, interpret decimal):  
Only for internal Siemens troubleshooting.

**Remedy:** - change the configuration on this Control Unit (e.g. fewer drives, function modules, data sets, OA applications, blocks, etc.).  
- use an additional Control Unit.  
Note:  
OA: Open Architecture

---

**F03000 NVRAM fault on action**

**Reaction:** NONE

**Acknowledge:** IMMEDIATELY

9.6 List of fault codes and alarm codes

---

**Cause:** A fault occurred during execution of action p7770 = 1 or 2 for the NVRAM data.  
Fault value (r0949, interpret hexadecimal):  
yyxx hex: yy = fault cause, xx = application ID  
yy = 1:  
The action p7770 = 1 is not supported by this version if Drive Control Chart (DCC) is activated for the drive object concerned.  
yy = 2:  
The data length of the specified application is not the same in the NVRAM and the backup.  
yy = 3:  
The data checksum in p7774 is not correct.  
yy = 4:  
No data available to load.

**Remedy:** - Perform the remedy according to the results of the troubleshooting.  
- if necessary, start the action again.

---

**F03001 NVRAM checksum incorrect**

**Reaction:** NONE  
**Acknowledge:** IMMEDIATELY  
**Cause:** A checksum error occurred when evaluating the non-volatile data (NVRAM) on the Control Unit.  
The NVRAM data affected was deleted.  
**Remedy:** Carry out a POWER ON (switch-off/switch-on) for all components.

---

**F03505 (N, A) Analog input wire breakage**

**Reaction:** OFF1 (NONE, OFF2)  
**Acknowledge:** IMMEDIATELY (POWER ON)  
**Cause:** The wire-break monitoring for an analog input has responded.  
The input value of the analog input has undershot the threshold value parameterized in p0761[0...3].  
p0756[0]: Analog input 0  
p0756[1]: Analog input 1  
p0756[2]: Analog input 2  
Fault value (r0949, interpret decimal):  
yxxx dec  
y = analog input (0 = analog input 0 (AI 0), 1 = analog input 1 (AI 1), 2 = analog input 2 (AI 2))  
xxx = component number (p0151)  
Note:  
For the following analog input type, the wire breakage monitoring is active:  
p0756[0...1] = 1 (2 ... 10 V with monitoring)  
p0756[0...2] = 3 (4 ... 20 mA with monitoring)

**Remedy:** - Check the connection to the signal source for interruptions.  
- check the magnitude of the injected current - it is possible that the infed signal is too low.  
Note:  
The input current measured by the analog input can be read in r0752[x].

---

**A03510 (F, N) Calibration data not plausible**

**Reaction:** NONE  
**Acknowledge:** NONE  
**Cause:** During booting, the calibration data for the analog inputs is read and checked with respect to plausibility.  
At least one calibration data point was determined to be invalid.

**Remedy:** - switch-off/switch-on the power supply for the Control Unit.  
**Note:**  
 If it reoccurs, then replace the module.  
 In principle, operation could continue.  
 The analog channel involved possibly does not achieve the specified accuracy.

---

### A03520 (F, N) Temperature sensor fault

**Reaction:** NONE

**Acknowledge:** NONE

**Cause:** When evaluating the temperature sensor, an error occurred.  
 It is expected that one of the following temperature sensors is connected via an analog input:  
 - LG-Ni1000 (p0756[2...3] = 6)  
 - PT1000 (p0756[2...3] = 7)  
 - DIN Ni 1k (p0756[2...3] = 10)  
 Alarm value (r2124, interpret decimal):  
 33: Analog input 2 (AI2) wire breakage or sensor not connected.  
 34: Analog input 2 (AI2) measured resistance too low (short circuit).  
 49: Analog input 3 (AI3) wire breakage or sensor not connected.  
 50: Analog input 3 (AI3) measured resistance too low (short circuit).  
 See also: p0756 (CU analog inputs type)

**Remedy:** - make sure that the sensor is connected correctly.  
 - check the sensor for correct function and if required, replace.  
 - change over the analog input to type "no sensor connected" (p0756 = 8).

---

### A05000 (N) Power unit: Overtemperature heat sink AC inverter

**Reaction:** NONE

**Acknowledge:** NONE

**Cause:** The alarm threshold for overtemperature at the inverter heat sink has been reached. The response is set using p0290.  
 If the heat sink temperature exceeds the value set in p0292[0], then fault F30004 is output.

**Remedy:** Check the following:  
 - is the ambient temperature within the defined limit values?  
 - have the load conditions and the load duty cycle been appropriately dimensioned?  
 - has the cooling failed?

---

### A05001 (N) Power unit: Overtemperature depletion layer chip

**Reaction:** NONE

**Acknowledge:** NONE

**Cause:** Alarm threshold for overtemperature of the power semiconductor in the AC converter has been reached.

**Note:**

- the response is set using p0290.
- if the temperature of the barrier layer increases by the value set in p0292[1], then fault F30025 is initiated.

**Remedy:** Check the following:  
 - is the ambient temperature within the defined limit values?  
 - have the load conditions and the load duty cycle been appropriately dimensioned?  
 - has the cooling failed?  
 - pulse frequency too high?  
 See also: r0037, p0290

---

### A05002 (N) Power unit: Air intake overtemperature

**Reaction:** NONE

9.6 List of fault codes and alarm codes

---

**Acknowledge:** NONE

**Cause:** For chassis power units, the following applies:  
The alarm threshold for the air intake overtemperature has been reached. For air-cooled power units, the threshold is 42 °C (hysteresis 2 K). The response is set using p0290.  
If the air intake temperature increases by an additional 13 K, then fault F30035 is output.

**Remedy:** Check the following:  
- is the ambient temperature within the defined limit values?  
- has the fan failed? Check the direction of rotation.

---

**A05003 (N) Power unit: Internal overtemperature**

**Reaction:** NONE

**Acknowledge:** NONE

**Cause:** For chassis power units, the following applies:  
The alarm threshold for internal overtemperature has been reached.  
If the temperature inside the power unit increases by an additional 5 K, then fault F30036 is triggered.

**Remedy:** Check the following:  
- is the ambient temperature within the defined limit values?  
- has the fan failed? Check the direction of rotation.

---

**A05004 (N) Power unit: Rectifier overtemperature**

**Reaction:** NONE

**Acknowledge:** NONE

**Cause:** The alarm threshold for the overtemperature of the rectifier has been reached. The response is set using p0290.  
If the temperature of the rectifier increases by an additional 5 K, then fault F30037 is triggered.

**Remedy:** Check the following:  
- is the ambient temperature within the defined limit values?  
- have the load conditions and the load duty cycle been appropriately dimensioned?  
- has the fan failed? Check the direction of rotation.  
- has a phase of the line supply failed?  
- is an arm of the supply (incoming) rectifier defective?

---

**A05006 (N) Power unit: Overtemperature thermal model**

**Reaction:** NONE

**Acknowledge:** NONE

**Cause:** The temperature difference between the chip and heat sink has exceeded the permissible limit value (blocksize power units only).  
Depending on p0290, an appropriate overload response is initiated.  
See also: r0037 (Power unit temperatures)

**Remedy:** Not necessary.  
The alarm disappears automatically once the limit value is undershot.  
Note:  
If the alarm does not disappear automatically and the temperature continues to rise, this can result in fault F30024.  
See also: p0290 (Power unit overload response)

---

**A05065 (F, N) Voltage measured values not plausible**

**Reaction:** NONE

**Acknowledge:** NONE

- Cause:** The voltage measurement does not supply any plausible values and is not used.  
Alarm value (r2124, interpret bitwise binary):  
Bit 1: Phase U  
Bit 2: Phase V  
Bit 3: Phase W
- Remedy:** The following parameterization must be made in order to deactivate the alarm:  
- Deactivate voltage measurement (p0247.0 = 0).  
- Deactivate flying restart with voltage measurement (p0247.5 = 0) and deactivate fast flying restart (p1780.11 = 0).

**F06310 (A) Supply voltage (p0210) incorrectly parameterized****Reaction:** NONE (OFF1, OFF2)**Acknowledge:** IMMEDIATELY (POWER ON)**Cause:** The measured DC voltage lies outside the tolerance range after precharging has been completed.

Permissible range:

$$1.16 * p0210 < r0070 < 1.6 * p0210$$

Note:

The fault can only be acknowledged when the drive is switched off.

See also: p0210 (Drive unit line supply voltage)

- Remedy:**
- check the parameterized supply voltage and if required change (p0210).
  - check the line supply voltage.
- See also: p0210 (Drive unit line supply voltage)

**F07011 Drive: Motor overtemperature****Reaction:** OFF2 (NONE, OFF1, OFF3, STOP2)**Acknowledge:** IMMEDIATELY**Cause:** KTY84/PT1000:The motor temperature has exceeded the fault threshold (p0605) or a timer after the alarm threshold was exceeded (p0604) has expired. The response parameterized in p0610 becomes active. The alarm is withdrawn if the response threshold for wire breakage or sensor not connected is exceeded ( $R > 2120 \text{ Ohm}$ ).

PTC or bimetallic NC contact:

The response threshold of 1650 Ohm was exceeded or the NC contact opened and a timer has expired. The response parameterized in p0610 becomes active.

Possible causes:

- motor is overloaded.
- motor ambient temperature too high.
- wire breakage or sensor not connected.

Fault value (r0949, interpret decimal):

200:

Motor temperature model 1 (I2t): temperature too high.

See also: p0351, p0604, p0605, p0606, p0612, p0613, p0617, p0618, p0619, p0625, p0626, p0627, p0628

- Remedy:**
- reduce the motor load.
  - check the ambient temperature and the motor ventilation.
  - check the wiring and the connection of the PTC or bimetallic NC contact.
- See also: p0351, p0604, p0605, p0606, p0612, p0617, p0618, p0619, p0625, p0626, p0627, p0628

**A07012 (N) Drive: Motor temperature model 1/3 overtemperature****Reaction:** NONE**Acknowledge:** NONE

9.6 List of fault codes and alarm codes

---

**Cause:** The motor temperature model 1/3 identified that the alarm threshold was exceeded.  
Hysteresis:2K.  
Alarm value (r2124, interpret decimal):  
200:  
Motor temperature model 1 (I2t): temperature too high.  
300:  
Motor temperature model 3: temperature too high.  
See also: r0034, p0351, p0605, p0611, p0612, p0613

**Remedy:** - check the motor load and if required, reduce.  
- check the motor ambient temperature.  
- check activation of the motor temperature model (p0612).  
Motor temperature model 1 (I2t):  
- check the thermal time constant (p0611).  
- check alarm threshold.  
Motor temperature model 3:  
- check the motor type.  
- check alarm threshold.  
- check the model parameters.  
See also: r0034, p0351, p0605, p0611, p0612, r5397

---

**A07014 (N) Drive: Motor temperature model configuration alarm**

**Reaction:** NONE

**Acknowledge:** NONE

**Cause:** A fault has occurred in the configuration of the motor temperature model.

Alarm value (r2124, interpret decimal):

1:

All motor temperature models: It is not possible to save the model temperature

See also: p0610 (Motor overtemperature response)

**Remedy:** - set the response for motor overtemperature to "Alarm and fault, no reduction of I\_max" (p0610 = 2).

See also: p0610 (Motor overtemperature response)

---

**A07015 Drive: Motor temperature sensor alarm**

**Reaction:** NONE

**Acknowledge:** NONE

**Cause:** An error was detected when evaluating the temperature sensor set in p0601.

With the fault, the time in p0607 is started. If the fault is still present after this time has expired, then fault F07016 is output; however, at the earliest, 50 ms after alarm A07015.

Possible causes:

- wire breakage or sensor not connected (KTY: R > 2120 Ohm, PT1000: R > 2120 Ohm).

- measured resistance too low (PTC: R < 20 Ohm, KTY: R < 50 Ohm, PT1000: R < 603 Ohm).

**Remedy:** - make sure that the sensor is connected correctly.

- check the parameterization (p0601).

See also: r0035 (Motor temperature), p0601 (Motor temperature sensor type), p0607 (Temperature sensor fault timer)

---

**F07016 Drive: Motor temperature sensor fault**

**Reaction:** OFF1 (NONE, OFF2, OFF3, STOP2)

**Acknowledge:** IMMEDIATELY

---

<b>Cause:</b>	An error was detected when evaluating the temperature sensor set in p0601. Possible causes: - wire breakage or sensor not connected (KTY: R > 2120 Ohm, PT1000: R > 2120 Ohm). - measured resistance too low (PTC: R < 20 Ohm, KTY: R < 50 Ohm, PT1000: R < 603 Ohm). Note: If alarm A07015 is present, the time in p0607 is started. If the fault is still present after this time has expired, then fault F07016 is output; however, at the earliest, 50 ms after alarm A07015. See also: p0607 (Temperature sensor fault timer)
<b>Remedy:</b>	- make sure that the sensor is connected correctly. - check the parameterization (p0601). - induction motors: Deactivate temperature sensor fault (p0607 = 0). See also: r0035 (Motor temperature), p0601 (Motor temperature sensor type), p0607 (Temperature sensor fault timer)

---

**F07080 Drive: Incorrect control parameter****Reaction:** NONE**Acknowledge:** IMMEDIATELY (POWER ON)**Cause:** The closed-loop control parameters have been parameterized incorrectly (e.g. p0356 = L\_spread = 0).

Fault value (r0949, interpret decimal):

The fault value includes the parameter number involved.

See also: p0310, p0311, p0341, p0344, p0350, p0354, p0356, p0357, p0358, p0360, p0400, p0640, p1082, p1300

**Remedy:** Modify the parameter indicated in the fault value (r0949) (e.g. p0640 = current limit > 0).

See also: p0311, p0341, p0344, p0350, p0354, p0356, p0358, p0360, p0400, p0640, p1082

**F07082 Macro: Execution not possible****Reaction:** NONE**Acknowledge:** IMMEDIATELY

9.6 List of fault codes and alarm codes

---

**Cause:** The macro cannot be executed.  
Fault value (r0949, interpret hexadecimal):  
ccccbbaa hex:  
cccc = preliminary parameter number, bb = supplementary information, aa = fault cause  
Fault causes for the trigger parameter itself:  
19: Called file is not valid for the trigger parameter.  
20: Called file is not valid for parameter 15.  
21: Called file is not valid for parameter 700.  
22: Called file is not valid for parameter 1000.  
23: Called file is not valid for parameter 1500.  
24: Data type of a TAG is incorrect (e.g. Index, number or bit is not U16).  
Fault causes for the parameters to be set:  
25: Error level has an undefined value.  
26: Mode has an undefined value.  
27: A value was entered as string in the tag value that is not "DEFAULT".  
31: Entered drive object type unknown.  
32: A device was not able to be found for the determined drive object number.  
34: A trigger parameter was recursively called.  
35: It is not permissible to write to the parameter via macro.  
36: Check, writing to a parameter unsuccessful, parameter can only be read, not available, incorrect data type, value range or assignment incorrect.  
37: Source parameter for a BICO interconnection was not able to be determined.  
38: An index was set for a non-indexed (or CDS-dependent) parameter.  
39: No index was set for an indexed parameter.  
41: A bit operation is only permissible for parameters with the parameter format DISPLAY\_BIN.  
42: A value not equal to 0 or 1 was set for a BitOperation.  
43: Reading the parameter to be changed by the BitOperation was unsuccessful.  
51: Factory setting for DEVICE may only be executed on the DEVICE.  
61: The setting of a value was unsuccessful.

**Remedy:** - check the parameter involved.  
- check the macro file and BICO interconnection.  
See also: p0015, p0700, p1000, p1500

---

**F07083 Macro: ACX file not found**

**Reaction:** NONE

**Acknowledge:** IMMEDIATELY

**Cause:** The ACX file (macro) to be executed was not able to be found in the appropriate directory.  
Fault value (r0949, interpret decimal):  
Parameter number with which the execution was started.  
See also: p0015, p0700, p1000, p1500

**Remedy:** - check whether the file is saved in the appropriate directory on the memory card.

---

**F07084 Macro: Condition for WaitUntil not fulfilled**

**Reaction:** NONE

**Acknowledge:** IMMEDIATELY

**Cause:** The WaitUntil condition set in the macro was not fulfilled in a certain number of attempts.  
Fault value (r0949, interpret decimal):  
Parameter number for which the condition was set.

**Remedy:** Check and correct the conditions for the WaitUntil loop.



---

<b>F07086</b>	<b>Units changeover: Parameter limit violation due to reference value change</b>
<b>Reaction:</b>	NONE
<b>Acknowledge:</b>	IMMEDIATELY
<b>Cause:</b>	<p>A reference parameter was changed in the system. This resulted in the fact that for the parameters involved, the selected value was not able to be written in the per unit notation.</p> <p>The values of the parameters were set to the corresponding violated minimum limit/maximum limit or to the factory setting.</p> <p>Possible causes:</p> <ul style="list-style-type: none"> <li>- the steady-state minimum limit/maximum limit or that defined in the application was violated.</li> </ul> <p>Fault value (r0949, parameter):</p> <p>Diagnostics parameter to display the parameters that were not able to be re-calculated.</p> <p>See also: p0304, p0305, p0310, p0596, p2000, p2001, p2002, p2003, r2004</p>
<b>Remedy:</b>	<p>Check the adapted parameter value and if required correct.</p> <p>See also: r9450 (Reference value change parameter with unsuccessful calculation)</p>

---

<b>F07088</b>	<b>Units changeover: Parameter limit violation due to units changeover</b>
<b>Reaction:</b>	NONE
<b>Acknowledge:</b>	IMMEDIATELY
<b>Cause:</b>	<p>A changeover of units was initiated. This resulted in a violation of a parameter limit</p> <p>Possible causes for the violation of a parameter limit:</p> <ul style="list-style-type: none"> <li>- When rounding off a parameter corresponding to its decimal places, the steady-state minimum limit or maximum limit was violated.</li> <li>- inaccuracies for the data type "FloatingPoint".</li> </ul> <p>In these cases, when the minimum limit is violated then the parameter value is rounded up and when the maximum limited is violated the parameter value is rounded down.</p> <p>Fault value (r0949, interpret decimal):</p> <p>Diagnostics parameter r9451 to display all parameters whose value had to be adapted.</p> <p>See also: p0100 (IEC/NEMA Standards), p0505 (Selecting the system of units), p0595 (Technological unit selection)</p>
<b>Remedy:</b>	<p>Check the adapted parameter values and if required correct.</p> <p>See also: r9451 (Units changeover adapted parameters)</p>

---

<b>A07089</b>	<b>Changing over units: Function module activation is blocked because the units have been changed over</b>
<b>Reaction:</b>	NONE
<b>Acknowledge:</b>	NONE
<b>Cause:</b>	<p>An attempt was made to activate a function module. This is not permissible if the units have already been changed over.</p> <p>See also: p0100 (IEC/NEMA Standards), p0505 (Selecting the system of units)</p>
<b>Remedy:</b>	Restore units that have been changed over to the factory setting.

---

<b>A07094</b>	<b>General parameter limit violation</b>
<b>Reaction:</b>	NONE
<b>Acknowledge:</b>	NONE
<b>Cause:</b>	<p>As a result of the violation of a parameter limit, the parameter value was automatically corrected.</p> <p>Minimum limit violated --&gt; parameter is set to the minimum value.</p> <p>Maximum limit violated --&gt; parameter is set to the maximum value.</p> <p>Alarm value (r2124, interpret decimal):</p> <p>Parameter number, whose value had to be adapted.</p>
<b>Remedy:</b>	Check the adapted parameter values and if required correct.

---

<b>A07200</b>	<b>Drive: Master control ON command present</b>
<b>Reaction:</b>	NONE

9.6 List of fault codes and alarm codes

---

**Acknowledge:** NONE  
**Cause:** The ON/OFF1 command is present (no 0 signal).  
The command is either influenced via binector input p0840 (current CDS) or control word bit 0 via the master control.  
**Remedy:** Switch the signal via binector input p0840 (current CDS) or control word bit 0 via the master control to 0.

---

**F07220 (N, A) Drive: Master control by PLC missing**

**Reaction:** OFF1 (NONE, OFF2, OFF3, STOP2)  
**Acknowledge:** IMMEDIATELY  
**Cause:** The "master control by PLC" signal was missing in operation.  
- interconnection of the binector input for "master control by PLC" is incorrect (p0854).  
- the higher-level control has withdrawn the "master control by PLC" signal.  
- data transfer via the fieldbus (master/drive) was interrupted.  
**Remedy:** - check the interconnection of the binector input for "master control by PLC" (p0854).  
- check the "master control by PLC" signal and, if required, switch in.  
- check the data transfer via the fieldbus (master/drive).  
**Note:**  
If the drive should continue to operate after withdrawing "master control by PLC" then fault response must be parameterized to NONE or the message type should be parameterized as alarm.

---

**F07300 (A) Drive: Line contactor feedback signal missing**

**Reaction:** OFF2 (NONE)  
**Acknowledge:** IMMEDIATELY  
**Cause:** - the line contactor was not able to be closed within the time in p0861.  
- the line contactor was not able to be opened within the time in p0861.  
- the line contactor dropped out during operation  
- the line contactor has closed although the drive converter is switched off.  
**Remedy:** - check the setting of p0860.  
- check the feedback circuit from the line contactor.  
- increase the monitoring time in p0861.  
See also: p0860 (Line contactor feedback signal), p0861 (Line contactor monitoring time)

---

**F07311 Bypass motor switch**

**Reaction:** OFF2  
**Acknowledge:** IMMEDIATELY  
**Cause:** Fault value (r0949, interpret bitwise binary):  
Bit 1: Switch "Closed" feedback signal missing.  
Bit 2: Switch "Open" feedback signal missing.  
Bit 3: Switch feedback signal too slow.  
After switching, the system waits for the positive feedback signal. If the feedback signal is received later than the specified time, then a fault trip (shutdown) is issued.  
Bit 6: Drive switch feedback signal not consistent with the bypass state.  
The drive switch is closed when switching-on or when switching-in the motor.  
See also: p1260, r1261, p1266, p1267, p1269, p1274  
**Remedy:** - check the transfer of the feedback signals.  
- check the switch.

---

**F07312 Bypass Line Side Switch:**

**Reaction:** OFF2  
**Acknowledge:** IMMEDIATELY

**Cause:** Fault value (r0949, interpret bitwise binary):  
 Bit 1: Switch "Closed" feedback signal missing.  
 Bit 2: Switch "Open" feedback signal missing.  
 Bit 3: Switch feedback signal too slow.  
 After switching, the system waits for the positive feedback signal. If the feedback signal is received later than the specified time, then a fault trip (shutdown) is issued.  
 Bit 6: Line Side Switch feedback signal not consistent with the bypass state.  
 When switching-on or when switching-in the motor, the line side switch is closed without this having been requested from the bypass.  
 See also: p1260, r1261, p1266, p1267, p1269, p1274

**Remedy:**

- check the transfer of the feedback signals.
- check the switch.

---

### **F07320 Drive: Automatic restart interrupted**

**Reaction:** OFF2

**Acknowledge:** IMMEDIATELY

**Cause:**

- the specified number of restart attempts (p1211) has been completely used up because within the monitoring time (p1213) the faults were not able to be acknowledged. The number of restart attempts (p1211) is decremented at each new start attempt.
- the monitoring time for the power unit has expired (p0857).
- when exiting commissioning or at the end of the motor identification routine or the speed controller optimization, the drive unit is not automatically switched on again.

Fault value (r0949, interpret hexadecimal):  
 Only for internal Siemens troubleshooting.

**Remedy:**

- increase the number of restart attempts (p1211). The actual number of starting attempts is displayed in r1214.
- increase the delay time in p1212 and/or the monitoring time in p1213.
- either increase or disable the monitoring time of the power unit (p0857).
- reduce the delay time to reset the start counter (p1213[1]) so that fewer faults are registered in the time interval.

---

### **A07321 Drive: Automatic restart active**

**Reaction:** NONE

**Acknowledge:** NONE

**Cause:** The automatic restart (AR) is active. When the line supply returns and/or the causes of the existing faults are removed the drive is automatically restarted. The pulses are enabled and the motor starts to rotate.  
 For p1210 = 26, restarting is realized with the delayed setting of the ON command.

**Remedy:**

- the automatic restart (AR) should, if required, be inhibited (p1210 = 0).
- an automatic restart can be directly interrupted by withdrawing the switch-on command (BI: p0840).
- for p1210 = 26: by withdrawing the OFF2- / OFF3 command.

---

### **A07325 Drive: Hibernation mode active - drive automatically switched-on again**

**Reaction:** NONE

**Acknowledge:** NONE

**Cause:** The "hibernation" function is active (p2398). The drive automatically powers itself up again as soon as the restart conditions are present.  
 See also: p2398 (Hibernation mode operating type), r2399 (Hibernation mode status words)

**Remedy:** Not necessary.  
 The alarm is automatically withdrawn when the motor is restarted or when the motor is manually switched off.

---

### **F07330 Flying restart: Measured search current too low**

**Reaction:** OFF2 (NONE, OFF1)

**Acknowledge:** IMMEDIATELY

9.6 List of fault codes and alarm codes

---

**Cause:** During a flying restart, it was identified that the search current reached is too low.  
It is possible that the motor is not connected.

**Remedy:** Check the motor feeder cables.

---

**F07331 Flying restart: Function not supported**

**Reaction:** OFF2 (NONE, OFF1)

**Acknowledge:** IMMEDIATELY

**Cause:** It is not possible to power up with the motor rotating (no flying restart).  
In the following cases, the "flying restart" function is not supported:  
PMSM: operation with *U/f* characteristic and sensorless vector control.  
Note:

PMSM: permanent-magnet synchronous motor  
**Remedy:** Deactivate the "flying restart" function (p1200 = 0).

---

**F07332 Flying restart: maximum speed reduced**

**Reaction:** OFF2 (NONE, OFF1)

**Acknowledge:** IMMEDIATELY

**Cause:** The maximum speed that can be reached is reduced; at very high speeds problems associated with the flying restart can be encountered.  
Possible causes:

- power ratio, power unit/motor too high  
**Remedy:** Parameter changes are not required.  
Note:  
A flying restart at speeds above 3000 rpm should be avoided.

---

**A07352 Drive: Limit switch signals not plausible**

**Reaction:** NONE

**Acknowledge:** NONE

**Cause:** Limit switch signals are not plausible.  
Possible causes:  
- BICO interconnections are not OK (p3342, p3343).  
- sensors are not supplying a valid signal (both supply a 0 signal).

**Remedy:** - check the BICO interconnections for the limit switch signals.  
- check the sensors.  
See also: p3342 (Limit switch plus), p3343 (Limit switch minus)

---

**A07353 Drive: DC quantity control deactivated**

**Reaction:** NONE

**Acknowledge:** NONE

**Cause:** The DC quantity control has deactivated itself.  
The manipulated variable of the DC quantity control was at its limit.

**Remedy:** Optimize the DC quantity controller (Kp, Tn, bandwidth, PT2 filter).  
Note:  
After changing the corresponding parameters, the DC quantity control is re-enabled and the alarm is automatically withdrawn.  
See also: p3857, p3858

---

**F07390 Drive: DC link capacitor forming fault**

**Reaction:** OFF2

**Acknowledge:** IMMEDIATELY

**Cause:** The "DC link capacitor forming" function was canceled with fault (r3382.3 = 1). The expected DC link voltage is out of tolerance.

See also: p3380 (Forming activation/duration), r3382 (Forming status word)

**Remedy:**

- check drive device (supply voltage, terminals, ...).
- set activation/duration again (p3380 > 0).
- restart forming (p0840 = 0/1 signal).

**A07391 Drive: DC link capacitor forming active**

**Reaction:** NONE

**Acknowledge:** NONE

**Cause:** The "DC link capacitor forming" function is active. The remaining time of the operation is displayed in parameter r3381. See also: p3380 (Forming activation/duration)

**Remedy:** Not necessary.  
The alarm is automatically withdrawn after forming has been completed (r3382.2 = 1).  
See also: r3382 (Forming status word)

**A07400 (N) Drive: DC link voltage maximum controller active**

**Reaction:** NONE

**Acknowledge:** NONE

**Cause:** The DC link voltage controller has been activated because the upper switch-in threshold has been exceeded (r1242, r1282).

The ramp-down times are automatically increased in order to maintain the DC link voltage (r0070) within the permissible limits. There is a system deviation between the setpoint and actual speeds.

When the DC link voltage controller is switched out (disabled), this is the reason that the ramp-function generator output is set to the speed actual value.

See also: r0056 (Status word, closed-loop control), p1240 (Vdc controller configuration (vector control)), p1280 (Vdc controller configuration (U/f))

**Remedy:** If the controller is not to intervene:

- increase the ramp-down times.
- switch off the Vdc\_max controller (p1240 = 0 for vector control, p1280 = 0 for U/f control).

If the ramp-down times are not to be changed:

- use a chopper or regenerative feedback unit.

**A07401 (N) Drive: DC link voltage maximum controller deactivated**

**Reaction:** NONE

**Acknowledge:** NONE

**Cause:** The Vdc\_max controller can no longer maintain the DC link voltage (r0070) below the limit value (r1242, r1282) and was therefore switched out (disabled).

- the line supply voltage is permanently higher than specified for the power unit.
- the motor is permanently in the regenerative mode as a result of a load that is driving the motor.

**Remedy:**

- check whether the input voltage is within the permissible range (if required, increase the value in p0210).
- check whether the load duty cycle and load limits are within the permissible limits.

**A07402 (N) Drive: DC link voltage minimum controller active**

**Reaction:** NONE

**Acknowledge:** NONE

**Cause:** The DC link voltage controller has been activated as the lower switch-in threshold has been undershot (r1246, r1286).

The kinetic energy of the motor is used to buffer the DC link. The drive is therefore braked.

See also: r0056 (Status word, closed-loop control), p1240 (Vdc controller configuration (vector control)), p1280 (Vdc controller configuration (U/f))

**Remedy:** The alarm disappears when power supply returns.

---

**F07405 (N, A) Drive: Kinetic buffering minimum speed fallen below**

**Reaction:** OFF2 (IASC/DCBRK, NONE, OFF1, OFF3, STOP2)

**Acknowledge:** IMMEDIATELY

**Cause:** During kinetic buffering the speed fell below minimum speed (p1257 or p1297 for vector drives with U/f control) and the line supply did not return.

**Remedy:** Check the speed threshold for the Vdc\_min controller (kinetic buffering) (p1257, p1297).  
See also: p1257 (Vdc\_min controller speed threshold), p1297 (Vdc\_min controller speed threshold (U/f))

---

**F07406 (N, A) Drive: Kinetic buffering maximum time exceeded**

**Reaction:** OFF3 (IASC/DCBRK, NONE, OFF1, OFF2, STOP2)

**Acknowledge:** IMMEDIATELY

**Cause:** The maximum buffer time (p1255 and p1295 for vector drives with U/f control) has been exceeded without the line supply having returned.

**Remedy:** Check the time threshold for Vdc-min controller (kinetic buffering) (p1255, p1295).  
See also: p1255 (Vdc\_min controller time threshold), p1295 (Vdc\_min controller time threshold (U/f))

---

**A07409 (N) Drive: U/f control, current limiting controller active**

**Reaction:** NONE

**Acknowledge:** NONE

**Cause:** The current limiting controller of the U/f control was activated because the current limit was exceeded.

**Remedy:** The alarm is automatically withdrawn after one of the following measures:

- increase current limit (p0640).
- reduce the load.
- slow down the ramp up to the setpoint speed.

---

**F07410 Drive: Current controller output limited**

**Reaction:** OFF2 (NONE, OFF1)

**Acknowledge:** IMMEDIATELY

**Cause:** The condition "I\_act = 0 and Uq\_set\_1 longer than 16 ms at its limit" is present and can be caused by the following:

- motor not connected or motor contactor open.
- motor data and motor configuration (star-delta) do not match.
- no DC link voltage present.
- power unit defective.
- the "flying restart" function is not activated.

**Remedy:**

- connect the motor or check the motor contactor.
- check the motor parameterization and the connection type (star-delta).
- check the DC link voltage (r0070).
- check the power unit.
- activate the "flying restart" function (p1200).

---

**F07411 Drive: Flux setpoint not reached when building up excitation**

**Reaction:** OFF2

**Acknowledge:** IMMEDIATELY

<b>Cause:</b>	When quick magnetizing is configured (p1401.6 = 1) the specified flux setpoint is not reached although 90% of the maximum current is specified. <ul style="list-style-type: none"> <li>- incorrect motor data.</li> <li>- motor data and motor configuration (star-delta) do not match.</li> <li>- the current limit has been set too low for the motor.</li> <li>- induction motor (encoderless, open-loop controlled) in I2t limiting.</li> <li>- power unit is too small.</li> <li>- the magnetizing time is too short.</li> </ul>
<b>Remedy:</b>	<ul style="list-style-type: none"> <li>- correct the motor data. Perform motor data identification and rotating measurement.</li> <li>- check the motor configuration.</li> <li>- correct the current limits (p0640).</li> <li>- reduce the induction motor load.</li> <li>- if necessary, use a larger power unit.</li> <li>- check motor supply cable.</li> <li>- check power unit.</li> <li>- increase p0346.</li> </ul>

---

#### **A07416 Drive: Flux controller configuration**

**Reaction:** NONE

**Acknowledge:** NONE

**Cause:** The configuration of the flux control (p1401) is contradictory.

Alarm value (r2124, interpret hexadecimal):

ccbbaaaa hex

aaaa = Parameter

bb = Index

cc = fault cause

1: Quick magnetizing (p1401.6) for soft starting (p1401.0).

2: Quick magnetizing for flux build-up control (p1401.2).

3: Quick magnetizing (p1401.6) for Rs identification after restart (p0621 = 2).

**Remedy:**

For fault cause = 1:

- Shut down soft start (p1401.0 = 0).

- Shut down quick magnetizing (p1401.6 = 0).

For fault cause = 2:

- switch-on flux build-up control (p1401.2 = 1).

- Shut down quick magnetizing (p1401.6 = 0).

For fault cause = 3:

- Re-parameterize Rs identification (p0621 = 0, 1)

- Shut down quick magnetizing (p1401.6 = 0).

---

#### **F07426 (A) Technology controller actual value limited**

**Reaction:** OFF1 (IASC/DCBRK, NONE, OFF2, OFF3)

**Acknowledge:** IMMEDIATELY

**Cause:** The actual value for the technology controller, interconnected via connector input p2264, has reached a limit.

Fault value (r0949, interpret decimal):

1: upper limit reached.

2: lower limit reached.

**Remedy:**

- adapt the limits to the signal level (p2267, p2268).

- check the actual value normalization (p0595, p0596).

See also: p0595, p0596, p2264, p2267, p2268

---

**A07427 Motor switch-in alarm**

**Reaction:** NONE

**Acknowledge:** NONE

**Cause:** Alarm value (r2124, interpret decimal):

1:

The technology controller is not active or is not being used to control the main setpoint (see p2251).

2:

The operating time limits have been exceeded in at least one external motor.

**Remedy:** For alarm value = 1:

- enable technology controller (p2200).

- set technology controller mode p2251 = 0 (main setpoint).

For alarm value = 2:

- increase p2381, p2382 or set p2380 = 0.

---

**A07428 (N) Technology controller parameterizing error**

**Reaction:** NONE

**Acknowledge:** NONE

**Cause:** The technology controller has a parameterizing error.

Alarm value (r2124, interpret decimal):

1:

The upper output limit in p2291 is set lower than the lower output limit in p2292.

**Remedy:** For alarm value = 1:

Set the output limit in p2291 higher than in p2292.

See also: p2291 (Technology controller maximum limiting), p2292 (Technology controller minimum limiting)

---

**F07435 (N) Drive: Setting the ramp-function generator for sensorless vector control**

**Reaction:** OFF2 (IASC/DCBRK, NONE, OFF1, OFF3)

**Acknowledge:** IMMEDIATELY

**Cause:** During operation with sensorless vector control (r1407.1) the ramp-function generator was stopped (p1141). An internal setting command of the ramp-function generator output caused the set setpoint speed to be frozen.

**Remedy:** - deactivate the holding command for the ramp-function generator (p1141).

- suppress the fault (p2101, p2119). This is necessary if the ramp-function generator is held using jogging and the speed setpoint is simultaneously inhibited (r0898.6).

---

**F07436 (A) Free tec\_ctrl 0 actual value limited**

**Reaction:** OFF1 (IASC/DCBRK, NONE, OFF2, OFF3)

**Acknowledge:** IMMEDIATELY

**Cause:** The actual value for the free technology controller 0 has reached the limit.

The signal source for the actual value is set via connector input p11064.

Fault value (r0949, interpret decimal):

1: The actual value has reached the upper limit.

2: The actual value has reached the lower limit.

**Remedy:** - adapt the limit settings to the actual value signal (p11067, p11068).

- check the scaling of the actual value signal.

- check the signal source setting for the actual value (p11064).

See also: p11064 (Free tec\_ctrl 0 actual value signal source), p11067 (Free tec\_ctrl 0 actual value upper limit), p11068 (Free tec\_ctrl 0 actual value lower limit)

---

**F07437 (A) Free tec\_ctrl 1 actual value limited**

**Reaction:** OFF1 (IASC/DCBRK, NONE, OFF2, OFF3)



---

**Acknowledge:** IMMEDIATELY

**Cause:** The actual value for the free technology controller 1 has reached the limit.  
The signal source for the actual value is set via connector input p11164.  
Fault value (r0949, interpret decimal):  
1: The actual value has reached the upper limit.  
2: The actual value has reached the lower limit.

**Remedy:** - adapt the limit settings to the actual value signal (p11167, p11168).  
- check the scaling of the actual value signal.  
- check the signal source setting for the actual value (p11164).  
See also: p11164 (Free tec\_ctrl 1 actual value signal source), p11167 (Free tec\_ctrl 1 actual value upper limit), p11168 (Free tec\_ctrl 1 actual value lower limit)

---

**F07438 (A) Free tec\_ctrl 2 actual value limited**

**Reaction:** OFF1 (IASC/DCBRK, NONE, OFF2, OFF3)

**Acknowledge:** IMMEDIATELY

**Cause:** The actual value for the free technology controller 2 has reached the limit.  
The signal source for the actual value is set via connector input p11264.  
Fault value (r0949, interpret decimal):  
1: The actual value has reached the upper limit.  
2: The actual value has reached the lower limit.

**Remedy:** - adapt the limit settings to the actual value signal (p11267, p11268).  
- check the scaling of the actual value signal.  
- check the signal source setting for the actual value (p11264).  
See also: p11264 (Free tec\_ctrl 2 actual value signal source), p11267 (Free tec\_ctrl 2 actual value upper limit), p11268 (Free tec\_ctrl 2 actual value lower limit)

---

**A07444 PID autotuning is activated**

**Reaction:** NONE

**Acknowledge:** NONE

**Cause:** Automatic setting of the PID controller parameters (PID autotuning) was activated (p2350).  
See also: p2350 (Enable PID autotuning)

**Remedy:** Not necessary.  
This alarm is automatically withdrawn after the PID autotuning has been completed.

---

**F07445 PID autotuning canceled**

**Reaction:** NONE

**Acknowledge:** IMMEDIATELY

**Cause:** The PID autotuning was canceled as a result of an error.

**Remedy:** - increase the offset.  
- check system configuration.

---

**A07530 Drive: Drive Data Set DDS not present**

**Reaction:** NONE

**Acknowledge:** NONE

**Cause:** The selected drive data set is not available (p0837 > p0180). The drive data set was not changed over.  
See also: p0180, p0820, p0821, p0822, p0823, p0824, r0837

**Remedy:** - select the existing drive data set.  
- set up additional drive data sets.

---

---

<b>A07531</b>	<b>Drive: Command Data Set CDS not present</b>
<b>Reaction:</b>	NONE
<b>Acknowledge:</b>	NONE
<b>Cause:</b>	The selected command data set is not available (p0836 > p0170). The command data set was not changed over. See also: p0810, p0811, p0812, p0813, r0836
<b>Remedy:</b>	- select the existing command data set. - set up additional command data sets.

---

<b>F07800</b>	<b>Drive: No power unit present</b>
<b>Reaction:</b>	NONE
<b>Acknowledge:</b>	IMMEDIATELY
<b>Cause:</b>	The power unit parameters cannot be read or no parameters are stored in the power unit. Note: This fault also occurs if an incorrect topology was selected in the commissioning software and this parameterization is then downloaded to the Control Unit. See also: r0200 (Power unit code number actual)
<b>Remedy:</b>	- carry out a POWER ON (switch-off/switch-on) for all components. - check the power unit and replace if necessary. - check the Control Unit, and if required replace it. - after correcting the topology, the parameters must be again downloaded using the commissioning software.

---

<b>F07801</b>	<b>Drive: Motor overcurrent</b>
<b>Reaction:</b>	OFF2 (NONE, OFF1, OFF3)
<b>Acknowledge:</b>	IMMEDIATELY
<b>Cause:</b>	The permissible motor limit current was exceeded. - effective current limit set too low. - current controller not correctly set. - U/f operation: Up ramp was set too short or the load is too high. - U/f operation: Short-circuit in the motor cable or ground fault. - U/f operation: Motor current does not match current of power unit. - Switch to rotating motor without flying restart function (p1200). Note: Limit current = 2 x minimum (p0640, 4 x p0305 x p0306) >= 2 x p0305 x p0306
<b>Remedy:</b>	- check the current limits (p0640). - vector control: Check the current controller (p1715, p1717). - U/f control: Check the current limiting controller (p1340 ... p1346). - increase the up ramp (p1120) or reduce the load. - check the motor and motor cables for short-circuit and ground fault. - check the motor for the star-delta configuration and rating plate parameterization. - check the power unit and motor combination. - Choose "flying restart" function (p1200) if switched to rotating motor.

---

<b>F07802</b>	<b>Drive: Infeed or power unit not ready</b>
<b>Reaction:</b>	OFF2 (NONE)
<b>Acknowledge:</b>	IMMEDIATELY
<b>Cause:</b>	After an internal switch-on command, the infeed or drive does not signal ready. - monitoring time is too short. - DC link voltage is not present. - associated infeed or drive of the signaling component is defective. - supply voltage incorrectly set.

**Remedy:**

- increase the monitoring time (p0857).
- ensure that there is a DC link voltage. Check the DC link busbar. Enable the infeed.
- replace the associated infeed or drive of the signaling component.
- check the line supply voltage setting (p0210).

See also: p0857 (Power unit monitoring time)

---

**A07805 (N) Drive: Power unit overload I2t**

**Reaction:** NONE

**Acknowledge:** NONE

**Cause:** Alarm threshold for I2t overload (p0294) of the power unit exceeded.  
The response parameterized in p0290 becomes active.  
See also: p0290 (Power unit overload response)

**Remedy:**

- reduce the continuous load.
- adapt the load duty cycle.
- check the assignment of the motor and power unit rated currents.

---

**F07806 Drive: Regenerative power limit exceeded (F3E)**

**Reaction:** OFF2 (IASC/DCBRK)

**Acknowledge:** IMMEDIATELY

**Cause:** For blocksize power units, types PM250 and PM260, the regenerative rated power r0206[2] was exceeded for more than 10 s.  
See also: r0206 (Rated power unit power), p1531 (Power limit regenerative)

**Remedy:**

- increase the down ramp.
- reduce the driving load.
- use a power unit with a higher regenerative feedback capability.
- for vector control, the regenerative power limit in p1531 can be reduced so that the fault is no longer triggered.

---

**F07807 Drive: Short-circuit/ground fault detected**

**Reaction:** OFF2 (NONE)

**Acknowledge:** IMMEDIATELY

**Cause:** A phase-phase short-circuit or ground fault was detected at the motor-side output terminals of the converter.  
Fault value (r0949, interpret decimal):

- 1: Short-circuit, phase UV.
- 2: Short-circuit, phase UW.
- 3: Short-circuit, phase VW.
- 4: Ground fault with overcurrent.

1yxxx: Ground fault with current in phase U detected (y = pulse number, xxxx = component of the current in phase V in per mille).

2yxxx: Ground fault with current in phase V detected (y = pulse number, xxxx = component of the current in phase U in per mille).

**Note:**

Also when interchanging the line and motor cables is identified as a motor-side short circuit.

The ground fault test only functions when the motor is stationary.

Connecting to a motor that is either not de-energized or partially de-energized is possibly detected as ground fault.

9.6 List of fault codes and alarm codes

---

- Remedy:**
- check the motor-side converter connection for a phase-phase short-circuit.
  - rule-out interchanged line and motor cables.
  - check for a ground fault.
- For a ground fault the following applies:
- do not enable the pulses when connecting to a rotating motor without the "Flying restart" function activated (p1200).
  - increase the de-energization time (p0347).
  - increase pulse suppression delay time (p1228) to ensure standstill.
  - if required, deactivate the monitoring (p1901).
- 

**F07810**      **Drive: Power unit EEPROM without rated data**

**Reaction:**      NONE

**Acknowledge:**      IMMEDIATELY

**Cause:**      No rated data are stored in the power unit EEPROM.  
See also: p0205, r0206, r0207, r0208, r0209

**Remedy:**      Replace the power unit or inform Siemens Customer Service.

---

**A07850 (F)**      **External alarm 1**

**Reaction:**      NONE

**Acknowledge:**      NONE

**Cause:**      The condition for "External alarm 1" is satisfied.

**Note:**  
The "External alarm 1" is initiated by a 1/0 edge via binector input p2112.  
See also: p2112 (External alarm 1)

**Remedy:**      Eliminate the causes of this alarm.

---

**A07851 (F)**      **External alarm 2**

**Reaction:**      NONE

**Acknowledge:**      NONE

**Cause:**      The condition for "External alarm 2" is satisfied.

**Note:**  
The "External alarm 2" is initiated by a 1/0 edge via binector input p2116.  
See also: p2116 (External alarm 2)

**Remedy:**      Eliminate the causes of this alarm.

---

**A07852 (F)**      **External alarm 3**

**Reaction:**      NONE

**Acknowledge:**      NONE

**Cause:**      The condition for "External alarm 3" is satisfied.

**Note:**  
The "External alarm 3" is initiated by a 1/0 edge via binector input p2117.  
See also: p2117 (External alarm 3)

**Remedy:**      Eliminate the causes of this alarm.

---

**F07860 (A)**      **External fault 1**

**Reaction:**      OFF2 (IASC/DCBRK, NONE, OFF1, OFF3, STOP2)

**Acknowledge:**      IMMEDIATELY (POWER ON)

---

**Cause:** The condition for "External fault 1" is satisfied.  
**Note:**  
The "External fault 1" is initiated by a 1/0 edge via binector input p2106.  
See also: p2106 (External fault 1)

**Remedy:**

- eliminate the causes of this fault.
- acknowledge fault.

---

**F07861 (A) External fault 2**

**Reaction:** OFF2 (IASC/DCBRK, NONE, OFF1, OFF3, STOP2)

**Acknowledge:** IMMEDIATELY (POWER ON)

**Cause:** The condition for "External fault 2" is satisfied.  
**Note:**  
The "External fault 2" is initiated by a 1/0 edge via binector input p2107.  
See also: p2107 (External fault 2)

**Remedy:**

- eliminate the causes of this fault.
- acknowledge fault.

---

**F07862 (A) External fault 3**

**Reaction:** OFF2 (IASC/DCBRK, NONE, OFF1, OFF3, STOP2)

**Acknowledge:** IMMEDIATELY (POWER ON)

**Cause:** The condition for "External fault 3" is satisfied.  
**Note:**  
The "External fault 3" is initiated by a 1/0 edge via the following parameters.  
- AND logic operation, binector input p2108, p3111, p3112.  
- switch-on delay p3110.  
See also: p2108, p3110, p3111, p3112

**Remedy:**

- eliminate the causes of this fault.
- acknowledge fault.

---

**A07891 Drive: Load monitoring pump/fan blocked**

**Reaction:** NONE

**Acknowledge:** NONE

**Cause:** The load monitoring is configured for a pump or fan (p2193 = 4, 5).  
The monitoring function detects when the pump/fan is blocked.  
It is possible that the blocking torque threshold (p2168) is set too low (e.g. heavy duty starting).  
See also: p2165, p2168, p2181, p2193

**Remedy:**

- check whether the pump/fan is blocked, and if blocked, then resolve the problem.
- check that the fan can freely move, and if necessary, resolve the problem.
- adapt the parameterization corresponding to the load (p2165, p2168)..

---

**A07892 Drive: Load monitoring pump/fan no load condition**

**Reaction:** NONE

**Acknowledge:** NONE

**Cause:** The load monitoring is configured for a pump or fan (p2193 = 4, 5).  
The monitoring function detects when the pump/fan is operating under no load conditions.  
The pump is running in the dry state (no medium to be pumped) – or the fan has a broken belt.  
It is possible that the detection torque threshold is too low (p2191).  
See also: p2181 (Load monitoring response), p2191 (Load monitoring torque threshold no load), p2193 (Load monitoring configuration)

9.6 List of fault codes and alarm codes

---

- Remedy:**
- for a pump, check the medium being pumped, and if required, provide the medium.
  - for a fan, check the belt, and if required, replace.
  - if necessary, increase the detection torque threshold (p2191).

---

**A07893 Drive: Load monitoring pump leakage**

**Reaction:** NONE

**Acknowledge:** NONE

**Cause:** The load monitoring is configured for a pump (p2193 = 4).  
The monitoring function detects a leak in the pump circuit.  
In this case, the pump requires a torque that is lower than in normal operation to pump the reduced quantity.  
See also: p2181, p2182, p2183, p2184, p2186, p2188, p2190, p2193

- Remedy:**
- remove the leak in the pump circuit.
  - for a nuisance trip, reduce the torque thresholds of the leakage characteristic (p2186, p2188, p2190).

---

**F07894 Drive: Load monitoring pump/fan blocked**

**Reaction:** OFF1 (NONE, OFF2, OFF3)

**Acknowledge:** IMMEDIATELY

**Cause:** The load monitoring is configured for a pump or fan (p2193 = 4, 5).  
The monitoring function detects when the pump/fan is blocked.  
It is possible that the blocking torque threshold (p2168) is set too low (e.g. heavy duty starting).  
See also: p2165, p2168, p2181, p2193

- Remedy:**
- check whether the pump/fan is blocked, and if blocked, then resolve the problem.
  - check that the fan can freely move, and if necessary, resolve the problem.
  - adapt the parameterization corresponding to the load (p2165, p2168)..

---

**F07895 Drive: Load monitoring pump/fan no load condition**

**Reaction:** OFF1 (NONE, OFF2, OFF3)

**Acknowledge:** IMMEDIATELY

**Cause:** The load monitoring is configured for a pump or fan (p2193 = 4, 5).  
The monitoring function detects when the pump/fan is operating under no load conditions.  
The pump is running in the dry state (no medium to be pumped) – or the fan has a broken belt.  
It is possible that the detection torque threshold is too low (p2191).  
See also: p2181 (Load monitoring response), p2191 (Load monitoring torque threshold no load), p2193 (Load monitoring configuration)

- Remedy:**
- for a pump, check the medium being pumped, and if required, provide the medium.
  - for a fan, check the belt, and if required, replace.
  - if necessary, increase the detection torque threshold (p2191).

---

**F07896 Drive: Load monitoring pump leakage**

**Reaction:** OFF1 (NONE, OFF2, OFF3)

**Acknowledge:** IMMEDIATELY

**Cause:** The load monitoring is configured for a pump (p2193 = 4).  
The monitoring function detects a leak in the pump circuit.  
In this case, the pump requires a torque that is lower than in normal operation to pump the reduced quantity.  
See also: p2181, p2182, p2183, p2184, p2186, p2188, p2190, p2193

- Remedy:**
- remove the leak in the pump circuit.
  - for a nuisance trip, reduce the torque thresholds of the leakage characteristic (p2186, p2188, p2190).

---

**F07900 (N, A) Drive: Motor blocked**

**Reaction:** OFF2 (NONE, OFF1, OFF3, STOP2)

---

<b>Acknowledge:</b>	IMMEDIATELY
<b>Cause:</b>	<p>Motor has been operating at the torque limit longer than the time specified in p2177 and below the speed threshold in p2175.</p> <p>This signal can also be triggered if the speed is oscillating and the speed controller output repeatedly goes to its limit. It may also be the case that thermal monitoring of the power unit reduces the current limit (see p0290), thereby causing the motor to decelerate.</p> <p>See also: p2175 (Motor blocked speed threshold), p2177 (Motor blocked delay time)</p>
<b>Remedy:</b>	<ul style="list-style-type: none"> <li>- check that the motor can freely move.</li> <li>- check the effective torque limit (r1538, r1539).</li> <li>- check the parameter, message "Motor blocked" and if required, correct (p2175, p2177).</li> <li>- check the direction of rotation enable signals for a flying restart of the motor (p1110, p1111).</li> <li>- for U/f control: check the current limits and acceleration times (p0640, p1120).</li> </ul>

---

<b>F07901</b>	<b>Drive: Motor overspeed</b>
<b>Reaction:</b>	OFF2 (IASC/DCBRK)
<b>Acknowledge:</b>	IMMEDIATELY
<b>Cause:</b>	<p>The maximum permissible speed was either positively or negatively exceeded.</p> <p>The maximum permissible positive speed is formed as follows: Minimum (p1082, Cl: p1085) + p2162</p> <p>The maximum permissible negative speed is formed as follows: Maximum (-p1082, Cl: 1088) - p2162</p>
<b>Remedy:</b>	<p>The following applies for a positive direction of rotation:</p> <ul style="list-style-type: none"> <li>- check r1084 and if required, correct p1082, Cl:p1085 and p2162.</li> </ul> <p>The following applies for a negative direction of rotation:</p> <ul style="list-style-type: none"> <li>- check r1087 and if required, correct p1082, Cl:p1088 and p2162.</li> </ul> <p>Activate precontrol of the speed limiting controller (p1401.7 = 1).</p> <p>Increase the hysteresis for the overspeed signal p2162. This upper limit is dependent upon the maximum motor speed p0322 and the maximum speed p1082 of the setpoint channel.</p>

---

<b>F07902 (N, A)</b>	<b>Drive: Motor stalled</b>
<b>Reaction:</b>	OFF2 (IASC/DCBRK, NONE, OFF1, OFF3, STOP2)
<b>Acknowledge:</b>	IMMEDIATELY
<b>Cause:</b>	<p>The system has identified that the motor has stalled for a time longer than is set in p2178.</p> <p>Fault value (r0949, interpret decimal):</p> <ol style="list-style-type: none"> <li>1: Reserved.</li> <li>2: Stall detection using r1408.12 (p1745) or via (r0084 ... r0083).</li> </ol> <p>See also: p2178 (Motor stalled delay time)</p>
<b>Remedy:</b>	<p>Steps should always be taken to ensure that both motor data identification and the rotating measurement were carried out (see p1900, r3925).</p> <ul style="list-style-type: none"> <li>- check whether the drive stalls solely due to the load in controlled mode or when the speed setpoint is still zero. If yes, then increase the current setpoint using p1610.</li> <li>- if the motor excitation time (p0346) was significantly reduced and the drive stalls when it is switched on and run immediately, p0346 should be increased again.</li> <li>- check whether a line phase failure is affecting power unit PM230, PM250, PM260.</li> <li>- check whether the motor cables are disconnected (see A07929).</li> </ul> <p>If there is no fault, then the fault tolerance (p1745) or the delay time (p2178) can be increased.</p> <ul style="list-style-type: none"> <li>- check the current limits (p0640, r0067, r0289). If the current limits are too low, then the drive cannot be magnetized.</li> <li>- if the fault occurs with fault value 2 when the motor accelerates very quickly to the field weakening range, the deviation between the flux setpoint and flux actual value can be reduced and, in turn, the message prevented, by reducing p1596 or p1553.</li> </ul>

---

<b>A07903</b>	<b>Drive: Motor speed deviation</b>
<b>Reaction:</b>	NONE
<b>Acknowledge:</b>	NONE

9.6 List of fault codes and alarm codes

---

**Cause:** The absolute value of the speed difference from the setpoint (p2151) and the speed actual value (r2169) exceeds the tolerance threshold (p2163) longer than tolerated (p2164, p2166).  
The alarm is only enabled for p2149.0 = 1.  
Possible causes:  
- the load torque is greater than the torque setpoint.  
- when accelerating, the torque/current/power limit is reached. If the limits are not sufficient, then it is possible that the drive has been dimensioned too small.  
- for active Vdc controller.  
For U/f control, the overload condition is detected as the I\_max controller is active.  
See also: p2149 (Monitoring configuration)

**Remedy:**  
- increase p2163 and/or p2166.  
- increase the torque/current/power limits.  
- deactivate alarm with p2149.0 = 0.

---

**A07910 (N) Drive: Motor overtemperature**

**Reaction:** NONE  
**Acknowledge:** NONE  
**Cause:** KTY84/PT1000 or no sensor:  
The measured motor temperature or the temperature of the motor temperature model 2 has exceeded the alarm threshold (p0604). The response parameterized in p0610 becomes active.  
PTC or bimetallic NC contact:  
The response threshold of 1650 Ohm was exceeded or the NC contact opened.  
Alarm value (r2124, interpret decimal):  
11: No output current reduction.  
12: Output current reduction active.  
See also: p0604 (Mot\_temp\_mod 2/sensor alarm threshold), p0610 (Motor overtemperature response)

**Remedy:**  
- check the motor load.  
- check the motor ambient temperature.  
- check KTY84/PT1000.  
- check overtemperatures of the motor temperature model 2 (p0626 ... p0628).  
See also: p0612, p0617, p0618, p0619, p0625, p0626, p0627, p0628

---

**A07920 Drive: Torque/speed too low**

**Reaction:** NONE  
**Acknowledge:** NONE  
**Cause:** For p2193 = 1:  
The torque deviates from the torque/speed envelope characteristic (too low).  
For p2193 = 2:  
The speed signal from the external encoder (refer to p3230) deviates from the speed (r2169) (too low).  
See also: p2181 (Load monitoring response)

**Remedy:**  
- check the connection between the motor and load.  
- adapt the parameterization corresponding to the load.

---

**A07921 Drive: Torque/speed too high**

**Reaction:** NONE  
**Acknowledge:** NONE  
**Cause:** For p2193 = 1:  
The torque deviates from the torque/speed envelope characteristic (too high).  
For p2193 = 2:  
The speed signal from the external encoder (refer to p3230) deviates from the speed (r2169) (too high).



**Remedy:**

- check the connection between the motor and load.
- adapt the parameterization corresponding to the load.

---

**A07922 Drive: Torque/speed out of tolerance**

**Reaction:** NONE

**Acknowledge:** NONE

**Cause:**

For p2193 = 1:  
The torque deviates from the torque/speed envelope characteristic.

For p2193 = 2:  
The speed signal from the external encoder (refer to p3230) deviates from the speed (r2169).

**Remedy:**

- check the connection between the motor and load.
- adapt the parameterization corresponding to the load.

---

**F07923 Drive: Torque/speed too low**

**Reaction:** OFF1 (NONE, OFF2, OFF3)

**Acknowledge:** IMMEDIATELY

**Cause:**

For p2193 = 1:  
The torque deviates from the torque/speed envelope characteristic (too low).

For p2193 = 2:  
The speed signal from the external encoder (refer to p3230) deviates from the speed (r2169) (too low).

**Remedy:**

- check the connection between the motor and load.
- adapt the parameterization corresponding to the load.

---

**F07924 Drive: Torque/speed too high**

**Reaction:** OFF1 (NONE, OFF2, OFF3)

**Acknowledge:** IMMEDIATELY

**Cause:**

For p2193 = 1:  
The torque deviates from the torque/speed envelope characteristic (too high).

For p2193 = 2:  
The speed signal from the external encoder (refer to p3230) deviates from the speed (r2169) (too high).

**Remedy:**

- check the connection between the motor and load.
- adapt the parameterization corresponding to the load.

---

**F07925 Drive: Torque/speed out of tolerance**

**Reaction:** OFF1 (NONE, OFF2, OFF3)

**Acknowledge:** IMMEDIATELY

**Cause:**

For p2193 = 1:  
The torque deviates from the torque/speed envelope characteristic.

For p2193 = 2:  
The speed signal from the external encoder (refer to p3230) deviates from the speed (r2169).

**Remedy:**

- check the connection between the motor and load.
- adapt the parameterization corresponding to the load.

---

**A07926 Drive: Envelope curve parameter invalid**

**Reaction:** NONE

**Acknowledge:** NONE

9.6 List of fault codes and alarm codes

---

**Cause:** Invalid parameter values were entered for the envelope characteristic of the load monitoring.  
The following rules apply for the speed thresholds:  
p2182 < p2183 < p2184  
The following rules apply for the torque thresholds:  
p2185 > p2186  
p2187 > p2188  
p2189 > p2190  
Load monitoring configuration and response must match.  
It is not permissible that the individual load torque monitoring areas overlap.  
Alarm value (r2124, interpret decimal):  
Number of the parameter with the invalid value.  
The load torque monitoring has not been activated as long as the alarm is active.

**Remedy:** - set the parameters for the load monitoring according to the applicable rules.  
- if necessary, deactivate the load monitoring (p2181 = 0, p2193 = 0).

---

**A07927 DC braking active**

**Reaction:** NONE

**Acknowledge:** NONE

**Cause:** The motor is braked with DC current. DC braking is active.

1)

A message with response DCBRK is active. The motor is braked with the braking current set in p1232 for the duration set in p1233. If the standstill threshold p1226 is undershot, then braking is prematurely canceled.

2)

DC braking has been activated at binector input p1230 with the DC braking set (p1230 = 4). Braking current p1232 is injected until this binector input becomes inactive.

**Remedy:** Not necessary.

The alarm automatically disappears once DC braking has been executed.

---

**A07929 (F) Drive: No motor detected**

**Reaction:** NONE

**Acknowledge:** NONE

**Cause:** The absolute current value is so small after enabling the inverter pulses that no motor is detected.

Note:

- in the case of vector control and an induction motor, this alarm is followed by fault F07902.
- PM330: Correction currents are calculated and displayed in the optimized pulse pattern range.

See also: p2179 (Output load identification current limit)

**Remedy:**

- check the motor feeder cables.
  - reduce the threshold value (p2179), e.g. for synchronous motors.
  - increase threshold value (PM330).
  - check the voltage boost of the U/f control (p1310).
  - carry out a standstill measurement to set the stator resistance (p0350).
- 

**F07936 Drive: load failure**

**Reaction:** OFF1 (NONE, OFF2, OFF3)

**Acknowledge:** IMMEDIATELY

**Cause:** The load monitoring has detected a load failure.

**Remedy:**

- check the sensor.
  - if necessary, deactivate the load monitoring (p2193).
- See also: p2193 (Load monitoring configuration), p3232 (Load monitoring failure detection)
-

---

**F07950 (A) Motor parameter incorrect**  
**Reaction:** NONE  
**Acknowledge:** IMMEDIATELY  
**Cause:** The motor parameters were incorrectly entered while commissioning (e.g. p0300 = 0, no motor)  
Fault value (r0949, interpret decimal):  
Parameter number involved.  
See also: p0300, p0301, p0304, p0305, p0307, p0310, p0311, p0314, p0315, p0316, p0320, p0322, p0323  
**Remedy:** Compare the motor data with the rating plate data and if required, correct.

---

**F07967 Drive: Incorrect pole position identification**  
**Reaction:** OFF2 (NONE, OFF1)  
**Acknowledge:** IMMEDIATELY  
**Cause:** A fault has occurred during the pole position identification routine.  
Only for internal Siemens troubleshooting.  
**Remedy:** Carry out a POWER ON.

---

**F07968 Drive: Lq-Ld measurement incorrect**  
**Reaction:** OFF2  
**Acknowledge:** IMMEDIATELY  
**Cause:** A fault has occurred during the Lq-Ld measurement.  
Fault value (r0949, interpret decimal):  
10: Stage 1: The ratio between the measured current and zero current is too low.  
12: Stage 1: The maximum current was exceeded.  
15: Second harmonic too low.  
16: Drive converter too small for the measuring technique.  
17: Abort due to pulse inhibit.  
**Remedy:** For fault value = 10:  
Check whether the motor is correctly connected.  
Replace the power unit involved.  
Deactivate technique (p1909).  
For fault value = 12:  
Check whether motor data have been correctly entered.  
Deactivate technique (p1909).  
For fault value = 16:  
Deactivate technique (p1909).  
For fault value = 17:  
Repeat technique.

---

**F07969 Drive: Incorrect pole position identification**  
**Reaction:** OFF2  
**Acknowledge:** IMMEDIATELY

9.6 List of fault codes and alarm codes

<b>Cause:</b>	<p>A fault has occurred during the pole position identification routine.</p> <p>Fault value (r0949, interpret decimal):</p> <p>1: Current controller limited</p> <p>2: Motor shaft locked.</p> <p>10: Stage 1: The ratio between the measured current and zero current is too low.</p> <p>11: Stage 2: The ratio between the measured current and zero current is too low.</p> <p>12: Stage 1: The maximum current was exceeded.</p> <p>13: Stage 2: The maximum current was exceeded.</p> <p>14: Current difference to determine the +d axis too low.</p> <p>15: Second harmonic too low.</p> <p>16: Drive converter too small for the measuring technique.</p> <p>17: Abort due to pulse inhibit.</p> <p>18: First harmonic too low.</p> <p>20: Pole position identification requested with the motor shaft rotating and activated "flying restart" function.</p>
<b>Remedy:</b>	<p>For fault value = 1:</p> <p>Check whether the motor is correctly connected.</p> <p>Check whether motor data have been correctly entered.</p> <p>Replace the power unit involved.</p> <p>For fault value = 2:</p> <p>Bring the motor into a no-load condition.</p> <p>For fault value = 10:</p> <p>When selecting p1980 = 4: Increase the value for p0325.</p> <p>When selecting p1980 = 1: Increase the value for p0329.</p> <p>Check whether the motor is correctly connected.</p> <p>Replace the power unit involved.</p> <p>For fault value = 11:</p> <p>Increase the value for p0329.</p> <p>Check whether the motor is correctly connected.</p> <p>Replace the power unit involved.</p> <p>For fault value = 12:</p> <p>When selecting p1980 = 4: Reduce the value for p0325.</p> <p>When selecting p1980 = 1: Reduce the value for p0329.</p> <p>Check whether motor data have been correctly entered.</p> <p>For fault value = 13:</p> <p>Reduce the value for p0329.</p> <p>Check whether motor data have been correctly entered.</p> <p>For fault value = 14:</p> <p>Increase the value for p0329.</p> <p>For fault value = 15:</p> <p>Increase the value for p0325.</p> <p>Motor not sufficiently anisotropic, change the technique (p1980 = 1, 10).</p> <p>For fault value = 16:</p> <p>Change the technique (p1980).</p> <p>For fault value = 17:</p> <p>Repeat technique.</p> <p>For fault value = 18:</p> <p>Increase the value for p0329.</p> <p>Saturation not sufficient, change the technique (p1980 = 10).</p> <p>For fault value = 20:</p> <p>Before carrying out a pole position identification routine ensure that the motor shaft is absolutely stationary (zero speed).</p>

---

<b>A07980</b>	<b>Drive: Rotating measurement activated</b>
<b>Reaction:</b>	NONE
<b>Acknowledge:</b>	NONE
<b>Cause:</b>	The rotating measurement (automatic speed controller optimization) is activated. The rotating measurement is carried out at the next switch-on command. Note: During the rotating measurement it is not possible to save the parameters (p0971). See also: p1960 (Rotating measurement selection)
<b>Remedy:</b>	Not necessary. The alarm disappears automatically after the speed controller optimization has been successfully completed or for the setting p1900 = 0.

---

<b>A07981</b>	<b>Drive: Enable signals for the rotating measurement missing</b>
<b>Reaction:</b>	NONE
<b>Acknowledge:</b>	NONE
<b>Cause:</b>	The rotating measurement cannot be started due to missing enable signals. For p1959.13 = 1, the following applies: - enable signals for the ramp-function generator missing (see p1140 ... p1142). - enable signals for the speed controller integrator missing (see p1476, p1477).
<b>Remedy:</b>	- acknowledge faults that are present. - establish missing enable signals. See also: r0002 (Drive operating display), r0046 (Missing enable signal)

---

<b>F07983</b>	<b>Drive: Rotating measurement saturation characteristic</b>
<b>Reaction:</b>	OFF1 (NONE, OFF2)
<b>Acknowledge:</b>	IMMEDIATELY
<b>Cause:</b>	A fault has occurred while determining the saturation characteristic. Fault value (r0949, interpret decimal): 1: The speed did not reach a steady-state condition. 2: The rotor flux did not reach a steady-state condition. 3: The adaptation circuit did not reach a steady-state condition. 4: The adaptation circuit was not enabled. 5: Field weakening active. 6: The speed setpoint was not able to be approached as the minimum limiting is active. 7: The speed setpoint was not able to be approached as the suppression (skip) bandwidth is active. 8: The speed setpoint was not able to be approached as the maximum limiting is active. 9: Several values of the determined saturation characteristic are not plausible. 10: Saturation characteristic could not be sensibly determined because load torque too high.

- Remedy:**
- For fault value = 1:
    - the total drive moment of inertia is far higher than that of the motor (p0341, p0342).
  - De-select rotating measurement (p1960), enter the moment of inertia p0342, re-calculate the speed controller p0340 = 4 and repeat the measurement.
  - For fault value = 1 ... 2:
    - increase the measuring speed (p1961) and repeat the measurement.
  - For fault value = 1 ... 4:
    - check the motor parameters (rating plate data). After the change: Calculate p0340 = 3.
    - check the moment of inertia (p0341, p0342). After the change: Calculate p0340 = 3.
    - carry out a motor data identification routine (p1910).
    - if required, reduce the dynamic factor (p1967 < 25 %).
  - For fault value = 5:
    - the speed setpoint (p1961) is too high. Reduce the speed.
  - For fault value = 6:
    - adapt the speed setpoint (p1961) or minimum limiting (p1080).
  - For fault value = 7:
    - adapt the speed setpoint (p1961) or suppression (skip) bandwidths (p1091 ... p1094, p1101).
  - For fault value = 8:
    - adapt the speed setpoint (p1961) or maximum limit (p1082, p1083 and p1086).
  - For fault value = 9, 10:
    - the measurement was carried out at an operating point where the load torque is too high. Select a more suitable operating point, either by changing the speed setpoint (p1961) or by reducing the load torque. The load torque may not be varied while making measurements.
- Note:
- The saturation characteristic identification routine can be disabled using p1959.1.
- See also: p1959 (Rotating measurement configuration)

---

**F07984 Drive: Speed controller optimization, moment of inertia**

**Reaction:** OFF1 (NONE, OFF2)

**Acknowledge:** IMMEDIATELY

**Cause:** A fault has occurred while identifying the moment of inertia.

Fault value (r0949, interpret decimal):

- 1: The speed did not reach a steady-state condition.
- 2: The speed setpoint was not able to be approached as the minimum limiting is active.
- 3: The speed setpoint was not able to be approached as the suppression (skip) bandwidth is active.
- 4: The speed setpoint was not able to be approached as the maximum limiting is active.
- 5: It is not possible to increase the speed by 10% as the minimum limiting is active.
- 6: It is not possible to increase the speed by 10% as the suppression (skip) bandwidth is active.
- 7: It is not possible to increase the speed by 10% as the maximum limiting is active.
- 8: The torque difference after the speed setpoint step is too low in order to be able to still reliably identify the moment of inertia.
- 9: Too few data to be able to reliably identify the moment of inertia.
- 10: After the setpoint step, the speed either changed too little or in the incorrect direction.
- 11: The identified moment of inertia is not plausible. The measured moment of inertia is less than the 0.1x or greater than 500x the preset moment of inertia of the motor p0341.

<b>Remedy:</b>	<p>For fault value = 1:</p> <ul style="list-style-type: none"> <li>- check the motor parameters (rating plate data). After the change: Calculate p0340 = 3.</li> <li>- check the moment of inertia (p0341, p0342). After the change: Calculate p0340 = 3.</li> <li>- carry out a motor data identification routine (p1910).</li> <li>- if required, reduce the dynamic factor (p1967 &lt; 25 %).</li> </ul> <p>For fault value = 2, 5:</p> <ul style="list-style-type: none"> <li>- adapt the speed setpoint (p1965) or adapt the minimum limit (p1080).</li> </ul> <p>For fault value = 3, 6:</p> <ul style="list-style-type: none"> <li>- adapt the speed setpoint (p1965) or suppression (skip) bandwidths (p1091 ... p1094, p1101).</li> </ul> <p>For fault value = 4, 7:</p> <ul style="list-style-type: none"> <li>- adapt the speed setpoint (p1965) or maximum limit (p1082, p1083 and p1086).</li> </ul> <p>For fault value = 8:</p> <ul style="list-style-type: none"> <li>- the total drive moment of inertia is far higher than that of the motor (refer to p0341, p0342). De-select rotating measurement (p1960), enter the moment of inertia p0342, re-calculate the speed controller p0340 = 4 and repeat the measurement.</li> </ul> <p>For fault value = 9:</p> <ul style="list-style-type: none"> <li>- check the moment of inertia (p0341, p0342). After the change, re-calculate (p0340 = 3 or 4).</li> </ul> <p>For fault value = 10:</p> <ul style="list-style-type: none"> <li>- check the moment of inertia (p0341, p0342). After the change: Calculate p0340 = 3.</li> </ul> <p>For fault value = 11:</p> <ul style="list-style-type: none"> <li>- reduce the moment of inertia of the motor p0341 (e.g. factor of 0.2) or increase (e.g. factor of 5) and repeat the measurement.</li> </ul> <p>Note:</p> <p>The moment of inertia identification routine can be disabled using p1959.2. See also: p1959 (Rotating measurement configuration)</p>
----------------	---

---

<b>F07985</b>	<b>Drive: Speed controller optimization (oscillation test)</b>
<b>Reaction:</b>	OFF1 (NONE, OFF2)
<b>Acknowledge:</b>	IMMEDIATELY
<b>Cause:</b>	<p>A fault has occurred during the vibration test.</p> <p>Fault value (r0949, interpret decimal):</p> <ol style="list-style-type: none"> <li>1: The speed did not reach a steady-state condition.</li> <li>2: The speed setpoint was not able to be approached as the minimum limiting is active.</li> <li>3: The speed setpoint was not able to be approached as the suppression (skip) bandwidth is active.</li> <li>4: The speed setpoint was not able to be approached as the maximum limiting is active.</li> <li>5: Torque limits too low for a torque step.</li> <li>6: No suitable speed controller setting was found.</li> </ol>

9.6 List of fault codes and alarm codes

---

**Remedy:**

For fault value = 1:

- check the motor parameters (rating plate data). After the change: Calculate p0340 = 3.
- check the moment of inertia (p0341, p0342). After the change: Calculate p0340 = 3.
- carry out a motor data identification routine (p1910).
- if required, reduce the dynamic factor (p1967 < 25 %).

For fault value = 2:

- adapt the speed setpoint (p1965) or adapt the minimum limit (p1080).

For fault value = 3:

- adapt the speed setpoint (p1965) or suppression (skip) bandwidths (p1091 ... p1094, p1101).

For fault value = 4:

- adapt the speed setpoint (p1965) or maximum limit (p1082, p1083 and p1086).

For fault value = 5:

- increase the torque limits (e.g. p1520, p1521).

For fault value = 6:

- reduce the dynamic factor (p1967).
- disable the vibration test (p1959.4 = 0) and repeat the rotating measurement.

See also: p1959 (Rotating measurement configuration)

---

**F07986**      **Drive: Rotating measurement ramp-function generator**

**Reaction:**      OFF1 (NONE, OFF2)

**Acknowledge:**      IMMEDIATELY

**Cause:**      During the rotating measurements, problems with the ramp-function generator occurred.  
Fault value (r0949, interpret decimal):  
1: The positive and negative directions are inhibited.

**Remedy:**      For fault value = 1:  
Enable the direction (p1110 or p1111).

---

**F07988**      **Drive: Rotating measurement, no configuration selected**

**Reaction:**      OFF2 (NONE, OFF1)

**Acknowledge:**      IMMEDIATELY

**Cause:**      When configuring the rotating measurement (p1959), no function was selected.

**Remedy:**      Select at least one function for automatic optimization of the speed controller (p1959).  
See also: p1959 (Rotating measurement configuration)

---

**F07990**      **Drive: Incorrect motor data identification**

**Reaction:**      OFF2 (NONE, OFF1)

**Acknowledge:**      IMMEDIATELY



**Cause:** A fault has occurred during the identification routine.  
 Fault value (r0949, interpret decimal):

- 1: Current limit value reached.
- 2: Identified stator resistance lies outside the expected range 0.1 ... 100% of  $Z_n$ .
- 3: Identified rotor resistance lies outside the expected range 0.1 ... 100% of  $Z_n$ .
- 4: identified stator reactance lies outside the expected range 50 ... 500 % of  $Z_n$ .
- 5: identified magnetizing reactance lies outside the expected range 50 ... 500 % of  $Z_n$ .
- 6: Identified rotor time constant lies outside the expected range 10 ms ... 5 s.
- 7: identified total leakage reactance lies outside the expected range 4 ... 50 % of  $Z_n$ .
- 8: Identified stator leakage reactance lies outside the expected range 2 ... 50% of  $Z_n$ .
- 9: Identified rotor leakage reactance lies outside the expected range 2 ... 50% of  $Z_n$ .
- 10: Motor has been incorrectly connected.
- 11: Motor shaft rotates.
- 12: Ground fault detected.
- 15: Pulse inhibit occurred during motor data identification.
- 20: Identified threshold voltage of the semiconductor devices lies outside the expected range 0 ... 10 V.
- 30: Current controller in voltage limiting.
- 40: At least one identification contains errors. The identified parameters are not saved to prevent inconsistencies.
- 60: Incorrect power stack data for the calibration of the converter output voltage
- 61: Incorrect measured values for the calibration of the converter output voltage

**Note:**

Percentage values are referred to the rated motor impedance:

$$Z_n = V_{\text{mot,nom}} / \sqrt{3} / I_{\text{mot,nom}}$$

**Remedy:**

For fault value = 1 ... 40:

- check whether motor data have been correctly entered in p0300, p0304 ... p0311.
- is there an appropriate relationship between the motor power rating and that of the power unit? The ratio of the power unit to the rated motor current should not be less than 0.5 and not be greater than 4.
- check connection type (star-delta).

For fault value = 4, 7:

- check whether the inductance in p0233 is correctly set.
- check whether motor has been correctly connected (star-delta).

For fault value = 11 in addition:

- deactivate oscillation monitoring (p1909.7 = 1).

For fault value = 12:

- check the power cable connections.
- check the motor.
- check the CT.

**A07991 (N) Drive: Motor data identification activated**

**Reaction:** NONE

**Acknowledge:** NONE

**Cause:** The motor data identification routine is activated.

The motor data identification routine is carried out at the next switch-on command.

If rotating measurement is selected (see p1900, p1960), it will not be possible to save the parameter assignment. Once motor data identification has been completed or deactivated, the option to save the parameter assignment will be made available again.

See also: p1910 (Motor data identification selection)

**Remedy:**

Not necessary.

The alarm automatically disappears after the motor data identification routine has been successfully completed or for the setting p1900 = 0.

---

**A07994 (F, N) Drive: motor data identification not performed**

**Reaction:** NONE

**Acknowledge:** NONE

**Cause:** The "Vector control" mode or application class "Standard Drive Control, STC" (p0096 = 1) has been selected, and a motor data identification has still not been performed.

The alarm is initiated when changing the drive data set (see r0051) in the following cases:

- vector control is parameterized in the actual drive data set (p1300 >= 20).

and

- motor data identification has still not been performed in the actual drive data set (see r3925).

**Note:**

For SINAMICS G120, a check is made and the alarm is output also when exiting commissioning and when the system powers up.

**Remedy:**

- Perform motor data identification (see p1900).
- if required, parameterize "U/f control" (p1300 < 20) or set p0096 = 0 (only G120).
- switch over to a drive data set, in which the conditions do not apply.

---

**F08010 (N, A) CU: Analog-to-digital converter**

**Reaction:** OFF1 (IASC/DCBRK, NONE, OFF2, OFF3, STOP2)

**Acknowledge:** IMMEDIATELY (POWER ON)

**Cause:** The analog-to-digital converter on the Control Unit has not supplied any converted data.

**Remedy:**

- check the power supply.
- replace Control Unit.

---

**F08501 (N, A) PROFINET: Setpoint timeout**

**Reaction:** OFF3 (IASC/DCBRK, NONE, OFF1, OFF2, STOP2)

**Acknowledge:** IMMEDIATELY

**Cause:** The reception of setpoints from PROFINET has been interrupted.

- bus connection interrupted.

- controller switched off.

- controller set into the STOP state.

**Remedy:**

- Restore the bus connection and set the controller to RUN.
- if the error is repeated, check the update time set in the bus configuration (HW Config).

---

**F08502 (A) PROFINET: Monitoring time sign-of-life expired**

**Reaction:** OFF1 (OFF2, OFF3)

**Acknowledge:** IMMEDIATELY

**Cause:** The monitoring time for the sign-of-life counter has expired.  
The connection to the PROFINET interface was interrupted.

**Remedy:**

- carry out a POWER ON (switch-off/switch-on).
- contact Technical Support.

---

**A08511 (F) PROFINET: Receive configuration data invalid**

**Reaction:** NONE

**Acknowledge:** NONE

**Cause:** The drive unit did not accept the receive configuration data.

Alarm value (r2124, interpret decimal):

Return value of the receive configuration data check.

2: Too many PZD data words for input or output. The number of possible PZD is specified by the number of indices in r2050/p2051.

3: Uneven number of bytes for input or output.

---

**Remedy:** Check the receive configuration data.  
For alarm value = 2:  
- check the number of data words for output and input.

---

**A08526 (F) PROFINET: No cyclic connection**

**Reaction:** NONE  
**Acknowledge:** NONE  
**Cause:** There is no connection to a PROFINET controller.  
**Remedy:** Establish the cyclic connection and activate the controller with cyclic operation.  
Check the parameters "Name of Station" and "IP of Station" (r61000, r61001).

---

**A08564 PN/COMM BOARD: syntax error in the configuration file**

**Reaction:** NONE  
**Acknowledge:** NONE  
**Cause:** A syntax error has been detected in the ASCII configuration file for the Communication Board Ethernet. The saved configuration file has not been loaded.  
**Remedy:** - correct the PROFINET interface configuration (p8920 and following) and activate (p8925 = 2).  
- reinitialize the station.  
**Note:**  
The configuration is not applied until the next POWER ON!  
See also: p8925 (Activate PN interface configuration)

---

**A08565 PROFINET: Consistency error affecting adjustable parameters**

**Reaction:** NONE  
**Acknowledge:** NONE  
**Cause:** A consistency error was detected when activating the configuration (p8925) for the PROFINET interface. The currently set configuration has not been activated.  
Alarm value (r2124, interpret decimal):  
0: general consistency error  
1: error in the IP configuration (IP address, subnet mask or standard gateway)  
2: Error in the station names.  
3: DHCP was not able to be activated, as a cyclic PROFINET connection already exists.  
4: a cyclic PROFINET connection is not possible as DHCP is activated.  
See also: p8920 (PN Name of Station), p8921 (PN IP address), p8922 (PN Default Gateway), p8923 (PN Subnet Mask)  
**Remedy:** - check the required interface configuration (p8920 and following), correct if necessary, and activate (p8925).  
or  
- reconfigure the station via the "Edit Ethernet node" screen form.  
See also: p8925 (Activate PN interface configuration)

---

**F13009 Licensing OA application not licensed**

**Reaction:** OFF1  
**Acknowledge:** IMMEDIATELY  
**Cause:** At least one OA application which is under license does not have a license.  
**Note:**  
Refer to r4955 and p4955 for information about the installed OA applications.  
**Remedy:** - enter and activate the license key for OA applications under license (p9920, p9921).  
- if necessary, deactivate unlicensed OA applications (p4956).

---

**F13100 Know-how protection: Copy protection error**

**Reaction:** OFF1

9.6 List of fault codes and alarm codes

**Acknowledge:** IMMEDIATELY

**Cause:** The know-how protection with copy protection for the memory card is active.  
An error has occurred when checking the memory card.  
Fault value (r0949, interpret decimal):  
0: A memory card is not inserted.  
1: An invalid memory card is inserted (not SIEMENS).  
2: An invalid memory card is inserted.  
3: The memory card is being used in another Control Unit.  
12: An invalid memory card is inserted (OEM input incorrect, p7769).  
13: The memory card is being used in another Control Unit (OEM input incorrect, p7759).  
See also: p7765 (KHP configuration)

**Remedy:** For fault value = 0, 1:  
- insert the correct memory card and carry out POWER ON.  
For fault value = 2, 3, 12, 13:  
- contact the responsible OEM.  
- Deactivate copy protection (p7765) and acknowledge the fault (p3981).  
- Deactivate know-how protection (p7766 ... p7768) and acknowledge the fault (p3981).  
Note:  
In general, the copy protection can only be changed when know-how protection is deactivated.  
KHP: Know-How Protection  
See also: p3981 (Acknowledge drive object faults), p7765 (KHP configuration)

---

**F13101**      **Know-how protection: Copy protection cannot be activated**

**Reaction:** NONE

**Acknowledge:** IMMEDIATELY

**Cause:** An error occurred when attempting to activate the copy protection for the memory card.  
Fault value (r0949, interpret decimal):  
0: A memory card is not inserted.  
1: An invalid memory card is inserted (not SIEMENS).  
Note:  
KHP: Know-How Protection

**Remedy:** - insert a valid memory card.  
- Try to activate copy protection again (p7765).  
See also: p7765 (KHP configuration)

---

**F13102**      **Know-how protection: Consistency error of the protected data**

**Reaction:** OFF1

**Acknowledge:** IMMEDIATELY

**Cause:** An error was identified when checking the consistency of the protected files. As a consequence, the project on the memory card cannot be run.  
Fault value (r0949, interpret hexadecimal):  
yyyyxxx hex: yyyy = object number, xxx = fault cause  
xxx = 1:  
A file has a checksum error.  
xxx = 2:  
The files are not consistent with one another.  
xxx = 3:  
The project files, which were loaded into the file system via load (download from the memory card), are inconsistent.  
Note:  
KHP: Know-How Protection

---

- Remedy:**
- Replace the project on the memory card or replace project files for download from the memory card.
  - Restore the factory setting and download again.

---

**F30001 Power unit: Overcurrent**

**Reaction:** OFF2

**Acknowledge:** IMMEDIATELY

**Cause:**

The power unit has detected an overcurrent condition.

- closed-loop control is incorrectly parameterized.
- motor has a short-circuit or fault to ground (frame).
- U/f operation: Up ramp set too low.
- U/f operation: rated current of motor much greater than that of power unit.
- High discharge and post-charging current for line supply voltage interruptions.
- High post-charging currents for overload when motoring and DC link voltage dip.
- short-circuit currents at switch-on due to the missing line reactor.
- power cables are not correctly connected.
- power cables exceed the maximum permissible length.
- power unit defective.
- line phase interrupted.

Fault value (r0949, interpret bitwise binary):

Bit 0: Phase U.

Bit 1: Phase V.

Bit 2: Phase W.

Bit 3: Overcurrent in the DC link.

Note:

- Remedy:**
- Fault value = 0 means that the phase with overcurrent is not recognized.
- check the motor data - if required, carry out commissioning.
  - check the motor circuit configuration (star/delta).
  - U/f operation: Increase up ramp.
  - U/f operation: Check assignment of rated currents of motor and power unit.
  - check the line supply quality.
  - reduce motor load.
  - correct connection of line reactor.
  - check the power cable connections.
  - check the power cables for short-circuit or ground fault.
  - check the length of the power cables.
  - replace power unit.
  - check the line supply phases.

---

**F30002 Power unit: DC link voltage overvoltage**

**Reaction:** OFF2

**Acknowledge:** IMMEDIATELY

**Cause:**

The power unit has detected an overvoltage condition in the DC link.

- motor regenerates too much energy.
- line supply voltage too high.
- line phase interrupted.
- DC link voltage control switched off.
- dynamic response of DC link voltage controller excessive or insufficient.

Fault value (r0949, interpret decimal):

DC link voltage at the time of trip [0.1 V].

9.6 List of fault codes and alarm codes

---

**Remedy:**

- increase the ramp-down time (p1121).
- set the rounding times (p1130, p1136). This is particularly recommended in U/f operation to relieve the DC link voltage controller with rapid ramp-down times of the ramp-function generator.
- Activate the DC link voltage controller (p1240, p1280).
- adapt the dynamic response of the DC link voltage controller (p1243, p1247, p1283, p1287).
- check the line supply and DC link voltage. set p0210 as low as possible (also see A07401, p1294 = 0).
- check and correct the phase assignment at the power unit.
- check the line supply phases.

See also: p0210 (Drive unit line supply voltage), p1240 (Vdc controller configuration (vector control))

---

**F30003 Power unit: DC link voltage undervoltage**

**Reaction:** OFF2

**Acknowledge:** IMMEDIATELY

**Cause:** The power unit has detected an undervoltage condition in the DC link.

- line supply failure
- line supply voltage below the permissible value.
- line phase interrupted.

**Note:**

The monitoring threshold for the DC link undervoltage is the minimum of the following values:

- for a calculation, refer to p0210.

**Remedy:**

- check the line supply voltage
- check the line supply phases.

See also: p0210 (Drive unit line supply voltage)

---

**F30004 Power unit: Overtemperature heat sink AC inverter**

**Reaction:** OFF2

**Acknowledge:** IMMEDIATELY

**Cause:** The temperature of the power unit heat sink has exceeded the permissible limit value.

- insufficient cooling, fan failure.
- overload.
- ambient temperature too high.
- pulse frequency too high.

Fault value (r0949, interpret decimal):

Temperature [1 bit = 0.01 °C].

**Remedy:**

- check whether the fan is running.
- check the fan elements.
- check whether the ambient temperature is in the permissible range.
- check the motor load.
- reduce the pulse frequency if this is higher than the rated pulse frequency.

**Notice:**

This fault can only be acknowledged after the alarm threshold for alarm A05000 has been undershot.

See also: p1800 (Pulse frequency setpoint)

---

**F30005 Power unit: Overload I2t**

**Reaction:** OFF2

**Acknowledge:** IMMEDIATELY

**Cause:** The power unit was overloaded (r0036 = 100 %).

- the permissible rated power unit current was exceeded for an inadmissibly long time.
- the permissible load duty cycle was not maintained.

Fault value (r0949, interpret decimal):

I2t [100 % = 16384].

---

- Remedy:**
- reduce the continuous load.
  - adapt the load duty cycle.
  - check the motor and power unit rated currents.
  - reduce the current limit (p0640).
  - during operation with U/f characteristic: reduce the integral time of the current limiting controller (p1341).
- See also: r0036 (Power unit overload I2t), r0206 (Rated power unit power), p0307 (Rated motor power)

---

**F30011 Power unit: Line phase failure in main circuit**

**Reaction:** OFF2 (OFF1)

**Acknowledge:** IMMEDIATELY

**Cause:** At the power unit, the DC link voltage ripple has exceeded the permissible limit value.

Possible causes:

- a line phase has failed.
- the 3 line phases are inadmissibly asymmetrical.
- the capacitance of the DC link capacitor forms a resonance frequency with the line inductance and the reactor integrated in the power unit.
- the fuse of a phase of a main circuit has ruptured.
- a motor phase has failed.

Fault value (r0949, interpret decimal):

Only for internal Siemens troubleshooting.

- Remedy:**
- check the main circuit fuses.
  - check whether a single-phase load is distorting the line voltages.
  - Detune the resonant frequency with the line inductance by using an upstream line reactor.
  - Dampen the resonant frequency with the line inductance by switching over the DC link voltage compensation in the software (see p1810) – or increase the smoothing (see p1806). However, this can have a negative impact on the torque ripple at the motor output.
  - check the motor feeder cables.

---

**F30012 Power unit: Temperature sensor heat sink wire breakage**

**Reaction:** OFF1 (OFF2)

**Acknowledge:** IMMEDIATELY

**Cause:** The connection to a heat sink temperature sensor in the power unit is interrupted.

Fault value (r0949, interpret hexadecimal):

Bit 0: Module slot (electronics slot)

Bit 1: Air intake

Bit 2: Inverter 1

Bit 3: Inverter 2

Bit 4: Inverter 3

Bit 5: Inverter 4

Bit 6: Inverter 5

Bit 7: Inverter 6

Bit 8: Rectifier 1

Bit 9: Rectifier 2

**Remedy:** Contact the manufacturer.

---

**F30013 Power unit: Temperature sensor heat sink short-circuit**

**Reaction:** OFF1 (OFF2)

**Acknowledge:** IMMEDIATELY

9.6 List of fault codes and alarm codes

---

**Cause:** The heat sink temperature sensor in the power unit is short-circuited.

Fault value (r0949, interpret hexadecimal):

Bit 0: Module slot (electronics slot)

Bit 1: Air intake

Bit 2: Inverter 1

Bit 3: Inverter 2

Bit 4: Inverter 3

Bit 5: Inverter 4

Bit 6: Inverter 5

Bit 7: Inverter 6

Bit 8: Rectifier 1

Bit 9: Rectifier 2

**Remedy:** Contact the manufacturer.

---

**F30015 (N, A) Power unit: Phase failure motor cable**

**Reaction:** OFF2 (NONE, OFF1, OFF3)

**Acknowledge:** IMMEDIATELY

**Cause:** A phase failure in the motor feeder cable was detected.

The signal can also be output in the following cases:

- the motor is correctly connected, but the drive has stalled in U/f control. In this case, a current of 0 A is possibly measured in one phase due to asymmetry of the currents.
- the motor is correctly connected, however the closed-speed control is instable and therefore an oscillating torque is generated.

Note:

Chassis power units do not feature phase failure monitoring.

**Remedy:**

- check the motor feeder cables.
- increase the ramp-up or ramp-down time (p1120) if the drive has stalled in U/f control.
- check the speed controller settings.

---

**A30016 (N) Power unit: Load supply switched off**

**Reaction:** NONE

**Acknowledge:** NONE

**Cause:** The DC link voltage is too low.

Alarm value (r2124, interpret decimal):

DC link voltage at the time of trip [0.1 V].

**Remedy:** Under certain circumstances, the AC line supply is not switched on.

---

**F30017 Power unit: Hardware current limit has responded too often**

**Reaction:** OFF2

**Acknowledge:** IMMEDIATELY

**Cause:** The hardware current limitation in the relevant phase (see A30031, A30032, A30033) has responded too often. The number of times the limit has been exceeded depends on the design and type of power unit.

- closed-loop control is incorrectly parameterized.
- fault in the motor or in the power cables.
- the power cables exceed the maximum permissible length.
- motor load too high
- power unit defective.

Fault value (r0949, interpret binary):

Bit 0: Phase U

Bit 1: Phase V

Bit 2: Phase W



- Remedy:**
- check the motor data.
  - check the motor circuit configuration (star-delta).
  - check the motor load.
  - check the power cable connections.
  - check the power cables for short-circuit or ground fault.
  - check the length of the power cables.
  - replace power unit.

---

**F30021 Power unit: Ground fault**

**Reaction:** OFF2

**Acknowledge:** IMMEDIATELY

**Cause:** The power has detected a ground fault.

Possible causes:

- ground fault in the power cables.
- ground fault at the motor.
- CT defective.
- when the brake closes, this causes the hardware DC current monitoring to respond.

Fault value (r0949, interpret decimal):

0:

- the hardware DC current monitoring has responded.

> 0:

Absolute value, summation current [32767 = 271 % rated current].

- Remedy:**
- check the power cable connections.
  - check the motor.
  - check the CT.
  - check the cables and contacts of the brake connection (a wire is possibly broken).
- See also: p0287 (Ground fault monitoring thresholds)

---

**F30022 Power unit: Monitoring U<sub>ce</sub>**

**Reaction:** OFF2

**Acknowledge:** POWER ON

**Cause:** In the power unit, the monitoring of the collector-emitter voltage (U<sub>ce</sub>) of the semiconductor has responded.

Possible causes:

- fiber-optic cable interrupted.
- power supply of the IGBT gating module missing.
- short-circuit at the power unit output.
- defective semiconductor in the power unit.

Fault value (r0949, interpret binary):

Bit 0: Short-circuit in phase U

Bit 1: Short circuit in phase V

Bit 2: Short-circuit in phase W

Bit 3: Light transmitter enable defective

Bit 4: U<sub>ce</sub> group fault signal interrupted

See also: r0949 (Fault value)

- Remedy:**
- check the fiber-optic cable and if required, replace.
  - check the power supply of the IGBT gating module (24 V).
  - check the power cable connections.
  - select the defective semiconductor and replace.

---

**F30024 Power unit: Overtemperature thermal model**

**Reaction:** OFF2

9.6 List of fault codes and alarm codes

**Acknowledge:** IMMEDIATELY  
**Cause:** The temperature difference between the heat sink and chip has exceeded the permissible limit value.  
- the permissible load duty cycle was not maintained.  
- insufficient cooling, fan failure.  
- overload.  
- ambient temperature too high.  
- pulse frequency too high.  
See also: r0037 (Power unit temperatures)  
**Remedy:**  
- adapt the load duty cycle.  
- check whether the fan is running.  
- check the fan elements.  
- check whether the ambient temperature is in the permissible range.  
- check the motor load.  
- reduce the pulse frequency if this is higher than the rated pulse frequency.  
- if DC braking is active: reduce braking current (p1232).

---

**F30025 Power unit: Chip overtemperature**

**Reaction:** OFF2  
**Acknowledge:** IMMEDIATELY  
**Cause:** The chip temperature of the semiconductor has exceeded the permissible limit value.  
- the permissible load duty cycle was not maintained.  
- insufficient cooling, fan failure.  
- overload.  
- ambient temperature too high.  
- pulse frequency too high.  
Fault value (r0949, interpret decimal):  
Temperature difference between the heat sink and chip [0.01 °C].  
**Remedy:**  
- adapt the load duty cycle.  
- check whether the fan is running.  
- check the fan elements.  
- check whether the ambient temperature is in the permissible range.  
- check the motor load.  
- reduce the pulse frequency if this is higher than the rated pulse frequency.  
Notice:  
This fault can only be acknowledged after the alarm threshold for alarm A05001 has been undershot.  
See also: r0037 (Power unit temperatures)

---

**F30027 Power unit: Precharging DC link time monitoring**

**Reaction:** OFF2  
**Acknowledge:** IMMEDIATELY

- Cause:** The power unit DC link was not able to be precharged within the expected time.
- 1) There is no line supply voltage connected.
  - 2) The line contactor/line side switch has not been closed.
  - 3) The line supply voltage is too low.
  - 4) Line supply voltage incorrectly set (p0210).
  - 5) The precharging resistors are overheated as there were too many precharging operations per time unit.
  - 6) The precharging resistors are overheated as the DC link capacitance is too high.
  - 7) The DC link has either a ground fault or a short-circuit.
  - 8) Precharging circuit may be defective.
- Fault value (r0949, interpret binary):  
 yyyyxxxx hex:  
 yyyy = power unit state
- 0: Fault status (wait for OFF and fault acknowledgment).
  - 1: Restart inhibit (wait for OFF).
  - 2: Overvoltage condition detected -> change into the fault state.
  - 3: Undervoltage condition detected -> change into the fault state.
  - 4: Wait for bridging contactor to open -> change into the fault state.
  - 5: Wait for bridging contactor to open -> change into restart inhibit.
  - 6: Commissioning.
  - 7: Ready for precharging.
  - 8: Precharging started, DC link voltage less than the minimum switch-on voltage.
  - 9: Precharging, DC link voltage end of precharging still not detected.
  - 10: Wait for the end of the de-bounce time of the main contactor after precharging has been completed.
  - 11: Precharging completed, ready for pulse enable.
  - 12: Reserved.
- xxxx = Missing internal enable signals, power unit (inverted bit-coded, FFFF hex -> all internal enable signals available)
- Bit 0: Power supply of the IGBT gating shut down.  
 Bit 1: Ground fault detected.  
 Bit 2: Peak current intervention.  
 Bit 3: I2t exceeded.  
 Bit 4: Thermal model overtemperature calculated.  
 Bit 5: (heat sink, gating module, power unit) overtemperature measured.  
 Bit 6: Reserved.  
 Bit 7: Overvoltage detected.  
 Bit 8: Power unit has completed precharging, ready for pulse enable.  
 Bit 9: Reserved.  
 Bit 10: Overcurrent detected.  
 Bit 11: Reserved.  
 Bit 12: Reserved.  
 Bit 13: Vce fault detected, transistor de-saturated due to overcurrent/short-circuit.  
 Bit 14: Undervoltage detected.
- See also: p0210 (Drive unit line supply voltage)

9.6 List of fault codes and alarm codes

---

**Remedy:** In general:

- check the line supply voltage at the input terminals.
- check the line supply voltage setting (p0210).
- wait until the precharging resistors have cooled down. For this purpose, preferably disconnect the infeed unit from the line supply.

For 5):

- carefully observe the permissible precharging frequency (refer to the appropriate Equipment Manual).

For 6):

- check the capacitance of the DC link and, if necessary, reduce it in accordance with the maximum permissible DC link capacitance (see relevant Equipment Manual).

For 7):

- check the DC link for a ground fault or short circuit.

See also: p0210 (Drive unit line supply voltage)

---

**A30030 Power unit: Internal overtemperature alarm**

**Reaction:** NONE

**Acknowledge:** NONE

**Cause:** The temperature inside the drive converter has exceeded the permissible temperature limit.

- insufficient cooling, fan failure.
- overload.
- ambient temperature too high.

Alarm value (r2124, interpret decimal):

Only for internal Siemens troubleshooting.

**Remedy:**

- possibly use an additional fan.
- check whether the ambient temperature is in the permissible range.

Notice:

This fault can only be acknowledged once the permissible temperature limit minus 5 K has been fallen below.

---

**A30031 Power unit: Hardware current limiting in phase U**

**Reaction:** NONE

**Acknowledge:** NONE

**Cause:** Hardware current limit for phase U responded. The pulsing in this phase is inhibited for one pulse period.

- closed-loop control is incorrectly parameterized.
- fault in the motor or in the power cables.
- the power cables exceed the maximum permissible length.
- motor load too high
- power unit defective.

Note:

Alarm A30031 is always output if, for a Power Module, the hardware current limiting of phase U, V or W responds.

**Remedy:**

- check the motor data and if required, recalculate the control parameters (p0340 = 3). As an alternative, run a motor data identification (p1910 = 1, p1960 = 1).
- check the motor circuit configuration (star/delta).
- check the motor load.
- check the power cable connections.
- check the power cables for short-circuit or ground fault.
- check the length of the power cables.

---

**A30032 Power unit: Hardware current limiting in phase V**

**Reaction:** NONE

**Acknowledge:** NONE

---

<b>Cause:</b>	Hardware current limit for phase V responded. The pulsing in this phase is inhibited for one pulse period. <ul style="list-style-type: none"> <li>- closed-loop control is incorrectly parameterized.</li> <li>- fault in the motor or in the power cables.</li> <li>- the power cables exceed the maximum permissible length.</li> <li>- motor load too high</li> <li>- power unit defective.</li> </ul>
	Note: Alarm A30031 is always output if, for a Power Module, the hardware current limiting of phase U, V or W responds.
<b>Remedy:</b>	Check the motor data and if required, recalculate the control parameters (p0340 = 3). As an alternative, run a motor data identification (p1910 = 1, p1960 = 1). <ul style="list-style-type: none"> <li>- check the motor circuit configuration (star/delta).</li> <li>- check the motor load.</li> <li>- check the power cable connections.</li> <li>- check the power cables for short-circuit or ground fault.</li> <li>- check the length of the power cables.</li> </ul>

---

**A30033 Power unit: Hardware current limiting in phase W**

<b>Reaction:</b>	NONE
<b>Acknowledge:</b>	NONE
<b>Cause:</b>	Hardware current limit for phase W responded. The pulsing in this phase is inhibited for one pulse period. <ul style="list-style-type: none"> <li>- closed-loop control is incorrectly parameterized.</li> <li>- fault in the motor or in the power cables.</li> <li>- the power cables exceed the maximum permissible length.</li> <li>- motor load too high</li> <li>- power unit defective.</li> </ul>
	Note: Alarm A30031 is always output if, for a Power Module, the hardware current limiting of phase U, V or W responds.
<b>Remedy:</b>	Check the motor data and if required, recalculate the control parameters (p0340 = 3). As an alternative, run a motor data identification (p1910 = 1, p1960 = 1). <ul style="list-style-type: none"> <li>- check the motor circuit configuration (star/delta).</li> <li>- check the motor load.</li> <li>- check the power cable connections.</li> <li>- check the power cables for short-circuit or ground fault.</li> <li>- check the length of the power cables.</li> </ul>

---

**A30034 Power unit: Internal overtemperature**

<b>Reaction:</b>	NONE
<b>Acknowledge:</b>	NONE
<b>Cause:</b>	The alarm threshold for internal overtemperature has been reached. If the temperature inside the unit continues to increase, fault F30036 may be triggered. <ul style="list-style-type: none"> <li>- ambient temperature might be too high.</li> <li>- insufficient cooling, fan failure.</li> </ul>
	Alarm value (r2124, interpret decimal): Only for internal Siemens troubleshooting.
<b>Remedy:</b>	<ul style="list-style-type: none"> <li>- check the ambient temperature.</li> <li>- check the fan for the inside of the unit.</li> </ul>

---

**F30035 Power unit: Air intake overtemperature**

<b>Reaction:</b>	OFF1 (OFF2)
<b>Acknowledge:</b>	IMMEDIATELY

9.6 List of fault codes and alarm codes

**Cause:** The air intake in the power unit has exceeded the permissible temperature limit.  
For air-cooled power units, the temperature limit is at 55 °C.  
- ambient temperature too high.  
- insufficient cooling, fan failure.  
Fault value (r0949, interpret decimal):  
Temperature [0.01 °C].

**Remedy:** - check whether the fan is running.  
- check the fan elements.  
- check whether the ambient temperature is in the permissible range.

Notice:  
This fault can only be acknowledged after the alarm threshold for alarm A05002 has been undershot.

---

**F30036 Power unit: Internal overtemperature**

**Reaction:** OFF2

**Acknowledge:** IMMEDIATELY

**Cause:** The temperature inside the drive converter has exceeded the permissible temperature limit.  
- insufficient cooling, fan failure.  
- overload.  
- ambient temperature too high.  
Fault value (r0949, interpret decimal):  
Only for internal Siemens troubleshooting.

**Remedy:** - check whether the fan is running.  
- check the fan elements.  
- check whether the ambient temperature is in the permissible range.

Notice:  
This fault can only be acknowledged once the permissible temperature limit minus 5 K has been fallen below.

---

**F30037 Power unit: Rectifier overtemperature**

**Reaction:** OFF2

**Acknowledge:** IMMEDIATELY

**Cause:** The temperature in the rectifier of the power unit has exceeded the permissible temperature limit.  
- insufficient cooling, fan failure.  
- overload.  
- ambient temperature too high.  
- line supply phase failure.  
Fault value (r0949, interpret decimal):  
Temperature [0.01 °C].

**Remedy:** - check whether the fan is running.  
- check the fan elements.  
- check whether the ambient temperature is in the permissible range.  
- check the motor load.  
- check the line supply phases.

Notice:  
This fault can only be acknowledged after the alarm threshold for alarm A05004 has been undershot.

---

**A30042 Power unit: Fan has reached the maximum operating hours**

**Reaction:** NONE

**Acknowledge:** NONE

**Cause:** The maximum operating time of at least one fan will soon be reached, or has already been exceeded.  
 Alarm value (r2124, interpret binary):  
 Bit 0: heat sink fan will reach the maximum operating time in 500 hours.  
 Bit 1: heat sink fan has exceeded the maximum operating time.  
 Bit 8: internal device fan will reach the maximum operating time in 500 hours.  
 Bit 9: internal device fan has exceeded the maximum operating time.  
 Note:  
 The maximum operating time of the heat sink fan in the power unit is displayed in p0252.  
 The maximum operating time of the internal device fan in the power unit is internally specified and is fixed.

**Remedy:** For the fan involved, carry out the following:  
 - replace the fan.  
 - reset the operating hours counter (p0251, p0254).  
 See also: p0251, p0252, p0254

---

**A30049**      **Power unit: Internal fan faulty**  
**Reaction:** NONE  
**Acknowledge:** NONE  
**Cause:** The internal fan has failed.  
**Remedy:** Check the internal fan and replace if necessary.

---

**F30051**      **Power unit: Motor holding brake short circuit detected**  
**Reaction:** OFF2  
**Acknowledge:** IMMEDIATELY  
**Cause:** A short-circuit at the motor holding brake terminals has been detected.  
 Fault value (r0949, interpret decimal):  
 Only for internal Siemens troubleshooting.

**Remedy:** - check the motor holding brake for a short-circuit.  
 - check the connection and cable for the motor holding brake.

---

**F30052**      **EEPROM data error**  
**Reaction:** OFF2  
**Acknowledge:** POWER ON  
**Cause:** EEPROM data error of the power unit module.  
 Fault value (r0949, interpret decimal):  
 0, 2, 3, 4:  
 The EEPROM data read in from the power unit module is inconsistent.  
 1:  
 EEPROM data is not compatible to the firmware of the Control Unit.

**Remedy:** Replace power unit module.

---

**A30057**      **Power unit: Line asymmetry**  
**Reaction:** NONE  
**Acknowledge:** NONE  
**Cause:** Frequencies have been detected on the DC link voltage that would suggest line asymmetry or failure of a line phase.  
 It is also possible that a motor phase has failed.  
 Fault F30011 is output if the alarm is present and at the latest after 5 minutes.  
 The precise duration depends on the power unit type and the particular frequencies. For booksize and chassis power units, the duration also depends on how long the alarm has been active.  
 Alarm value (r2124, interpret decimal):  
 Only for internal Siemens troubleshooting.

9.6 List of fault codes and alarm codes

---

**Remedy:**

- check the line phase connection.
- check the motor feeder cable connections.

If there is no phase failure of the line or motor, then line asymmetry is involved.

- reduce the power in order to avoid fault F30011.

---

**F30059 Power unit: Internal fan faulty**

**Reaction:** OFF2  
**Acknowledge:** IMMEDIATELY  
**Cause:** The internal power unit fan has failed and is possibly defective.  
**Remedy:** Check the internal fan and replace if necessary.

---

**A30065 (F, N) Voltage measured values not plausible**

**Reaction:** NONE  
**Acknowledge:** NONE  
**Cause:** The voltage measurement is not supplying any plausible values  
Alarm value (r2124, interpret bitwise binary):  
Bit 1: Phase U.  
Bit 2: Phase V.  
Bit 3: Phase W.  
**Remedy:**

- Deactivate voltage measurement (p0247.0 = 0).
- Deactivate flying restart with voltage measurement (p0247.5 = 0) and deactivate fast flying restart (p1780.11 = 0).

---

**F30068 Power unit: undertemperature inverter heat sink**

**Reaction:** OFF2  
**Acknowledge:** IMMEDIATELY  
**Cause:** The actual inverter heat sink temperature is below the permissible minimum value.  
Possible causes:

- the power unit is being operated at an ambient temperature that lies below the permissible range.
- the temperature sensor evaluation is defective.

Fault value (r0949, interpret decimal): inverter heat sink temperature [0.1 °C].  
**Remedy:**

- ensure that higher ambient temperatures prevail.
- replace the power unit.

---

**F30071 No new actual values received from the Power Module**

**Reaction:** OFF2  
**Acknowledge:** IMMEDIATELY  
**Cause:** More than one actual value telegram from the power unit module has failed.  
**Remedy:** Check the interface (adjustment and locking) to the power unit module.

---

**F30072 Setpoints can no longer be transferred to the Power Module**

**Reaction:** OFF2  
**Acknowledge:** IMMEDIATELY  
**Cause:** More than one setpoint telegram was not able to be transferred to the power unit module.  
**Remedy:** Check the interface (adjustment and locking) to the power unit module.

---

**F30074 (A) Communication error between the Control Unit and Power Module**

**Reaction:** NONE  
**Acknowledge:** IMMEDIATELY

---



<b>Cause:</b>	<p>Communications between the Control Unit (CU) and Power Module (PM) via the interface no longer possible. The CU may have been withdrawn or is incorrectly inserted.</p> <p>Fault value (r0949, interpret hexadecimal):</p> <p>0 hex:</p> <ul style="list-style-type: none"> <li>- a Control Unit with external 24 V supply was withdrawn from the Power Module during operation.</li> <li>- with the Power Module switched off, the external 24 V supply for the Control Unit was interrupted for some time.</li> </ul> <p>1 hex:</p> <p>The Control Unit was withdrawn from the Power Module during operation, although the encoderless safe motion monitoring functions are enabled. This is not supported. After re-inserting the Control Unit in operation, communications to the Power Module no longer possible.</p> <p>20A hex:</p> <p>The Control Unit was inserted on a Power Module, which has another code number.</p> <p>20B hex:</p> <p>The Control Unit was inserted on a Power Module, which although it has the same code number, has a different serial number. The Control Unit executes an automatic warm restart to accept the new calibration data.</p>
<b>Remedy:</b>	<p>For fault value = 0 and 20A hex:</p> <p>Insert the Control Unit on an appropriate Power Module and continue operation. If required, carry out a POWER ON of the Control Unit.</p> <p>For fault value = 1 hex:</p> <p>Carry out a POWER ON of the Control Unit.</p>

---

### F30075 Configuration of the power unit unsuccessful

<b>Reaction:</b>	OFF2
<b>Acknowledge:</b>	IMMEDIATELY
<b>Cause:</b>	<p>A communication error has occurred while configuring the power unit using the Control Unit. The cause is not clear.</p> <p>Fault value (r0949, interpret decimal):</p> <p>0:</p> <p>The output filter initialization was unsuccessful.</p> <p>1:</p> <p>Activation/deactivation of the regenerative feedback functionality was unsuccessful.</p>
<b>Remedy:</b>	<ul style="list-style-type: none"> <li>- acknowledge the fault and continue operation.</li> <li>- if the fault reoccurs, carry out a POWER ON (switch-off/switch-on).</li> <li>- if required, replace the power unit.</li> </ul>

---

### F30080 Power unit: Current increasing too quickly

<b>Reaction:</b>	OFF2
<b>Acknowledge:</b>	IMMEDIATELY
<b>Cause:</b>	<p>The power unit has detected an excessive rate of rise in the overvoltage range.</p> <ul style="list-style-type: none"> <li>- closed-loop control is incorrectly parameterized.</li> <li>- motor has a short-circuit or fault to ground (frame).</li> <li>- U/f operation: Up ramp set too low.</li> <li>- U/f operation: rated current of motor much greater than that of power unit.</li> <li>- power cables are not correctly connected.</li> <li>- power cables exceed the maximum permissible length.</li> <li>- power unit defective.</li> </ul> <p>Fault value (r0949, interpret bitwise binary):</p> <p>Bit 0: Phase U.</p> <p>Bit 1: Phase V.</p> <p>Bit 2: Phase W.</p>

9.6 List of fault codes and alarm codes

---

- Remedy:**
- check the motor data - if required, carry out commissioning.
  - check the motor circuit configuration (star-delta)
  - U/f operation: Increase up ramp.
  - U/f operation: Check assignment of rated currents of motor and power unit.
  - check the power cable connections.
  - check the power cables for short-circuit or ground fault.
  - check the length of the power cables.
  - replace power unit.

---

**F30081 Power unit: Switching operations too frequent**

**Reaction:** OFF2

**Acknowledge:** IMMEDIATELY

**Cause:** The power unit has executed too many switching operations for current limitation.

- closed-loop control is incorrectly parameterized.
- motor has a short-circuit or fault to ground (frame).
- U/f operation: Up ramp set too low.
- U/f operation: rated current of motor much greater than that of power unit.
- power cables are not correctly connected.
- power cables exceed the maximum permissible length.
- power unit defective.

Fault value (r0949, interpret bitwise binary):

Bit 0: Phase U.

Bit 1: Phase V.

Bit 2: Phase W.

- Remedy:**
- check the motor data - if required, carry out commissioning.
  - check the motor circuit configuration (star-delta)
  - U/f operation: Increase up ramp.
  - U/f operation: Check assignment of rated currents of motor and power unit.
  - check the power cable connections.
  - check the power cables for short-circuit or ground fault.
  - check the length of the power cables.
  - replace power unit.

---

**F30105 PU: Actual value sensing fault**

**Reaction:** OFF2

**Acknowledge:** IMMEDIATELY

**Cause:** At least one incorrect actual value channel was detected on the Power Stack Adapter (PSA).

The incorrect actual value channels are displayed in the following diagnostic parameters.

**Remedy:** Evaluate the diagnostic parameters.

If the actual value channel is incorrect, check the components and if required, replace.

---

**A30502 Power unit: DC link overvoltage**

**Reaction:** NONE

**Acknowledge:** NONE

**Cause:** The power unit has detected overvoltage in the DC link on a pulse inhibit.

- device connection voltage too high.

- line reactor incorrectly dimensioned.

Alarm value (r0949, interpret decimal):

DC link voltage [1 bit = 100 mV].

See also: r0070 (Actual DC link voltage)

**Remedy:**

- check the device supply voltage (p0210).
- check the dimensioning of the line reactor.

See also: p0210 (Drive unit line supply voltage)

---

**F30662 Error in internal communications**

**Reaction:** OFF2  
**Acknowledge:** POWER ON  
**Cause:** A module-internal communication error has occurred.  
Fault value (r0949, interpret hexadecimal):  
Only for internal Siemens troubleshooting.

**Remedy:**

- carry out a POWER ON (switch-off/switch-on).
- upgrade firmware to later version.
- contact Technical Support.

---

**F30664 Error while booting**

**Reaction:** OFF2  
**Acknowledge:** POWER ON  
**Cause:** An error has occurred during booting.  
Fault value (r0949, interpret hexadecimal):  
Only for internal Siemens troubleshooting.

**Remedy:**

- carry out a POWER ON (switch-off/switch-on).
- upgrade firmware to later version.
- contact Technical Support.

---

**N30800 (F) Power unit: Group signal**

**Reaction:** OFF2  
**Acknowledge:** NONE  
**Cause:** The power unit has detected at least one fault.  
**Remedy:** Evaluate the other messages that are presently available.

---

**F30802 Power unit: Time slice overflow**

**Reaction:** OFF2  
**Acknowledge:** IMMEDIATELY  
**Cause:** A time slice overflow has occurred.  
Fault value (r0949, interpret decimal):  
xx: Time slice number xx

**Remedy:**

- carry out a POWER ON (switch-off/switch-on) for all components.
- upgrade firmware to later version.
- contact Technical Support.

---

**F30804 (N, A) Power unit: CRC**

**Reaction:** OFF2 (OFF1, OFF3)  
**Acknowledge:** IMMEDIATELY  
**Cause:** A checksum error (CRC error) has occurred for the power unit.

**Remedy:**

- carry out a POWER ON (switch-off/switch-on) for all components.
- upgrade firmware to later version.
- contact Technical Support.

---

**F30805 Power unit: EEPROM checksum error**

**Reaction:** OFF2  
**Acknowledge:** IMMEDIATELY  
**Cause:** Internal parameter data is corrupted.  
Fault value (r0949, interpret hexadecimal):  
01: EEPROM access error.  
02: Too many blocks in the EEPROM.  
**Remedy:** Replace the module.

---

**F30809 Power unit: Switching information not valid**

**Reaction:** OFF2  
**Acknowledge:** IMMEDIATELY  
**Cause:** For 3P gating unit, the following applies:  
The last switching status word in the setpoint telegram is identified by the end ID. Such an end ID was not found.  
**Remedy:**  
- carry out a POWER ON (switch-off/switch-on) for all components.  
- upgrade firmware to later version.  
- contact Technical Support.

---

**A30810 (F) Power unit: Watchdog timer**

**Reaction:** NONE  
**Acknowledge:** NONE  
**Cause:** When booting it was detected that the cause of the previous reset was an SAC watchdog timer overflow.  
**Remedy:**  
- carry out a POWER ON (switch-off/switch-on) for all components.  
- upgrade firmware to later version.  
- contact Technical Support.

---

**F30850 Power unit: Internal software error**

**Reaction:** OFF1 (NONE, OFF2, OFF3)  
**Acknowledge:** POWER ON  
**Cause:** An internal software error has occurred in the power unit.  
Fault value (r0949, interpret decimal):  
Only for internal Siemens troubleshooting.  
**Remedy:**  
- replace power unit.  
- if required, upgrade the firmware in the power unit.  
- contact Technical Support.

---

**F30903 Power unit: I2C bus error occurred**

**Reaction:** OFF2 (IASC/DCBRK, NONE, OFF1, OFF3, STOP2)  
**Acknowledge:** IMMEDIATELY  
**Cause:** Communications error with an EEPROM or an analog/digital converter.  
Fault value (r0949, interpret hexadecimal):  
80000000 hex:  
- internal software error.  
00000001 hex ... 0000FFFF hex:  
- module fault.  
**Remedy:**  
For fault value = 80000000 hex:  
- upgrade firmware to later version.  
For fault value = 00000001 hex ... 0000FFFF hex:  
- replace the module.

---

**A30920 (F) Temperature sensor fault****Reaction:** NONE**Acknowledge:** NONE**Cause:** When evaluating the temperature sensor, an error occurred.  
Alarm value (r2124, interpret decimal):  
1: Wire breakage or sensor not connected.  
KTY: R > 2120 Ohm, PT1000: R > 2120 Ohm  
2: Measured resistance too low.  
PTC: R < 20 Ohm, KTY: R < 50 Ohm, PT1000: R < 603 Ohm**Remedy:** - make sure that the sensor is connected correctly.  
- replace the sensor.

---

**F30950 Power unit: Internal software error****Reaction:** OFF2**Acknowledge:** POWER ON**Cause:** An internal software error has occurred.  
Fault value (r0949, interpret decimal):  
Information about the fault source.  
Only for internal Siemens troubleshooting.**Remedy:** - if necessary, upgrade the firmware in the power unit to a later version.  
- contact Technical Support.

---

**A30999 (F, N) Power unit: Unknown alarm****Reaction:** NONE**Acknowledge:** NONE**Cause:** An alarm occurred on the power unit that cannot be interpreted by the Control Unit firmware.  
This can occur if the firmware on this component is more recent than the firmware on the Control Unit.  
Alarm value (r2124, interpret decimal):  
Alarm number.  
Note:**Remedy:** If required, the significance of this new alarm can be read about in a more recent description of the Control Unit.  
- replace the firmware on the power unit by an older firmware version (r0128).  
- upgrade the firmware on the Control Unit (r0018).

---

**F35950 TM: Internal software error****Reaction:** OFF2 (NONE)**Acknowledge:** POWER ON**Cause:** An internal software error has occurred.  
Fault value (r0949, interpret decimal):  
Information about the fault source.  
Only for internal Siemens troubleshooting.**Remedy:** - if necessary, upgrade the firmware in the Terminal Module to a later version.  
- contact Technical Support.

---

**A50010 (F) PROFINET: Consistency error affecting adjustable parameters****Reaction:** NONE**Acknowledge:** NONE

9.6 List of fault codes and alarm codes

---

**Cause:** A consistency error was detected when activating the configuration (p8925) for the PROFINET interface. The currently set configuration has not been activated.  
Alarm value (r2124, interpret decimal):  
0: general consistency error  
1: error in the IP configuration (IP address, subnet mask or standard gateway).  
2: Error in the station names.  
3: DHCP was not able to be activated, as a cyclic PROFINET connection already exists.  
4: a cyclic PROFINET connection is not possible as DHCP is activated.  
Note:  
DHCP: Dynamic Host Configuration Protocol  
See also: p8920 (PN Name of Station), p8921 (PN IP address), p8922 (PN Default Gateway), p8923 (PN Subnet Mask), p8924 (PN DHCP Mode)

**Remedy:** - check the required interface configuration (p8920 and following), correct if necessary, and activate (p8925).  
or  
- reconfigure the station via the "Edit Ethernet node" screen form.  
See also: p8925 (Activate PN interface configuration)

---

**A50011 (F) Ethernet/IP: configuration error**

**Reaction:** NONE  
**Acknowledge:** NONE  
**Cause:** An EtherNet/IP controller attempts to establish a connection using an incorrect configuring telegram. The telegram length set in the controller does not match the parameterization in the drive device.  
**Remedy:** Check the set telegram length.  
For p0922 not equal to 999, then the length of the selected telegram applies.  
For p0922 = 999, the maximum interconnected PZD (r2067) applies.  
See also: p0922 (PROFIdrive PZD telegram selection), r2067 (PZD maximum interconnected)

---

**F52960 Cavitation protection failure**

**Reaction:** OFF2  
**Acknowledge:** IMMEDIATELY  
**Cause:** Conditions exist for cavitation damage. Cavitation damage is damage caused to a pump in pumping systems when the fluid is not flowing sufficiently. This can lead to heat build up and subsequent damage to the pump.  
**Remedy:** If cavitation is not occurring, reduce the cavitation threshold p29626, or increase the cavitation protection delay. Ensure sensor feedback is working.

---

**A52961 Cavitation protection warning**

**Reaction:** NONE  
**Acknowledge:** NONE  
**Cause:** Conditions for possible cavitation damage are detected.  
**Remedy:** See F52960.

---

**A52962 Mpc operating time limit exceeded**

**Reaction:** NONE  
**Acknowledge:** NONE  
**Cause:** The continuous operating time of at least one motor has exceeded the limit.  
**Remedy:** Increase p29531 or set p29547 = 0.

---

**A52963 Mpc PID deviation exceeded**

**Reaction:** NONE  
**Acknowledge:** NONE

---

**Cause:** The PID deviation (p2273) has exceeded the threshold (p29544) and all motors are running except the motors under service or locked.

**Remedy:**

- Repair or unlock motors if there are motors under service or locked.
- Add more motors in the system if the number of motors is less than four.

---

**A52964 Mpc one motor available**

**Reaction:** NONE

**Acknowledge:** NONE

**Cause:** Only one motor is not under service or locked manually. All the other motors are under service or locked manually.

**Remedy:** Repair or unlock motors.

---

**F52965 Mpc no motor available**

**Reaction:** OFF2

**Acknowledge:** IMMEDIATELY

**Cause:** All motors are under service or locked manually.

**Remedy:** Repair or unlock (set p29542 = 0) motors.

---

**A52966 Mpc motor quantity not matched**

**Reaction:** NONE

**Acknowledge:** NONE

**Cause:** p29521 and digital output settings do not match.

**Remedy:** Change p29521 or digital output (p0730, p0731, p0732, p0733) settings to ensure that the motor quantity set in p29521 matches with the quantity of digital outputs (mapped in r29529).





 **WARNING**

**Fire or electric shock due to defective components**

If an overcurrent protection device is triggered, the converter may be defective. A defective converter can cause a fire or electric shock.

- Have the converter and the overcurrent protection device checked by a specialist.

## Repair

 **WARNING**

**Fire or electric shock due to improper repair**

Improper repair of the converter may cause malfunctions or result in consequential damage such as fire or electric shock.

- Only commission the following persons to repair the converter:
  - Siemens customer service
  - A repair center that has been authorized by Siemens
  - Specialist personnel who are thoroughly acquainted with all the warnings and operating procedures contained in this manual.
- Only use original spare parts when carrying out repairs.



 **CAUTION**

**Burns due to touching hot surfaces**

Certain components (e.g. the heat sink or line reactor) can become very hot during operation. The components can remain hot for some time after operation. Touching hot surfaces can cause burns to the skin.

- Do not touch hot components during operation or immediately following operation.

## 10.1 Replacing the converter

### 10.1.1 Overview of how to replace a converter

#### Permissible replacement

You must replace the converter if it continually malfunctions.

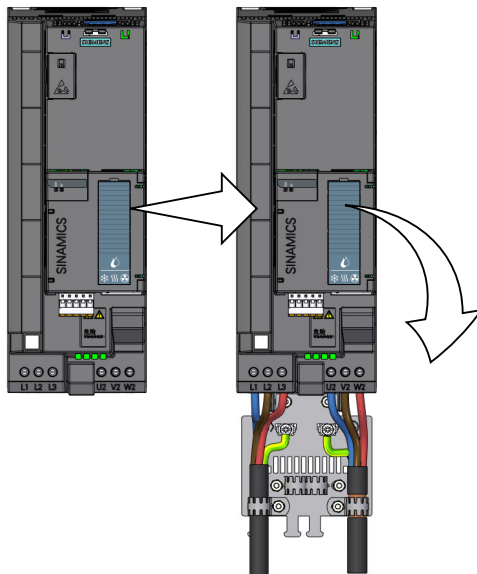

Figure 10-1 Replacing a defective converter

In the following cases you will need to replace the converter:

- The new and replaced converters have the same power rating.
- The new and replaced converters have the same frame size. The new converter has a higher power rating than the converter it replaced.  
In this case, the rated powers of converter and motor must not differ too much:  
Ratio of the rated powers of the motor and the converter  $> 1/4$

#### **! WARNING**

##### **Unexpected machine motion caused by incorrect/inappropriate converter settings**

Replacing converters of different types can result in incomplete or incorrect/inappropriate converter settings. As a consequence, unexpected machine motion, e.g. speed oscillation, overspeed or incorrect direction of rotation. Unexpected machine motion can result in death, injury or material damage.

- In all cases not permitted according to the above description, recommission the drive after replacing a converter.

## 10.1.2 Replacing a converter with data backup

### Replacing a converter with data backup on a memory card

#### Procedure

1. Disconnect the line voltage to the converter.



#### **! WARNING**

##### **Electric shock as a result of a residual charge in power components**

After the power supply has been switched off, it takes up to 5 min. until the capacitors in the converter have discharged so that the residual charge is at a non-hazardous level.

- Check the voltage at the converter connections before you carry out any installation work.

2. Remove the connecting cables of the converter.
3. Remove the defective converter.
4. Install the new converter.
5. Remove the memory card from the old converter
6. Insert the memory card into the new converter.
7. Connect all of the cables to the converter.

#### **NOTICE**

##### **Damage from swapping the motor's connection lines**

The direction in which the motor rotates switches if you exchange the two phases of the motor line.

- Connect the three phases of the motor lines in the right order.
- After replacing the converter, check the direction in which the motor rotates.

8. Reconnect the line voltage to the converter.
9. The converter loads the settings from the memory card.
10. After loading, check whether the converter outputs Alarm A01028.
  - Alarm A01028:  
The loaded settings are not compatible with the converter.  
Clear the alarm with p0971 = 1 and recommission the drive.
  - No alarm A01028:  
The converter has accepted the settings that have been loaded.

You have successfully replaced the converter.



## Replacing a converter with data backup in the Operator Panel

### Precondition

You have backed up the actual settings of the Control Unit to be replaced to an operator panel.

### Procedure

1. Disconnect the line voltage to the converter.



#### **⚠ WARNING**

##### **Electric shock as a result of a residual charge in power components**

After the power supply has been switched off, it takes up to 5 min. until the capacitors in the converter have discharged so that the residual charge is at a non-hazardous level.

- Check the voltage at the converter connections before you carry out any installation work.

2. Remove the connecting cables of the converter.
3. Remove the defective converter.
4. Install the new converter.
5. Connect all of the cables to the converter.
6. Reconnect the line voltage to the converter.
7. Plug the Operator Panel onto the converter or connect the handheld device of the Operator Panel to the converter.
8. Transfer the settings from the operator panel to the converter.
9. Wait until the transfer is complete.
10. After loading, check whether the converter outputs Alarm A01028.
  - Alarm A01028:  
The loaded settings are not compatible with the converter.  
Clear the alarm with p0971 = 1 and recommission the drive.
  - No alarm A01028: Proceed with the next step.
11. Back up the settings so they are not lost when the power fails:
  - For BOP-2 in the menu "EXTRAS" - "RAM-ROM".
  - For IOP-2 in the menu "SAVE RAM TO ROM".

You have replaced the converter and transferred the converter settings from the operator panel to the new converter.

□

### 10.1.3 Replacing a converter without data backup

If the settings have not been backed up, after replacing the converter, you must recommission the drive.

**Procedure**

1. Disconnect the line voltage to the converter.
2. Remove the connecting cables of the converter.
3. Remove the defective converter.
4. Install the new converter.
5. Connect all of the cables to the converter.
6. Switch on the line voltage again.
7. Recommission the drive.

Converter replacement has been completed once it has been commissioned.

□

## 10.2 Replacing spare parts

### 10.2.1 Spare parts compatibility

#### Continuous development within the scope of product maintenance





Converter components are being continuously developed within the scope of product maintenance. Product maintenance includes, for example, measures to increase the ruggedness or hardware changes which become necessary as components are discontinued.





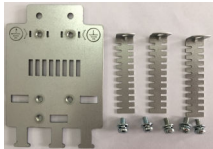

These further developments are "spare parts-compatible" and do not change the article number.

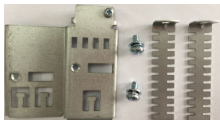
In the scope of such spare parts-compatible ongoing development, plug connector or connection positions are sometimes slightly modified. This does not cause any problems when the components are properly used. Please take this fact into consideration in special installation situations (e.g. allow sufficient reserve regarding the cable length).

### 10.2.2 Spare parts overview

The look of the spare part can differ from the picture.

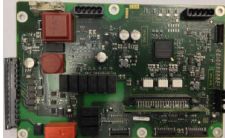
Spare parts		Frame size	Article number
CU spare part kit, consisting of 2 sets of labels, 1 CU door, 1 ESD cover, 2 U clamps, 1 functional grounding clamp, 2 STO connectors, 1 RS485 connector, and 1 set of I/O connectors		FSA ... FSJ	6SL3200-0SK10-0AA0
1 set of small parts for installation		FSD ... FSG	6SL3200-0SK08-0AA0
Shield connection kit for the Power Module		FSA	6SL3262-1AA01-0DA0
		FSB	6SL3262-1AB01-0DA0
		FSC	6SL3262-1AC01-0DA0
		FSD	6SL3262-1AD01-0DA0
		FSE	6SL3262-1AE01-0DA0
		FSF	6SL3262-1AF01-0DA0
		FSG	6SL3262-1AG01-0DA0
Shield connection kit for the Control Unit		FSD ... FSG	6SL3264-1EA00-0YA0

Spare parts		Frame size	Article number
Terminal cover kit		FSD	6SL3200-0SM13-0AA0
		FSE	6SL3200-0SM14-0AA0
		FSF	6SL3200-0SM15-0AA0
		FSG	6SL3200-0SM16-0AA0
External fan unit for the heat sink		FSA	6SL3200-0SF52-0AA0
		FSB	6SL3200-0SF53-0AA0
		FSC	6SL3200-0SF54-0AA0
		FSD	6SL3200-0SF15-0AA0
		FSE	6SL3200-0SF16-0AA0
		FSF	6SL3200-0SF17-0AA0
		FSG	6SL3200-0SF18-0AA0
		FSH/FSJ	6SL3300-0SF01-0AA0
Internal fan unit		FSH/FSJ	6SL3200-0SF50-0AA0
Free programmable interface		FSH/FSJ	6SL3200-0SP05-0AA0
Power supply board		FSH/FSJ	6SL3200-0SP06-0AA0
Current sensor		FSH/FSJ	6SL3200-0SE01-0AA0
		FSJ	6SL3200-0SE02-0AA0

### 10.2.3 Fan units

The average service life of the fan is 40,000 hours. In practice, however, the service life may deviate from this value. Especially a dusty environment can block up the fan. The defective fan must be replaced timely to ensure that the converter is ready for operation.

#### When must the fan unit be replaced?

A defective fan in operation results in an overtemperature condition of the converter. For example, the following messages indicate that the fan unit is defective:

- A05002 (air intake overtemperature)
- A05004 (rectifier overtemperature)
- F30004 (heat sink overtemperature)

- F30024 (temperature model overtemperature)
- F30025 (chip overtemperature)
- F30035 (air intake overtemperature)
- F30037 (rectifier overtemperature)

**Precondition**

Switch off the converter power supply before replacing the fan unit.



 <b>WARNING</b>
<b>Electric shock as a result of a residual charge in power components</b>
After the power supply has been switched off, it takes up to 5 minutes until the capacitors in the converter have discharged so that the residual charge is at a non-hazardous level. Therefore, touching the converter immediately after powering off can result in electric shock due to residual charge in the power components.
<ul style="list-style-type: none"><li>• Check the voltage at the converter connections before you replace the fan unit.</li></ul>



### 10.2.3.1 Replacing the fan unit, FSA ... FSC

The fan unit is installed at the top.

#### Procedure

1. Switch off the converter power supply.
2. For a converter mounted directly on the cabinet panel/mounting plate, skip this step and proceed to Step 3.  
For a push-through mounted converter, you must first remove the top frame by loosening the two screws before replacing the fan unit.

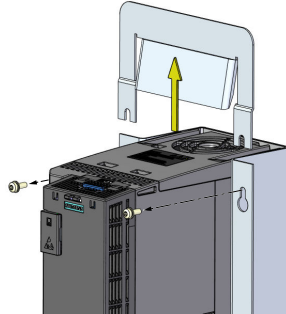

3. Use a screwdriver to remove the fan unit from the converter as shown below.

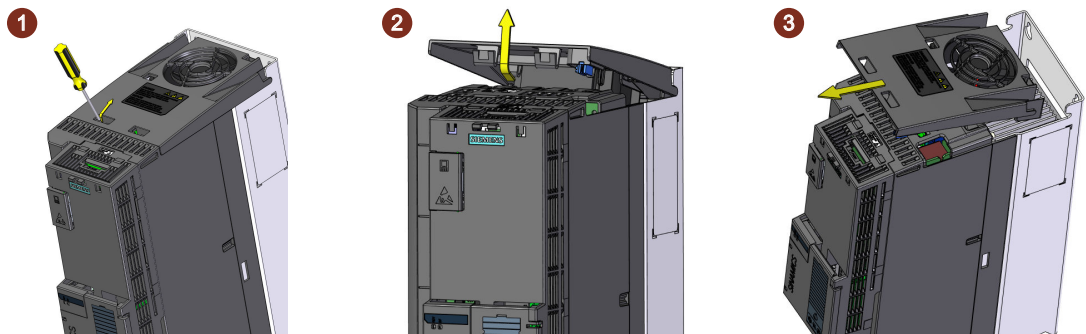

4. Install the new fan unit in the inverse sequence as shown below.

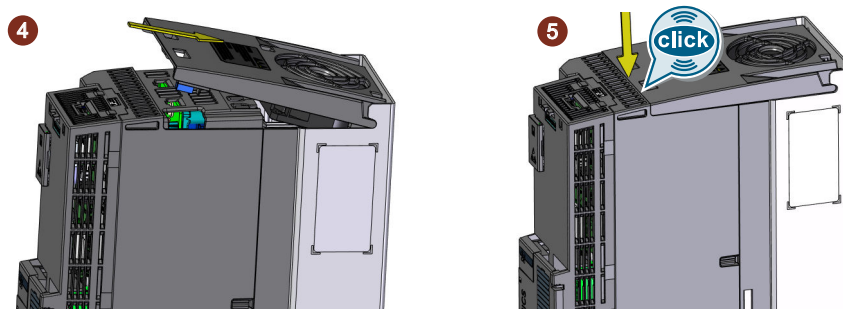

By inserting the fan unit, you have established the electrical connection between the converter and fan unit.

5. For a push-through mounted converter, you must also mount the top push-through mounting frame back.

You have replaced the fan unit.



### 10.2.3.2 Replacing the fan unit, FSD ... FSG

The fan unit is installed at the top.

#### Procedure

1. Switch off the converter power supply.
2. Press the release clips to remove the fan unit from the converter as shown below. Use a screwdriver if necessary.

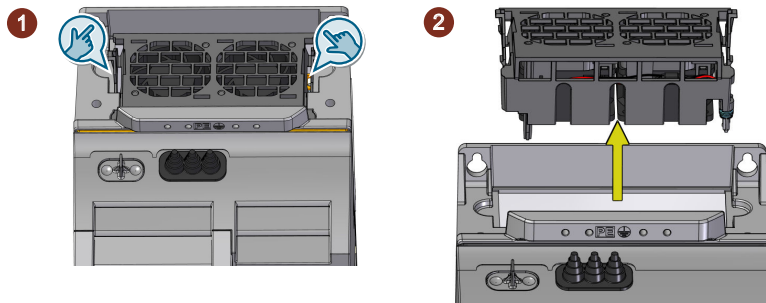

3. Install the new fan unit in the inverse sequence as shown below.

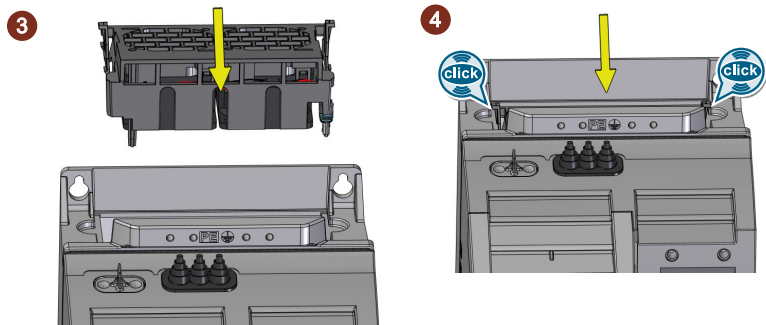

By inserting the fan unit, you have established the electrical connection between the converter and fan unit.

You have replaced the fan unit.



### 10.2.3.3 Replacing the fan unit, FSH/FSJ

Two external fan units are installed at the bottom of the converter.

#### Procedure

1. Switch off the converter power supply.
2. Release the fixing screws from one fan unit using a screwdriver (①). The screws are captive.

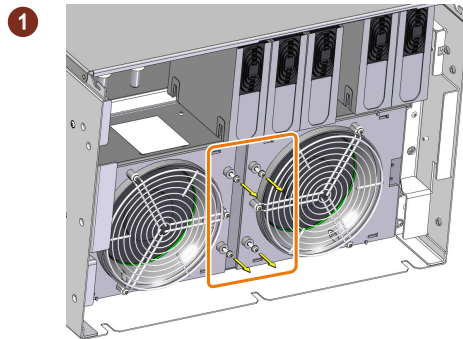

3. Shift this fan unit from position "2" to position "1" (this is marked on the housing) (②). The connector is simultaneously released.

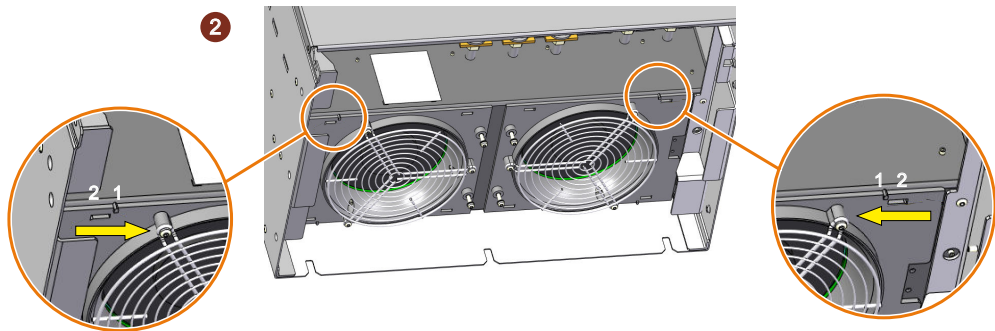

4. Remove the fan unit from the converter (③).

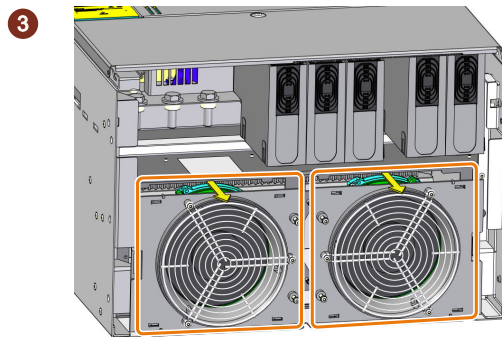

5. Repeat steps 2 to 4 to remove the other fan unit.
6. Install the new fan units in the inverse sequence (tightening torque for the captive fixing screws: 1.8 Nm/15.9 lbf.in).

You have replaced the fan unit.



### 10.2.3.4 Replacing the internal fan, FSH/FSJ only

#### Preconditions

The converter power supply is switched off.

#### Required tools

Torque wrench for TX-25 screws.

#### Function description

##### Removing the fan

1. Remove the screws (TX-25) of the upper and lower terminal cover.
  - FSH: 3 screws
  - FSJ: 4 screws

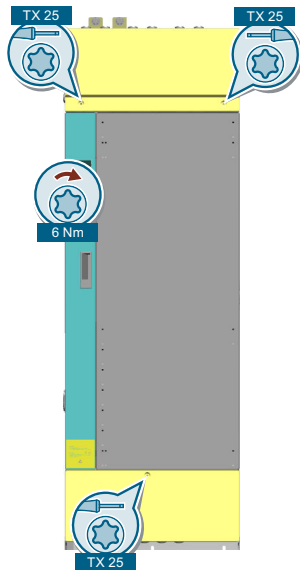

2. Remove the terminal covers.

3. Remove 2 screws (TX-25) of the front cover.

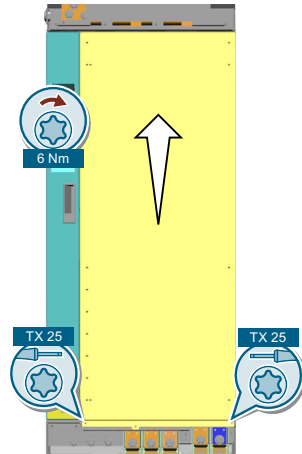

4. Remove the front cover.
5. Remove the fan connector.

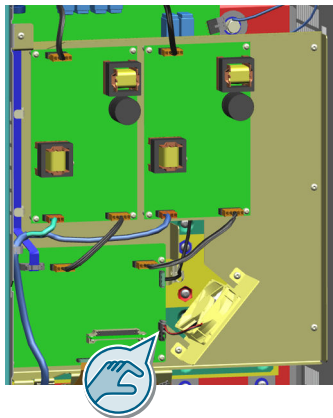

6. Remove 2 screws (TX-25).

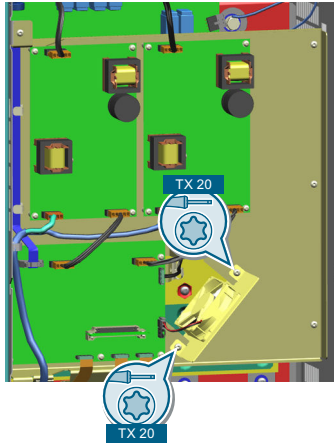

7. Remove the fan.

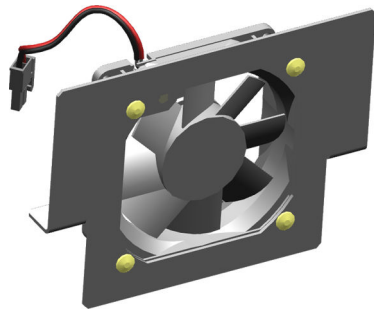

The fan is removed.



#### Installing the fan

1. Mount the fan into the converter.
2. Tighten 2 fan screws (TX-25).
3. Plug the fan connector.
4. Mount the front cover.
5. Tighten 2 screws (TX-25) of the front cover.
6. Mount the terminal covers.
7. Tighten the screws (TX-25) of the upper and lower terminal cover.

The fan is installed.



## 10.2.4 Assemblies for FSH and FSJ

### 10.2.4.1 Replacing the power supply board

#### Precondition

The converter power supply is switched off.

#### Required tools

Torque wrench for the following screws:

- TX-20
- TX-25

#### Function description

##### Removing the power supply board

1. Remove the screws (TX-25) of the upper and lower terminal cover.
  - FSH: 3 screws
  - FSJ: 4 screws

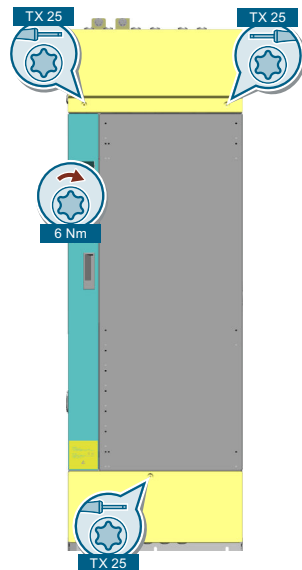

2. Remove the terminal covers.

3. Remove 2 screws (TX-25) of the front cover.

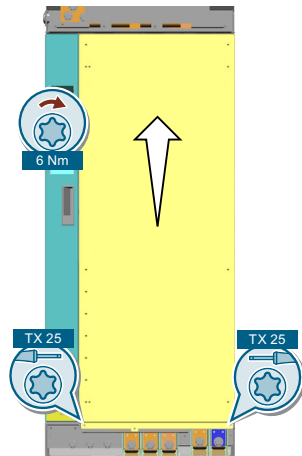

4. Remove the front cover.
5. Remove the connectors on the power supply board.

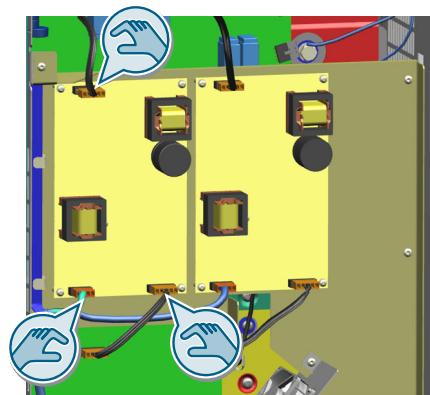

6. Remove 5 screws (TX-20).

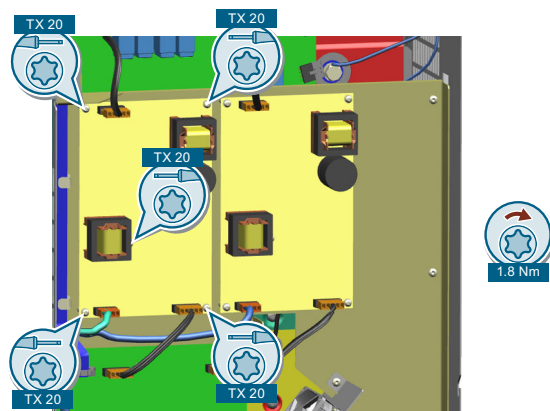

7. Remove the power supply board.  
The power supply board is removed.



**Installing the power supply board**

1. Align the power supply board to the screw holes.
2. Tighten 5 screws (TX-20)
3. Plug the connectors onto the power supply board.
4. Mount the front cover.
5. Tighten 2 screws (TX-25) of the front cover.
6. Mount the terminal covers.
7. Tighten the screws (TX-25) of the upper and lower terminal cover

The power supply board is installed.



### 10.2.4.2 Replacing the free programmable interface (FPI)

#### Precondition

The converter power supply is switched off.

#### Required tools

Torque wrench for the following screws:

- TX-20
- TX-25

#### Function description

##### Removing the FPI board

1. Remove the screws (TX-25) of the upper and lower terminal cover.
  - FSH: 3 screws
  - FSJ: 4 screws

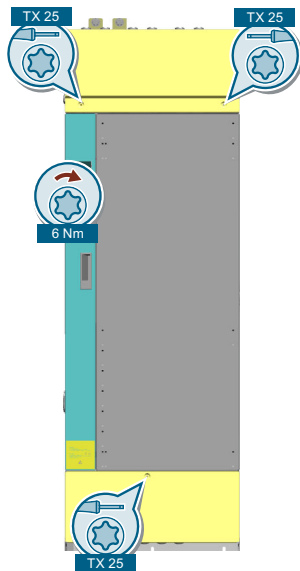

2. Remove the terminal covers.

3. Remove 2 screws (TX-25) of the front cover.

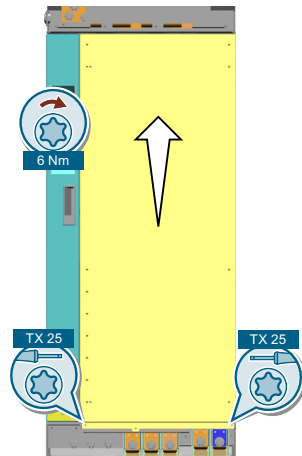

4. Remove the front cover.
5. Remove the connectors on the FPI board.

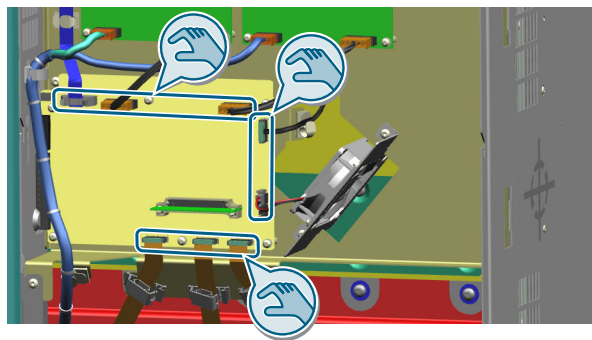

6. Open the locking devices of the IPD.
7. Remove the IPD.

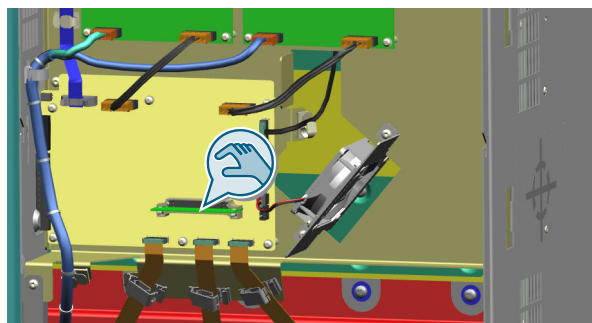

8. Remove the 6 screws on the FPI board (TX-20).



9. Remove the FPI board.

The FPI board is removed.



#### Installing the FPI board

1. Align the FPI board to the screw holes.
2. Insert 6 screws (TX-20)
3. Plug the IPD.
4. Close the locking devices of the IPD.
5. Plug the connectors onto the FPI board.
6. Mount the front cover.
7. Tighten 2 screws (TX-25) of the front cover.
8. Mount the terminal covers.
9. Tighten the screws (TX-25) of the upper and lower terminal cover.

The FPI board is installed.



### 10.2.4.3 Replacing the current sensor

#### Precondition

The converter power supply is switched off.

#### Required tools

Torque wrench for the following screws:

- TX-20
- TX-25
- TX-30

#### Function description

##### Removing the current sensor

1. Remove screws (TX-25) of the upper and lower terminal cover:
  - FSH: 3 screws
  - FSJ: 4 screws

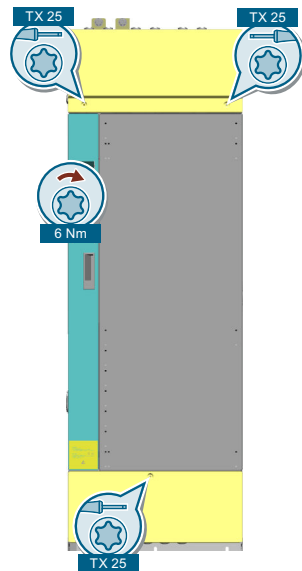

2. Remove the terminal covers.

3. Remove 2 screws (TX-25) of the front cover.

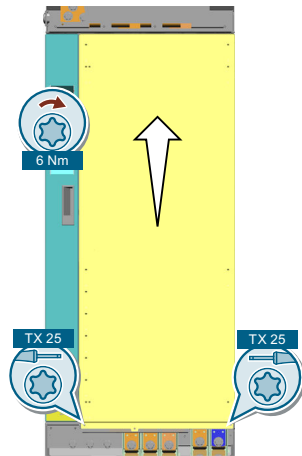

4. Open the front door.
5. Remove the IP20 cover (TX-25).

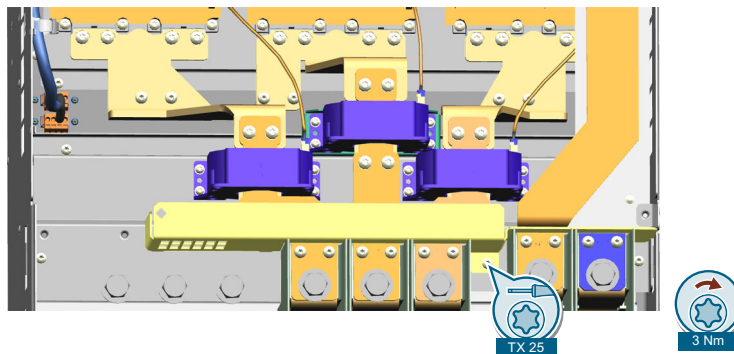

6. Remove the upper copper bar (TX30 and TX-25).

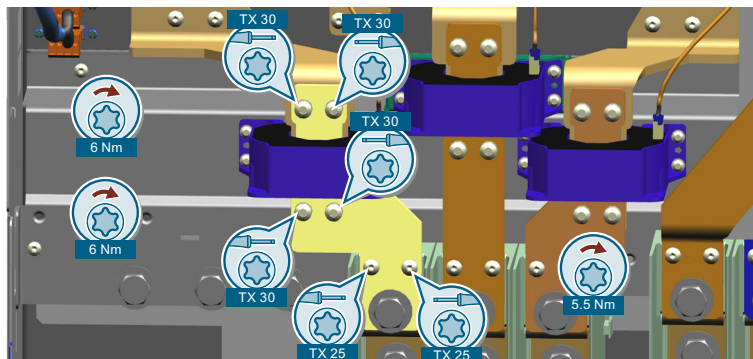

7. Remove the lower copper bar (TX-25).

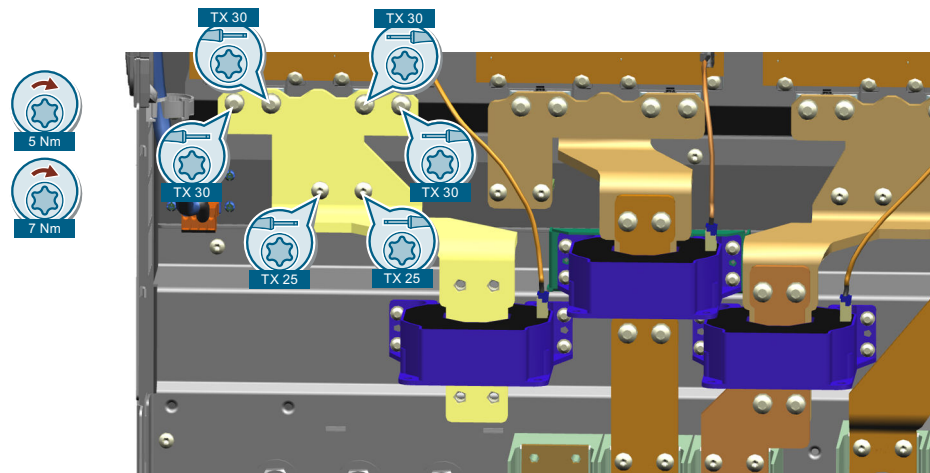

8. Remove the connector of the current sensor.

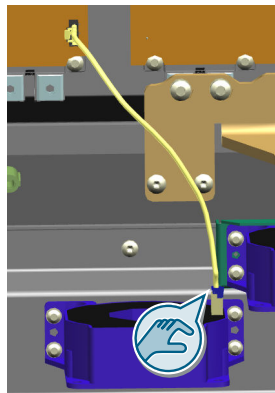

9. Remove the current sensor (TX-20).

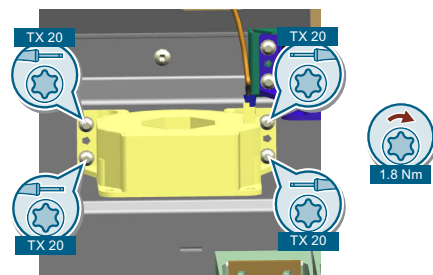

The current sensor is removed.



#### Installing the current sensor

1. Mount the current sensor.
2. Plug the connector of the current sensor.
3. Mount the lower copper bar (TX-25).
4. Mount the upper copper bar (TX30 and TX25).
5. Mount the IP20 cover.

*10.2 Replacing spare parts*

6. Mount the front cover.
7. Tighten 2 screws (TX-25) of the front cover.
8. Mount the terminal covers.
9. Tighten the screws (TX-25) of the upper and lower terminal cover

The current sensor is installed.





## 10.3 Firmware upgrade and downgrade

### Overview

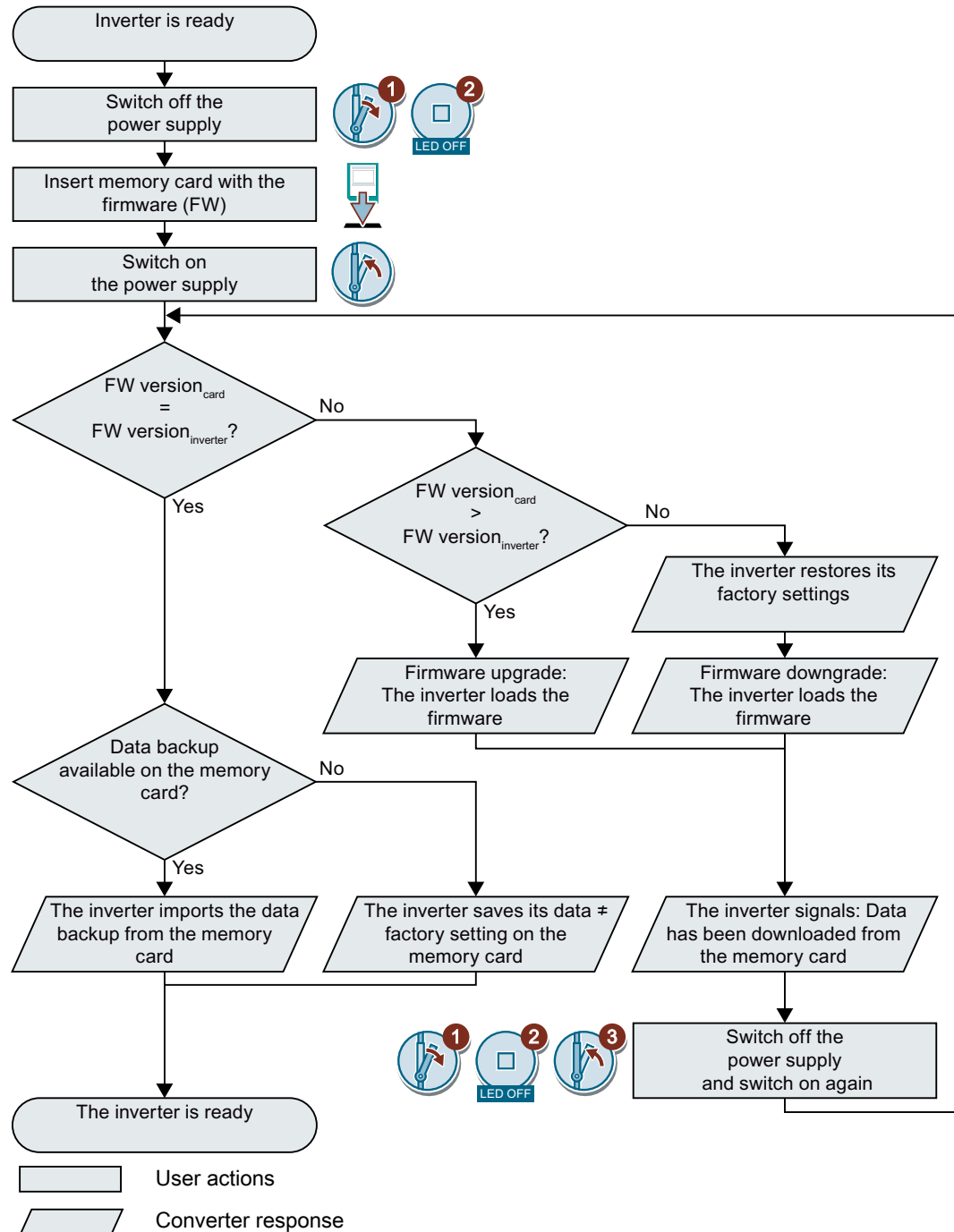

Figure 10-2 Overview of the firmware upgrade and firmware downgrade

### 10.3.1 Preparing the memory card

#### Overview

You can load the converter firmware from the Internet to a memory card.

#### Precondition

You have the appropriate memory card.

 Recommended memory cards (Page 760)

#### Function description

##### Procedure

1. Download the required firmware to your PC from the Internet.  
 Download (<https://support.industry.siemens.com/cs/ww/en/view/67364620>)
2. Extract the files to a directory of your choice on your PC.
3. Transfer the unzipped files into the root directory of the memory card.

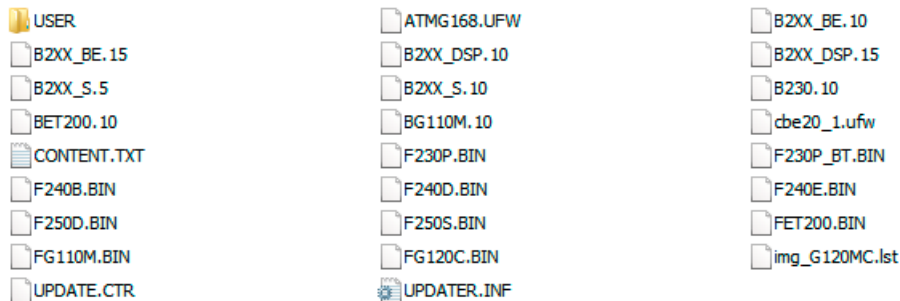

Figure 10-3 Example of memory card contents after the file transfer

Depending on the firmware, the filenames and the number of files may differ from the display above.

The "USER" directory does not exist on unused memory cards. After the memory card is plugged in for the first time, the converter creates a new "USER" directory.

You have prepared the memory card for the firmware upgrade or downgrade.



## 10.3.2 Upgrading the firmware

### Overview

When upgrading the firmware, you replace the converter firmware by a later version.

### Precondition

Converter and memory card have different firmware versions.

### Function description

#### Procedure

1. Switch off the converter power supply.
2. Wait until all LEDs on the converter are dark.
3. Insert the card with the matching firmware into the converter slot until it latches into place.

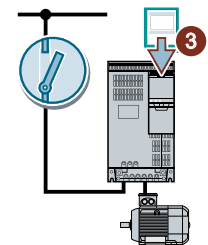
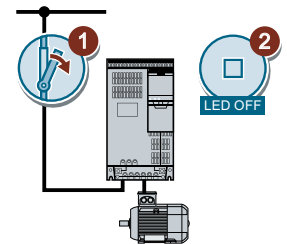

4. Switch on the converter power supply again.
5. The converter transfers the firmware from the memory card into its memory.  
The transfer takes approximately 5 ... 10 minutes.  
While data is being transferred, the LED RDY on the converter stays red. The LED BF flashes orange with a variable frequency.

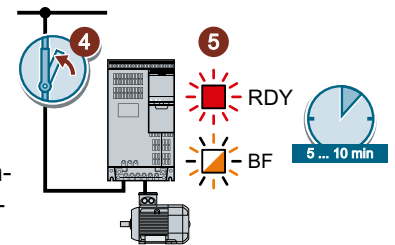

6. At the end of the transfer, the LED RDY and BF slowly flash red (0.5 Hz).

#### Power supply failure during transfer

The converter firmware will be incomplete if the power supply fails during the transfer.

- Start again with step 1 of the instructions.

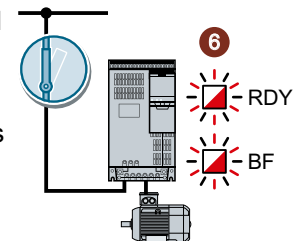

7. Switch off the converter power supply.
8. Wait until all LEDs on the converter are dark.

Decide whether you want to withdraw the memory card from the converter:

- You remove the memory card:  
⇒ The converter keeps its settings.
- You leave the memory card in the converter:  
⇒ If the memory card still does not have a data backup of the converter settings, in step 9 the converter writes its settings to the memory card.  
⇒ If the memory card already includes a data backup, the converter imports the settings from the memory card in step 9.

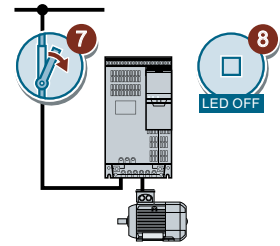

9. Switch on the converter power supply again.
- 10 If the firmware upgrade was successful, after several seconds the converter LED RDY turns green.

If the memory card is still inserted, depending on the previous content of the memory card, one of the two following cases has occurred:

- The memory card contains a data backup:  
⇒ The converter has taken the settings from the memory card.
- There was no data backup on the memory card:  
⇒ The converter has written its settings to the memory card.

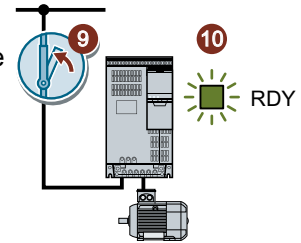

You have upgraded the converter firmware.

□

### 10.3.3 Firmware downgrade

#### Overview

When downgrading the firmware, you replace the converter firmware by an older version.

#### Precondition

- Converter and memory card have different firmware versions.
- The settings have been saved on a memory card or in an operator panel.

#### Function description

##### Procedure

1. Switch off the converter power supply.
2. Wait until all LEDs on the converter are dark.

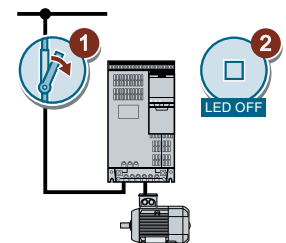

3. Insert the card with the matching firmware into the converter slot until it latches into place.

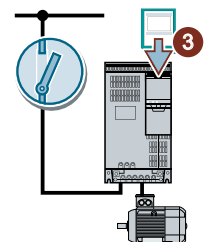

4. Switch on the converter power supply again.
5. The converter transfers the firmware from the memory card into its memory.

The transfer takes approximately 5 ... 10 minutes.

While data is being transferred, the LED RDY on the converter stays red. The LED BF flashes orange with a variable frequency.

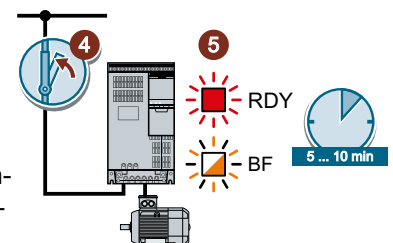

6. At the end of the transfer, the LED RDY and BF slowly flash red (0.5 Hz).

##### Power supply failure during transfer

The converter firmware will be incomplete if the power supply fails during the transfer.

- Start again with Step 1 of these instructions.

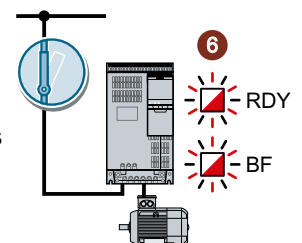

7. Switch off the converter power supply.
8. Wait until all LEDs on the converter are dark.

Decide whether you want to withdraw the memory card from the converter:

- The memory card contains a data backup:  
⇒ The converter has taken the settings from the memory card.
- There was no data backup on the memory card:  
⇒ The converter has the factory setting.

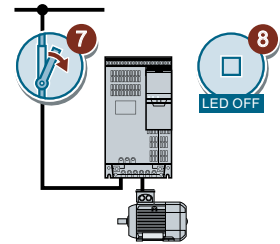

9. Switch on the converter power supply again.
- 10 If the firmware downgrade was successful, after several seconds the converter LED RDY turns green.

If the memory card is still inserted, depending on the previous content of the memory card, one of the two following cases has occurred:

- The memory card contains a data backup:  
⇒ The converter has taken the settings from the memory card.
- There was no data backup on the memory card:  
⇒ The converter has the factory setting.

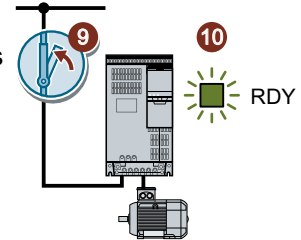

- 11 If the memory card did not contain a data backup of the converter settings, then you must transfer your settings to the converter from another data backup.

 Saving the settings and series commissioning (Page 759)

You have replaced the converter firmware by an older version.

□

### 10.3.4 Correcting an unsuccessful firmware upgrade or downgrade

#### Precondition

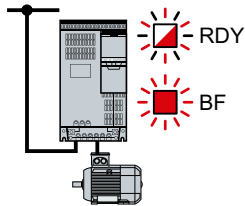

The converter signals an unsuccessful firmware upgrade or downgrade by a quickly flashing LED RDY and the lit LED BF.

#### Function description

You can check the following to correct an unsuccessful firmware upgrade or downgrade:

- Have you correctly inserted the card?
- Does the card contain the correct firmware?

Repeat the firmware upgrade or downgrade

## 10.4 Reduced acceptance test after component replacement and firmware change

After a component has been replaced or the firmware updated, a reduced acceptance test of the safety functions must be performed.

Measure	Reduced acceptance test	
	Acceptance test	Documentation
Replacing the converter with an identical type	No. Only check the direction of rotation of the motor.	<ul style="list-style-type: none"> <li>• Supplement the converter data</li> <li>• Log the new checksums</li> <li>• Countersignature</li> <li>• Supplement the hardware version in the converter data.</li> </ul>
Replacing the motor with an identical pole pair number		No change.
Replace the gearbox with an identical ratio		No change.
Replacing safety-related I/O devices (e.g. Emergency Stop switch).	No. Only check the control of the safety functions affected by the components that have been replaced.	No change.
Converter firmware update.	No.	<ul style="list-style-type: none"> <li>• Supplement firmware version in the converter data</li> <li>• Log the new checksums</li> <li>• Countersignature.</li> </ul>



## Technical data

### 11.1 Technical data of inputs and outputs

Property	Explanation				
Fieldbus interface	With PROFINET interface for the following protocols: <ul style="list-style-type: none"> <li>• PROFINET IO</li> <li>• EtherNet/IP</li> </ul>				
24 V power supply	There are two options regarding the 24 V supply: <ul style="list-style-type: none"> <li>• The converter generates its 24 V power supply from the line voltage.</li> <li>• The converter obtains its 24 V power supply via terminals 31 and 32 with 20.4 ... 28.8 VDC. Current consumption: Maximum 0.5A (The current consumption can be higher if the Control Unit supplies I/O extension module, additional 0.4 A is needed.)</li> </ul>				
Output voltages	<ul style="list-style-type: none"> <li>• 24 V (max. 250 mA)</li> <li>• 10 V (max. 10 mA)</li> </ul>				
Setpoint resolution	0.01 Hz				
Digital inputs	<table border="0"> <tr> <td style="vertical-align: top;">6 (DI 0 ... DI 5)</td> <td> <ul style="list-style-type: none"> <li>• Electrically isolated</li> <li>• Type 3 in accordance with EN 61131-2</li> <li>• Voltage for "low" state: &lt; 5 V</li> <li>• Voltage for "high" state: &gt; 11 V</li> <li>• Current for 24 V input voltage: 4 mA</li> <li>• Minimum current for the "high" state: 2.5 mA</li> <li>• Maximum input voltage: 30 V</li> <li>• PNP/NPN switchable</li> <li>• Compatible to SIMATIC outputs</li> <li>• 10 ms response time for debounce time p0724 = 0</li> </ul> </td> </tr> <tr> <td style="vertical-align: top;">Additional on FSH, FSJ: 4 (DI 0 ... DI 3)</td> <td> <ul style="list-style-type: none"> <li>• Electrically isolated</li> <li>• Type 3 in accordance with EN 61131-2</li> <li>• Voltage for "low" state: &lt; 5 V</li> <li>• Voltage for "high" state: &gt; 15 V</li> <li>• Current for 24 V input voltage: 6.4 mA</li> <li>• Minimum current for the "high" state: 4 mA</li> <li>• Maximum input voltage: 30 V</li> </ul> </td> </tr> </table>	6 (DI 0 ... DI 5)	<ul style="list-style-type: none"> <li>• Electrically isolated</li> <li>• Type 3 in accordance with EN 61131-2</li> <li>• Voltage for "low" state: &lt; 5 V</li> <li>• Voltage for "high" state: &gt; 11 V</li> <li>• Current for 24 V input voltage: 4 mA</li> <li>• Minimum current for the "high" state: 2.5 mA</li> <li>• Maximum input voltage: 30 V</li> <li>• PNP/NPN switchable</li> <li>• Compatible to SIMATIC outputs</li> <li>• 10 ms response time for debounce time p0724 = 0</li> </ul>	Additional on FSH, FSJ: 4 (DI 0 ... DI 3)	<ul style="list-style-type: none"> <li>• Electrically isolated</li> <li>• Type 3 in accordance with EN 61131-2</li> <li>• Voltage for "low" state: &lt; 5 V</li> <li>• Voltage for "high" state: &gt; 15 V</li> <li>• Current for 24 V input voltage: 6.4 mA</li> <li>• Minimum current for the "high" state: 4 mA</li> <li>• Maximum input voltage: 30 V</li> </ul>
6 (DI 0 ... DI 5)	<ul style="list-style-type: none"> <li>• Electrically isolated</li> <li>• Type 3 in accordance with EN 61131-2</li> <li>• Voltage for "low" state: &lt; 5 V</li> <li>• Voltage for "high" state: &gt; 11 V</li> <li>• Current for 24 V input voltage: 4 mA</li> <li>• Minimum current for the "high" state: 2.5 mA</li> <li>• Maximum input voltage: 30 V</li> <li>• PNP/NPN switchable</li> <li>• Compatible to SIMATIC outputs</li> <li>• 10 ms response time for debounce time p0724 = 0</li> </ul>				
Additional on FSH, FSJ: 4 (DI 0 ... DI 3)	<ul style="list-style-type: none"> <li>• Electrically isolated</li> <li>• Type 3 in accordance with EN 61131-2</li> <li>• Voltage for "low" state: &lt; 5 V</li> <li>• Voltage for "high" state: &gt; 15 V</li> <li>• Current for 24 V input voltage: 6.4 mA</li> <li>• Minimum current for the "high" state: 4 mA</li> <li>• Maximum input voltage: 30 V</li> </ul>				

## Technical data

### 11.1 Technical data of inputs and outputs

Property	Explanation	
Failsafe digital input	1 (STO_A, STO_B)	<ul style="list-style-type: none"> <li>Electrically isolated</li> <li>Maximum input voltage: 60 V</li> </ul>
	Only on FSH, FSJ: 1 (STO_A1, STO_A2)	<ul style="list-style-type: none"> <li>Electrically isolated</li> <li>Digital inputs in accordance with EN 61131-2</li> <li>Voltage for "low" state: &lt; 5 V</li> <li>Voltage for "high" state: &gt; 15 V</li> <li>Current for 24 V input voltage: 15 mA</li> <li>Maximum input voltage: 30 V</li> </ul>
Analog inputs	2 (AI 0 ... AI 1)	<ul style="list-style-type: none"> <li>Differential input</li> <li>12-bit resolution</li> <li>13 ms response time</li> <li>Switchable between voltage and current via mechanical switch: <ul style="list-style-type: none"> <li>0 V ... 10 V or -10 V ... +10 V: typical current drain: 0.1 mA, maximum voltage 35 V</li> <li>0 mA ... 20 mA: 120 Ω input resistance, voltage &lt; 10 V, current &lt; 80 mA</li> </ul> </li> <li>If AI 0 and AI 1 are configured as supplementary digital inputs: Voltage &lt; 35 V, low &lt; 1.6 V, high &gt; 4.0 V, 13 ms ± 1 ms response time for debounce time p0724 = 0.</li> </ul>
Digital outputs	2 (DO 0 ... DO 1)	<ul style="list-style-type: none"> <li>DO 0 ... DO 1: 250 V AC 2 A/30 V DC 2 A, for resistive, inductive or capacitive load (For FSB/FSC, the maximum current is 0.5 A to be UL-compliant)</li> <li>Type C relay</li> <li>Update time: 2 ms</li> <li>Overvoltage category: II</li> <li>Switching cycle: 1 Hz</li> </ul>
	Only on FSH, FSJ: 1 (FB_Ax, FB_Bx)	<ul style="list-style-type: none"> <li>30 V DC 0.5 A, for resistive load</li> <li>Overvoltage category: II</li> </ul>
Analog outputs	1 (AO 0)	<ul style="list-style-type: none"> <li>Not isolated</li> <li>16-bit resolution</li> <li>Switchable between voltage and current via parameter setting: <ul style="list-style-type: none"> <li>0 ... 10 V</li> <li>0/4 ... 20 mA</li> </ul> </li> <li>Update time: 4 ms</li> <li>&lt;400 mV offset at 0 %</li> </ul>

Property	Explanation
Motor temperature sensor	PTC <ul style="list-style-type: none"> <li>• Short-circuit monitoring &lt; 20 Ω</li> <li>• Overtemperature 1650 Ω</li> </ul>
	KTY84 <ul style="list-style-type: none"> <li>• Short-circuit monitoring &lt; 50 Ω</li> <li>• Wire-break: &gt; 2120 Ω</li> </ul>
	Pt1000 <ul style="list-style-type: none"> <li>• Short-circuit monitoring &lt; 603 Ω</li> <li>• Wire-break &gt; 2120 Ω</li> </ul>
	Bimetalic temperature switch with NC contact
Memory card (optional)	Slot for SD or MMC memory cards  Recommended memory cards (Page 760)

**Note**

**Short-term voltage dips in the external 24 V supply ( $\leq 3$  ms and  $\leq 95\%$  of the rated voltage)**

When the mains voltage of the converter is switched off, the converter responds to short-term voltage dips in the external 24 V supply with fault F30074. Communication via fieldbus, however, remains in effect in this case.

## 11.2 Load cycles and overload capability

Overload capability is the property of the converter to temporarily supply a current that is higher than the rated current to accelerate a load. Two typical load cycles are defined to clearly demonstrate the overload capability: "Low Overload" and "High Overload".

### Definitions

#### Base load

Constant load between the accelerating phases of the converter

#### Low Overload

- **LO base load input current**  
Permissible input current for a "Low Overload" load cycle
- **LO base load output current**  
Permissible output current for a "Low Overload" load cycle
- **LO base load power**  
Rated power based on the LO base load output current

#### High Overload

- **HO base load input current**  
Permissible input current for a "High Overload" load cycle
- **HO base load output current**  
Permissible output current for a "High Overload" load cycle
- **HO base load power**  
Rated power based on the HO base load output current

If not specified otherwise, the power and current data in the technical data always refer to a load cycle according to Low Overload.

### Load cycles and typical applications

#### "Low Overload" load cycle

The "Low Overload" load cycle assumes a uniform base load with low requirements placed on brief accelerating phases. Typical "Low Overload" applications include the following:

- Centrifuge pump, fan and compressor
- Axial flow fan
- Propeller pump

#### "High Overload" load cycle

The "High Overload" load cycle permits, for reduced base load, dynamic accelerating phases. Typical "High Overload" applications include the following:

- Displacement pump and fan and compressor
- Geared pump
- Screw pump
- Roots blower

### Permissible converter overload

The converter has two different power data: "Low Overload" (LO) and "High Overload" (HO), depending on the expected load.

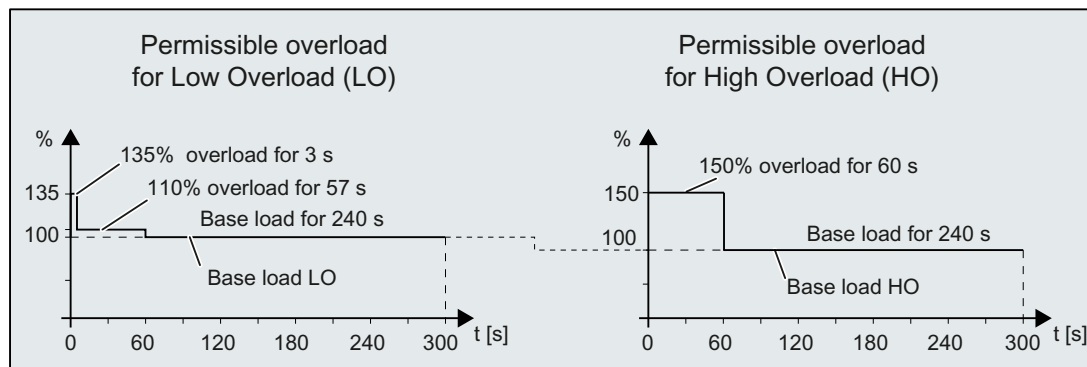

Note that the rated ambient temperature for the above load cycles is 45°C.





#### Note

##### Permissible converter overload for converter FSH/FSJ

When converter FSH/FSJ is operated in low overload, either 135% overload or 110% overload is permissible, but not together.

## 11.3 General converter technical data

Property	Explanation
Line voltage	<p>FSA ... FSG:</p> <ul style="list-style-type: none"> <li>• for systems according to IEC:                             <ul style="list-style-type: none"> <li>– 3 AC 380 V (-20 %) ... 480 V (+10 %)</li> <li>– 3 AC 500 V (-20 %) ... 690 V (+10 %)</li> </ul> </li> <li>• for systems according to UL:                             <ul style="list-style-type: none"> <li>– 3 AC 380 V ... 480 V</li> <li>– 3 AC 500 V ... 600 V</li> </ul> </li> </ul> <p>The actual permissible line voltage depends on the installation altitude.</p> <hr/> <p>FSH, FSJ:</p> <ul style="list-style-type: none"> <li>• 3 AC 380 V (-15 %) ... 480 V (+10 %)</li> <li>• 3 AC 500 V (-15 %) ... 690 V (+10 %)</li> </ul>
Output voltage	0 V 3 AC ... line voltage x 0.97
Input frequency	47 Hz ... 63 Hz
Output frequency	<ul style="list-style-type: none"> <li>• FSA ... FSG: 0 Hz ... 550 Hz, depending on the control mode</li> <li>• FSH/FSJ: 0 Hz ... 150 Hz, depending on the control mode</li> </ul>
Power factor $\lambda$	<ul style="list-style-type: none"> <li>• FSA ... FSG: 0.75 ... 0.93</li> <li>• FSH/FSJ with line reactor <math>u_k = 2\%</math>: 0.75 ... 0.93</li> </ul>
Line impedance $u_k$	4 %
Inrush current	<p><math>&lt; 2 \times</math> peak input current</p> <p>The converter can withstand 100,000 power cycles with an interval of 120 s.</p>
Overvoltage category	<p>According to IEC 61800-5-1:</p> <ul style="list-style-type: none"> <li>• III for Power Module</li> <li>• II for Control Unit</li> </ul>
Line harmonics	<p>The converter fulfils the requirements of IEC 61000-3-12 with <math>R_{sce} = 120</math>.</p> <p>Further technical data on request.</p>
Pulse frequency (factory setting)	<p>FSA ... FSG</p> <ul style="list-style-type: none"> <li>• 400 V converters:                             <ul style="list-style-type: none"> <li>– 4 kHz for devices with an LO base load power <math>&lt; 100</math> kW</li> <li>– 2 kHz for devices with an LO base load power <math>\geq 100</math> kW</li> </ul> </li> <li>• 690 V converters: 2 kHz</li> </ul> <hr/> <p>FSH/FSJ: 4 kHz</p>

Property	Explanation
Safety Integrated	<p>An external safety device is necessary, e. g. F-PLC or Siemens Safety device 3SK2xxx. The higher-level control system must monitor the selection of STO and the feedback from the converter.</p> <p> "Safe Torque Off" safety function (Page 106)</p> <hr/> <p>STO fulfils the requirements of the following standards:</p> <ul style="list-style-type: none"> <li>• SIL 3 according to IEC61508, part 1 to 3 (2010)</li> <li>• PL e according to IEC61800-5-2 (2016)</li> <li>• Category 3 according to ISO13849 part 1 (2015)</li> </ul> <p>The function STO corresponds to stop category 0 according to IEC60204 (2005)</p> <hr/> <p>Response time: 20 ms</p> <p>The response time of the Safe Torque Off function is the time between selecting the function and the function becoming active.</p> <hr/> <p>Probability of failures:</p> <ul style="list-style-type: none"> <li>• Probability of failures per hour: PFH, <math>PFH_D = 5 \times 10^{-8}</math> 1/h PFH according to IEC 61800-5-2, <math>PFH_D</math> according to IEC 62061</li> <li>• Mean probability of failure for a low demand rate of the safety function according to IEC 61508: PFD = <math>5 \times 10^{-3}</math></li> </ul> <hr/> <p>Mission time: 20 years</p> <p>You may not operate converters with integrated safety functions for longer than the mission time. The mission time starts when the device is delivered. The mission time cannot be extended. This is the case even if a service department checks the converter – or in the meantime, the converter was decommissioned.</p>
Degree of protection	<ul style="list-style-type: none"> <li>• IP20/UL Open Type</li> <li>• IP21/UL Open Type can be realized for converters FSA ... FSG, with an IP21 top cover</li> </ul>
Maximum short-circuit current (SCCR or I <sub>cc</sub> )	<p>When using fuses: 100 kA rms</p> <p>You can find the data for further overcurrent protection devices on the Internet:</p> <p> Branch protection and short-circuit strength according to UL and IEC (<a href="https://support.industry.siemens.com/cs/us/en/view/109762895">https://support.industry.siemens.com/cs/us/en/view/109762895</a>)</p>
Minimum short-circuit current	<p>18 kA rms</p> <p>The length of the connecting cable from the line to the converter may not reduce the minimum short-circuit current.</p>
Surrounding air temperature during operation	<ul style="list-style-type: none"> <li>• FSA ... FSG: -20 °C to +55 °C (with a lateral clearance of 5 cm) or -20 °C to +50 °C (without lateral clearance), &gt; 45 °C with derating With operator panel BOP-2 or IOP-2: 0 °C to +50 °C</li> <li>• FSH/FSJ: 0 °C to 55 °C, &gt; 45 °C with derating With operator panel BOP-2 or IOP-2: 0 °C to +50 °C</li> </ul> <p> Current derating as a function of the ambient temperature (Page 908)</p>
Relative humidity	< 95% (non-condensing)
Installation altitude	<p>Up to 1000 m above sea level without derating</p> <p>Above 1000 m with derating</p> <p> Current derating as a function of the installation altitude (Page 907)</p>
Surrounding air temperature during storage	<ul style="list-style-type: none"> <li>• FSA ... FSG: -40 °C to +70 °C</li> <li>• FSH/FSJ: -25 °C to +55 °C -40 °C for maximal 24 h</li> </ul>

11.3 General converter technical data

Property	Explanation
Shock and vibration	<ul style="list-style-type: none"> <li>• FSA ... FSG                             <ul style="list-style-type: none"> <li>– Transport in transportation packaging according to Class 2M3 according to EN 61800-5-1 and EN 60068-2-6</li> <li>– Vibration in operation according to Class 3M1 according to EN 60721-3-3: 1995</li> </ul> </li> <li>• FSH/FSJ                             <ul style="list-style-type: none"> <li>– Vibration during operation: Fc test according to EN 60068-2-6 0.075 mm for 10 ... 58 Hz 9.81 m/s<sup>2</sup> (1 x g) at &gt; 58 ... 200 Hz</li> <li>– Shock during operation: Test according to EN 60068- 2-27 (EA shock type) 49 m/s<sup>2</sup> (5 x g)/30 ms 147 m/s<sup>2</sup> (15 x g)/11 ms</li> <li>– Vibration during product packaging: Fc test according to EN 60068-2-6 ±1.5 mm for 5 ... 9 Hz 0.5 g at 9 ... 200 Hz</li> <li>– Shock during product packaging: Fc test according to EN 60068-2-6 ±1.5 mm for 5 ... 9 Hz 0.5 g at 9 ... 200 Hz</li> </ul> </li> </ul>
Protection against chemical substances	Protected according to 3C2 to EN 60721-3-3
Pollution	Suitable for environments with degree of pollution 2 according to EN 61800-5-1
Sound pressure level LPA (1 m)	≤ 74 dB (A) <sup>1)</sup>
Cooling method	Air forced cooling
Cooling air	Clean and dry air

<sup>1)</sup> Maximum sound pressure level, ascertained in the IP20 cabinet



## 11.4 Technical data dependent on the power

### FSA, 3-phase 380 ... 480 VAC

FSA					
Based on low overload					
• Power (kW)	0.75	1.1	1.5	2.2	3
• Power (hp)	1	1.5	2	3	4
• Input current (A) at 400 V, 45°C	2.1	2.8	3.6	5.5	6.9
• Input current (A) at 480 V, 45°C	2.0	2.7	3.0	4.6	5.8
• Output current (A) at 400 V, 45°C	2.2	3.1	4.1	5.9	7.7
• Output current (A) at 480 V, 45°C	2.1	3.0	3.4	4.8	6.2
Based on high overload					
• Power (kW)	0.55	0.75	1.1	1.5	2.2
• Power (hp)	0.75	1	1.5	2	3
• Input current (A) at 400 V, 45°C	1.7	2.1	2.8	3.6	5.5
• Input current (A) at 480 V, 45°C	1.6	2.0	2.7	3.0	4.6
• Output current (A) at 400 V, 45°C	1.7	2.2	3.1	4.1	5.9
• Output current (A) at 480 V, 45°C	1.6	2.1	3.0	3.4	4.8
Power loss (kW)					
• Without filter	0.043	0.055	0.071	0.090	0.123
• With filter	0.043	0.055	0.072	0.091	0.125
Net weight (kg)					
• Without filter	3.3	3.3	3.3	3.4	3.4
• With filter	3.5	3.5	3.5	3.6	3.6

### FSB/FSC, 3-phase 380 ... 480 VAC

	FSB			FSC	
Based on low overload					
• Power (kW)	4	5.5	7.5	11	15
• Power (hp)	5	7.5	10	15	20
• Input current (A) at 400 V, 45°C	9.75	12	17	24.5	29.5
• Output current (A) at 400 V, 45°C	10.2	13.2	18	26	32
• Output current (A) at 480 V, 45°C	7.6	11	14	21	27
Based on high overload					
• Power (kW)	3	4	5.5	7.5	11
• Power (hp)	4	5	7.5	10	15
• Input current (A) at 400 V, 45°C	7.75	9.75	13.25	18.25	24.5
• Output current (A) at 400 V, 45°C	7.7	10.2	13.2	18	26

Technical data

11.4 Technical data dependent on the power

	FSB			FSC	
• Output current (A) at 480 V, 45°C	6.2	7.6	11	14	21
Power loss (kW)					
• Without filter	0.136	0.18	0.245	0.316	0.396
• With filter	0.138	0.183	0.253	0.32	0.402
Net weight (kg)					
• Without filter	5.8	5.8	5.8	7.1	7.1
• With filter	6.2	6.2	6.2	7.7	7.7

FSD ... FSG, 3-phase 380 ... 480 VAC

Frame size	Rated power - kW(hp)	Rated input current - kW-A (hp - A)	Rated output current - kW - A (hp - A)	Power - kW(hp)	Input current - kW - A (hp - A)	Output current - kW -A (hp - A)	Power loss (kW)		Net weight (kg)	
							Without filter	With filter	Without filter	With filter
Based on Low Overload				Based on High Overload			Without filter	With filter	Without filter	With filter
FSD	18.5 (25)	36 (32)	38 (34)	15 (20)	33 (28)	32 (27)	0.59	0.60	16.6	18.3
	22 (30)	42 (37)	45 (40)	18.5 (25)	38 (35)	38 (34)	0.72	0.73	16.6	18.3
	30 (40)	57 (49)	60 (52)	22 (30)	47 (41)	45 (40)	0.83	0.84	16.6	18.3
	37 (50)	70 (61)	75 (65)	30 (40)	62 (54)	60 (52)	1.10	1.11	18.8	19.5
FSE	45 (60)	86 (74)	90 (77)	37 (50)	78 (69)	75 (65)	1.33	1.34	17.6	18.3
	55 (75)	104 (91)	110 (96)	45 (60)	94 (80)	90 (77)	1.73	1.71	26.7	28.7
FSF	75 (100)	140 (120)	145 (124)	55 (75)	117 (102)	110 (96)	1.97	2.00	61	67.5
	90 (125)	172 (151)	178 (156)	75 (100)	154 (132)	145 (124)	2.57	2.61	61	67.5
	110 (150)	198 (174)	205 (180)	90 (125)	189 (166)	178 (156)	2.37	2.41	66.5	71
	132 (200)	241 (232)	250 (240)	110 (150)	218 (191)	205 (180)	3.10	3.16	66.5	71
FSG	160 (200)	301 (301)	302 (302)	132 (200)	275 (263)	250 (240)	3.22 *	3.66 **	--	105
	200 (250)	365 (356)	370 (361)	160 (250)	330 (327)	302 (302)	4.61 *	4.61 **	--	113
	250 (300)	471 (471)	477 (477)	200 (300)	400 (392)	370 (361)	6.17 *	6.17 **	--	120
FSH	315 (400)	585 (486)	570 (477)	250 (300)	477 (397)	468 (390)	--	6.79	--	151
	355 (450)	654 (525)	640 (515)	250 (300)	501 (402)	491 (394)	--	7.69	--	157
	400 (500)	735 (602)	720 (590)	315 (350)	562 (461)	551 (452)	--	8.39	--	159
FSJ	450 (500)	850 (687)	820 (663)	355 (450)	696 (561)	672 (542)	--	10.42	--	235
	500 (600)	924 (751)	890 (724)	400 (500)	756 (614)	728 (591)	--	10.89	--	250
	560 (700)	1038 (862)	1000 (830)	450 (500)	816 (677)	786 (652)	--	12.50	--	250

\* With C3 filter

\*\* With C2 filter

11.4 Technical data dependent on the power

3-phase 500 ... 690 VAC \*

Frame size	Rated power - kW (hp)	Rated input current - kW - A (hp - A)	Rated output current kW - A (hp - A)	Power - kW (hp)	Input current - kW - A (hp - A)	Output current - kW - A (hp - A)	Power loss (kW)		Weight (kg)	
							Without filter	With filter	Without filter	With filter
FSD	3 (3)	5 (5)	5 (5)	2.2 (3)	4.4 (4.4)	4 (4)	0.16	0.16	16.6	18.3
	4 (5)	6 (6)	6.3 (6.3)	3 (4)	5.2 (5.2)	5 (5)	0.19	0.19	16.6	18.3
	5.5 (7.5)	9 (9)	9 (9)	4 (5)	6.9 (6.9)	6.3 (6.3)	0.26	0.26	16.6	18.3
	7.5 (10)	11 (11)	11 (11)	5.5 (7.5)	9.9 (9.9)	9 (9)	0.31	0.31	16.6	18.3
	11 (n/a)	14 (14)	14 (14)	7.5 (10)	12.1 (12.1)	11 (11)	0.36	0.36	16.6	18.3
	15 (15)	18 (18)	19 (19)	11 (n/a)	14.6 (14.6)	14 (14)	0.45	0.45	16.6	18.3
	18.5 (20)	22 (22)	23 (23)	15 (15)	20 (20)	19 (19)	0.53	0.54	16.6	18.3
	22 (25)	25 (25)	27 (27)	18.5 (20)	23.4 (23.4)	23 (23)	0.61	0.62	16.6	18.3
	30 (30)	33 (33)	35 (35)	22 (25)	28 (28)	27 (27)	0.80	0.80	16.6	18.3
	37 (40)	40 (40)	42 (42)	30 (30)	36.6 (36.6)	35 (35)	0.97	0.98	18.8	19.5
FSE	45 (50)	50 (50)	52 (52)	37 (40)	44.4 (44.4)	42 (42)	1.11	1.12	17.6	18.3
	55 (60)	59 (59)	62 (62)	45 (50)	54.4 (54.4)	52 (52)	1.35	1.36	26.7	28.7
FSF	75 (75)	78 (78)	80 (80)	55 (60)	66.4 (66.4)	62 (62)	1.41	1.41	61	68
	90 (100)	97 (97)	100 (100)	75 (75)	85.2 (85.2)	80 (80)	1.80	1.82	61	68
	110 (125)	121 (121)	125 (125)	90 (100)	106.3 (106.3)	100 (100)	2.22	2.25	66.5	71
	132 (150)	138 (138)	144 (144)	110 (125)	131.6 (131.6)	125 (125)	2.64	2.67	66.5	71
FSG	160 (n/a)	171 (171)	171 (171)	132 (150)	158.2 (158.2)	144 (144)	--	2.93	--	105
	200 (200)	205 (205)	208 (208)	160 (n/a)	185.1 (185.1)	171 (171)	--	3.70	--	113
	250 (250)	249 (249)	250 (250)	200 (200)	227.5 (227.5)	208 (208)	--	4.63	--	120
FSH	315 (350)	343 (375)	330 (345)	250 (250)	283 (307)	272 (295)	--	5.40	--	158
	355 (400)	401 (408)	385 (388)	315 (300)	327 (333)	314 (320)	--	6.19	--	158
	400 (450)	437 (461)	420 (432)	355 (350)	362 (381)	348 (367)	--	6.88	--	162
	450 (450)	489 (526)	470 (487)	400 (450)	410 (440)	394 (423)	--	7.72	--	162
FSJ	500 (500)	540 (591)	520 (546)	450 (450)	461 (501)	444 (482)	--	8.13	--	236
	560 (600)	602 (665)	580 (610)	500 (500)	494 (543)	476 (523)	--	8.83	--	236
	630 (700)	675 (737)	650 (679)	560 (500)	552 (602)	532 (580)	--	9.94	--	246

*11.4 Technical data dependent on the power*

\* For systems according to UL: 500 V ... 600 V

## 11.5 Derating data

### 11.5.1 Current derating as a function of the installation altitude

The permissible converter output current is reduced above an installation altitude of 1000 m.

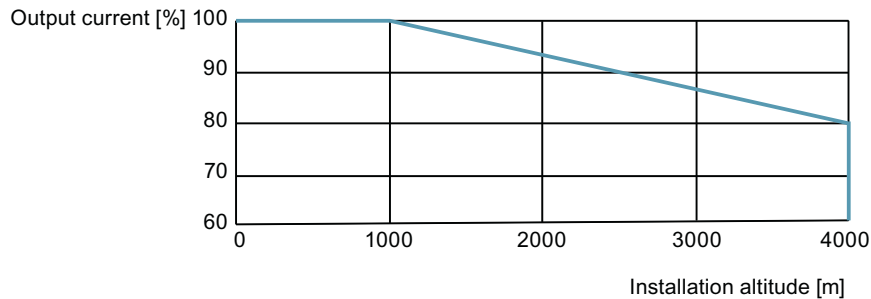

#### Permissible line supplies dependent on the installation altitude

- For installation altitudes  $\leq 2000$  m above sea level, it is permissible to connect the converter to any of the line supplies that are specified for it.
- For installation altitudes 2000 m ... 4000 m above sea level, the following applies:
  - Connection to a TN line system with grounded neutral point is permissible.
  - TN systems with grounded line conductor are not permitted.
  - The TN line system with grounded neutral point can also be supplied using an isolation transformer.
  - The phase-to-phase voltage does not have to be reduced.

---

#### Note

**Using converters connected to TN line supplies with voltages  $\geq 600$  V for installation altitudes 2000 m ... 4000 m**

For voltages  $\geq 600$  V, the TN line supply must have a grounded neutral point established using an isolation transformer.

---

### 11.5.2 Current derating as a function of the ambient temperature

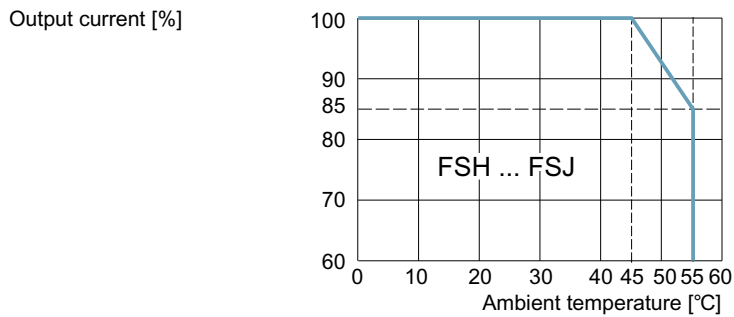
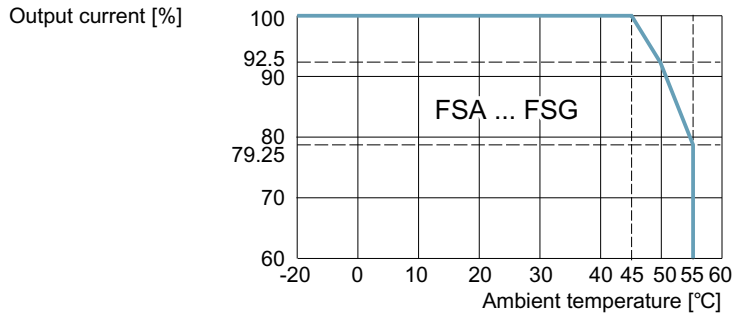

Note that Operator Panel can restrict the maximum permissible operating ambient temperature of the converter.

### 11.5.3 Current derating as a function of the line voltage

#### 400 V converters

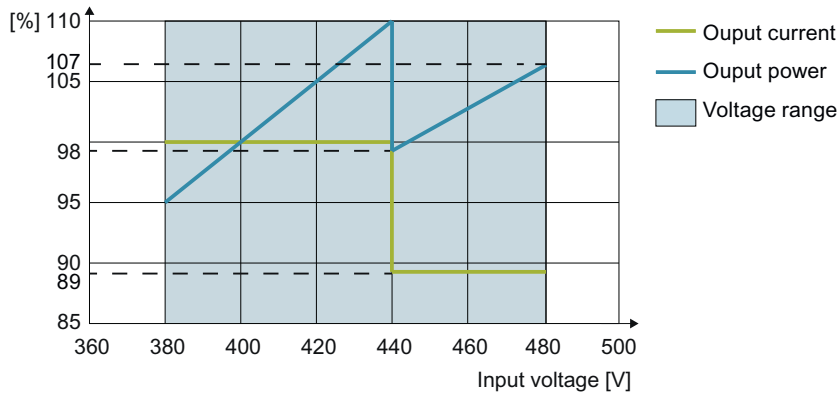

Figure 11-1 Current and voltage derating as a function of the input voltage for FSA ... FSG

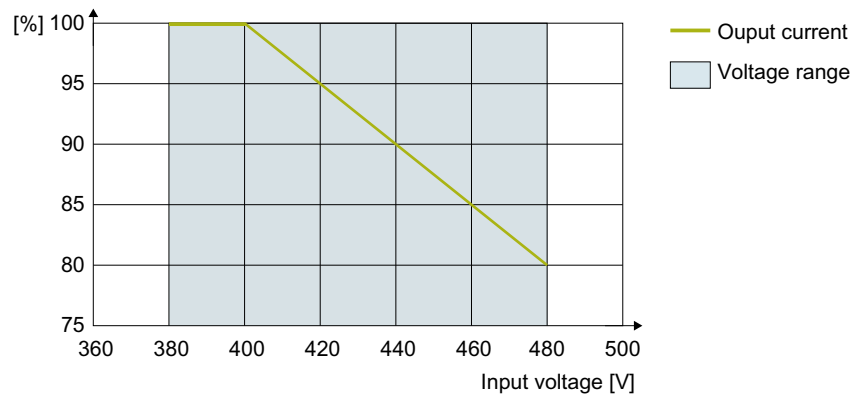

Figure 11-2 Current derating as a function of the input voltage for FSH/FSJ

### 690 V converters

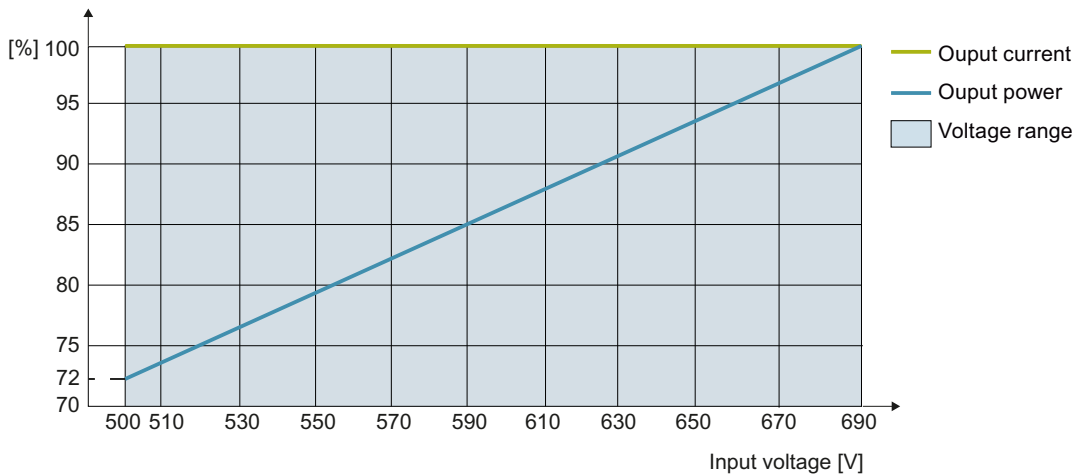

Figure 11-3 Current and voltage derating as a function of the input voltage for FSA .. FSG

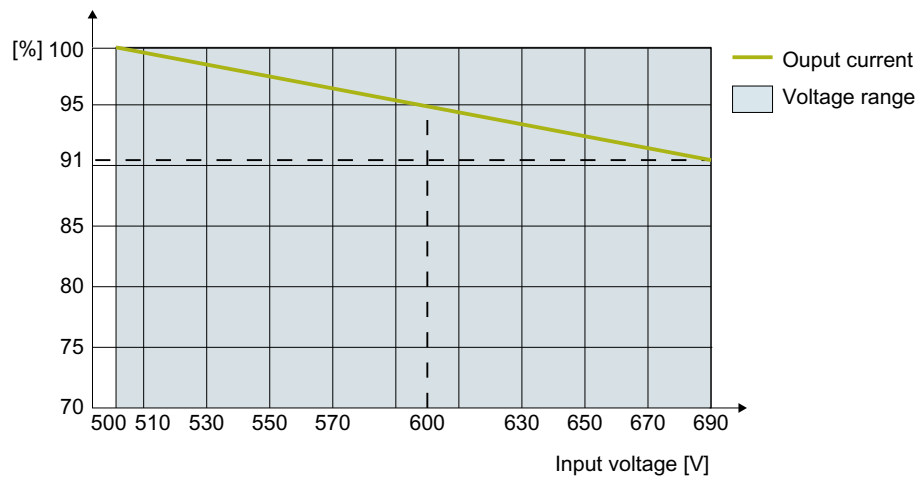

Figure 11-4 Current derating as a function of the input voltage for FSH/FSJ

## 11.5.4 Current derating as a function of the pulse frequency

### FSA ... FSG converters

Table 11-1 400 V variants

Frame size	Rated power based on LO (kW)	Output current (A) (at 400 V, 45 °C ambient temperature) for a pulse frequency of							
		2 kHz	4 kHz	6 kHz	8 kHz	10 kHz	12 kHz	14 kHz	16 kHz
FSA	0.75	2.2	<b>2.2</b>	1.87	1.54	1.32	1.1	0.99	0.88
	1.1	3.1	<b>3.1</b>	2.635	2.17	1.86	1.55	1.395	1.24
	1.5	4.1	<b>4.1</b>	3.485	2.87	2.46	2.05	1.895	1.64
	2.2	5.9	<b>5.9</b>	5.015	4.13	3.54	2.95	2.655	2.36
	3	7.7	<b>7.7</b>	6.545	5.39	4.62	3.85	3.465	3.08
FSB	4	10.2	<b>10.2</b>	8.67	7.14	6.12	5.1	4.59	4.08
	5.5	13.2	<b>13.2</b>	11.22	9.24	7.92	6.6	5.94	5.28
	7.5	18	<b>18</b>	15.3	12.6	10.8	9	8.1	7.2
FSC	11	26	<b>26</b>	22.1	18.2	15.6	13	11.7	10.4
	15	32	<b>32</b>	27.2	22.4	19	18	14.4	12.8
FSD	18.5	38	<b>38</b>	32.3	26.6	22.8	19	17.1	15.2
	22	45	<b>45</b>	38.2	31.5	27	22.5	20.2	18
	30	60	<b>60</b>	51	42	36	30	27	24
	37	75	<b>75</b>	63.7	52.5	45	37.5	33.7	30
FSE	45	90	<b>90</b>	76.5	63	54	45	40.5	36
	55	110	<b>110</b>	93.5	77	66	55	49.5	44
FSF	75	145	<b>145</b>	123.2	101.5	87	72.5	65.2	58
	90	178	<b>178</b>	151	124.6	107	89	80.1	71.2
	110	<b>205</b>	143.5	103	82	--	--	--	--
	132	<b>250</b>	175	125	100	--	--	--	--
FSG	160	<b>302</b>	211.4	151	121	--	--	--	--
	200	<b>370</b>	259	185	148	--	--	--	--
	250	<b>477</b>	334	239	191	--	--	--	--
FSH	315	<b>585</b>	468 <sup>1)</sup>	--	--	--	--	--	--
	355	<b>655</b>	524 <sup>1)</sup>	--	--	--	--	--	--
	400	<b>735</b>	588 <sup>1)</sup>	--	--	--	--	--	--
FSJ	450	<b>840</b>	672 <sup>1)</sup>	--	--	--	--	--	--
	500	<b>910</b>	728 <sup>1)</sup>	--	--	--	--	--	--
	560	<b>1021</b>	817 <sup>1)</sup>	--	--	--	--	--	--

The rated output currents in bold refer to the default pulse frequency at 45 °C ambient temperature.

<sup>1)</sup> In the factory setting, the converter starts with a pulse frequency of 4 kHz and reduces automatically the pulse frequency to the associated required frequencies when loaded. When the load decreases, the pulse frequency is increased automatically up to 4 kHz.



Table 11-2 690 V variants

Frame Size	Rated power based on LO (kW)	Output current (A) (at 45 °C ambient temperature) for a pulse frequency of	
		2 kHz	4 kHz
FSD	3	<b>6</b>	3.6
	4	<b>7</b>	4.2
	5.5	<b>10</b>	6
	7.5	<b>13</b>	7.8
	11	<b>16</b>	9.6
	15	<b>21</b>	12.6
	18.5	<b>25</b>	15
	22	<b>29</b>	17.4
	30	<b>38</b>	22.8
	37	<b>46</b>	27.6
FSE	45	<b>58</b>	34.8
	55	<b>68</b>	40.8
FSF	75	<b>90</b>	54
	90	<b>112</b>	67.2
	110	<b>128</b>	76.8
	132	<b>158</b>	94.8
FSG	160	<b>196</b>	118
	200	<b>236</b>	142
	250	<b>288</b>	173
FSH	315	<b>330</b>	215 <sup>1)</sup>
	355	<b>385</b>	250 <sup>1)</sup>
	400	<b>420</b>	273 <sup>1)</sup>
	450	<b>470</b>	306 <sup>1)</sup>
FSJ	500	<b>520</b>	338 <sup>1)</sup>
	560	<b>580</b>	377 <sup>1)</sup>
	630	<b>650</b>	423 <sup>1)</sup>

The rated output currents in bold refer to the default pulse frequency at 45 °C ambient temperature.

- <sup>1)</sup> In the factory setting, the converter starts with a pulse frequency of 4 kHz and reduces automatically the pulse frequency to the associated required frequencies when loaded. When the load decreases, the pulse frequency is increased automatically up to 4 kHz.  
The values of the rated current refer to a pulse frequency of 2 kHz at 45 °C ambient temperature and are reached at any time by the automatic adaptation of the output pulse frequency.

## 11.6 Low frequency performance

The converter can only be operated with reduced output current at low output frequencies.

### NOTICE

#### Reduced converter service life as a result of overheating

Loading the converter with a high output current and at the same time with a low output frequency can cause the current-conducting components in the converter to overheat. Excessively high temperatures can damage the converter or reduce the converter service life.

- Never operate the converter continuously with an output frequency = 0 Hz.
- Only operate the converter in the permissible operating range.

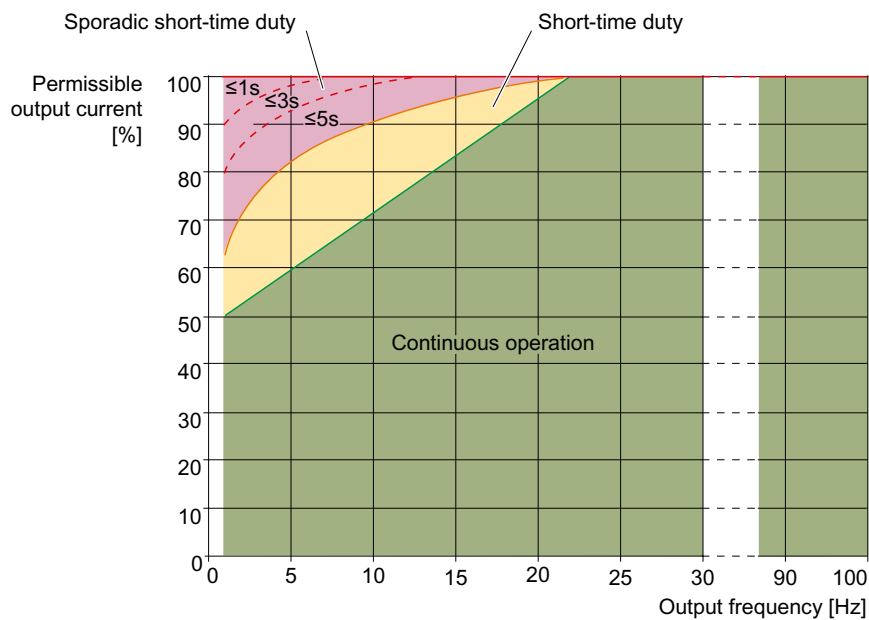

- Continuous operation (green area in the figure)  
Operating state that is permissible for the complete operating time.
- Short-time duty (yellow area in the figure)  
Operating state that is permissible for less than 2% of the total operating time.
- Sporadic short-time duty (red area in the figure)  
Operating state that is permissible for less than 0.1% of the total operating time.

## 11.7 Data regarding the power loss in partial load operation

You can find data regarding power loss in partial load operation in the Internet:

 Partial load operation (<http://support.automation.siemens.com/WW/view/en/94059311>)

## 11.8 Electromagnetic compability of the converter

### 11.8.1 Overview

#### Definition of terms

EMC stands for electromagnetic compatibility.

EMC means that the devices function satisfactorily without interfering with or being disrupted by other devices. EMC applies when both the emitted interference (emission level) and the interference immunity are matched with each other.

The product standard IEC/EN 61800-3 describes the EMC requirements placed on variable-speed drives.

A variable-speed drive (referred to as "Power Drive System", or PDS, in IEC/EN 61800-3) consists of the converter as well as the associated motors and encoders including the connecting cables.

The driven machine is not part of the drive.

#### General information

IEC/EN 61800-3 makes a distinction between the "first environment" and "second environment" – and defines different requirements for these environments.

- **First environment**  
Residential buildings or locations at which the drive is directly connected to the public low-voltage system without an intermediate transformer.
- **Second environment**  
An environment that includes all other equipment which is not connected directly to a public low-voltage line supply for residential buildings. These are basically industrial areas that have their own medium-voltage supply via their own transformers.

---

#### Note

The drive is intended for commercial or industrial use in stationary machines and systems.

---

#### Note

The drive is intended to be installed and put into operation by specially trained personnel, in observance of EMC conditions and the installation information in the operating instructions and "EMC layout guidelines" configuration manual.

 EMC installation guideline (<http://support.automation.siemens.com/WW/view/en/60612658>)

---

**Note****The drive as a component of machines or systems**

For the integration of the drive in machines or systems, additional measures may be necessary in order to comply with the product standards of these systems or machines. These additional measures are the responsibility of the system or machine manufacturer.

---

**Note**

In a residential environment, the drive may cause radio interference. In such cases, additional interference suppression measures may be required.

---

## 11.8.2 Operation in the Second EMC environment

### 11.8.2.1 High-frequency interference emissions EMC category C3

#### Description

The drive may be used in the second EMC environment if at least the limit values of IEC 61800-3 Category C3 with regard to conducted and radiated interference emissions are complied with. The following requirements must be met for this purpose:

- Operation on TN or TT line supply with star-point grounded
- Permissible motor cable length
  -  Maximum permissible motor cable length (Page 78)
- Shielded motor cable with low capacitance
- Pulse frequency  $\leq$  factory setting
- With line filter (external or internal)
  - Converters with integrated C2 line filter or C3 line filter
  - Unfiltered converters with external C2 line filter or C3 line filter

---

**Note**

If devices without integrated C3 filters or filters other than those listed above are used, the machine builder or plant engineer must certify that the emitted interference does not exceed the limit values of category C3. Separate line filters for each device or a shared line filter for several devices can be used.

---

### 11.8.2.2 High-frequency interference emissions EMC category C2

#### Description

The drive meets the limit values of IEC 61800-3 Category C2 with regard to conducted and radiated interference emissions under the following conditions:

- Operation on TN or TT line supply with grounded neutral point
- Permissible motor cable length
  -  Maximum permissible motor cable length (Page 78)
- Shielded motor cable with low capacitance
- Pulse frequency  $\leq$  factory setting
- With C2 line filter (external or internal)
  - Converters with integrated C2 line filter
  - Unfiltered FSA ... FSF converters with external C2 line filter
  - FSH/FSJ converters with external C2 line filter and line reactor

---

#### Note

If devices without integrated C2 filters or filters other than those listed above are used, the machine builder or plant engineer must certify that the emitted interference does not exceed the limit values of category C2. Separate line filters for each device or a shared line filter for several devices can be used.

---

### 11.8.2.3 Current harmonics

#### Overview

IEC 61800-3 does not define any limits for the emission of current harmonics when used in industrial networks. A system evaluation according to IEC 61000-3-14 or 61800-3 Annex B.4 is recommended.

## 11.8.3 Operation in the First EMC environment

### 11.8.3.1 General information

#### Overview

Devices and systems that are operated on the public low-voltage system must comply with the limit values for electromagnetic interference (interference immunity and interference emission) defined in the relevant standards. Industrial networks are facing increased requirements, particularly regarding emitted interference. The requirements for standard-conformant operation on the public low-voltage system are explained in more detail in the following.

---

#### Note

Requirements may be defined in the technical connection conditions of the local network operator that exceed the standard requirements described in this document.

---

#### Note

The flicker behavior can only be evaluated in a combination of the drive with an application (see IEC 61800-3, Section 6.2.4.2). The drive behaves passively in this regard, i.e. load fluctuations of the application will be visible without changes on the line side.

---

#### Note

##### Influence by ripple control signals

Ripple control signals in public supply systems can affect the operation of the drive system in unfavorable cases and cause fault shutdowns (e.g. "undervoltage" or "phase failure"). This particularly applies to FSA-C devices if they are operated in the factory-set U/f control mode.

- If ripple control signals are exerting unwanted influence, replace the U/f control mode (Standard Drive Control application class) with the vector control (Dynamic Drive Control application class).

### 11.8.3.2 High-frequency, conducted and radiated interference emissions, EMC Category C2

#### Description

The drive may only be used in the first EMC environment if at least the limit values of EMC Category C2 are adhered to in regard to the interference emissions. To this end, the requirements listed below must be satisfied:

- Operation on a TN or TT system with a grounded neutral point.
- Use of shielded motor cables with a length of max. 150 meters.
- Operation using the default pulse frequency (or with a reduced pulse frequency)

11.8 Electromagnetic compability of the converter

- FSA – FSG: Use converters with an integrated C2 line filter (-0AF0 in the last block of the article number)
- FSH, FSJ: Use of an external line filter
  - 400-480 V 3 AC: 6SL3760-0MR00-0AA0
  - 500-690 V 3 AC: 6SL3760-0MS00-0AA0

---

**Note**

If converters without integrated C2 filters or filters other than those listed above are used, the machine builder or plant engineer must certify that the interference emissions are limited according to EMC Category C2, at a minimum. Separate line filters for each converter or a shared line filter for several converters can be used.

---

### 11.8.3.3 High-frequency, conducted interference emissions, EMC Category C1

#### Description

In conjunction with upstream C1 line filters, the converter meets the limits of IEC 61800-3 Category C1 with respect to conducted interference.

Conditions for compliance with the limits:

- TN or TT system with a grounded neutral point.
- Use of shielded motor cables
- Compliance with maximum motor cable length
  -  Maximum permissible motor cable length (Page 78)
- Converter operation using the default pulse frequency or with reduced pulse frequency

### 11.8.3.4 Current harmonics of individual devices

#### Description

In regard to the adherence to limit values for the harmonic currents, the EMC product standard IEC 61800-3 for PDS refers to the compliance with standards IEC 61000-3-2 and IEC 61000-3-12. The limit values of these standards apply to devices that are designed for connecting to the public low-voltage system.



Depending on the rated output and the rated input current of the device, different requirements result for the direct connection to the low-voltage system.

LO base load power	LO input current	
≤ 1 kW	-	The converters comply with the requirements of IEC 61000-3-2.
> 1 kW	≤ 16 A	No limit value requirements are defined in IEC 61000-3-2 for professionally used devices of this output range. Notification of the network operator and a system evaluation according to IEC 61000-3-14 or 61800-3 Annex B.4 are recommended.
	> 16 A and ≤ 75 A	The converters comply with IEC 61000-3-12 (Table 4), provided that the short-circuit capacity (SSC) at the point of connection of the customer system to the public network is greater than or equal to the value in the formula below. $S_{SC} = U_{rated}^2 / Z \geq 120 \cdot \sqrt{3} \cdot U_{rated} \cdot I_{LO}$ The installer or plant operator must ensure that the converters are only connected to a supply system with sufficient short-circuit capacity. If the converters are to be connected to a supply system with a lower short-circuit capacity, the installer or plant operator must obtain a connection approval from the network operator in regard to harmonic currents.
	> 75 A:	No limit values for current harmonics are defined for these devices in the IEC standards. Notification of the network operator and a system evaluation according to IEC 61000-3-14 or 61800-3 Annex B.4 are recommended. The converters FSH and FSJ always require an upstream line reactor and an upstream line filter for operating on the public low-voltage system.

When operated with LO rated power, the converter generates the following typical current harmonics (as a percentage of the fundamental current):

Converter	R <sub>SC</sub>	I5	I7	I11	I13	I17	I19	I23	I25	THC
FSA ... FSG	120	38%	18%	8%	5%	4%	3%	3%	2%	43%
FSH, FSJ with 2% line reactor	50	37%	13%	7%	3%	3%	2%	1%	1%	40%

The SIZER configuration tool allows the individual calculation of the harmonic parameters.

 Download SIZER (<http://support.automation.siemens.com/WW/view/en/10804987/130000>)

### Line Harmonics Filter (LHF) for reducing current harmonics

The passive LHF (Line Harmonics Filters) available for the converter allow a significant reduction of the current harmonics. It is especially recommended that LHF be used if devices FSE ... FSG (above 75 A rated input current) are to be operated on the public low-voltage system.

11.8 Electromagnetic compability of the converter

Typical current harmonics with LHF when operating with LO rated power (in percentage of the fundamental current):

Converter	R <sub>sc</sub>	I5	I7	I11	I13	I15	I17	I23	I25	THC
FSB ... FSG / 400 V	33	1.7%	1.9%	2.2%	1.5%	0.8%	0.8%	0.7%	0.6%	4.2%
	120	1.8%	2.2%	2.4%	1.6%	0.8%	0.8%	0.7%	0.6%	4.4%

The power factor λ improves with LHF to approx. 98% when operating with rated output.

With an upstream LHF, the converters satisfy the limit values of IEC 61000-3-2 and IEC 61000-3-12.

**11.8.3.5 Harmonics at the power supply connection point acc. to IEC 6100-2-2**

**Description**

IEC 61000-2-2 defines the compatibility level for voltage harmonics for the point of common coupling (PCC) with the public supply system.

For systems in which converters or other non-linear loads are widely used, a circuit feedback calculation that takes the individual system configuration into consideration should always be performed.

The converter with upstream Line Harmonics Filters (LHF) allows adherence to the compatibility level for voltage harmonics, regardless of what percentage of the overall load is made up of the converter load.

**Note**

The voltage distortions behavior in the frequency range of 2 kHz to 9 kHz (IEC 61000-2-2 AMD 1) and from 9 kHz to 150 kHz (IEC 61000-2-2 AMD 2) must be evaluated specifically for each system as a function of the impedance at the power supply connection point.

**11.8.3.6 Harmonics at the power supply connection point acc. to IEEE 519**

**Description**

IEEE 519 defines limit values for voltage and current harmonics for all of the loads at the point of common coupling (PCC).

As a rule, systems only satisfy the limit values of IEEE 519 without implementing special measures if the share of converters and other non-linear loads in the overall load is relatively low. The respective system should always be individually considered.

The converter with upstream Line Harmonics Filters (LHF) enables adherence to the limit values of IEEE 519 (precondition: R<sub>sc</sub> ≥ 20).

**See also**

Maximum permissible motor cable length (Page 78)

EMC-compliant setup of the machine or plant (Page 48)

## 11.9 Protecting persons from electromagnetic fields

### Overview

Protection of workers from electromagnetic fields is specified in the European EMF Directive 2013/35/EU. This directive is implemented in national law in the European Economic Area (EEA). Employers are obligated to design workplaces in such a way that workers are protected from impermissibly strong electromagnetic fields.

To this end, assessments and/or measurements must be performed for workplaces.

### Precondition

1. The laws for protection from electromagnetic fields in force in individual EU member states can go beyond the minimum requirements of the EMF Directive 2013/35/EU and always take precedence.
2. The ICNIRP 2010 limits for the workplace are the basis for the assessment.
3. The 26th BImSchV (German Federal Emission Protection Regulation) defines 100  $\mu\text{T}$  (RMS) for the assessment of active implants.  
According to Directive 2013/35/EU, 500  $\mu\text{T}$  (RMS) at 50 Hz is applicable here.
4. Compliance with the limit values was assessed for the following frequencies:
  - Line frequency 47 ... 63 Hz
  - Pulse frequency, for example 4/8/16 kHz and multiples thereof, assessed up to a maximum of 100 kHz
5. The routing of power cables has a significant impact on the electromagnetic fields that occur. Install and operate the components inside metallic cabinets in compliance with the documentation and use shielded motor cables.  
 EMC-compliant setup of the machine or plant (Page 48)

### Description

The following information regarding electromagnetic fields relates solely to converters supplied by Siemens.

The converters are normally used in machines. The assessment and testing is based on DIN EN 12198.

The indicated minimum distances apply to the head and complete torso of the human body. Shorter distances are possible for extremities.

Table 11-3 Minimum distances to the converter

Individuals without active implants		Individuals with active implants	
Control cabinet closed	Control cabinet open	Control cabinet closed	Control cabinet open
0 cm	Forearm length (approx. 35 cm)	Must be separately assessed depending on the active implant.	

**See also**

EMC installation guideline (<http://support.automation.siemens.com/WW/view/en/60612658>)



## Appendix

### A.1 Handling the BOP-2 operator panel

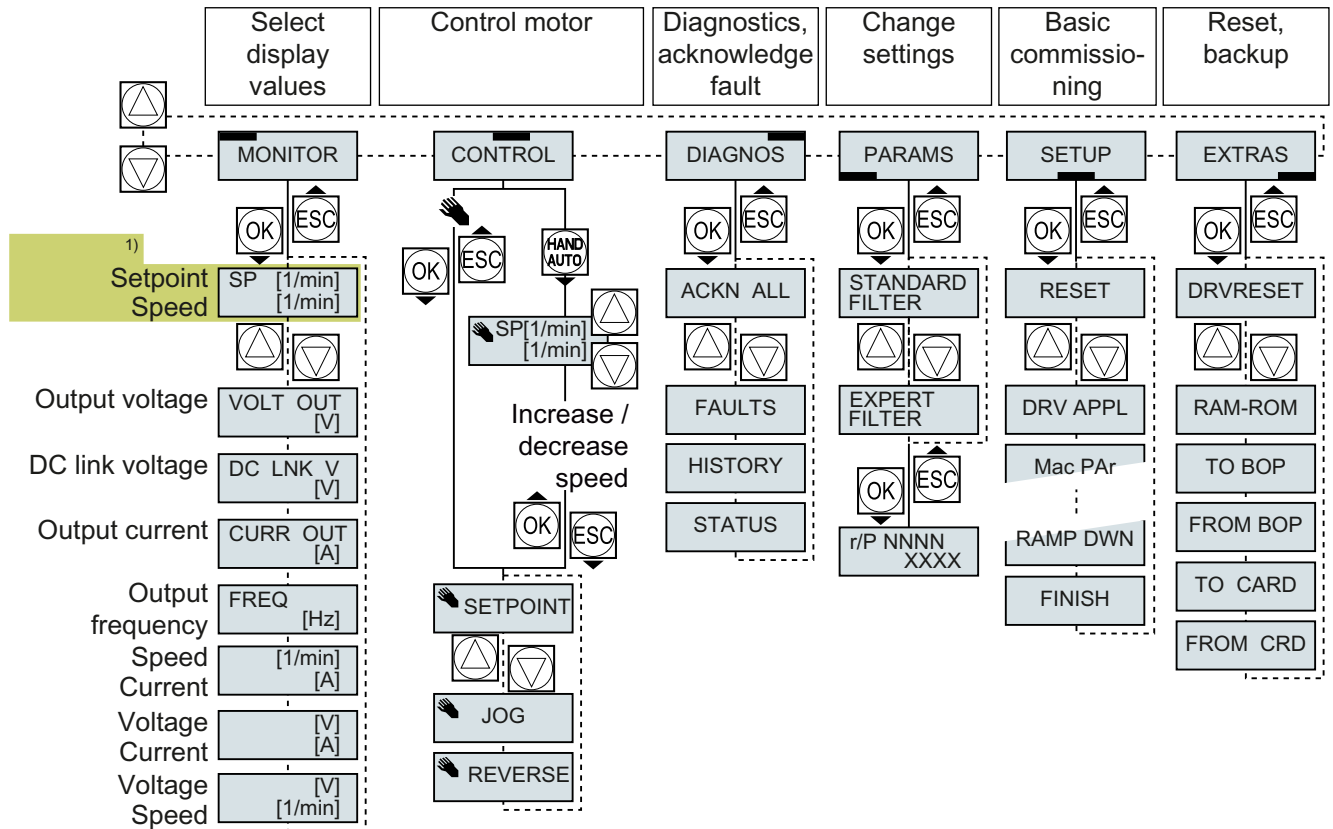

<sup>1)</sup> Status display once the power supply for the converter has been switched on.

Figure A-1 Menu of the BOP-2

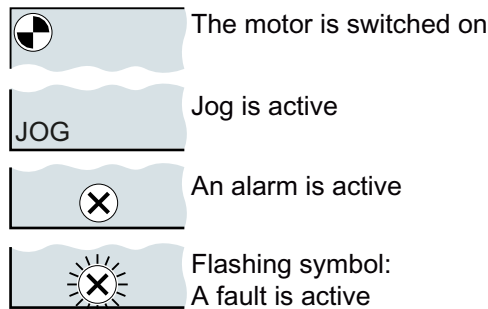





Figure A-2 Other keys and symbols of the BOP-2

Procedure for switching the motor on and off via the operator panel:

1. Press MANUAL AUTO 
2. Master control of the inverter is released via the BOP-2 
3. Switch on motor 
4. Switch off the motor 

### A.1.1 Changing settings using BOP-2

#### Changing settings using BOP-2

You can modify the settings of your converter by changing the values of the its parameters. The converter only permits changes to "write" parameters. Write parameters begin with a "P", e.g. P45.

The value of a read-only parameter cannot be changed. Read-only parameters begin with an "r", for example: r2.

The converter retentively saves all the changes made using the BOP-2 so that they are protected against power failure.

#### Procedure

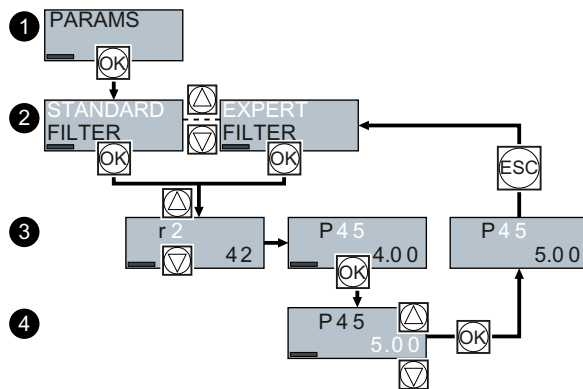

1. Select the menu to display and change parameters.  
Press the OK key.
2. Select the parameter filter using the arrow keys.  
Press the OK key.
  - STANDARD: The converter only displays the most important parameters.
  - EXPERT: The converter displays all of the parameters.
3. Select the required number of a write parameter using the arrow keys.  
Press the OK key.
4. Select the value of the write parameter using the arrow keys.  
Accept the value with the OK key.

You have now changed a write parameter using the BOP-2.

□



## A.1.2 Changing indexed parameters

### Changing indexed parameters

For indexed parameters, several parameter values are assigned to a parameter number. Each of the parameter values has its own index.

#### Procedure

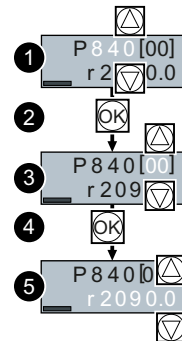

1. Select the parameter number.
2. Press the OK key.
3. Set the parameter index.
4. Press the OK key.
5. Set the parameter value for the selected index.

You have now changed an indexed parameter.

□

### A.1.3 Directly entering the parameter number and value

#### Directly select the parameter number

The BOP-2 offers the possibility of setting the parameter number digit by digit.

##### Precondition

The parameter number is flashing in the BOP-2 display.

##### Procedure

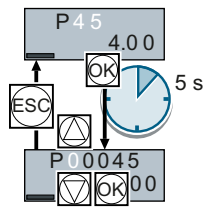

1. Press the OK button for longer than five seconds.
2. Change the parameter number digit-by-digit.  
If you press the OK button then the BOP-2 jumps to the next digit.
3. If you have entered all of the digits of the parameter number, press the OK button.

You have now entered the parameter number directly.

□

#### Entering the parameter value directly

The BOP-2 offers the option of setting the parameter value digit by digit.

##### Precondition

The parameter value flashes in the BOP-2 display.

##### Procedure

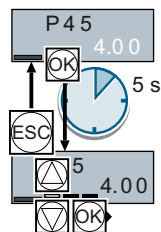

1. Press the OK button for longer than five seconds.
2. Change the parameter value digit-by-digit.  
If you press the OK button then the BOP-2 jumps to the next digit.
3. If you have entered all of the digits of the parameter value, press the OK button.

You have now entered the parameter value directly.

□

### A.1.4 A parameter cannot be changed

#### When cannot you change a parameter?

The converter indicates why it currently does not permit a parameter to be changed:

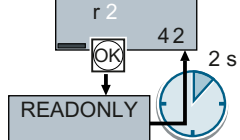
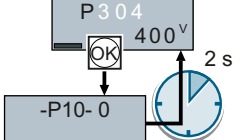
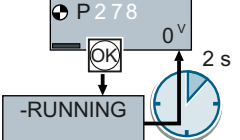
Read parameters cannot be adjusted	The parameter can only be adjusted during quick commissioning.	A parameter can only be adjusted when the motor is switched off
		

For each parameter, the parameter list contains the operating state in which the parameter can be changed.

## A.2 Interconnecting signals in the converter

The following functions are implemented in the converter:

- Open-loop and closed-loop control functions
- Communication functions
- Diagnosis and operating functions

Every function comprises one or several blocks that are interconnected with one another.

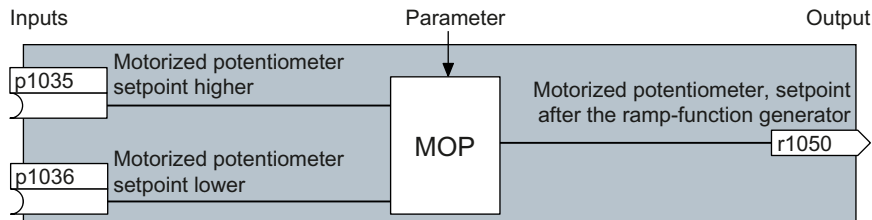

Figure A-3 Example of a block: Motorized potentiometer (MOP)

Most of the blocks can be adapted to specific applications using parameters.

You cannot change the signal interconnection within the block. However, the interconnection between blocks can be changed by interconnecting the inputs of a block with the appropriate outputs of another block.

The signal interconnection of the blocks is realized, contrary to electric circuitry, not using cables, but in the software.

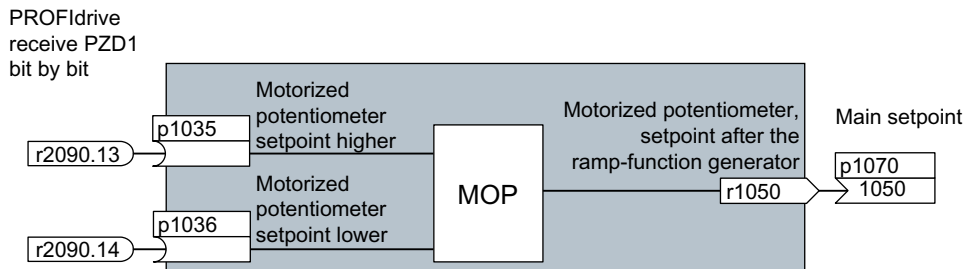

Figure A-4 Example: Signal interconnection of two blocks for digital input 0

## Binectors and connectors

Connectors and binectors are used to exchange signals between the individual blocks:

- Connectors are used to interconnect "analog" signals (e.g. MOP output speed)
- Binectors are used to interconnect digital signals (e.g. "Enable MOP up" command)

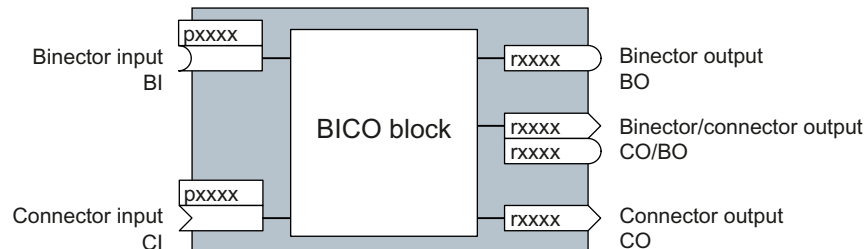

Figure A-5 Symbols for binector and connector inputs and outputs

Binector/connector outputs (CO/BO) are parameters that combine more than one binector output in a single word (e.g. r0052 CO/BO: status word 1). Each bit in the word represents a digital (binary) signal. This summary reduces the number of parameters and simplifies parameter assignment.

Binector or connector outputs (CO, BO or CO/BO) can be used more than once.

## Interconnecting signals

### When must you interconnect signals in the converter?

If you change the signal interconnection in the converter, you can adapt the converter to a wide range of requirements. This does not necessarily have to involve highly complex functions.

Example 1: Assign a different function to a digital input.

Example 2: Switch the speed setpoint from the fixed speed to the analog input.

### Principle when connecting BICO blocks using BICO technology

When interconnecting the signal, the following principle applies: **Where does the signal come from?**

An interconnection between two BICO blocks consists of a connector or a binector and a BICO parameter. The input of a block must be assigned the output of a different block: In the BICO parameters, enter the parameter numbers of the connector/binector that should supply its output signal to the BICO parameter.

### How much care is required when you change the signal interconnection?

Note which changes you make. A subsequent analysis of the set signal interconnections is possible only by evaluating the parameter list.

### Where can you find additional information?

- All the binectors and connectors are located in the Parameter list.
- The function diagrams provide a complete overview of the factory setting for the signal interconnections and the setting options.

## A.3 Manuals and technical support

### A.3.1 Overview of the manuals

#### Manuals with additional information that can be downloaded

-  Compact hardware installation instructions (<https://support.industry.siemens.com/cs/us/en/view/109762897>)  
Installing the converter  

-  Operating instructions (<https://support.industry.siemens.com/cs/us/en/view/109762826>)  
Installing, commissioning and maintaining the converter. Advanced commissioning (this manual)  

-  BOP-2 operating instructions (<https://support.industry.siemens.com/cs/ww/en/view/109483379>)  
Operating the converter with the BOP-2 operator panel  

-  Operating instructions IOP-2 (<https://support.industry.siemens.com/cs/ww/en/view/109752613>)  
Operating the converter with the IOP-2 operator panel  

-  SINAMICS G120 Smart Access Operating Instructions (<https://support.industry.siemens.com/cs/ww/en/view/109758122>)  
Operating the converter from a PC, tablet or smartphone  

-  Protective devices (<https://support.industry.siemens.com/cs/us/en/view/109762895>)  
Overcurrent protection devices of the converter  

## A.3.2 Configuring support

### Catalog

Ordering data and technical information for the converter.



Catalogs for download or online catalog (Industry Mall):

 SINAMICS G120X ([www.siemens.com/sinamics-g120x](http://www.siemens.com/sinamics-g120x))

### EMC (electromagnetic compatibility) technical overview

Standards and guidelines, EMC-compliant control cabinet design



 EMC overview (<https://support.industry.siemens.com/cs/ww/en/view/103704610>)

### EMC Guidelines configuration manual

EMC-compliant control cabinet design, potential equalization and cable routing



 EMC installation guideline (<http://support.automation.siemens.com/WW/view/en/60612658>)

### A.3.3 Product Support

You can find additional information about the product on the Internet:



Product support (<https://support.industry.siemens.com/cs/ww/en/>)

This URL provides the following:

- Up-to-date product information (product announcements)
- FAQs
- Downloads
- The Newsletter contains the latest information on the products you use.
- The Knowledge Manager (Intelligent Search) helps you find the documents you need.
- Users and specialists from around the world share their experience and knowledge in the Forum.
- You can find your local representative for Automation & Drives via our contact database under "Contact & Partner".
- Information about local service, repair, spare parts and much more can be found under "Services".



# Index

## 3

3RK3 (modular safety system), 113

## 8

87 Hz characteristic, 93

87 Hz characteristic, 93

## A

AC/DC drive profile, 196

Acceleration precontrol scaling

p1496[0...n], 550, 551

Acceptance test

Reduced scope, 894

Test scope, 894

Access level

p0003, 376

Acknowledge drive object faults

p3981, 682

Activate PN interface configuration

p8925, 711

Activate/deactivate RTC alarm A01098

p8405, 698

Actual macro

r9463, 716

Actual motor magnetizing current/short-circuit current

r0331[0...n], 421

Actual motor operating hours

p0650[0...n], 449

Actual power unit type

r0203[0...n], 401

Actual rotor resistance

r0396[0...n], 429

Actual speed rpm smoothed

r0022, 379

Actual stator resistance

r0395[0...n], 429

Actual torque smoothed

r0031, 380

Acyclic communication, 189

Additional acceleration torque (sensorless)

p1611[0...n], 560

Additional technology controller 0, 218

Air barrier, 53

Alarm, 292, 777, 782

Alarm buffer, 292, 782

Alarm code, 782

r2122[0...63], 605

Alarm counter

p2111, 603

Alarm history, 783

Alarm number

r2110[0...63], 603

Alarm time, 292, 782

Alarm time received in days

r2145[0...63], 612

Alarm time received in milliseconds

r2123[0...63], 606

Alarm time removed in days

r2146[0...63], 612

Alarm time removed in milliseconds

r2125[0...63], 606

Alarm value, 782

r2124[0...63], 606

Alarm value for float values

r2134[0...63], 609

Alert

A01009 (N), 790

A01016 (F), 791

A01017, 791

A01019, 792

A01020, 792

A01021, 792

A01028 (F), 793

A01035 (F), 793

A01045, 797

A01049, 797

A01066, 798

A01067, 798

A01069, 799

A01073 (N), 799

A01098, 800

A01251, 801

A01514 (F), 804

A01590 (F), 805

A01900 (F), 805

A01920 (F), 806

A01945, 806

A02150, 806

A03510 (F, N), 808

A03520 (F, N), 809

A05000 (N), 809

A05001 (N), 809

A05002 (N), 809

A05003 (N), 810  
A05004 (N), 810  
A05006 (N), 810  
A05065 (F, N), 810  
A07012 (N), 811  
A07014 (N), 812  
A07015, 812  
A07089, 815  
A07094, 815  
A07200, 815  
A07321, 817  
A07325, 817  
A07352, 818  
A07353, 818  
A07391, 819  
A07400 (N), 819  
A07401 (N), 819  
A07402 (N), 819  
A07409 (N), 820  
A07416, 821  
A07427, 822  
A07428 (N), 822  
A07444, 823  
A07530, 823  
A07531, 824  
A07805 (N), 825  
A07850 (F), 826  
A07851 (F), 826  
A07852 (F), 826  
A07891, 827  
A07892, 827  
A07893, 828  
A07903, 829  
A07910 (N), 830  
A07920, 830  
A07921, 830  
A07922, 831  
A07926, 831  
A07927, 832  
A07929 (F), 832  
A07980, 835  
A07981, 835  
A07991 (N), 839  
A07994 (F, N), 840  
A08511 (F), 840  
A08526 (F), 841  
A08564, 841  
A08565, 841  
A30016 (N), 846  
A30030, 850  
A30031, 850  
A30032, 850  
A30033, 851  
A30034, 851  
A30042, 852  
A30049, 853  
A30057, 853  
A30065 (F, N), 854  
A30502, 856  
A30810 (F), 858  
A30920 (F), 859  
A30999 (F, N), 859  
A50010 (F), 859  
A50011 (F), 860  
A52961, 860  
A52962, 860  
A52963, 860  
A52964, 861  
A52966, 861  
F01000, 788  
F01001, 788  
F01002, 789  
F01003, 789  
F01005, 790  
F01010, 790  
F01015, 790  
F01018, 791  
F01023, 792  
F01030, 793  
F01033, 793  
F01034, 793  
F01036 (A), 794  
F01038 (A), 794  
F01039 (A), 795  
F01040, 795  
F01042, 796  
F01043, 796  
F01044, 797  
F01054, 798  
F01068, 799  
F01072, 799  
F01105 (A), 800  
F01107, 800  
F01112, 800  
F01120 (A), 801  
F01152, 801  
F01205, 801  
F01250, 801  
F01257, 802  
F01340, 802  
F01505 (A), 803  
F01510, 803  
F01511 (A), 803  
F01512, 804

F01513 (N, A), 804	F07902 (N, A), 829
F01515 (A), 805	F07923, 831
F01662, 805	F07924, 831
F01910 (N, A), 805	F07925, 831
F01946 (A), 806	F07936, 832
F02151 (A), 807	F07950 (A), 833
F02152 (A), 807	F07967, 833
F03000, 807	F07968, 833
F03001, 808	F07969, 833
F03505 (N, A), 808	F07983, 835
F06310 (A), 811	F07984, 836
F07011, 811	F07985, 837
F07016, 812	F07986, 838
F07080, 813	F07988, 838
F07082, 813	F07990, 838
F07083, 814	F08010 (N, A), 840
F07084, 814	F08501 (N, A), 840
F07086, 815	F08502 (A), 840
F07088, 815	F13009, 841
F07220 (N, A), 816	F13100, 841
F07300 (A), 816	F13101, 842
F07311, 816	F13102, 842
F07312, 816	F30001, 843
F07320, 817	F30002, 843
F07330, 817	F30003, 844
F07331, 818	F30004, 844
F07332, 818	F30005, 844
F07390, 818	F30011, 845
F07405 (N, A), 820	F30012, 845
F07406 (N, A), 820	F30013, 845
F07410, 820	F30015 (N, A), 846
F07411, 820	F30017, 846
F07426 (A), 821	F30021, 847
F07435 (N), 822	F30022, 847
F07436 (A), 822	F30024, 847
F07437 (A), 822	F30025, 848
F07438 (A), 823	F30027, 848
F07445, 823	F30035, 851
F07800, 824	F30036, 852
F07801, 824	F30037, 852
F07802, 824	F30051, 853
F07806, 825	F30052, 853
F07807, 825	F30059, 854
F07810, 826	F30068, 854
F07860 (A), 826	F30071, 854
F07861 (A), 827	F30072, 854
F07862 (A), 827	F30074 (A), 854
F07894, 828	F30075, 855
F07895, 828	F30080, 855
F07896, 828	F30081, 856
F07900 (N, A), 828	F30105, 856
F07901, 829	F30662, 857

- F30664, 857
  - F30802, 857
  - F30804 (N, A), 857
  - F30805, 858
  - F30809, 858
  - F30850, 858
  - F30903, 858
  - F30950, 859
  - F35950, 859
  - F52960, 860
  - F52965, 861
  - N01004 (F, A), 789
  - N01101 (A), 800
  - N30800 (F), 857
  - Ambient temperature, 329, 330
  - Analog input, 99
    - Function, 165
  - Analog output, 99
    - Function, 171
  - Application class
    - p0096, 398, 399
  - Application example, 121, 155, 171, 258, 259
    - Application example, 160, 168
  - Automatic calculation motor/control parameters
    - p0340[0...n], 422
  - Automatic mode, 214, 215
  - Automatic restart, 342
  - Automatic restart delay time start attempts
    - p1212, 521
  - Automatic restart faults not active
    - p1206[0...9], 519
  - Automatic restart mode
    - p1210, 519
  - Automatic restart monitoring time
    - p1213[0...1], 521
  - Automatic restart start attempts
    - p1211, 520
- B**
- Bearing code number selection
    - p0531[0...n], 437
  - Bearing maximum speed
    - p0532[0...n], 437
  - Bearing version selection
    - p0530[0...n], 436
  - BF (Bus Fault), 778, 779
  - Bl: 1st acknowledge faults
    - p2103[0...n], 600
  - Bl: 2/3 wire control command 1
    - p3330[0...n], 670
  - Bl: 2/3 wire control command 2
    - p3331[0...n], 671
  - Bl: 2/3 wire control command 3
    - p3332[0...n], 671
  - Bl: 2nd acknowledge faults
    - p2104[0...n], 601
  - Bl: 3rd acknowledge faults
    - p2105[0...n], 601
  - Bl: Active STW1 in the BOP/IOP manual mode
    - p8542[0...15], 705
  - Bl: Binector-connector converter status word 1
    - p2080[0...15], 591
  - Bl: Binector-connector converter status word 2
    - p2081[0...15], 591
  - Bl: Binector-connector converter status word 3
    - p2082[0...15], 592
  - Bl: Binector-connector converter status word 4
    - p2083[0...15], 593
  - Bl: Binector-connector converter status word 5
    - p2084[0...15], 593
  - Bl: Bypass control command
    - p1266, 531
  - Bl: Bypass switch feedback signal
    - p1269[0...1], 532
  - Bl: Close main contactor
    - p0870, 481
  - Bl: Command data set selection CDS bit 0
    - p0810, 471
  - Bl: Command data set selection CDS bit 1
    - p0811, 471
  - Bl: Continue ramp-function generator/freeze ramp-function generator
    - p1141[0...n], 514
  - Bl: Control by PLC/no control by PLC
    - p0854[0...n], 478
  - Bl: CU analog outputs invert signal source
    - p0782[0...2], 465
  - Bl: CU signal source for terminal DO 0
    - p0730, 452
  - Bl: CU signal source for terminal DO 1
    - p0731, 453
  - Bl: CU signal source for terminal DO 2
    - p0732, 453
  - Bl: CU signal source for terminal DO 3
    - p0733, 454
  - Bl: CU signal source for terminal DO 4
    - p0734, 454
  - Bl: CU signal source for terminal DO 5
    - p0735, 455
  - Bl: DC braking activation
    - p1230[0...n], 523

- BI: Deragging enable  
p29591[0...n], 748
- BI: Drive Data Set selection DDS bit 0  
p0820[0...n], 472
- BI: Drive Data Set selection DDS bit 1  
p0821[0...n], 472
- BI: Dual ramp enable  
p29580[0...n], 747
- BI: Enable energy usage display  
p0043, 385
- BI: Enable operation/inhibit operation  
p0852[0...n], 477
- BI: Enable ramp-function generator/inhibit ramp-  
function generator  
p1140[0...n], 514
- BI: Enable setpoint/inhibit setpoint  
p1142[0...n], 515
- BI: ESM activation signal source  
p3880, 676
- BI: ESM direction of rotation signal source  
p3883, 677
- BI: External alarm 1  
p2112[0...n], 603
- BI: External alarm 2  
p2116[0...n], 604
- BI: External alarm 3  
p2117[0...n], 604
- BI: External fault 1  
p2106[0...n], 601
- BI: External fault 2  
p2107[0...n], 601
- BI: External fault 3  
p2108[0...n], 602
- BI: External fault 3 enable  
p3111[0...n], 661
- BI: External fault 3 enable negated  
p3112[0...n], 661
- BI: Fixed speed setpoint selection Bit 0  
p1020[0...n], 493
- BI: Fixed speed setpoint selection Bit 1  
p1021[0...n], 493
- BI: Fixed speed setpoint selection Bit 2  
p1022[0...n], 493
- BI: Fixed speed setpoint selection Bit 3  
p1023[0...n], 494
- BI: Flying restart enable signal source  
p1201[0...n], 518
- BI: Free tec\_ctrl 0 enable  
p11000, 718
- BI: Free tec\_ctrl 1 enable  
p11100, 725
- BI: Free tec\_ctrl 2 enable  
p11200, 732
- BI: Frost protection enable  
p29622[0...n], 751
- BI: Hold technology controller integrator  
p2286[0...n], 640
- BI: Inhibit master control  
p0806, 470
- BI: Inhibit negative direction  
p1110[0...n], 508
- BI: Inhibit positive direction  
p1111[0...n], 508
- BI: Jog bit 0  
p1055[0...n], 499
- BI: Jog bit 1  
p1056[0...n], 500
- BI: Limit switch minus  
p3343[0...n], 672
- BI: Limit switch plus  
p3342[0...n], 672
- BI: Limit switch start  
p3340[0...n], 671
- BI: Line contactor feedback signal  
p0860, 479
- BI: Load monitoring failure detection  
p3232[0...n], 666
- BI: Motor stall monitoring enable (negated)  
p2144[0...n], 611
- BI: Motorized potentiometer accept setting value  
p1043[0...n], 497
- BI: Motorized potentiometer inversion  
p1039[0...n], 496
- BI: Motorized potentiometer lower setpoint  
p1036[0...n], 496
- BI: Motorized potentiometer manual/automatic  
p1041[0...n], 497
- BI: Motorized potentiometer setpoint raise  
p1035[0...n], 495
- BI: Multi-pump control motor under repair  
p29543[0...3], 744
- BI: No coast-down / coast-down (OFF2) signal source  
1  
p0844[0...n], 475
- BI: No coast-down / coast-down (OFF2) signal source  
2  
p0845[0...n], 475, 476
- BI: No Quick Stop / Quick Stop (OFF3) signal source  
1  
p0848[0...n], 476
- BI: No Quick Stop / Quick Stop (OFF3) signal source  
2  
p0849[0...n], 477

- Bl: ON / OFF (OFF1)  
p0840[0...n], 474
- Bl: ON/OFF1 (OFF1)  
p29651[0...n], 755
- Bl: ON/OFF2 (OFF2)  
p29652[0...n], 755
- Bl: Pe set switching on inhibited signal source  
p5614, 689
- Bl: Ramp-function generator, accept setpoint  
p29642, 754
- Bl: Ramp-function generator, accept setting value  
p1143[0...n], 515
- Bl: RFG active  
p2148[0...n], 612
- Bl: Select IOP manual mode  
p8558, 706
- Bl: Setpoint inversion  
p1113[0...n], 509
- Bl: Technology controller enable  
p2200[0...n], 625
- Bl: Technology controller fixed value selection bit 0  
p2220[0...n], 629
- Bl: Technology controller fixed value selection bit 1  
p2221[0...n], 629
- Bl: Technology controller fixed value selection bit 2  
p2222[0...n], 629
- Bl: Technology controller fixed value selection bit 3  
p2223[0...n], 630
- Bl: Technology controller limiting enable  
p2290[0...n], 640
- Bl: Technology controller motorized potentiometer  
lower setpoint  
p2236[0...n], 632
- Bl: Technology controller motorized potentiometer  
raise setpoint  
p2235[0...n], 631
- BICO block, 930
- BICO interconnections search signal source  
p9484, 716
- BICO interconnections signal source search count  
r9485, 717
- BICO interconnections signal source search first  
index  
r9486, 717
- Bimetallic switch, 327
- Binectors, 931
- Block, 930
- BO: Connector-binector converter binector output  
r2094.0...15, 597  
r2095.0...15, 598
- BO: CU analog inputs status word  
r0751.0...11, 456
- BO: CU analog outputs status word  
r0785.0...2, 465
- BO: Fixed speed setpoint status  
r1025.0, 494
- BO: Master control active  
r0807.0, 470
- BO: PROFIdrive PZD state  
r2043.0...2, 585
- BO: PROFIdrive PZD1 receive bit-serial  
r2090.0...15, 595
- BO: PROFIdrive PZD2 receive bit-serial  
r2091.0...15, 596
- BO: PROFIdrive PZD3 receive bit-serial  
r2092.0...15, 596
- BO: PROFIdrive PZD4 receive bit-serial  
r2093.0...15, 597
- BO: RTC DTC1 output  
r8413.0...1, 700
- BO: RTC DTC2 output  
r8423.0...1, 702
- BO: RTC DTC3 output  
r8433.0...1, 704
- BO: STW1 from IOP in the manual mode  
r8540.0...15, 704
- BOP-2  
Menu, 925  
Symbols, 925
- Braking functions, 318
- Braking method, 317
- Bus termination, 94, 95
- Bypass, 354
- Bypass changeover source configuration  
p1267, 531
- Bypass configuration  
p1260, 529
- Bypass dead time  
p1262[0...n], 530
- Bypass delay time  
p1264, 531
- Bypass speed threshold  
p1265, 531
- Bypass switch monitoring time  
p1274[0...1], 533

## C

- Cable resistance, 295  
p0352[0...n], 426
- Cascade control, 287
- Catalog, 933
- Cavitation protection, 240

- Cavitation protection enable  
p29625[0...n], 751
- Cavitation protection threshold  
p29626[0...n], 752
- Cavitation protection time  
p29627[0...n], 752
- Change acknowledge mode fault number  
p2126[0...19], 606
- Change acknowledge mode mode  
p2127[0...19], 607
- Change fault response fault number  
p2100[0...19], 599
- Change fault response response  
p2101[0...19], 600
- Change message type message number  
p2118[0...19], 604
- Change message type type  
p2119[0...19], 605
- Change safety message type  
p3117, 662
- Characteristic
  - Additional, 298
  - Linear, 298, 307
  - parabolic, 298, 307
  - square-law, 298, 307
- Checklist  
PROFINET, 195
- CI: Active speed setpoint in the BOP/IOP manual mode  
p8543, 706
- CI: Comm IF USS PZD send word  
p2016[0...3], 583
- CI: Connector-binector converter signal source  
p2099[0...1], 599
- CI: CU analog outputs signal source  
p0771[0...2], 461
- CI: Current limit, variable  
p0641[0...n], 449
- CI: ESM setpoint technology controller  
p3884, 678
- CI: Free tec\_ctrl 0 actual value signal source  
p11064, 721
- CI: Free tec\_ctrl 0 limit maximum signal source  
p11097, 724
- CI: Free tec\_ctrl 0 limit minimum signal source  
p11098, 724
- CI: Free tec\_ctrl 0 limit offset signal source  
p11099, 725
- CI: Free tec\_ctrl 0 setpoint signal source  
p11053, 720
- CI: Free tec\_ctrl 1 actual value signal source  
p11164, 728
- CI: Free tec\_ctrl 1 limit maximum signal source  
p11197, 731
- CI: Free tec\_ctrl 1 limit minimum signal source  
p11198, 731
- CI: Free tec\_ctrl 1 limit offset signal source  
p11199, 732
- CI: Free tec\_ctrl 1 setpoint signal source  
p11153, 727
- CI: Free tec\_ctrl 2 actual value signal source  
p11264, 735
- CI: Free tec\_ctrl 2 limit maximum signal source  
p11297, 738
- CI: Free tec\_ctrl 2 limit minimum signal source  
p11298, 738
- CI: Free tec\_ctrl 2 limit offset signal source  
p11299, 739
- CI: Free tec\_ctrl 2 setpoint signal source  
p11253, 734
- CI: Load monitoring speed actual value  
p3230[0...n], 666
- CI: Main setpoint  
p1070[0...n], 501
- CI: Main setpoint scaling  
p1071[0...n], 501
- CI: Minimum speed signal source  
p1106[0...n], 508
- CI: Motorized potentiometer automatic setpoint  
p1042[0...n], 497
- CI: Motorized potentiometer setting value  
p1044[0...n], 498
- CI: PROFIdrive PZD send double word  
p2061[0...15], 588
- CI: PROFIdrive PZD send word  
p2051[0...16], 586
- CI: Ramp-down scaling input  
p29579[0...n], 747
- CI: Ramp-function generator ramp-down time scaling  
p1139[0...n], 514
- CI: Ramp-function generator ramp-up time scaling  
p1138[0...n], 513
- CI: Ramp-function generator setpoint input  
p29643, 754
- CI: Ramp-function generator setting value  
p1144[0...n], 516
- CI: Ramp-up scaling input  
p29578[0...n], 747
- CI: Skip speed scaling  
p1098[0...n], 507
- CI: Speed limit in negative direction of rotation  
p1088[0...n], 506
- CI: Speed limit in positive direction of rotation  
p1085[0...n], 505

- CI: Speed limit RFG negative direction of rotation  
p1052[0...n], 499
- CI: Speed limit RFG positive direction of rotation  
p1051[0...n], 499
- CI: Speed setpoint for messages/signals  
p2151[0...n], 613
- CI: Supplementary setp  
p1075[0...n], 502
- CI: Supplementary setpoint scaling  
p1076[0...n], 502
- CI: Technology controller actual value  
p2264[0...n], 636
- CI: Technology controller Kp adaptation input value  
signal source  
p2310, 643
- CI: Technology controller Kp adaptation scaling  
signal source  
p2315, 644
- CI: Technology controller limit offset  
p2299[0...n], 642
- CI: Technology controller maximum limit signal source  
p2297[0...n], 641
- CI: Technology controller minimum limit signal source  
p2298[0...n], 642
- CI: Technology controller output scaling  
p2296[0...n], 641
- CI: Technology controller precontrol signal  
p2289[0...n], 640
- CI: Technology controller setpoint 1  
p2253[0...n], 634
- CI: Technology controller setpoint 2  
p2254[0...n], 635
- CI: Technology controller Tn adaptation input value  
signal source  
p2317, 645
- CI: Torque limit lower  
p1523[0...n], 553
- CI: Torque limit lower scaling without offset  
p1554[0...n], 556
- CI: Torque limit upper  
p1522[0...n], 552
- CI: Torque limit upper scaling without offset  
p1552[0...n], 556
- Closed-loop cascade control configuration  
p2371, 650
- Closed-loop cascade control enable  
p2370[0...n], 649
- Closed-loop cascade control holding time switch-in  
speed  
p2385, 654
- Closed-loop cascade control holding time switch-out  
speed  
p2387, 655
- Closed-loop cascade control interlocking time  
p2377, 652
- Closed-loop cascade control max time for continuous  
operation  
p2381, 653
- Closed-loop cascade control mode motor selection  
p2372, 650
- Closed-loop cascade control motor switch-off delay  
p2386, 654
- Closed-loop cascade control motor switch-on delay  
p2384, 654
- Closed-loop cascade control operating hours  
p2380[0...2], 653
- Closed-loop cascade control operating time limit  
p2382, 653
- Closed-loop cascade control overcontrol threshold  
p2376, 652
- Closed-loop cascade control switch-in delay  
p2374, 651
- Closed-loop cascade control switch-in threshold  
p2373, 651
- Closed-loop cascade control switch-in/switch-out  
speed  
p2378, 652
- Closed-loop cascade control switch-out delay  
p2375, 652
- Closed-loop cascade control switch-out sequence  
p2383, 654
- CO/BO: 2/3 wire control control word  
r3333.0...3, 671
- CO/BO: Bypass control/status word  
r1261.0...11, 530
- CO/BO: Closed-loop cascade control status word  
r2379.0...7, 653
- CO/BO: Command Data Set CDS effective  
r0050.0...1, 388
- CO/BO: Command Data Set CDS selected  
r0836.0...1, 473
- CO/BO: Compound braking/DC quantity control  
status word  
r3859.0...1, 676
- CO/BO: Control word 1  
r0054.0...15, 391
- CO/BO: Control word faults/alarms  
r2138.7...15, 610
- CO/BO: Control word sequence control  
r0898.0...10, 481
- CO/BO: Control word setpoint channel  
r1198.0...15, 517



- CO/BO: CU digital inputs status  
r0722.0...12, 451
- CO/BO: CU digital inputs status inverted  
r0723.0...12, 451
- CO/BO: Data set changeover status word  
r0835.2...8, 473
- CO/BO: DC braking status word  
r1239.8...13, 525
- CO/BO: Drive coupling status word/control word  
r0863.0...1, 479
- CO/BO: Drive Data Set DDS effective  
r0051.0...1, 388
- CO/BO: Drive Data Set DDS selected  
r0837.0...1, 474
- CO/BO: ESM status word  
r3889.0...10, 678
- CO/BO: Extended setpoint channel selection output  
r29640.0...18, 753
- CO/BO: Faults/alarms trigger word  
r2129.0...15, 607
- CO/BO: Free tec\_ctrl 0 status word  
r11049.0...11, 720
- CO/BO: Free tec\_ctrl 1 status word  
r11149.0...11, 727
- CO/BO: Free tec\_ctrl 2 status word  
r11249.0...11, 734
- CO/BO: Gating unit status word 1  
r1838.0...15, 567
- CO/BO: Hibernation mode status words  
r2399.0...8, 658
- CO/BO: Limit switch status word  
r3344.0...5, 672
- CO/BO: Missing enable signal  
r0046.0...31, 385
- CO/BO: Mot\_temp status word faults/alarms  
r5389.0...8, 685
- CO/BO: Multi-pump control bypass command  
r29545, 745
- CO/BO: Multi-pump control feedback signal for  
contactor  
r29549, 745
- CO/BO: Multi-pump control service mode interlock  
manually  
p29542.0...3, 744
- CO/BO: Multi-pump control status word  
r29529.0...7, 741
- CO/BO: NAMUR message bit bar  
r3113.0...15, 661
- CO/BO: Pe energy-saving active/inactive  
r5613.0...1, 688
- CO/BO: PM330 digital inputs status  
r4022.0...3, 683
- CO/BO: PM330 digital inputs status inverted  
r4023.0...3, 683
- CO/BO: PolID diagnostics  
r1992.0...15, 579
- CO/BO: Safely remove memory card status  
r9401.0...3, 716
- CO/BO: Skip band status word  
r1099.0, 507
- CO/BO: Status word 1  
r0052.0...15, 388
- CO/BO: Status word 2  
r0053.0...11, 389, 390
- CO/BO: Status word faults/alarms 1  
r2139.0...15, 610
- CO/BO: Status word faults/alarms 2  
r2135.12...15, 609
- CO/BO: Status word monitoring 1  
r2197.0...13, 623
- CO/BO: Status word monitoring 2  
r2198.4...12, 624
- CO/BO: Status word monitoring 3  
r2199.0...5, 625
- CO/BO: Status word sequence control  
r0899.0...11, 481
- CO/BO: Status word speed controller  
r1407.0...23, 547
- CO/BO: Status word, closed-loop control  
r0056.0...15, 393
- CO/BO: Status word: application  
r29629, 752
- CO/BO: Status word:command  
r29659, 755
- CO/BO: Supplementary control word  
r0055.0...15, 391, 392
- CO/BO: Technology controller fixed value selection  
status word  
r2225.0, 630
- CO/BO: Technology controller status word  
r2349.0...13, 648
- CO/BO: Write protection/know-how protection status  
r7760.0...12, 690
- CO: Absolute actual current smoothed  
r0027, 380
- CO: Absolute current actual value  
r0068[0...1], 395
- CO: Accelerating torque  
r1518[0...1], 551
- CO: Active power actual value  
r0082[0...2], 398
- CO: Active power actual value smoothed  
r0032, 380

- CO: Actual alarm code  
r2132, 609
- CO: Actual component number  
r3132, 665
- CO: Actual DC link voltage  
r0070, 396
- CO: Actual fault code  
r2131, 608
- CO: Actual fault value  
r3131, 665
- CO: Actual power factor  
r0087, 398
- CO: Actual slip compensation  
r1337, 543
- CO: Actual speed  
r0063[0...2], 394
- CO: Actual speed smoothed  
r0021, 378
- CO: Actual speed smoothed signals  
r2169, 617
- CO: Counter alarm buffer changes  
r2121, 605
- CO: Counter for fault buffer changes  
r0944, 482
- CO: CU analog inputs actual value in percent  
r0755[0...3], 457
- CO: CU analog inputs input voltage/current actual  
r0752[0...3], 456
- CO: Current actual value field-generating  
r0076, 397
- CO: Current actual value torque-generating  
r0078, 397
- CO: Current setpoint field-generating  
r0075, 396
- CO: Current setpoint torque-generating  
r0077, 397
- CO: DC link voltage smoothed  
r0026, 379
- CO: Energy display  
r0039[0...2], 383
- CO: Extended setpoint channel setpoint output  
r29641, 754
- CO: Fixed speed setpoint 1  
p1001[0...n], 489
- CO: Fixed speed setpoint 10  
p1010[0...n], 491
- CO: Fixed speed setpoint 11  
p1011[0...n], 491
- CO: Fixed speed setpoint 12  
p1012[0...n], 491
- CO: Fixed speed setpoint 13  
p1013[0...n], 492
- CO: Fixed speed setpoint 14  
p1014[0...n], 492
- CO: Fixed speed setpoint 15  
p1015[0...n], 492
- CO: Fixed speed setpoint 2  
p1002[0...n], 489
- CO: Fixed speed setpoint 3  
p1003[0...n], 489
- CO: Fixed speed setpoint 4  
p1004[0...n], 489
- CO: Fixed speed setpoint 5  
p1005[0...n], 490
- CO: Fixed speed setpoint 6  
p1006[0...n], 490
- CO: Fixed speed setpoint 7  
p1007[0...n], 490
- CO: Fixed speed setpoint 8  
p1008[0...n], 490
- CO: Fixed speed setpoint 9  
p1009[0...n], 491
- CO: Fixed speed setpoint effective  
r1024, 494
- CO: Fixed value 1 [%]  
p2900[0...n], 658
- CO: Fixed value 2 [%]  
p2901[0...n], 659
- CO: Fixed value M [Nm]  
p2930[0...n], 659
- CO: Fixed values [%]  
r2902[0...14], 659
- CO: Flux setpoint  
p1570[0...n], 556, 557
- CO: Free tec\_ctrl 0 actual value after limiter  
r11072, 722
- CO: Free tec\_ctrl 0 limit maximum  
p11091, 723
- CO: Free tec\_ctrl 0 limit minimum  
p11092, 723
- CO: Free tec\_ctrl 0 output signal  
r11094, 724
- CO: Free tec\_ctrl 0 setpoint after ramp-function  
generator  
r11060, 721
- CO: Free tec\_ctrl 0 system deviation  
r11073, 722
- CO: Free tec\_ctrl 1 actual value after limiter  
r11172, 729
- CO: Free tec\_ctrl 1 limit maximum  
p11191, 730
- CO: Free tec\_ctrl 1 limit minimum  
p11192, 730

- CO: Free tec\_ctrl 1 output signal  
r11194, 731
- CO: Free tec\_ctrl 1 setpoint after ramp-function generator  
r11160, 728
- CO: Free tec\_ctrl 1 system deviation  
r11173, 729
- CO: Free tec\_ctrl 2 actual value after limiter  
r11272, 736
- CO: Free tec\_ctrl 2 limit maximum  
p11291, 737
- CO: Free tec\_ctrl 2 limit minimum  
p11292, 737
- CO: Free tec\_ctrl 2 output signal  
r11294, 738
- CO: Free tec\_ctrl 2 setpoint after ramp-function generator  
r11260, 735
- CO: Free tec\_ctrl 2 system deviation  
r11273, 736
- CO: Hibernation mode output speed actual  
r2397[0...1], 657
- CO: I\_max controller frequency output  
r1343, 544
- CO: Lower effective torque limit  
r1539, 555
- CO: Main setpoint effective  
r1073, 501
- CO: Maximum power unit output current  
r0289, 409
- CO: Moment of inertia total, scaled  
r1493, 550
- CO: Mot. potentiometer speed setp. in front of ramp-fct. gen.  
r1045, 498
- CO: Motor temperature  
r0035, 381
- CO: Motor utilization thermal  
r0034, 381
- CO: Motorized potentiometer setpoint after ramp-function generator  
r1050, 499
- CO: Output current maximum  
r0067, 395
- CO: Output frequency  
r0066, 395
- CO: Output voltage  
r0072, 396
- CO: Output voltage smoothed  
r0025, 379
- CO: Power unit overload I2t  
r0036, 382
- CO: Power unit temperatures  
r0037[0...19], 382
- CO: Process energy display  
r0042[0...2], 384
- CO: PROFIdrive PZD receive double word  
r2060[0...10], 587
- CO: PROFIdrive PZD receive word  
r2050[0...11], 585
- CO: Pulse frequency  
r1801[0...1], 565
- CO: Ramp-down scaling output  
r29577, 747
- CO: Ramp-function generator acceleration  
r1149, 516
- CO: Ramp-function generator setpoint at the input  
r1119, 509
- CO: Ramp-up scaling output  
r29576, 746
- CO: Send binector-connector converter status word  
r2089[0...4], 594
- CO: Setpoint after the direction limiting  
r1114, 509
- CO: Speed controller I torque output  
r1482, 550
- CO: Speed controller setpoint sum  
r1170, 516
- CO: Speed controller speed setpoint  
r1438, 548
- CO: Speed controller system deviation  
r0064, 394
- CO: Speed limit in negative direction of rotation  
p1086[0...n], 505
- CO: Speed limit in positive direction of rotation  
p1083[0...n], 505
- CO: Speed limit negative effective  
r1087, 506
- CO: Speed limit positive effective  
r1084, 505
- CO: Speed setpoint after the filter  
r0062, 394
- CO: Speed setpoint before the setpoint filter  
r0060, 393
- CO: Speed setpoint from the IOP in the manual mode  
r8541, 705
- CO: Supplementary setpoint effective  
r1077, 502
- CO: Technology controller actual value after filter  
r2266, 637
- CO: Technology controller actual value scaled  
r2272, 638
- CO: Technology controller fixed value 1  
p2201[0...n], 625

- CO: Technology controller fixed value 10  
p2210[0...n], 627
- CO: Technology controller fixed value 11  
p2211[0...n], 628
- CO: Technology controller fixed value 12  
p2212[0...n], 628
- CO: Technology controller fixed value 13  
p2213[0...n], 628
- CO: Technology controller fixed value 14  
p2214[0...n], 628
- CO: Technology controller fixed value 15  
p2215[0...n], 629
- CO: Technology controller fixed value 2  
p2202[0...n], 625
- CO: Technology controller fixed value 3  
p2203[0...n], 626
- CO: Technology controller fixed value 4  
p2204[0...n], 626
- CO: Technology controller fixed value 5  
p2205[0...n], 626
- CO: Technology controller fixed value 6  
p2206[0...n], 626
- CO: Technology controller fixed value 7  
p2207[0...n], 627
- CO: Technology controller fixed value 8  
p2208[0...n], 627
- CO: Technology controller fixed value 9  
p2209[0...n], 627
- CO: Technology controller fixed value effective  
r2224, 630
- CO: Technology controller last speed setpoint  
(smoothed)  
r2344, 647
- CO: Technology controller maximum limiting  
p2291, 640
- CO: Technology controller minimum limiting  
p2292, 640
- CO: Technology controller mot. potentiometer  
setpoint before RFG  
r2245, 632
- CO: Technology controller motorized potentiometer  
setpoint after RFG  
r2250, 633
- CO: Technology controller output scaling  
p2295, 641
- CO: Technology controller output signal  
r2294, 641
- CO: Technology controller setpoint after filter  
r2262, 636
- CO: Technology controller setpoint after ramp-  
function generator  
r2260, 636
- CO: Technology controller system deviation  
r2273, 639
- CO: Technology controller Tn adaptation output  
r2322, 646
- CO: Technology controller, Kp adaptation output  
r2316, 645
- CO: Torque actual value  
r0080[0...1], 398
- CO: Torque limit for speed controller output  
r1547[0...1], 555
- CO: Torque limit lower  
p1521[0...n], 552
- CO: Torque limit lower scaling  
p1525[0...n], 553
- CO: Torque limit lower without offset  
r1527, 554
- CO: Torque limit upper  
p1520[0...n], 552
- CO: Torque limit upper without offset  
r1526, 554
- CO: Torque limit upper/motoring scaling  
p1524[0...n], 553
- CO: Torque setpoint  
r0079, 397
- CO: Torque setpoint before supplementary torque  
r1508, 551
- CO: Total flux setpoint  
r1598, 559
- CO: Total setpoint effective  
r1078, 502
- CO: Upper effective torque limit  
r1538, 555
- CO: Vdc controller output  
r1258, 529
- CO: Vdc controller output (U/f)  
r1298, 537
- Comm IF address  
p2011, 582
- Comm IF baud rate  
p2010, 582
- Command data set, 214
- Command data set (CDS), 214
- Commissioning  
Guidelines, 123
- Communication  
Acyclic, 189
- Completion of quick commissioning  
p3900, 678
- Component alarm  
r3121[0...63], 663
- Component fault  
r3120[0...63], 663

- Compound braking, 321, 322
  - Compound braking current
    - p3856[0...n], 675
  - Compressor, 134, 141
  - Condensation protection, 238
  - Condensation protection current
    - p29624[0...n], 751
  - Connectors, 931
  - Control terminals, 99
  - Control Unit firmware version
    - r0018, 378
  - Control word
    - Control word 3, 179
    - Control word 1, 177
  - Control word 3 (STW3), 179
  - Converter
    - Update, 894
  - Cooling, 53
  - Copy Command Data Set CDS
    - p0809[0...2], 471
  - Copy Drive Data Set DDS
    - p0819[0...2], 472
  - CU analog inputs characteristic value x1
    - p0757[0...3], 458
  - CU analog inputs characteristic value x2
    - p0759[0...3], 459
  - CU analog inputs characteristic value y1
    - p0758[0...3], 459
  - CU analog inputs characteristic value y2
    - p0760[0...3], 460
  - CU analog inputs dead zone
    - p0764[0...3], 461
  - CU analog inputs simulation mode
    - p0797[0...3], 467
  - CU analog inputs simulation mode setpoint
    - p0798[0...3], 467
  - CU analog inputs smoothing time constant
    - p0753[0...3], 457
  - CU analog inputs type
    - p0756[0...3], 457
  - CU analog inputs wire breakage monitoring delay time
    - p0762[0...3], 460
  - CU analog inputs wire breakage monitoring response threshold
    - p0761[0...3], 460
  - CU analog outputs activate absolute value generation
    - p0775[0...2], 462
  - CU analog outputs characteristic value x1
    - p0777[0...2], 463
  - CU analog outputs characteristic value x2
    - p0779[0...2], 464
  - CU analog outputs characteristic value y1
    - p0778[0...2], 464
  - CU analog outputs characteristic value y2
    - p0780[0...2], 465
  - CU analog outputs output value currently referred
    - r0772[0...2], 462
  - CU analog outputs output voltage/current actual
    - r0774[0...2], 462
  - CU analog outputs smoothing time constant
    - p0773[0...2], 462
  - CU analog outputs type
    - p0776[0...2], 463
  - CU detection via LED
    - p0124[0...n], 400
  - CU digital inputs debounce time
    - p0724, 452
  - CU digital inputs simulation mode
    - p0795, 466
  - CU digital inputs simulation mode setpoint
    - p0796, 466
  - CU digital inputs terminal actual value
    - r0721, 450
  - CU digital outputs status
    - r0747, 455
  - CU invert digital outputs
    - p0748, 455
  - CU number of inputs and outputs
    - r0720[0...4], 450
  - Current injection ramp time
    - p1601[0...n], 560
  - Current input, 165
  - Current limit
    - p0640[0...n], 448
  - Current limit excitation induction motor
    - p0644[0...n], 449
  - Current limit torque-generating total
    - r1533, 555
  - Current setpoint smoothing time
    - p1616[0...n], 561
  - Current threshold value
    - p2170[0...n], 617
  - Current threshold value reached delay time
    - p2171[0...n], 617
  - Cyclic communication, 187
- D**
- Data backup, 759
    - Data transfer, 763, 766
  - Data transfer start
    - p0804, 468

- Data transfer: device memory as source/target
    - p0803, 468
  - Data transfer: memory card as source/target
    - p0802, 468
  - Date, 292
  - Daylight saving time, 293
  - DC braking, 179, 319, 320
  - DC braking braking current
    - p1232[0...n], 524
  - DC braking configuration
    - p1231[0...n], 523
  - DC braking time
    - p1233[0...n], 525
  - DC link voltage, 331
  - DC link voltage comparison delay time
    - p2173[0...n], 617
  - DC link voltage overvoltage threshold
    - r0297, 411
  - DC link voltage threshold value
    - p2172[0...n], 617
  - DC link voltage undervoltage threshold
    - r0296, 411
  - DC quantity controller configuration
    - p3855[0...n], 674
  - DC quantity controller integral time
    - p3858[0...n], 675
  - DC quantity controller P gain
    - p3857[0...n], 675
  - DC-link overvoltage, 331
  - Deadband, 169
  - Debounce delay time
    - p1263, 531
  - Delta connection, 93
  - Delta connection ( $\Delta$ ), 125, 126
  - Deragging, 241
  - Deragging forward speed
    - p29592[0...n], 748
  - Deragging forward time
    - p29596[0...n], 749
  - Deragging mode
    - p29590[0...n], 747
  - Deragging ramp down time
    - p29595[0...n], 749
  - Deragging ramp up time
    - p29594[0...n], 748
  - Deragging reverse speed
    - p29593[0...n], 748
  - Deragging reverse time
    - p29597[0...n], 749
  - Device identification
    - r0964[0...6], 484
  - DI selection for ON/OFF2
    - p29650[0...n], 754
  - Diagnostic attribute alarm
    - r3123[0...63], 664
  - Diagnostic attribute fault
    - r3122[0...63], 663
  - Digital input, 99
  - Digital output, 99
    - Function, 161, 166, 171
  - Dimension drawings, 58, 61
  - DIP switch
    - Analog input, 165
  - Direction of rotation, 257
  - Display values smoothing time constant
    - p0045, 385
  - Download, 763
  - Drive commissioning parameter filter
    - p0010, 377
  - Drive control, 147
  - Drive Data Set, DDS, 370
  - Drive data sets, 370
  - Drive filter type motor side
    - p0230, 405, 406
  - Drive operating display
    - r0002, 376
  - Drive unit line supply voltage
    - p0210, 405
  - Drive unit reset
    - p0972, 487
  - Drive unit status word
    - r3974, 682
  - DS 47, 189
  - DTC (Digital Time Clock), 294
  - Dual ramp, 267
- ## E
- Efficiency optimization
    - p1580[0...n], 558, 559
  - Efficiency optimization 2 maximum flux limit value
    - p3316[0...n], 667
  - Efficiency optimization 2 minimum flux limit value
    - p3315[0...n], 667
  - Efficiency optimization 2 optimum flux
    - r3313, 667
  - EMC, 48
  - EMERGENCY STOP, 220
  - EMERGENCY SWITCHING OFF, 220
  - EN 60204-1, 220
  - EN 61800-5-2, 219
  - Enable PID autotuning
    - p2350, 648

- Energy consumption saved
  - r0041, 384
- Energy-saving display, 368
- ESM, 347
- ESM setpoint source
  - p3881, 676
- ESM setpoint source alternative
  - p3882, 677
- Essential service mode, 347
- Ethernet/IP, 194
- Ethernet/IP ODVA speed scaling
  - p8982, 714
- Ethernet/IP ODVA STOP mode
  - p8981, 713
- Ethernet/IP ODVA torque scaling
  - p8983, 714
- Ethernet/IP profile
  - p8980, 713
- Extending the telegram, 188
- External fault 3 switch-on delay
  - p3110, 660
  
- F**
- Factory assignment, 99
- Factory settings
  - Restoring the, 145
- Fan, 134, 141
- Fan run-on time
  - p0295, 411
- Fans, 324, 869
- Fault, 292, 777, 785
  - Acknowledge, 785, 786
- Fault buffer, 292, 785
- Fault case, 787
- Fault cases counter
  - p0952, 484
- Fault code, 785
  - r0945[0...63], 483
- Fault code list
  - r0946[0...65534], 483
- Fault history, 786
- Fault number
  - r0947[0...63], 483
- Fault time, 292, 785
  - received, 785
  - removed, 785
- Fault time received in days
  - r2130[0...63], 608
- Fault time received in milliseconds
  - r0948[0...63], 483
  
- Fault time removed in days
  - r2136[0...63], 610
- Fault time removed in milliseconds
  - r2109[0...63], 602
- Fault value, 785
  - r0949[0...63], 484
- Fault value for float values
  - r2133[0...63], 609
- Faults and alarms
  - Overview, 788
- Faults/alarms trigger selection
  - p2128[0...15], 607
- FCC, 296
- FCC (Flux Current Control), 298
- Field bus interface protocol selection
  - p2030, 583
- Field weakening, 93
- Field weakening controller integral-action time
  - p1596[0...n], 559
- Fieldbus interfaces, 94, 95
- Filter time constant Vdc correction
  - p1806[0...n], 566
- Firmware
  - Update, 894
- Firmware check status
  - r9926, 717
- Firmware downgrade, 891
- Firmware file incorrect
  - r9925[0...99], 717
- Fixed speed setpoint select mode
  - p1016, 492
- Flow control, 269
- Flow meter calculated flow
  - r29633, 753
- Flow meter pump flow
  - p29632[0...4], 753
- Flow meter pump power
  - p29631[0...4], 753
- Fluid flow machine power point 1
  - p3320[0...n], 667
- Fluid flow machine power point 2
  - p3322[0...n], 668
- Fluid flow machine power point 3
  - p3324[0...n], 669
- Fluid flow machine power point 4
  - p3326[0...n], 669
- Fluid flow machine power point 5
  - p3328[0...n], 670
- Fluid flow machine speed point 1
  - p3321[0...n], 668
- Fluid flow machine speed point 2
  - p3323[0...n], 668

- Fluid flow machine speed point 3  
p3325[0...n], 669
- Fluid flow machine speed point 4  
p3327[0...n], 670
- Fluid flow machine speed point 5  
p3329[0...n], 670
- Flux control configuration  
p1401[0...n], 546
- Flux current control, 296
- Flux model value display  
r2969[0...6], 660
- Flux reduction factor  
p1581[0...n], 559
- Flux reduction flux build-up time constant  
p1579[0...n], 558
- Flux reduction flux decrease time constant  
p1578[0...n], 558
- Flux reduction torque factor transition value  
r1566[0...n], 556
- Flux setpoint smoothing time  
p1582[0...n], 559
- Flying restart, 340
- Flying restart maximum frequency for the inhibited  
direction  
p1271[0...n], 532
- Flying restart operating mode  
p1200[0...n], 517
- Flying restart search current  
p1202[0...n], 518
- Flying restart search rate factor  
p1203[0...n], 519
- Formatting, 760
- Forming activation/duration  
p3380, 673
- Forming remaining time  
r3381, 673
- Forming status word  
r3382, 674
- Forming the DC link capacitors, 127
- Free tec\_ctrl 0 actual value inversion  
p11071, 722
- Free tec\_ctrl 0 actual value lower limit  
p11068, 722
- Free tec\_ctrl 0 actual value smoothing time constant  
p11065, 721
- Free tec\_ctrl 0 actual value upper limit  
p11067, 722
- Free tec\_ctrl 0 differentiation time constant  
p11074, 723
- Free tec\_ctrl 0 integral time  
p11085, 723
- Free tec\_ctrl 0 limit ramp-up/ramp-down time  
p11093, 724
- Free tec\_ctrl 0 proportional gain  
p11080, 723
- Free tec\_ctrl 0 sampling time  
p11028, 719
- Free tec\_ctrl 0 setpoint ramp-down time  
p11058, 720
- Free tec\_ctrl 0 setpoint ramp-up time  
p11057, 720
- Free tec\_ctrl 0 system deviation inversion  
p11063, 721
- Free tec\_ctrl 0 unit reference quantity  
p11027, 719
- Free tec\_ctrl 0 unit selection  
p11026, 718
- Free tec\_ctrl 1 actual value inversion  
p11171, 729
- Free tec\_ctrl 1 actual value lower limit  
p11168, 729
- Free tec\_ctrl 1 actual value smoothing time constant  
p11165, 728
- Free tec\_ctrl 1 actual value upper limit  
p11167, 729
- Free tec\_ctrl 1 differentiation time constant  
p11174, 730
- Free tec\_ctrl 1 integral time  
p11185, 730
- Free tec\_ctrl 1 limit ramp-up/ramp-down time  
p11193, 731
- Free tec\_ctrl 1 proportional gain  
p11180, 730
- Free tec\_ctrl 1 sampling time  
p11128, 726
- Free tec\_ctrl 1 setpoint ramp-down time  
p11158, 727
- Free tec\_ctrl 1 setpoint ramp-up time  
p11157, 727
- Free tec\_ctrl 1 system deviation inversion  
p11163, 728
- Free tec\_ctrl 1 unit reference quantity  
p11127, 726
- Free tec\_ctrl 1 unit selection  
p11126, 725
- Free tec\_ctrl 2 actual value inversion  
p11271, 736
- Free tec\_ctrl 2 actual value lower limit  
p11268, 736
- Free tec\_ctrl 2 actual value smoothing time constant  
p11265, 735
- Free tec\_ctrl 2 actual value upper limit  
p11267, 736



Free tec\_ctrl 2 differentiation time constant  
p11274, 737

Free tec\_ctrl 2 integral time  
p11285, 737

Free tec\_ctrl 2 limit ramp-up/ramp-down time  
p11293, 738

Free tec\_ctrl 2 proportional gain  
p11280, 737

Free tec\_ctrl 2 sampling time  
p11228, 733

Free tec\_ctrl 2 setpoint ramp-down time  
p11258, 734

Free tec\_ctrl 2 setpoint ramp-up time  
p11257, 734

Free tec\_ctrl 2 system deviation inversion  
p11263, 735

Free tec\_ctrl 2 unit reference quantity  
p11227, 733

Free tec\_ctrl 2 unit selection  
p11226, 732

Frost protection, 237

Frost protection speed  
p29623[0...n], 751

Functions  
BOP-2, 925

## G

Gain resonance damping for encoderless closed-loop control  
p1740[0...n], 561

Generator operation, 317

Getting Started, 932

Ground fault monitoring thresholds  
p0287[0...1], 409

## H

Hardware sampling times still assignable  
r7903, 695

Hibernation mode boost speed  
p2395[0...n], 656

Hibernation mode boost time period  
p2394[0...n], 656

Hibernation mode delay time  
p2391[0...n], 655

Hibernation mode max. shutdown time  
p2396[0...n], 657

Hibernation mode operating type  
p2398, 657

Hibernation mode restart speed relative w/o techn controller  
p2393[0...n], 656

Hibernation mode restart value with technology controller  
p2392, 655

Hotline, 934

Hysteresis speed 1  
p2142[0...n], 611

Hysteresis speed 2  
p2140[0...n], 611

Hysteresis speed 3  
p2150[0...n], 613

Hysteresis speed 4  
p2164[0...n], 615

Hysteresis speed  $n\_act > n\_max$   
p2162[0...n], 615

## I

I\_max controller, 323

I\_max controller voltage output  
r1344, 544

I\_max frequency controller integral time  
p1341[0...n], 544

I\_max frequency controller proportional gain  
p1340[0...n], 543

I\_max voltage controller integral time  
p1346[0...n], 545

I\_max voltage controller proportional gain  
p1345[0...n], 544

i2t monitoring, 326

I2t motor model thermal time constant  
p0611[0...n], 442

Identification and Maintenance 1  
p8806[0...53], 707

Identification and Maintenance 2  
p8807[0...15], 707

Identification and Maintenance 3  
p8808[0...53], 708

Identification and Maintenance 4  
p8809[0...53], 708

Identification and maintenance 4 configuration  
p8805, 707

Identification final display  
r3925[0...n], 679

Identification stator resistance after restart  
p0621[0...n], 445

IEC/NEMA Standards  
p0100, 399

IND (page index), 184

Industry Mall, 933

Inhibit automatic reference value calculation  
p0573, 438  
Installation, 57  
Interfaces, 94  
Internal power unit resistance  
r0238, 408  
Interpolator clock cycle for speed setpoints  
p1079, 502  
Invert binector-connector converter status word  
p2088[0...4], 594  
Inverter connector-binector converter binector output  
p2098[0...1], 598  
IO extension module status  
r0719, 450  
IOP speed unit  
p8552, 706

## J

Jog 1 speed setpoint  
p1058[0...n], 500  
Jog 2 speed setpoint  
p1059[0...n], 500  
JOG function, 212

## K

Keep-running operation enable  
p29630, 752  
KHP configuration  
p7765, 691  
KHP Control Unit reference serial number  
p7759[0...19], 689  
KHP Control Unit serial number  
r7758[0...19], 689  
KHP memory card reference serial number  
p7769[0...20], 693  
KHP OEM exception list  
p7764[0...n], 691  
KHP OEM exception list number of indices for p7764  
p7763, 691  
KHP password confirmation  
p7768[0...29], 693  
KHP password input  
p7766[0...29], 692  
KHP password new  
p7767[0...29], 693  
Kinetic buffering, 345  
Know-how protection, 760, 773  
KTY84 sensor, 327

## L

LED  
BF, 778, 779  
LNK, 778  
RDY, 778  
LED (light emitting diode), 777  
Level control, 269  
Line contactor, 219  
Line contactor monitoring time  
p0861, 479  
Line dip, 345  
Linear characteristic, 298, 307  
List of faults and alarms, 788  
LNK (PROFINET Link), 778  
Load monitoring configuration  
p2193[0...n], 623  
Load monitoring delay time  
p2192[0...n], 623  
Load monitoring response  
p2181[0...n], 619  
Load monitoring speed deviation  
p3231[0...n], 666  
Load monitoring speed threshold value 1  
p2182[0...n], 620  
Load monitoring speed threshold value 2  
p2183[0...n], 620  
Load monitoring speed threshold value 3  
p2184[0...n], 620  
Load monitoring stall monitoring torque threshold  
p2168[0...n], 616  
Load monitoring stall monitoring upper threshold  
p2165[0...n], 615  
Load monitoring torque threshold 1 lower  
p2186[0...n], 621  
Load monitoring torque threshold 1 upper  
p2185[0...n], 621  
Load monitoring torque threshold 2 lower  
p2188[0...n], 622  
Load monitoring torque threshold 2 upper  
p2187[0...n], 621  
Load monitoring torque threshold 3 lower  
p2190[0...n], 622  
Load monitoring torque threshold 3 upper  
p2189[0...n], 622  
Load monitoring torque threshold no load  
p2191[0...n], 622

**M**

- Macro drive object
  - r8570[0...39], 706
- Macro drive unit
  - p0015, 377
- Macro execution actual
  - r8585, 706
- Manual mode, 214, 215
- Master control control word effective
  - r2032, 583
- Master control mode selection
  - p3985, 682
- Maximum cable length
  - PROFINET, 120
- Maximum current controller, 323
- Maximum modulation depth
  - p1803[0...n], 566
- Maximum motor current
  - p0323[0...n], 419
- Maximum motor speed
  - p0322[0...n], 419
- Maximum output voltage
  - r0071, 396
- Maximum speed, 130, 257
  - p1082[0...n], 504
- Maximum speed scaling
  - p1081, 503
- Memory card, 760
- Memory card serial number
  - r7843[0...20], 694
- Memory card/device memory firmware version
  - r7844[0...2], 695
- Menu
  - BOP-2, 925
  - Operator panel, 925
- Minimum speed, 130, 257, 262
  - p1080[0...n], 503
- Modular Safety System, 113
- Modulator configuration
  - p1810, 567
- Modulator mode
  - p1802[0...n], 566
- Monitoring configuration
  - p2149[0...n], 613
- MOP (motorized potentiometer), 249
- Mot\_temp\_mod 1 (I2t) fault threshold
  - p0615[0...n], 444
- Mot\_temp\_mod 1/2/sensor threshold and temperature value
  - p0605[0...n], 441
- Mot\_temp\_mod 1/3 alarm threshold
  - p5390[0...n], 686
- Mot\_temp\_mod 1/3 ambient temperature
  - p0613[0...n], 443
- Mot\_temp\_mod 1/3 boost factor at standstill
  - p5350[0...n], 685
- Mot\_temp\_mod 1/3 fault threshold
  - p5391[0...n], 686
- Mot\_temp\_mod 2/sensor alarm threshold
  - p0604[0...n], 440
- Mot\_temp\_mod activation
  - p0612[0...n], 442
- Mot\_temp\_mod stator winding temperature
  - r0632[0...n], 448
- MotID (motor data identification), 136, 138, 142
- Motor ambient temperature during commissioning
  - p0625[0...n], 447
- Motor blocked delay time
  - p2177[0...n], 618
- Motor blocked speed threshold
  - p2175[0...n], 618
- Motor changeover motor number
  - p0826[0...n], 472
- Motor code, 126
- Motor code number selection
  - p0301[0...n], 414
- Motor configuration
  - p0133[0...n], 400
- Motor control, 148
- Motor cooling type
  - p0335[0...n], 422
- Motor data, 125
  - Identify, 136, 138, 142, 316
  - Measure, 136, 138, 142
- Motor data identification and rotating measurement
  - p1900, 568, 569
- Motor data identification and speed controller optimization
  - r0047, 387
- Motor data identification control word
  - p1909[0...n], 571, 572
  - r3927[0...n], 680
- Motor data identification selection
  - p1910, 573, 574
- Motor de-excitation time
  - p0347[0...n], 425
- Motor excitation build-up time
  - p0346[0...n], 424
- Motor excitation time for Rs\_ident after switching on again
  - p0622[0...n], 446
- Motor holding brake, 219

- Motor magnetizing inductance
  - p0360[0...n], 428
- Motor model adaptation configuration
  - p1780[0...n], 564
- Motor model changeover speed encoderless operation
  - p1755[0...n], 563
- Motor model changeover speed hysteresis encoderless operation
  - p1756, 564
- Motor model configuration
  - p1750[0...n], 562
- Motor model error signal stall detection
  - r1746, 561
- Motor model error threshold stall detection
  - p1745[0...n], 561
- Motor moment of inertia
  - p0341[0...n], 423
- Motor operating hours maintenance interval
  - p0651[0...n], 449
- Motor overtemperature response
  - p0610[0...n], 441
- Motor overtemperature, stator winding
  - p0627[0...n], 447
- Motor pole pair number, actual (or calculated)
  - r0313[0...n], 418
- Motor pole position identification current
  - p0329[0...n], 420
- Motor pole position identification current 1st phase
  - p0325[0...n], 419
- Motor rated magnetizing current/short-circuit current
  - p0320[0...n], 418
- Motor reactor in series number
  - p0235, 408
- Motor rotor leakage inductance
  - p0358[0...n], 427
- Motor rotor resistance cold
  - p0354[0...n], 426
- Motor rotor time constant / damping time constant d axis
  - r0384[0...n], 428
- Motor stalled delay time
  - p2178[0...n], 618
- Motor standard, 216
- Motor stator inductance d axis
  - p0357[0...n], 427
- Motor stator leakage inductance
  - p0356[0...n], 427
- Motor stator resistance cold
  - p0350[0...n], 425
- Motor temperature sensor, 99
  - Motor temperature sensor type
    - p0601[0...n], 440
  - Motor torque constant
    - p0316[0...n], 418
  - Motor type selection
    - p0300[0...n], 411, 413
  - Motor weight (for the thermal motor model)
    - p0344[0...n], 424
  - Motorized potentiometer, 249
    - Motorized potentiometer configuration
      - p1030[0...n], 495
    - Motorized potentiometer maximum speed
      - p1037[0...n], 496
    - Motorized potentiometer minimum speed
      - p1038[0...n], 496
    - Motorized potentiometer ramp-down time
      - p1048[0...n], 498
    - Motorized potentiometer ramp-up time
      - p1047[0...n], 498
    - Motorized potentiometer starting value
      - p1040[0...n], 497
  - Multi-pump control, 222
    - Pump switch-in, 224
    - Pump switch-out, 226
    - Pump switchover, 232
    - Service mode, 234
    - Stop mode, 229
  - Multi-pump control absolute operating hours
    - p29530[0...3], 742
  - Multi-pump control continuous operating hours
    - p29547[0...3], 745
  - Multi-pump control deviation threshold
    - p29546, 745
  - Multi-pump control disconnection lockout time
    - p29537, 743
  - Multi-pump control enable
    - p29520, 739
  - Multi-pump control index of motors under repair
    - r29544, 744
  - Multi-pump control interlocking time
    - p29527, 741
  - Multi-pump control maximum time for continuous operation
    - p29531, 742
  - Multi-pump control motor configuration
    - p29521, 739
  - Multi-pump control motor selection mode
    - p29522, 740
  - Multi-pump control overcontrol threshold
    - p29526, 741
  - Multi-pump control pump switchover enable
    - p29539, 743

Multi-pump control service mode enable  
p29540, 743

Multi-pump control switch-in delay  
p29524, 740

Multi-pump control switch-in threshold  
p29523, 740

Multi-pump control switch-off sequence  
p29533, 742

Multi-pump control switch-out delay  
p29525, 740

Multi-pump control switch-out speed offset  
p29528, 741

Multi-pump control variable-speed motor  
r29538, 743

## N

Nominal motor starting time  
r0345[0...n], 424

Number of Command Data Sets (CDS)  
p0170, 400

Number of deragging cycles  
p29598[0...n], 749

Number of Drive Data Sets (DDS)  
p0180, 401

Number of motors connected in parallel  
p0306[0...n], 415

Number of parameters  
r3986, 682

NVRAM data backup/import/delete  
p7775, 693

## O

OA version  
r29018[0...1], 739

Off delay  $n_{act} = n_{set}$   
p2166[0...n], 616

OFF3 final rounding-off time  
p1137[0...n], 513

OFF3 initial rounding-off time  
p1136[0...n], 513

OFF3 ramp-down time, 266  
p1135[0...n], 512, 513

On delay comparison value reached  
p2156[0...n], 614

Open-loop/closed-loop control operating mode  
p1300[0...n], 537, 538

Operating hours counter power unit fan  
p0251[0...n], 408

Operating hours counter power unit fan inside the converter  
p0254[0...n], 409

Operating instruction, 23

Operating Instructions, 932

Operation, 150

Operator panel  
BOP-2, 925  
Menu, 925

Optimizing the closed-loop speed controller, 316

Optimum motor load angle  
p0327[0...n], 420

Options for electrical cabinets  
p3931, 681

Output frequency smoothed  
r0024, 379

Output load detection delay time  
p2180[0...n], 619

Output load identification current limit  
p2179[0...n], 619

Output reactor, 295

Overload, 323

Overvoltage, 331

Overvoltage protection, 118

## P

Parabolic characteristic, 298, 307

Parameter channel, 182

Parameter channel"; "IND, 184

Parameter index, 184

Parameter number, 184, 928

Parameter value, 189, 928

Parameter write inhibit status  
r3996[0...1], 683

Parameters  
Overview, 373, 374

Partial load operation, 913

Pe energy-saving mode ID  
r5600, 687

Pe energy-saving mode pause time minimal  
p5602[0...1], 687

Pe energy-saving mode time of maximum stay  
p5606[0...1], 687

Pe energy-saving properties general  
p5611, 688

Pe energy-saving properties mode-dependent  
p5612[0...1], 688

PID autotuning monitoring time  
p2354, 649

PID autotuning offset  
p2355, 649

- PID controller, 269
- Pipe filling, 244
- Pipe filling enable
  - p29610[0...n], 749
- Pipe filling mode
  - p29611[0...n], 750
- Pipe filling monitoring time
  - p29615[0...n], 750
- Pipe filling speed
  - p29612[0...n], 750
- Pipe filling threshold
  - p29614[0...n], 750
- Pipe filling time
  - p29613[0...n], 750
- PKW (parameter, ID value), 175
- PM330 digital inputs simulation mode
  - p4095, 684
- PM330 digital inputs simulation mode setpoint
  - p4096, 684
- PM330 digital outputs status
  - r4047, 684
- PN DAP ID
  - r8939, 713
- PN Default Gateway
  - p8922[0...3], 710
- PN Default Gateway actual
  - r8932[0...3], 712
- PN device ID
  - r8909, 709
- PN DHCP Mode
  - p8924, 711
- PN DHCP Mode actual
  - r8934, 712
- PN IP address
  - p8921[0...3], 710
- PN IP address actual
  - r8931[0...3], 712
- PN MAC address
  - r8935[0...5], 713
- PN Name of Station
  - p8920[0...239], 710
- PN Name of Station actual
  - r8930[0...239], 712
- PN Subnet Mask
  - p8923[0...3], 710
- PN Subnet Mask actual
  - r8933[0...3], 712
- PollD circle center point
  - p1998[0...n], 579
- PollD technique
  - p1980[0...n], 578
- Power cable length maximum
  - r0231[0...1], 407
- Power failure, 342
- Power limit motoring
  - p1530[0...n], 554
- Power limit regenerative
  - p1531[0...n], 554
- Power unit application
  - p0205, 403
- Power unit code number
  - p0201[0...n], 401
- Power unit code number actual
  - r0200[0...n], 401
- Power unit EEPROM characteristics
  - r3930[0...4], 681
- Power unit hardware properties
  - r0204[0...n], 402
- Power unit main contactor holding time after OFF1
  - p0867, 480
- Power unit maximum current
  - r0209[0...4], 405
- Power unit monitoring time
  - p0857, 478
- Power unit motor reactor
  - p0233, 407
- Power unit overload response
  - p0290, 409
- Power unit sine-wave filter capacitance
  - p0234, 407
- Power unit temperature alarm threshold
  - p0292[0...1], 410
- Power unit thyristor rectifier wait time
  - p0868, 480
- Pressure control, 269
- Procedure, 23
- PROFIdrive diagnostics PZD send double word
  - r2063[0...15], 589
- PROFIdrive diagnostics send PZD word
  - r2053[0...16], 586
- PROFIdrive fault delay
  - p2044, 585
- PROFIdrive profile number
  - r0965, 485
- PROFIdrive PZD telegram selection
  - p0922, 482
- PROFIdrive PZD telegram selection extended
  - p2079, 590
- PROFIdrive reference speed reference frequency
  - p60000, 755
- PROFIdrive STW/ZSW interface mode
  - p2038, 584

- PROFIdrive STW1.10 = 0 mode  
p2037, 584
- PROFINET identification data  
r8859[0...7], 709
- PROFINET IP of Station  
r61001[0...3], 756
- PROFINET Name of Station  
r61000[0...239], 756
- Protection functions, 148
- Pt1000 sensor, 327
- PTC sensor, 327
- Pulse cancellation, 177
- Pulse enable, 177
- Pulse frequency, 325, 326
- Pulse frequency setpoint  
p1800[0...n], 564, 565
- Pulse suppression delay time  
p1228, 523
- Pump, 134, 141
- PZD (process data), 175
- PZD maximum interconnected  
r2067[0...1], 590
- Q**
- Questions, 934
- R**
- Ramp-down scaling 1  
p29573[0...n], 746
- Ramp-down scaling 2  
p29575[0...n], 746
- Ramp-down time, 266
- Ramp-function gen. tolerance for ramp-up and ramp-down active  
p1148[0...n], 516
- Ramp-function generator, 257
- Ramp-function generator final rounding-off time  
p1131[0...n], 511, 512
- Ramp-function generator initial rounding-off time  
p1130[0...n], 511
- Ramp-function generator minimum ramp-down time  
p1127[0...n], 511
- Ramp-function generator ramp-down time  
p1121[0...n], 510
- Ramp-function generator ramp-up time  
p1120[0...n], 509, 510
- Ramp-function generator rounding-off type  
p1134[0...n], 512
- Ramp-up scaling 1  
p29570[0...n], 745
- Ramp-up scaling 2  
p29572[0...n], 746
- Ramp-up time, 266
- Rated motor current  
p0305[0...n], 414
- Rated motor efficiency  
p0309[0...n], 416
- Rated motor frequency  
p0310[0...n], 416, 417
- Rated motor power  
p0307[0...n], 415  
r0394[0...n], 428
- Rated motor power factor  
p0308[0...n], 416  
r0332[0...n], 421
- Rated motor slip  
r0330[0...n], 420
- Rated motor speed  
p0311[0...n], 417
- Rated motor torque  
r0333[0...n], 421
- Rated motor voltage  
p0304[0...n], 414
- Rated power unit current  
r0207[0...4], 404
- Rated power unit line supply voltage  
r0208, 404
- Rated power unit power  
r0206[0...4], 403
- Ratio between the total and motor moment of inertia  
p0342[0...n], 424
- RDY (Ready), 778
- Ready for operation, 150
- Ready for switching on, 150
- Real-time clock, 292
- Reference current  
p2002, 580
- Reference power  
r2004, 581
- Reference speed reference frequency  
p2000, 579
- Reference temperature  
p2006, 582
- Reference torque  
p2003, 581
- Reference voltage  
p2001, 580
- Replace  
Control Unit, 894  
Gear unit, 894

- Hardware, 894
  - Motor, 894
  - Power Module, 894
- Reset
  - Parameter, 145
- Reset drive parameters
  - p0970, 485
- Reset energy consumption display
  - p0040, 384
- Reverse the output phase sequence
  - p1820[0...n], 567
- Reversing, 257
- Rotating measurement configuration
  - p1959[0...n], 575
  - r3928[0...n], 680
- Rotating measurement selection
  - p1960, 576
- Rounding, 266
- Rounding OFF3, 266
- RTC (Real-Time Clock), 292, 294
- RTC actual daylight saving time difference
  - r8403, 697
- RTC date
  - p8401[0...2], 696
- RTC daylight saving time setting
  - p8402[0...8], 697
- RTC DTC activation
  - p8409, 698
- RTC DTC1 off time
  - p8412[0...1], 700
- RTC DTC1 switch-on time
  - p8411[0...1], 699
- RTC DTC1 weekday of activation
  - p8410[0...6], 699
- RTC DTC2 off time
  - p8422[0...1], 701
- RTC DTC2 switch-on time
  - p8421[0...1], 701
- RTC DTC2 weekday of activation
  - p8420[0...6], 701
- RTC DTC3 off time
  - p8432[0...1], 703
- RTC DTC3 switch-on time
  - p8431[0...1], 703
- RTC DTC3 weekday of activation
  - p8430[0...6], 702
- RTC time
  - p8400[0...2], 696
- RTC weekday
  - r8404, 698

## S

- Safely remove memory card
  - p9400, 715
- Safety function, 147
- Saturation characteristic speed to determine
  - p1961, 577
- Save parameters
  - p0971, 486
- Scaling
  - Analog input, 168
  - Analog output, 173
- Scaling specific parameters referred to p0514[0]  
p0515[0...19], 434
- Scaling specific parameters referred to p0514[1]  
p0516[0...19], 434
- Scaling specific parameters referred to p0514[2]  
p0517[0...19], 434
- Scaling specific parameters referred to p0514[3]  
p0518[0...19], 434
- Scaling specific parameters referred to p0514[4]  
p0519[0...19], 435
- Scaling specific parameters referred to p0514[5]  
p0520[0...19], 435
- Scaling specific parameters referred to p0514[6]  
p0521[0...19], 435
- Scaling specific parameters referred to p0514[7]  
p0522[0...19], 436
- Scaling specific parameters referred to p0514[8]  
p0523[0...19], 436
- Scaling specific parameters referred to p0514[9]  
p0524[0...19], 436
- Scaling-specific reference values
  - p0514[0...9], 433
- SD (memory card), 760
  - Formatting, 760
- Selecting the system of units
  - p0505, 433
- Sequence control, 150
- Sequence control configuration
  - p0869, 480
- Series commissioning, 769
- Service parameter
  - p3950, 681
- Setpoint channel speed limit
  - p1063[0...n], 501
- Setpoint processing, 148, 257
- Setpoint source, 147
  - Selecting, 247, 248, 249
- Settling time, 134, 141
- Short-circuit monitoring, 327, 328



- Signal interconnection, 930
- Signal states, 778
- Skip frequency band, 257
- Skip speed 1
  - p1091[0...n], 506
- Skip speed 2
  - p1092[0...n], 506
- Skip speed 3
  - p1093[0...n], 507
- Skip speed 4
  - p1094[0...n], 507
- Skip speed bandwidth
  - p1101[0...n], 508
- Slip compensation, 296
- Slip compensation limit value
  - p1336[0...n], 543
- Slip compensation scaling
  - p1335[0...n], 542
- Slip frequency
  - r0065, 394
- Speed
  - change with BOP-2, 925
  - Limiting, 257
- Speed actual value filter time constant
  - p2153[0...n], 614
- Speed at the start of DC braking
  - p1234[0...n], 525
- Speed control, 310
- Speed control configuration
  - p1400[0...n], 545, 546
- Speed controller adaptation speed lower
  - p1464[0...n], 549
- Speed controller adaptation speed upper
  - p1465[0...n], 549
- Speed controller encoderless operation integral time
  - p1472[0...n], 550
- Speed controller encoderless operation P-gain
  - p1470[0...n], 550
- Speed controller Kp adaptation speed upper scaling
  - p1461[0...n], 548
- Speed controller speed actual value smoothing time (sensorless)
  - p1452[0...n], 548
- Speed controller Tn adaptation speed upper scaling
  - p1463[0...n], 549
- Speed setpoint selection
  - p1000[0...n], 487
- Speed setpoint smoothed
  - r0020, 378
- Speed start of hibernation mode
  - p2390[0...n], 655
- Speed threshold 1
  - p2141[0...n], 611
- Speed threshold 2
  - p2155[0...n], 614
- Speed threshold 3
  - p2161[0...n], 614
- Speed threshold 4
  - p2163[0...n], 615
- Speed\_ctrl\_opt dynamic factor
  - p1967, 578
- Speed\_ctrl\_opt dynamic factor actual
  - r1968, 578
- Speed\_ctrl\_opt speed
  - p1965, 577
- Square-law characteristic, 298, 307
- Standards
  - EN 61800-3, 29
- Star connection (Y), 93
- Starting behavior
  - Optimization, 308
- Starting behavior"; "Optimization, 301
- Starting current, 306
- Starting current (voltage boost) permanent
  - p1310[0...n], 539
- Starting current (voltage boost) when accelerating
  - p1311[0...n], 540
- Starting current (voltage boost) when starting
  - p1312[0...n], 540
- State overview, 150
- Stator resistance reference
  - p0629[0...n], 448
- Status word
  - Status word 1, 177, 178
  - Status word 3, 180
- STO (Safe Torque Off), 219
  - select, 219
- Stop Category 0, 220
- Storage medium, 759
- STW1 (control word 1), 177
- Subindex, 184
- Support, 934
- Switch off
  - Motor, 151
  - OFF1 command, 151
  - OFF2 command, 151
  - OFF3 command, 151
- Switch on
  - Motor, 151
  - ON command, 151
- Switching on inhibited, 150, 177
- Switching-on a motor with BOP-2, 925

Switch-on delay  $n_{act} = n_{set}$   
p2167[0...n], 616  
Symbols, 23  
System runtime, 780  
System runtime relative  
p0969, 485  
System runtime total  
r2114[0...1], 603

## T

Techn. controller threshold value f. I comp. hold for skip speed  
p2339, 646  
Technological application (Dynamic Drive Control)  
p0502, 431, 432  
Technological application (Standard Drive Control)  
p0501, 431  
Technological unit reference quantity  
p0596, 439  
Technological unit selection  
p0595, 438  
Technology application  
p0500, 429, 430  
Technology controller, 179, 217, 269  
Technology controller actual value filter time constant  
p2265, 637  
Technology controller actual value function  
p2270, 638  
Technology controller actual value inversion (sensor type)  
p2271, 638  
Technology controller configuration  
p2252, 634  
Technology controller differentiation time constant  
p2274, 639  
Technology controller fault response  
p2345, 647  
Technology controller fixed value selection method  
p2216[0...n], 629  
Technology controller gain actual value  
p2269, 637  
Technology controller integral time  
p2285, 639  
Technology controller Kp adaptation lower starting point  
p2313, 644  
Technology controller Kp adaptation lower value  
p2311, 643  
Technology controller Kp adaptation upper starting point  
p2314, 644  
Technology controller Kp adaptation upper value  
p2312, 644  
Technology controller lower limit actual value  
p2268, 637  
Technology controller mode  
p2251, 633  
Technology controller motorized potentiometer configuration  
p2230[0...n], 630  
Technology controller motorized potentiometer maximum value  
p2237[0...n], 632  
Technology controller motorized potentiometer minimum value  
p2238[0...n], 632  
Technology controller motorized potentiometer ramp-down time  
p2248[0...n], 633  
Technology controller motorized potentiometer ramp-up time  
p2247[0...n], 633  
Technology controller motorized potentiometer setpoint memory  
r2231, 631  
Technology controller motorized potentiometer starting value  
p2240[0...n], 632  
Technology controller number actual  
r2229, 630  
Technology controller output signal starting value  
p2302, 642  
Technology controller proportional gain  
p2280, 639  
Technology controller ramp-down time  
p2258, 635  
Technology controller ramp-up time  
p2257, 635  
Technology controller ramp-up/ramp-down time  
p2293, 641  
Technology controller setpoint 1 scaling  
p2255, 635  
Technology controller setpoint 2 scaling  
p2256, 635  
Technology controller setpoint filter time constant  
p2261, 636  
Technology controller system deviation inversion  
p2306, 643  
Technology controller Tn adaptation lower starting point  
p2320, 646  
Technology controller Tn adaptation lower value  
p2318, 645

Technology controller Tn adaptation upper starting point  
 p2321, 646

Technology controller Tn adaptation upper value  
 p2319, 645

Technology controller type  
 p2263, 636

Technology controller upper limit actual value  
 p2267, 637

Temperature calculation, 329

Temperature monitoring, 326, 329

Temperature sensor, 99

Temperature switch, 327

Terminal block, 153

Terminal strip, 118  
 Factory setting, 99

Test pulse evaluation configuration  
 p1901, 570, 571

Thermal resistance adaptation reduction factor  
 p0614[0...n], 444

Threshold for zero speed detection  
 p1226[0...n], 522

Threshold speed 2  
 p29571[0...n], 746

Threshold speed 3  
 p29574[0...n], 746

Time, 292

Time control, 294

Time switch, 294

Torque accuracy, 134, 141

Torque actual value filter time constant  
 p3233[0...n], 666

Torque setpoint static (sensorless)  
 p1610[0...n], 560

## U

U/f control configuration  
 p1302[0...n], 538

U/f control FCC starting frequency  
 p1333[0...n], 541

U/f control slip compensation starting frequency  
 p1334[0...n], 541

U/f mode resonance damping gain  
 p1338[0...n], 543

U/f mode resonance damping maximum frequency  
 p1349[0...n], 545

Unit system, 216

Update  
 Firmware, 894

Upgrading the firmware, 889

Upload, 760  
 Download, 766

USB memory access  
 p8991, 715

Use for the intended purpose, 24

User interfaces, 94

UTC (Universal Time Coordinated), 292

## V

V/f characteristic, 296

Vdc controller configuration  
 p1281[0...n], 533

Vdc controller configuration (U/f)  
 p1280[0...n], 533

Vdc controller configuration (vector control)  
 p1240[0...n], 525

Vdc controller integral time  
 p1251[0...n], 528

Vdc controller integral time (U/f)  
 p1291[0...n], 536

Vdc controller proportional gain  
 p1250[0...n], 528

Vdc controller proportional gain (U/f)  
 p1290[0...n], 535

Vdc controller rate time  
 p1252[0...n], 528

Vdc controller rate time (U/f)  
 p1292[0...n], 536

Vdc\_max controller automatic detection ON signal level (U/f)  
 p1294, 536

Vdc\_max controller automatic ON level detection  
 p1254, 528

Vdc\_max controller dynamic factor  
 p1243[0...n], 526

Vdc\_max controller dynamic factor (U/f)  
 p1283[0...n], 534

Vdc\_max controller speed threshold  
 p1249[0...n], 527

Vdc\_max controller switch-in level  
 r1242, 526

Vdc\_max controller switch-in level (U/f)  
 r1282, 534

Vdc\_max controller time threshold (U/f)  
 p1284[0...n], 534

Vdc\_min controller, 345

Vdc\_min controller dynamic factor (kinetic buffering)  
 p1247[0...n], 527

Vdc\_min controller dynamic factor (kinetic buffering) (U/f)  
 p1287[0...n], 535

Vdc\_min controller response (kinetic buffering)  
p1256[0...n], 529

Vdc\_min controller response (kinetic buffering) (U/f)  
p1296[0...n], 536

Vdc\_min controller speed threshold  
p1257[0...n], 529

Vdc\_min controller speed threshold (U/f)  
p1297[0...n], 537

Vdc\_min controller switch-in level (kinetic buffering)  
p1245[0...n], 527  
r1246, 527

Vdc\_min controller switch-in level (kinetic buffering)  
(U/f)  
p1285[0...n], 535  
r1286, 535

Vdc\_min controller time threshold  
p1255[0...n], 528

Vdc\_min controller time threshold (U/f)  
p1295[0...n], 536

Vector control, 316  
Sensorless, 310

Voltage boost, 296, 301, 306, 308

Voltage boost total  
r1315, 541

Voltage input, 165

Voltage limiting  
p1331[0...n], 541

Voltage measurement configuring  
p0247, 408

Voltage reserve dynamic  
p1574[0...n], 557

## W

Wire-break monitoring, 169, 327, 328

Write protection, 770  
p7761, 690

Write protection multi-master fieldbus system access  
behavior  
p7762, 691

## Z

Zero speed detection monitoring time  
p1227, 522

Ziegler Nichols, 282

ZSW 1 (status word 1)", 178

ZSW1 (status word 1), 177

ZWS3 (status word 3), 180



## Further information

SINAMICS converters:

[www.siemens.com/sinamics](http://www.siemens.com/sinamics)

Safety Integrated

[www.siemens.com/safety-integrated](http://www.siemens.com/safety-integrated)

PROFINET

[www.siemens.com/profinet](http://www.siemens.com/profinet)

Siemens AG  
Digital Factory  
Motion Control  
Postfach 3180  
91050 ERLANGEN  
Germany

Scan the QR code for  
additional  
information about  
SINAMICS G120.

