



Operation **Manual**

BPJ1 Series **Mining Explosion-proof and** **Intrinsic Safety AC Inverter**





Content

Content.....	1
1 Safety precautions.....	2
1.1 Warning symbols.....	2
1.2 Installation and maintenance.....	2
2 Product overview.....	4
2.1 Product introduction.....	4
2.2 Environment conditions.....	4
2.3 Application.....	4
2.4 Explosion-proof type.....	4
2.5 Design standards.....	4
2.6 Type designation key and selection.....	5
3 Technical features.....	6
3.1 Main features.....	6
3.2 Main parameters.....	6
3.3 Intrinsically safe terminals.....	7
4 Dimension and weight.....	9
5 Structure features.....	10
6 Keypad.....	12
6.1 Matrix keypad.....	12
6.2 Function instruction of buttons.....	12
6.3 Operation procedure and parameter setting.....	13
7 Typical electrical diagram.....	14
7.1 BPJ1 two-quadrant explosion-proof inverter.....	14
7.2 BPJ1 four-quadrant explosion-proof inverter.....	15
8 Wiring diagram.....	16
8.1 Wiring diagram of two-quadrant inverter.....	16
8.2 Wiring diagram of four-quadrant inverter.....	21

1 Safety precautions

1.1 Warning symbols

Please read this manual carefully before installing, operating, maintaining or inspecting the inverter. The safety precautions are classified into cautions and notes. Cautions refer to the conditions which may result in injury or death and damage to the devices, and advice on how to avoid the danger, while notes are mainly used for the instructions of special points. The following is three levels of cautions.

Symbols	Name	Instruction
	Danger	Dangerous voltage which may cause physical injury or damage to the devices
	Warning	Except dangerous voltage, other cases which may cause physical injury or damage to the devices
	Electrostatic discharge	Electrostatic discharge which may cause damage to the devices

1.2 Installation and maintenance

	<ul style="list-style-type: none"> ✧ Do not carry out any operation on the inverter, motor and motor cable when the power supply is applied. ✧ Only qualified electricians are allowed to install and maintain the inverter. ✧ Do not operate until waiting for 15 minutes after power off and ensure the bus capacitor inside the inverter completes discharge when the inverter, motor and motor cable need maintenance. ✧ Do not touch the live control part of the inverter or the live external circuit connected to the control part because the control circuit may cause dangerous voltage inside the inverter even at power loss. ✧ Do not carry out any isolation or withstand voltage test at inverter side directly. ✧ Ensure whether the phase sequence of the motor cable is correct when the motor needs to be connected again. ✧ As long as the inverter powers on, dangerous voltage will be present at the terminal of the motor cable regardless of whether the motor runs. ✧ Dangerous high voltage may exist on P+ and P- terminals of DC bus. ✧ Dangerous voltage may exist on the relay output terminals and the specific degree is decided by the external circuit.
---	--

	<ul style="list-style-type: none"> ◇ The PCB board has electrostatic sensitive devices. Before removing it, please wear a wrist strap; if not necessary, do not touch the board.
---	---

Grounding:

	<ul style="list-style-type: none"> ◇ Ensure the inverter, motor and relevant devices are well-grounded to guarantee personal safety in any circumstances and reduce electromagnetic radiation effectively. ◇ Ensure the grounding wire diameter complies with safety standards. ◇ Ensure each cabinet is grounded independently in multi-cabinet connection. ◇ Select the shield cable to reduce electromagnetic radiation, adopt 360° high-frequency link, and connect the shield cable with PE directly to meet the requirements of safety. ◇ Only when the cross section of the shield cable meets the safety standards can it be used as the grounding wire. ◇ If the inverter has any leakage during working, select independent grounding to ensure personal safety.
---	--

Mechanical installation:

	<ul style="list-style-type: none"> ◇ Do not move the inverter alone because it is quite heavy and avoid the cover downward. ◇ Ensure there is enough space left for heat elimination after installation. ◇ Do not fix the inverter by riveting or soldering.
---	---

Running:

	<ul style="list-style-type: none"> ◇ Before starting the inverter, ensure the motor and peripheral devices in connection meet the requirement of inverter running speed. After adjusted by the inverter, the motor can run above or below the speed range of power frequency. ◇ In case of emergency, prevent starting automatic fault reset; otherwise, the faulty inverter will reset automatically and continue running. ◇ The allowable maximum number of charge for the DC bus of the inverter (direct electrifying for the inverter) is 5 per 10 minutes.
---	--

2 Product overview

2.1 Product introduction

BPJ1 series mining explosion-proof and intrinsic safety AC inverters (shorted as inverter below) mainly used in underground mines in the circumstances of methane, coal dust and no corrosive gas achieve soft start/stop, FWD/REV rotation and speed control over 3-phase asynchronous motors/synchronous motors at AC 50Hz and rated voltage 660V or 1140V, and protect the motors and relative circuits. BPJ1 series inverters provide three control modes: vector control (VC), sensorless vector control (SVC) and V/F control.

2.2 Environment conditions

- Air pressure: 86kPa~106kPa;
- Temperature of running environment: -5°C~+40°C;
- Max. relative humidity≤95% (+25°C), no condensation;
- No obvious vibration or impact;
- Explosive atmospheres with methane, coal dust but no gas or steam which causes metal corrosion or insulation breakdown.

2.3 Application

Special mining devices, including belt conveyors, emulsion pumps, fans, winches, water pumps, scraper conveyors and coal mining machine

2.4 Explosion-proof type

Mining explosion-proof and intrinsic safety, mark: Exd[ib]I Mb

2.5 Design standards

Regulations for Coal Mine Safety

Code for Power Design of Mine

Safety Inspection Code of Winder for Coal Mine

GB/T 191-2008	Package storage and transportation graphic mark
GB/T 2423.4-2008	Environment test for electric and electronic products-Part 2: Test method: Db: Damp heat, cyclic (12+12h cycle)
GB 3836.1-2010	Explosive atmospheres-Part 1: Equipment: General requirements
GB 3836.2-2010	Explosive atmospheres-Part 2: Equipment protection by flameproof enclosure “d”
GB 3836.4-2010	Explosive atmospheres-Part 4: Equipment protection by intrinsic safety “i”
GB 12668.3-2003	Adjustable speed electrical power drive systems-Part 3: EMC product standard including specific test methods
GB/T 14549-1993	Quality of electric energy supply Harmonics in public supply network

GB 14048.1-2006	Low-voltage switchgear and controlgear-Part 1: General rules
MT 1099-2009	Frequency conversion equipment for coal mine
MT/T 154.2-1996	Model designation method and management approach of electric appliances for coal mine
MT/T 412-1995	Low-voltage terminals of explosion-proof electrical apparatus
MT/T 661-2011	General technical conditions for electrical apparatus used underground mine
AQ 1043-2007	Mining products safety label

2.6 Type designation key and selection

2.6.1 Type designation key

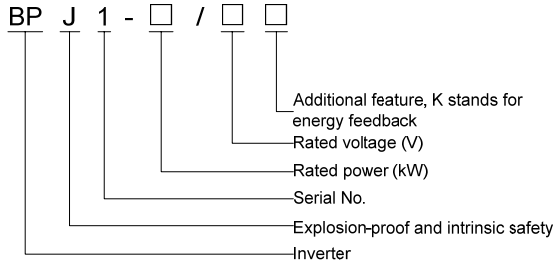

2.6.2 Product selection

Model		Rated power (kW)	Input current (A)	Rated output current (A)
660V two-quadrant	BPJ1-55/660	55	65	63
	BPJ1-90/660	90	95	98
	BPJ1-185/660	185	190	198
	BPJ1-280/660	280	290	320
	BPJ1-400/660	400	411	430
1140V two-quadrant	BPJ1-90/1140	90	57	58
	BPJ1-250/1140	250	158	162
	BPJ1-315/1140	315	200	208
	BPJ1-400/1140	400	260	260
	BPJ1-500/1140	500	325	325
	BPJ1-630/1140	630	400	400
660V four-quadrant	BPJ1-185/660K	185	170	198
	BPJ1-250/660K	250	230	270
	BPJ1-315/660K	315	290	350
1140V four-quadrant	BPJ1-250/1140K	250	133	162
	BPJ1-400/1140K	400	213	260

3 Technical features

BPJ1 mining explosion-proof inverter is applicable to underground mines in bad conditions and it can adopt either local or remote control manner. Under the control of the inverter, AC asynchronous motors and permanent magnet synchronous motors can realize soft start, VVVF, improvement of rotating accuracy, change of power factor and protection of overcurrent, overvoltage and overload. The inverter is fitted with LCD keypad for running parameters display.

Due to large starting torque and stable start-up, AC asynchronous motors and permanent magnet synchronous motors can achieve smooth start-up, speed regulation and stop at any loads, reducing mechanical and electrical impact and prolonging service life. Master-slave control can be applied to belt conveyors for power balance in multi-motor drive.

When the inverter is applied to emulsion pumps, under PID control, the hydraulic system can obtain constant pressure, cut down on power consumption and reduce impact on pipes.

3.1 Main features

1. Grid voltage: 660V±15%, 1140V±10%;
2. Brand-new dual-CUP (DSP+MCU) hardware control improving control performance greatly;
3. Three control modes: Vector control (VC), sensorless vector control (SVC) and V/F control;
4. Master-slave control for synchronous torque or speed and power balance among motors;
5. Soft start and stop for heavy loads with low starting current, stable starting speed and small impact on the grid;
6. Rich communication control functions, Modbus, Profibus-DP and Ethernet communication modes, communication protocols conforming to the international standards, compatible with the requirements of various control systems;
7. Overvoltage, overcurrent, overload, phase loss, short circuit and overheat protection;
8. Excellent electromagnetic compatibility.

3.2 Main parameters

Model	660V series	1140V series
Input voltage	660V±15%	1140V±10%
Input frequency	47~63Hz	
Output frequency	0~50Hz	
Explosion-proof type	Explosion-proof and intrinsic safety	
Mark	Exd[ib]	
Running	Temperature: 0°C~40°C; humidity: 5%~95%; gas and dust	

Model	660V series	1140V series
environment	explosive atmospheres	
Control mode	Vector control (VC), sensorless vector control (SVC) and V/F control	
Display	LED display	
Running	Continuous	
Heat elimination	Heat pipe conduction by natural or air cooling	
Control manner	Local or remote control	
Max. intrinsically safe open-loop voltage	25V	
Intrinsically safe parameters	U0: 25VDC I0: 160mA	

3.3 Intrinsically safe terminals

Type	Code	Name	Function instruction
Power supply	10V	10V reference power supply	Provide 10V reference power supply for the external with the maximum output current 20mA Serve as the power supply of external potentiometer above 5kΩ resistance
	-10V	-10V reference power supply	Provide -10V reference power supply for the external with the maximum output current 10mA Serve as the power supply of external potentiometer above 5kΩ resistance
	24V	24V power supply	Max. output voltage:25V, Max. output current:160mA Serve as the power supply of digital input and output or external sensor
Common terminal	COM	Common terminal	Common terminal of +24V or external power supply
	GND	Grounding terminal	±10V reference null potential (Note: GND and COM are isolated.)
Analog input	AI1	Analog input 1	1. Input range: 0~10V or 0~20mA 2. Input impedance: voltage input: 20kΩ, current input: 500Ω 3. Voltage or current input depends on jumper J3

Type	Code	Name	Function instruction
	AI2	Analog input 2	<ol style="list-style-type: none"> 1. Input range: 0~10V or 0~20mA 2. Input impedance: voltage input: 20kΩ, current input: 500Ω 3. Voltage or current input depends on jumper J4
Analog output	AO1	Analog output 1	<ol style="list-style-type: none"> 1. Output range: -10~10V or -20~20mA 2. Voltage or current output depends on jumper J1
	AO2	Analog output 2	<ol style="list-style-type: none"> 1. Output range: -10~10V or -20~20mA 2. Voltage or current output depends on jumper J2
Digital input	S1	Switch input 1	Switch input terminals: <ol style="list-style-type: none"> 1. Internal impedance: 3.3kΩ 2. 12~30V voltage input is available
	S2	Switch input 2	
	S3	Switch input 3	
	S4	Switch input 4	
	S5	Switch input 5	
	S6	Switch input 6	
	S7	Switch input 7	
	S8	Switch input 8	

4 Dimension and weight

Model		Dimension mm (W*D*H)		Weight (kg)
660V two-quadrant	BPJ1-55/660	815*1025*910		1100
	BPJ1-90/660	1705*1135*1075		1300
	BPJ1-185/660	1670*1260*1270		1700
	BPJ1-280/660	2245*1345*1210		2500
	BPJ1-400/660	2245*1345*1210		2600
1140V two-quadrant	BPJ1-90/1140	1705*1135*1075		1250
	BPJ1-250/1140	1670*1260*1270		1800
	BPJ1-315/1140	2245*1345*1210		2300
	BPJ1-400/1140	2245*1345*1210		2500
	BPJ1-500/1140	2245*1345*1210		2600
	BPJ1-630/1140	2705*1105*1355		2800
660V four-quadrant	BPJ1-185/660K	Main cabinet	1875*1300*1375	1700
		Auxiliary cabinet	1665*1265*1270	1150
	BPJ1-250/660K	Main cabinet	1875*1300*1375	2000
		Auxiliary cabinet	1665*1265*1270	1350
	BPJ1-315/660K	Main cabinet	1875*1300*1375	1400
		Auxiliary cabinet	1665*1265*1270	2050
1140V four-quadrant	BPJ1-250/1140K	Main cabinet	1875*1300*1375	2000
		Auxiliary cabinet	1665*1265*1270	1350
	BPJ1-400/1140K	Main cabinet	2670*1320*1375	2500
		Auxiliary cabinet	1665*1265*1270	1400

5 Structure features

In a shape of a straight cuboid, the inverter consists of three cabinets from left to right and two distribution cabinets on the upper left and right. The input filter cabinet on the left has disconnecter, input filter and input reactor; the middle cabinet has rectifier unit, converter unit and control circuit; the output filter cabinet on the right has output filter and output reactor; the input distribution cabinet on the upper left has input terminal and additional 9-core terminal connector; the output distribution cabinet on the upper right has output terminal and additional 9-core terminal connector.

The following figures are the left-front view and left-rear view:

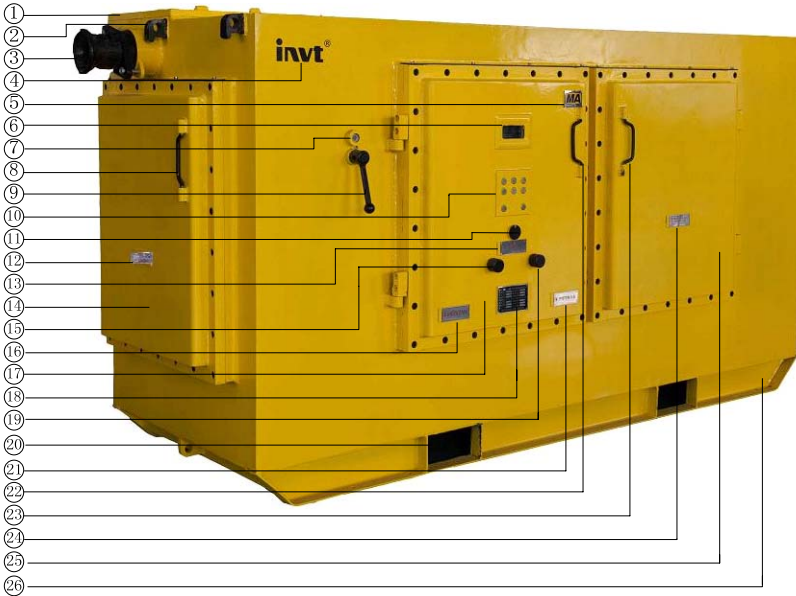

Left-front view

No.	Name	No.	Name	No.	Name
1	Cover of input distribution cabinet	2	Hoist ring	3	Interface of power input line
4	Company logo	5	MA mark	6	LED/LCD display
7	Emergency stop button	8	Handle of left side door	9	Handle of disconnecter
10	Matrix keypad	11	Emergency button	12	Sign of fasteners degree
13	Sign of discharge	14	Left side door	15	Emergency button

	button				
16	Explosion-proof mark	17	Left front door	18	BPJ1 name plate
19	Emergency button	20	Forklift hole	21	Warning sign
22	Handle of left front door	23	Handle of right front door	24	Warning sign
25	Right front door	26	Chassis		











Left-rear view









No.	Name	No.	Name	No.	Name
1	Hoist ring	2	Interface of control line	3	Sign of fasteners degree
4	Radiator guard	5	Cooling fan	6	

6 Keypad

6.1 Matrix keypad

6.2 Function instruction of buttons

Buttons	Name	Function instruction
	Programming key	Enter or escape from the first level menu and remove the parameter quickly.
	Entry key	Enter the menu step by step and confirm parameters.
	UP key	Increase data or function code progressively.
	DOWN key	Decrease data or function code progressively.
	Right-shift key	Move right to select the displaying parameter circularly in stopping and running mode. Select the digit during parameter modification.
	Run key	The key is used to operate the inverter in keypad operation mode.
	Stop/Reset key	The key is used to stop in running state and it is limited by function code P07.04. The key is used to reset all control modes in fault alarm state.
	Quick key	The key is confirmed by function code P07.03. 0: Jogging running (only apply to keypad control) 1: Shift between FWD and REV rotation (only apply to keypad control)
	Combination	The inverter will coast to stop when both RUN and STOP/RST are pressed at the same time.

6.3 Operation procedure and parameter setting

The inverter has three-level menu:

1. Group number of function code (first level menu)
2. Tab of function code (second level menu)
3. Set value of function code (third level menu)

Remarks: Press **PRG/ESC** or **DATA/ENT** to return to the second level menu from the third level menu. The difference: pressing **DATA/ENT** will save the set parameters into the control board and then return to the second level menu with shifting to the next function code automatically while pressing **PRG/ESC** will directly return to the second level menu without saving the parameters and keep staying at the current function code.

Example: Set function code P1.01 from 0.0% to 1.0%.

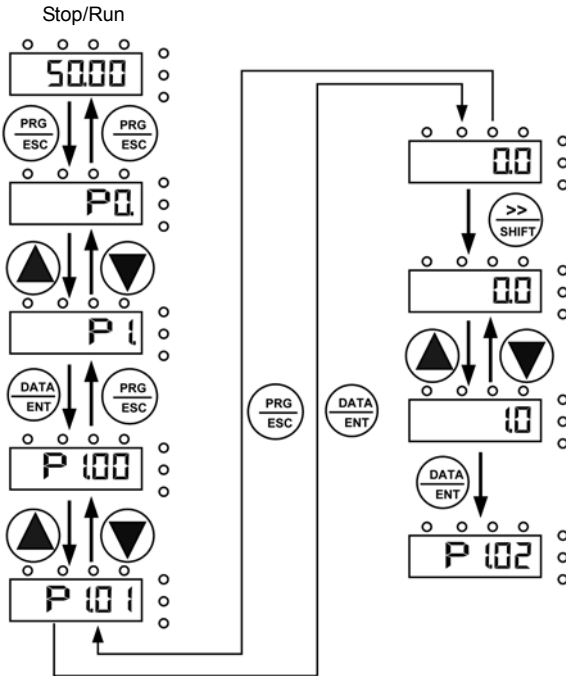

Fig 3-3 Sketch map of three-level menu

Under the third level menu, if the parameter has no flicker bit, it means the function code cannot be modified. The possible reasons could be:

- 1) This function code is unmodifiable parameter, such as actual detected parameter and operation records;
- 2) This function code is unmodifiable in run state but modifiable in stop state.

7 Typical electrical diagram

7.1 BPJ1 two-quadrant explosion-proof inverter

The two-quadrant inverter adopts rectifier bridge to convert AC into DC and then the IGBT technology to convert DC into AC of variable voltage and frequency to control AC motors. The inverter can be only applied in electromotion state, so it is called two-quadrant inverter.

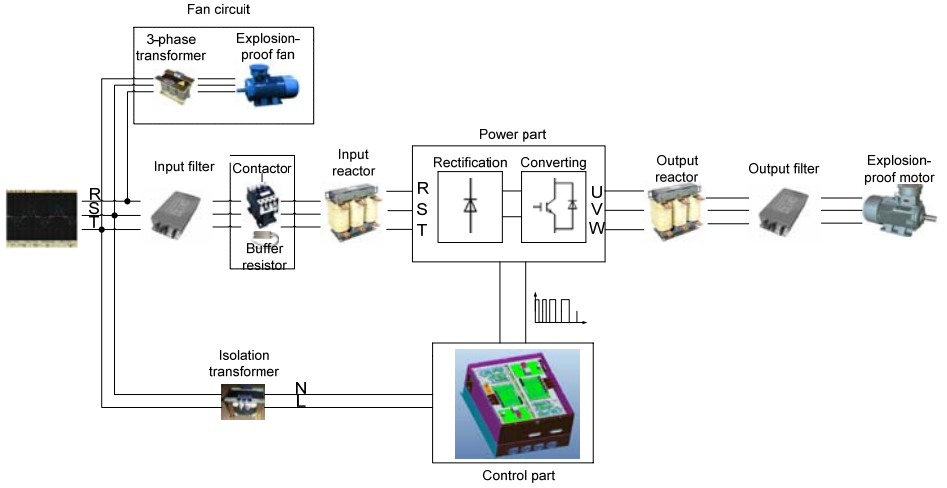

7.2 BPJ1 four-quadrant explosion-proof inverter

IGBT power module can realize bidirectional energy flow. If IGBT works as rectifier bridge and DSP featuring high speed and strong computing power generates PWM pulse, for one thing, the power factor can be adjusted to eliminate harmonic pollution on the grid and change the inverters into green products; for another, the energy generated by motors can be fed back to the grid to save energy.

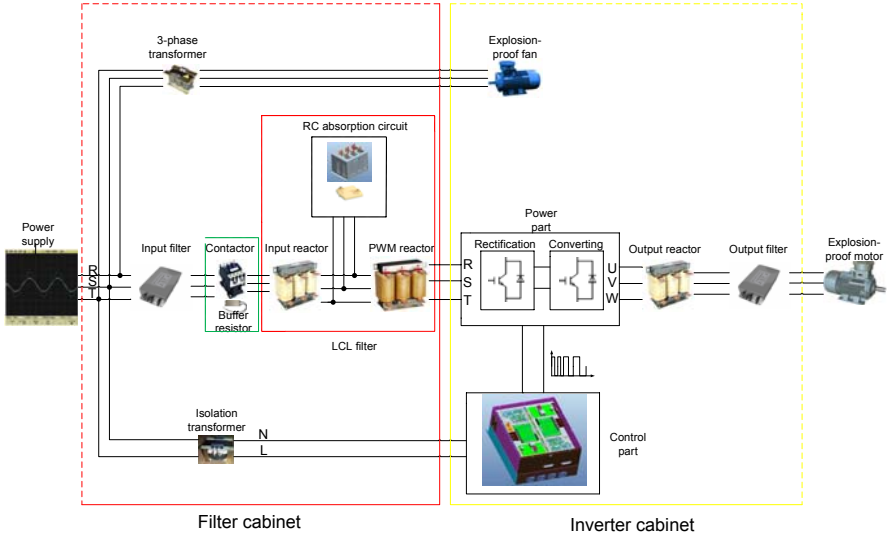

8 Wiring diagram

8.1 Wiring diagram of two-quadrant inverter

8.1.1 Wiring diagram of BPJ1-55/660

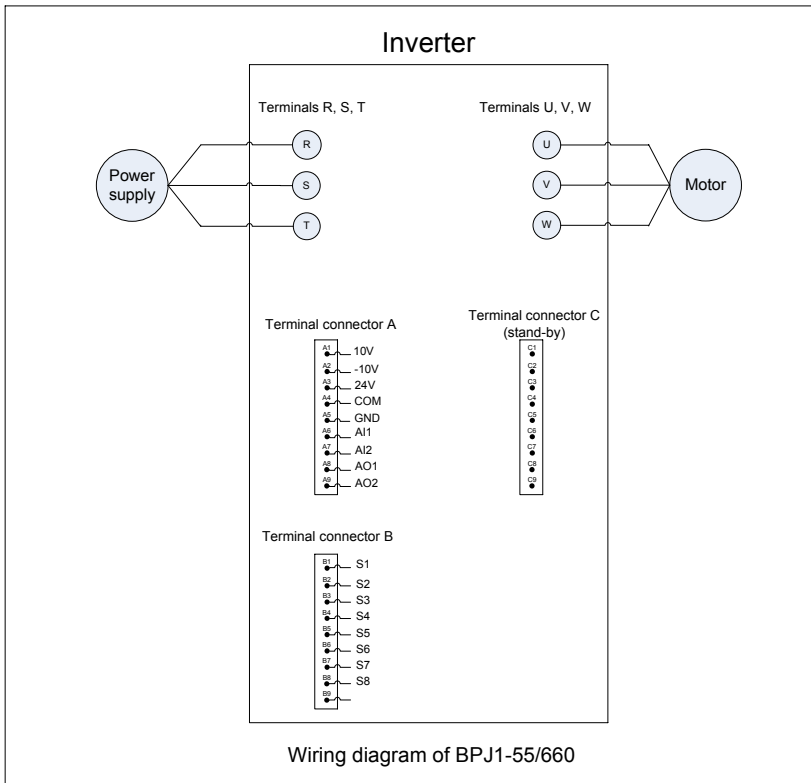

8.1.2 Wiring diagram of BPJ1-90/660 and BPJ1-90/1140

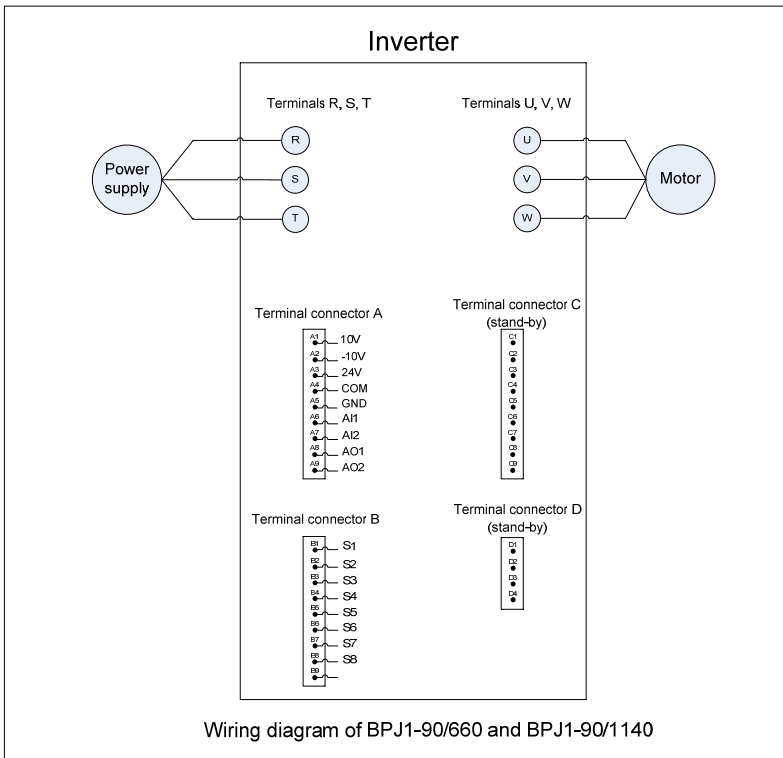

8.1.3 Wiring diagram of BPJ1-185/660 and BPJ1-250/1140

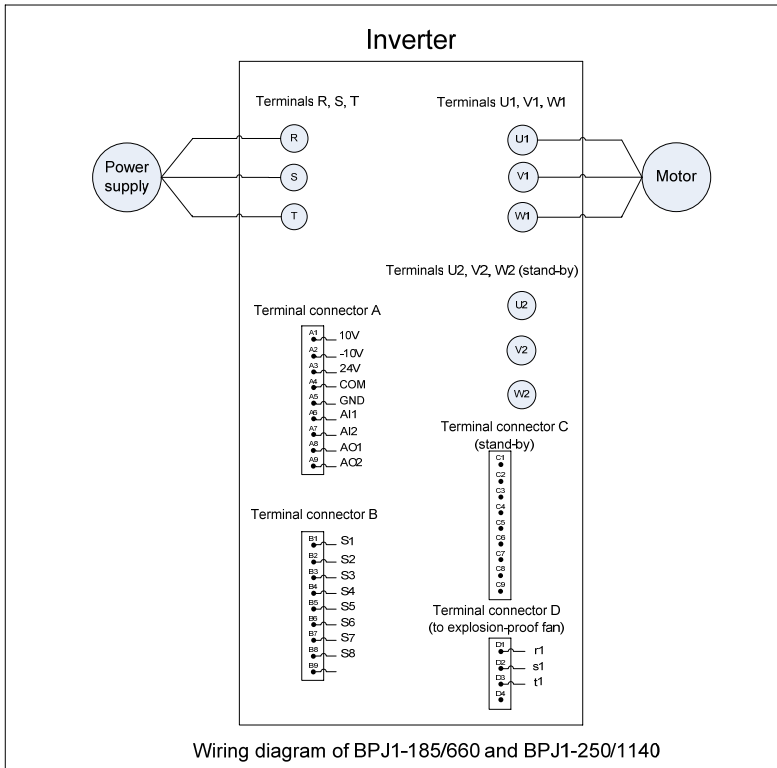

8.1.4 Wiring diagram of BPJ1-280/660, BPJ1-400/660, BPJ1-315/1140, BPJ1-400/1140 and BPJ1-500/1140

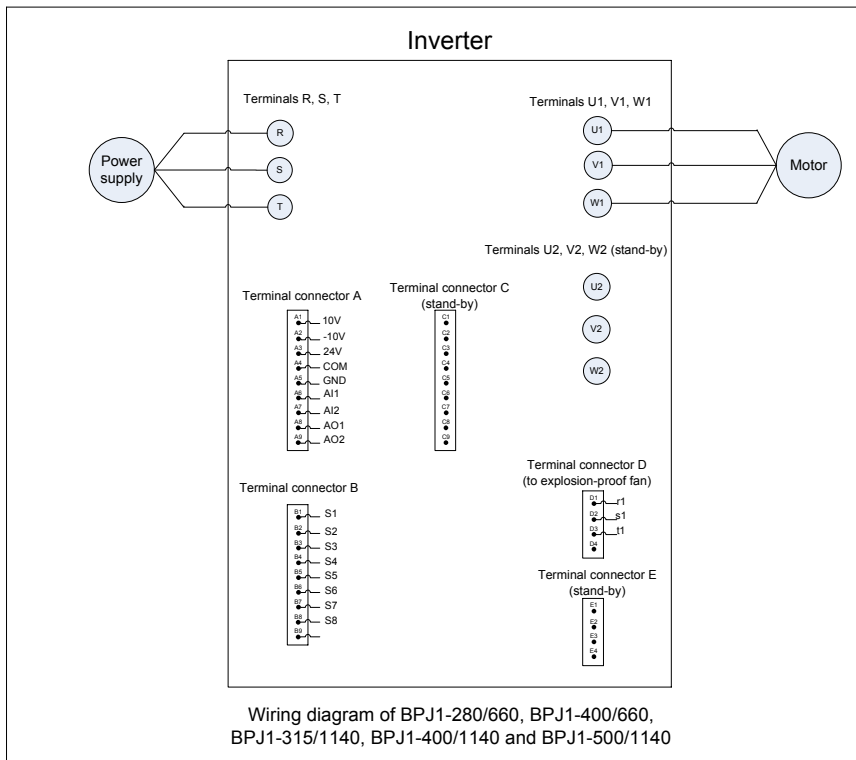

8.1.5 Wiring diagram of BPJ1-630/1140

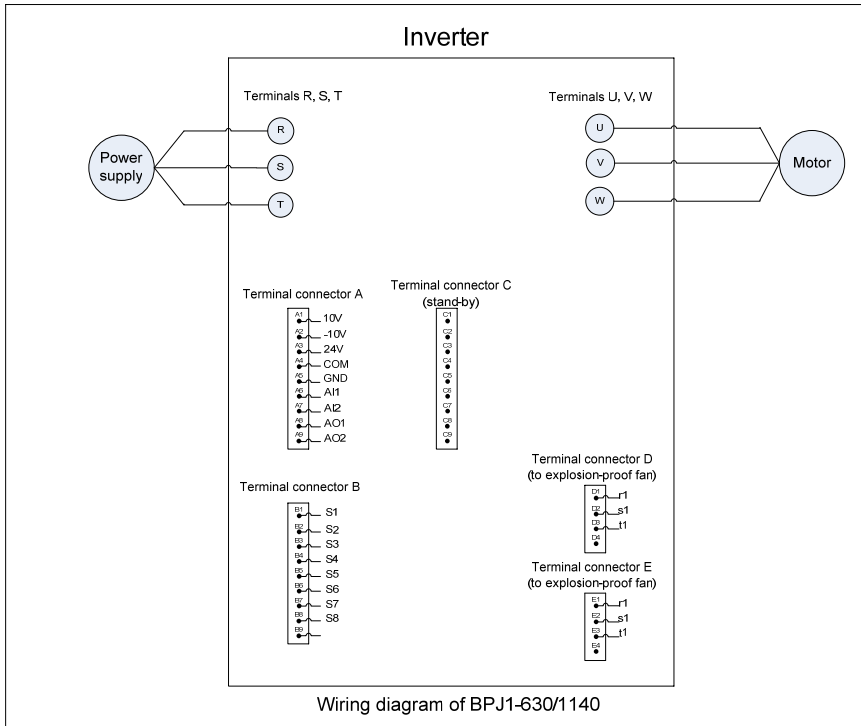

8.2 Wiring diagram of four-quadrant inverter

8.2.1 Wiring diagram of BPJ1-185/660K, BPJ1-250/660K and BPJ1-315/660K

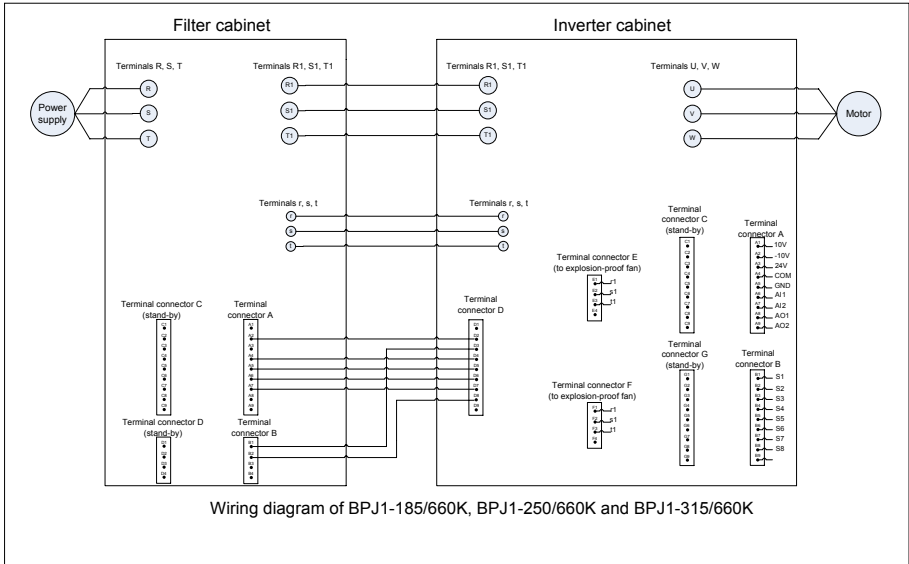

8.2.2 Wiring diagram of BPJ1-250/1140K

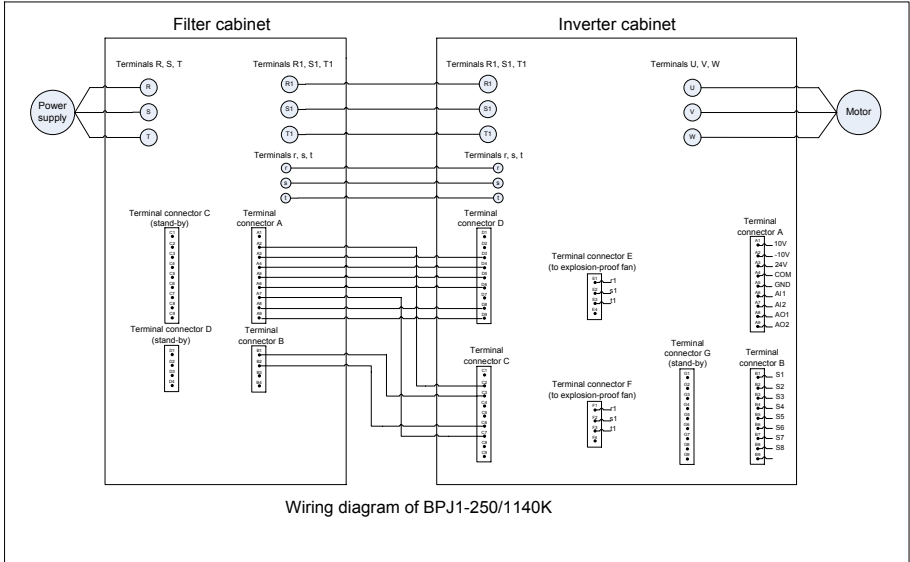

8.2.3 Wiring diagram of BPJ1-400/1140K

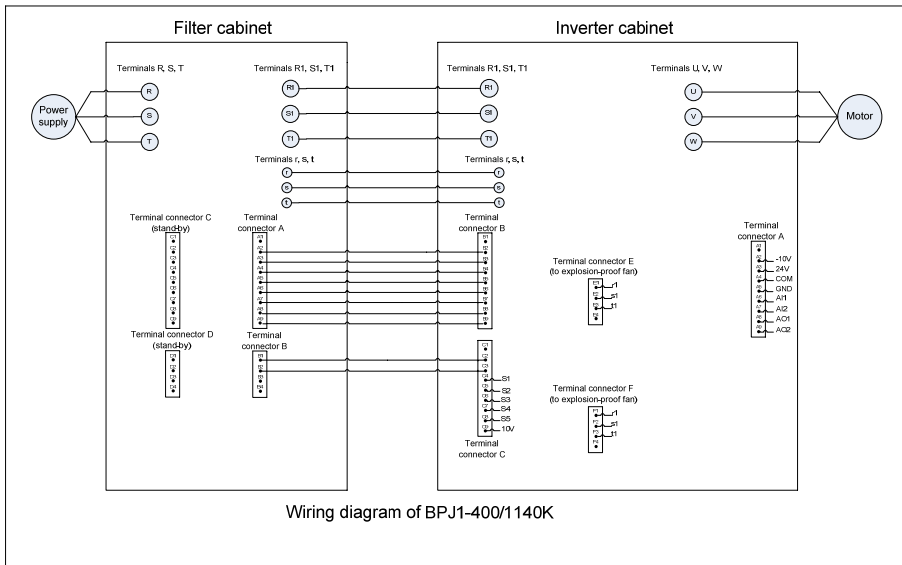

- Remarks: 1. 4-core terminals: Rated running current≤16A, voltage degree 660V;
 2. 9-core terminals: Rated running current≤10A, voltage degree 200V.



Service line:0512-6691 6509 Website:www.invt-equipment.com

No.189 Kunlun Shan Road, Science&Technology Town,New District,Suzhou,Jiangsu,China

Electric Drive: ■ Explosion-proof Inverter

Information may be subject to change without notice during product improving.

201306(V1.0)